

# An Analog Linearizer Using Second Harmonic Signals Feedforwarding

Sung Yong Kim<sup>1</sup>, Mi Ae Jang<sup>1</sup>, Ki Kyung Jeon<sup>1</sup>, Young Kim<sup>1</sup>, and Yong Chae Jeong<sup>2</sup>

<sup>1</sup>School of Electronics Engineering, Kumoh National Institute of Technology, 1, Yangho-dong, Gumi, Gyungbuk, Korea,

<sup>2</sup>Division of Electronic & Information Engineering, Chonbuk National University, Chonju, Korea

Email : [youngk@kumoh.ac.kr](mailto:youngk@kumoh.ac.kr)

**Abstract** - In this paper, an analog linearizer using second harmonic signals feedforwarding is proposed. The harmonic generator of the proposed linearizer that consists of a small signal amplifier extracts second harmonic signals. A vector modulator, modulate fundamental signal with second harmonic signals, makes the inverse third order intermodulation distortion (IMD3) signals of power amplifier and controls amplitude/phase of them with modulation factors. As a result, this linearizer is suppressed IMD3 signals of power amplifier effectively. The test results show that IMD3 signals of power amplifier are suppressed more than 20dB for CW two-tone signals. Also, it's improved the adjacent channel power ratio (ACPR) more than 7dB for CDMA (IS-95) signals.

## I. INTRODUCTION

The signals that use linear modulation schemes, however, such as QPSK, QAM, have a high peak-to-average power ratio and the signal envelope is changed severely. Therefore, intermodulation distortion is generated by RF power amplifier nonlinearity. Especially the third order intermodulation distortion (IMD3) signals are regarded as troublesome in communication system. This phenomenon gives rise to interfering signals in adjacent channel. Recent RF and microwave amplifiers shall have an excellent linearity performance. This parameter is specified in terms of the carrier to intermodulation distortion ratio (C/I) or the adjacent channel power ratio (ACPR). Many linearization techniques have been proposed to reduce intermodulation distortion [1]-[5].

In this paper, an analog linearizer using second harmonic signals feedforwarding is proposed. This linearizer of Cartesian form is created the inverse IMD3 signals of power amplifier by amplitude modulation of

second harmonic signals. The second harmonic signals are extracted the harmonic generator that consists of small signal amplifier with abnormal bias and then AM modulator is modulated original signal with extracted IM signals. Vector modulator is combined with in-phase (I) and quadrature-phase (Q) modulation signal. It's a generated IM signals. Then the generated modulation signals are controlled amplitude and phase by variable gain amplifier. This paper is presented block diagram and operation principle of proposed linearizer. And the experiment results show that is obtained by applying proposed linearizer to power amplifier.

## II. OPERATION OF THE CIRCUIT

We assume that the amplifier nonlinearity can be expressed in terms of a power series [6] like eq. (1).

$$v_o = k_1 v_i + k_2 v_i^2 + k_3 v_i^3 + k_4 v_i^4 + \dots \quad (1)$$

where  $v_i$  is input and  $v_o$  is output signal.

If the input signal consists of two-tone, equal amplitude, given by the expression

$$v_i = A[\cos(\omega_1 t) + \cos(\omega_2 t)] \quad (2)$$

Unlike other predistortion linearizer, the desired signals obtained from the harmonic generator are just the second harmonic intermodulation signals. It's explained below an expression.

$$\begin{aligned} H &= k_2 v_i^2 \\ &= k_2 A^2 + 0.5 k_2 A^2 [\cos(2\omega_1 t) + \cos(2\omega_2 t) \\ &\quad + 2\cos(\omega_1 + \omega_2)t + 2\cos(\omega_1 - \omega_2)t] \end{aligned} \quad (3)$$

Figure 1 shows a schematic of harmonic generator proposed in this paper. The harmonic generator is random controlled bias voltage to generate only desired second harmonic signals. Also, harmonic generator output signals are passed high pass filter, so that the original signal is cutoff and only second harmonic signals are passed. Figure 2 shows second harmonic signals measurement results in case of CW two-tone, and CDMA 1FA signals. The measured conditions are followed that harmonic generator input power is 0dBm, two-tone frequencies are 880MHz, 881MHz, and CDMA 1FA frequency is 880MHz. Consequently these are showed validity of the above harmonic generator.

The level of second harmonic signals ( $2\omega_1$ ,  $2\omega_2$ ,  $\omega_1+\omega_2$ ) generated from the harmonic generator is big enough to modulate with fundamental signal in the AM modulator and the variable gain amplifiers (VGAs) that control modulation factor are used in order to suppress the third order intermodulation of power amplifier.

Figure 3 shows a block diagram of the proposed linearization power amplifier. The IM generator uses the structure of vector modulator composed of in-phase and quadrature-phase components. The VGAs are controlled amplitude of second harmonic signals that is injected AM modulator. Finally the output signal of vector modulator is generated the IM signals. The desired signals ( $2\omega_1$ ,  $2\omega_2$ ,  $\omega_1+\omega_2$ ) are modulated with a fundamental signal in the AM modulator and the vector modulator output is generated the predistorted IMD3 signals and then two VGAs are used to control magnitude and phase of the predistorted IMD3 signals. This predistorter controls the amplitude and phase of intermodulation distortion components at the same time. The automatic level control (ALC) circuit at the input port stabilizes the device making constant IM signal in spite of sensitivity of incoming power level.

The in-phase and quadrature-phase components in vector modulator are expressed as follow.

$$\begin{aligned}
V_1 &= A [1+\alpha \cos(2\omega_1 t)+\beta \cos(2\omega_2 t)+\gamma \cos(\omega_1+\omega_2)t] \\
&\quad \cdot (\cos\omega_1 t+\cos\omega_2 t) \\
&= (A+0.5A\alpha+0.5A\gamma) \cos\omega_1 t \\
&\quad + (A+0.5A\beta+0.5A\gamma) \cos\omega_2 t \\
&\quad + 0.5A\alpha\cos(2\omega_1-\omega_2)t+0.5A\beta\cos(2\omega_2-\omega_1)t \\
&\quad + (0.5A\alpha+0.5A\gamma) \cos(2\omega_1+\omega_2)t \\
&\quad + (0.5A\beta+0.5A\gamma) \cos(2\omega_2+\omega_1)t \\
&\quad + 0.5A\alpha\cos 3\omega_1 t+0.5A\beta\cos 3\omega_2 t
\end{aligned} \tag{4}$$

$$\begin{aligned}
V_Q &= A [1+\alpha \cos(2\omega_1 t)+\beta \cos(2\omega_2 t)+\gamma \cos(\omega_1+\omega_2)t] \\
&\quad \cdot (\sin\omega_1 t+\sin\omega_2 t) \\
&= (A-0.5A\alpha-0.5A\gamma)\sin\omega_1 t \\
&\quad + (A-0.5A\beta-0.5A\gamma)\sin\omega_2 t \\
&\quad - 0.5A\alpha\sin(2\omega_1-\omega_2)t-0.5A\beta\sin(2\omega_2-\omega_1)t \\
&\quad + (0.5A\alpha+0.5A\gamma) \sin(2\omega_1+\omega_2)t \\
&\quad + (0.5A\beta+0.5A\gamma) \sin(2\omega_2+\omega_1)t \\
&\quad + 0.5A\alpha\sin 3\omega_1 t+0.5A\beta\sin 3\omega_2 t
\end{aligned} \tag{5}$$

where A : amplitude of CW two-tone  
 $\alpha$  : amplitude of  $2\omega_1$  signal among second harmonic signals  
 $\beta$  : amplitude of  $2\omega_2$  signal among second harmonic signals  
 $\gamma$  : amplitude of  $(\omega_1+\omega_2)$  signal among second harmonic signals

Equation (4) and (5) show that the IMD3 signals are generated by AM modulation of second harmonic signals and fundamental signals. So, when we only changed amplitude of second harmonic signals, it's controlled the inverse IMD3 signals of power amplifier. Figure 4 shows that when the second harmonic signals are changed amplitude with modulation factor, the predistorted signals are changed amplitude and phase simultaneously.

### III. THE RESULT OF EXPERIMENT

To show validity of the proposed linearizer, the cascade connection of Watkins-Johnson AH1 and Motorola MHL9838 is used as HPA, for which the gain and P1dB are 43dB and 37dBm, respectively. Watkins-Johnson AH1 is used as drive amplifier. The AM modulator is implemented 3dB hybrid coupler and Sony 1T362 varactor diode. And the harmonic generator is realized Watkins-Johnson AH1. The harmonic generator's bias voltage has properly controlled to obtain second harmonic signals. The delay circuit is compensated by coaxial delay line, which is about 12.4ns in this experiment. In the CW two-tone test, the IM3 component is cancelled more than 20dB for 7dB output power variation. Additionally the cancellation of the IM components is improved in the broad bandwidth and the wide dynamic range of the power amplifier. In the CDMA test, the spectral regrowth is improved more than 7dB at the 1FA and multi-FA signals. The proposed analog linearizer is limited to improve IM3 components only.

Figure 5 shows the two-tone results. The input frequencies are 880MHz, 881MHz with frequency

spacing 1MHz and output power is 28dBm/tone. It shows that IMD3 is cancelled out 26dB. Figure 6 shows the IMD3 improvements for an output power range from 28dBm to 35dBm in case of two-tone signals. Figure 7 compares adjacent power ratio (ACPR) of HPA with and without the proposed linearizer circuit, where the output power is 27.73dBm/FA and test frequency is 880MHz. The improvements in adjacent channel power ratio (ACPR) is about 9.1dB at  $f_0 \pm 885$ KHz. Fig. 8 compares adjacent power ratio (ACPR) of HPA with and without the proposed linearizer circuit, where the output power is 25.0dBm/FA and test frequencies are 878.125MHz, 879.375MHz, 880.625MHz, 881.875 MHz, respectively. The ACPR is improved 7.5 dB at  $f_0 \pm 885$ KHz offset frequency.

#### IV. CONCLUSION

In this paper, an analog linearizer using second harmonic signals feedforwarding is proposed. The harmonic generator extracts the second harmonic signals and modulates input signal with the extracted harmonic signals in AM modulator. Hence, the amplitude and phase of IM components are easily controlled simultaneously because the vector modulator consists of in-phase and quadrature-phase components, and its performance reduce the effort of retuning the attenuators and the phase shifters.

In the experiments, good IM cancellation characteristics are obtained for a wide dynamic range and different kind of signals. Also, when MMIC design technologies are used, the compact size of the linearizer is possible to implement.

#### ACKNOWLEDGEMENT

This work was supported by RIS program at University of Daegu.

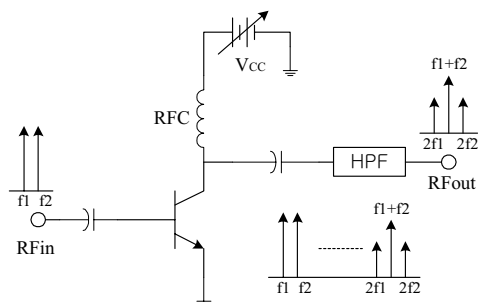
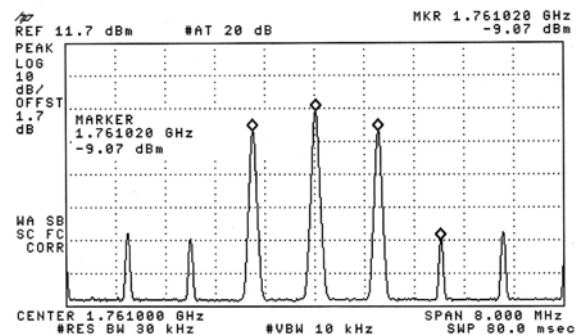

Fig. 1. A schematic of harmonic generator

#### REFERENCE

- [1] C. S. Aitchison, "The current status of RF and microwave amplifier intermodulation performance", in *IEEE Radio Freq. Integrated Circuits Symp.*, Boston, MA, pp.113-116, June 2000.
- [2] Y. Yang and B. Kim, "A new linear amplifier using low-frequency second-order intermodulation component feedforwarding," *IEEE Microwave Guided Wave Lett.*, Vol.9, pp.419-421, Oct.1999.
- [3] M. R. Mozzam and C. S. Aitchison, "A low third order intermodulation amplifier with harmonic feedback circuitry," in *IEEE MTT-S Dig.*, pp827-830, June 1996.
- [4] D. Jing, W. S. Chan, S.M. Li, and C. W. Li, "New linearization method using inter-stage second harmonic enhancement," *IEEE Microwave Guided Wave Lett.*, Vol.9, pp402-404, Nov.1998.
- [5] C. S. Aitchison, "Improvement of third order intermodulation product of RF and Microwave amplifiers by injection", in *IEEE Trans. Microwave Theory Tech.*, Vol.49, No.6, pp1148-1154, June 2001.
- [6] Tri T. Ha, *Solid-State Microwave Amplifier Design*, John Wiley, 1981.



(a)

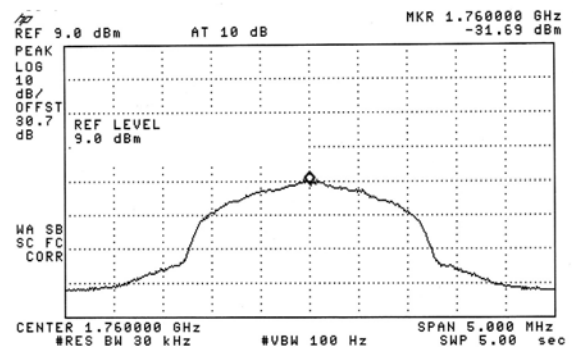

(b)

Fig. 2. Second harmonic signals at harmonic generator output (a) two-tone signals (b) CDMA 1FA signal

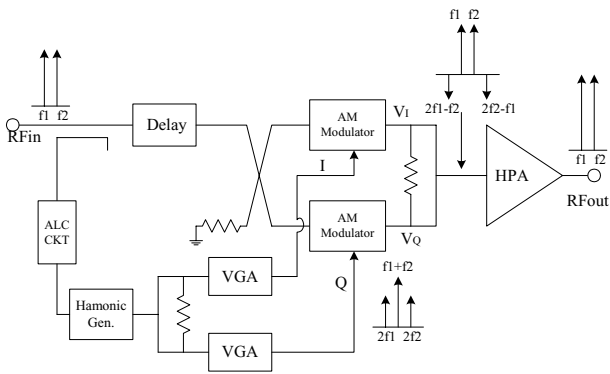

Fig. 3. A block diagram of the proposed linearization power amplifier

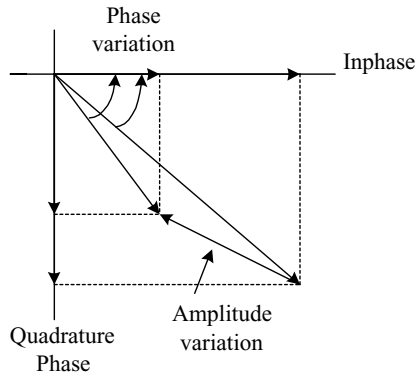
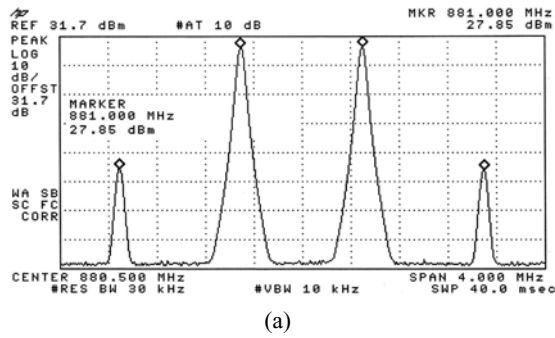
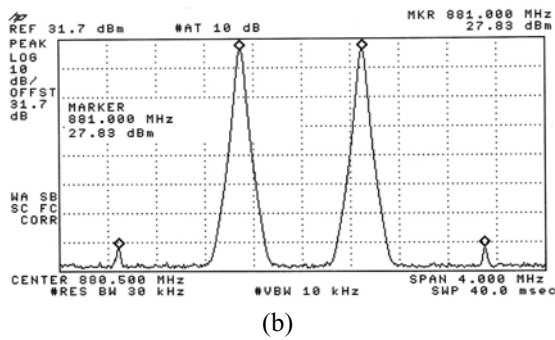

Fig. 4. Amplitude and phase variation of modulated signals



(a)



(b)

Fig. 5. Output spectrum of HPA at 28dBm/tone: (a)without linearizer (b) with linearizer in case of two-tone signals

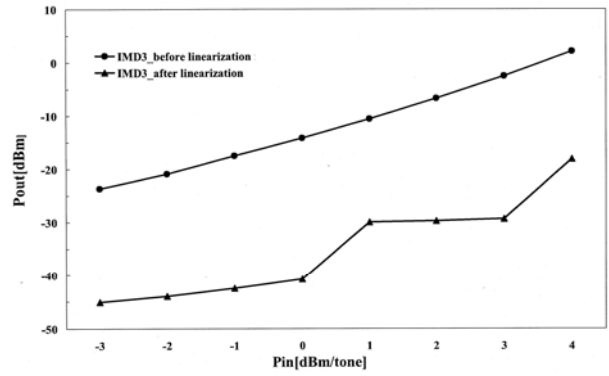

Fig. 6. IMD3 improvements for power variation in case of two-tone signals

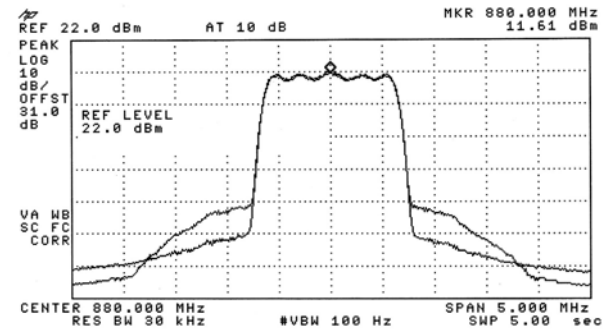

Fig. 7. HPA nonlinear characteristics with and without the linearizer in case of CDMA 1FA signal

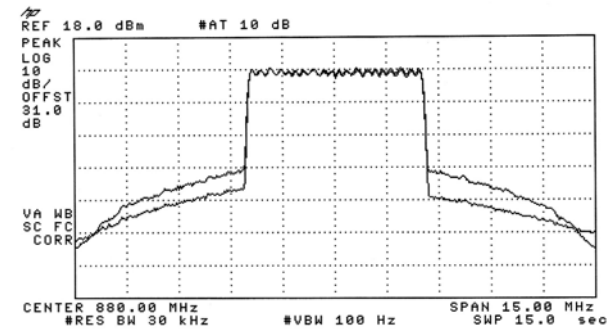

Fig. 8. HPA nonlinear characteristics with and without the linearizer in case of CDMA 4FA signals