

Advancement in T/R Module Interconnects

Andrew J. Piloto¹, Reiichi Yamada¹, Jerry Burgess², and Rick Hall²

¹Kyocera America, Inc., 8611 Balboa Avenue, San Diego, CA 92123, USA, 858-576-2600

²Corning Gilbert, Inc., 4201 N. 47th Avenue, Phoenix, AZ 85031, USA, 800-651-8869

ABSTRACT — Emerging RF systems which incorporate active phased array antenna subsystems demand major improvements in the microwave packaging and antenna interconnect technology used for the transmit/receive (T/R) modules. For active phased arrays to be viable, T/R module designs will need to be lower cost, lighter weight, and more producible as well as easily integrated into the antenna. The T/R interconnect technology presented herein provides for a new approach in both module and array design. Brazed with conventional braze materials, subminiature, blindmate RF connectors are attached to conventional cofired alumina and low temperature ceramic materials. This technology also addresses stringent reliability and maintainability as well as electrical requirements. The result is a packaging and interconnect technology that reduces life cycle cost and achieves improved performance from previous designs and reduces antenna assembly issues. Also discussed, is the incorporation of this interconnect technology to T/R modules into both a planar and conventional phased array antennas. In both cases, the individual T/R modules are ‘plugged’ into the array allowing for easy maintenance of the array.

I. INTRODUCTION

First demonstrated by Heinrich Hertz in 1886, a radar (**R**adio **D**etecting **A**nd **R**anging) is an electromagnetic system which uses reflected radio waves to measure range and bearing to a metallic or dielectric body by determining the time required for electromagnetic energy to travel to and return from the body. Today, Hertz’s discovery is now used in both radar and communication systems. Conventional radars generally have been operated at frequencies of about 220MHz to 94GHz, a spread of over eight octaves [1,2]. Due to increasing datarates, communication systems are also increasing in frequency. Legacy communication systems in the L through C-Band are now being augmented or replaced with systems operating between K and V or W Band. RF systems generally consists of five basic segments:

- **Digital Processor**
- **Transmitter**
- **Receiver**
- **Exciter**
- **Antenna (Array)**

A functional block diagram is shown in figure 1. Modern RF systems use an electronically scanned array (ESA) which replaces a conventional, mechanically scanned antenna. These systems are capable of performing

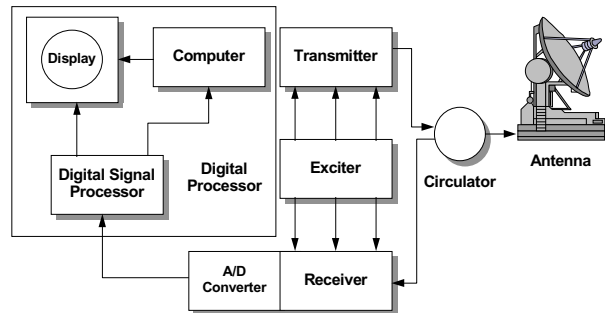

Figure 1. Modern Radar can be Segmented into Five (5) Basic Elements.

traditional radar functions and also supporting other radio frequency (RF) functions such as communications.

The **E**lectronically **S**canned **A**rray or ESA is the latest development in the ongoing evolution to replace conventional, mechanically scanned antennas. The concept of the ESA has been understood since World War II; however, it did not become feasible until the development of electronic phase shifters in the 1960's and digitally switched phase shifters in the 1970's [3]. The greatest operational improvement in this type of radar system is derived from the electronically agile beam of the ESA. With the advent **M**onolithic **M**icrowave **I**ntegrated **C**ircuit (MMIC) and **A**pplication **S**pecific **I**ntegrated **C**ircuit (ASIC) technology used in conjunction with advanced digital IC technology, MCM applications in modern radar are broadening. It was the development of the transmit/receive (T/R) module in the late 1970's/1980's using advanced MMIC's and ASICs that enabled the incorporation of microwave amplifiers within the antenna itself, overcoming the power loss typically associated with phased arrays.

Figure 2 illustrates the basic requirements of electronic construction within a specific portion of the RF system. In the case of microwave MCM's such as T/R modules, the operating frequency and associated wavelength is on the order of magnitude of the circuit dimensions; therefore, physical layout, wirebond loop heights, epoxy thicknesses, etc., all play critical roles in the development of the MCM. Generally microwave MCM's combined GaAs MMIC's and silicon control devices in order to perform a desired function. Advanced packaging and interconnect technology plays a key role in the development of the microwave MCM. Improvements in conventional packaging include lower loss materials,

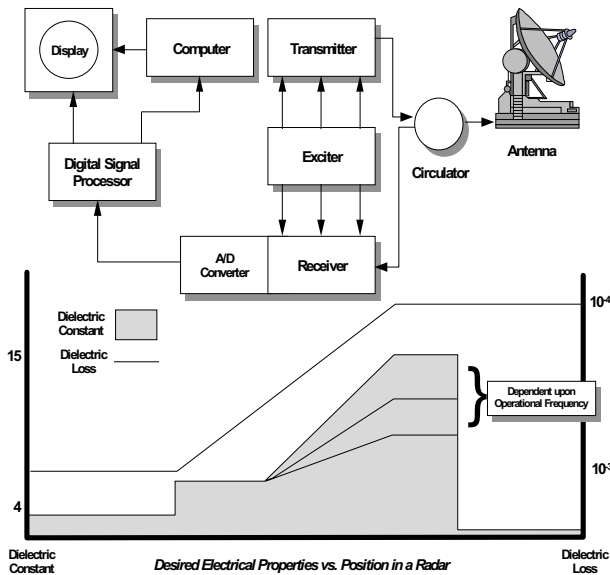

Figure 2. Desired MCM Electrical Characteristics Vary with Position in a Radar System.

variable dielectric constants, and thermal expansion matching to GaAs [4]. Below are some "truisms" concerning the design of microwave MCM's as described by Bilski [5].

- *The mechanical design and electrical performance of microwave [analog] MCMs are closely interrelated because of the short wavelengths involved*
- *Tolerances desired in the circuit design are difficult to achieve in practice*
- *A team of electrical, mechanical, and process engineers is important for microwave MCM design.*
- *Ground Continuity is of vital importance to good high frequency performance*

Recent advancements in T/R module packaging have demonstrated the viable and utility of cofired ceramic technology.[6][7]

To avoid high antenna assembly costs, blindmate RF interfaces have been adapted for use in the integration of the T/R Module to the antenna manifolds and radiators. The development and adaptation of these interfaces is described herein.

II. PHASED ARRAYS AND T/R MODULES

As shown in figure 3, there are two types of phased arrays or ESA's: a passive phased array and an

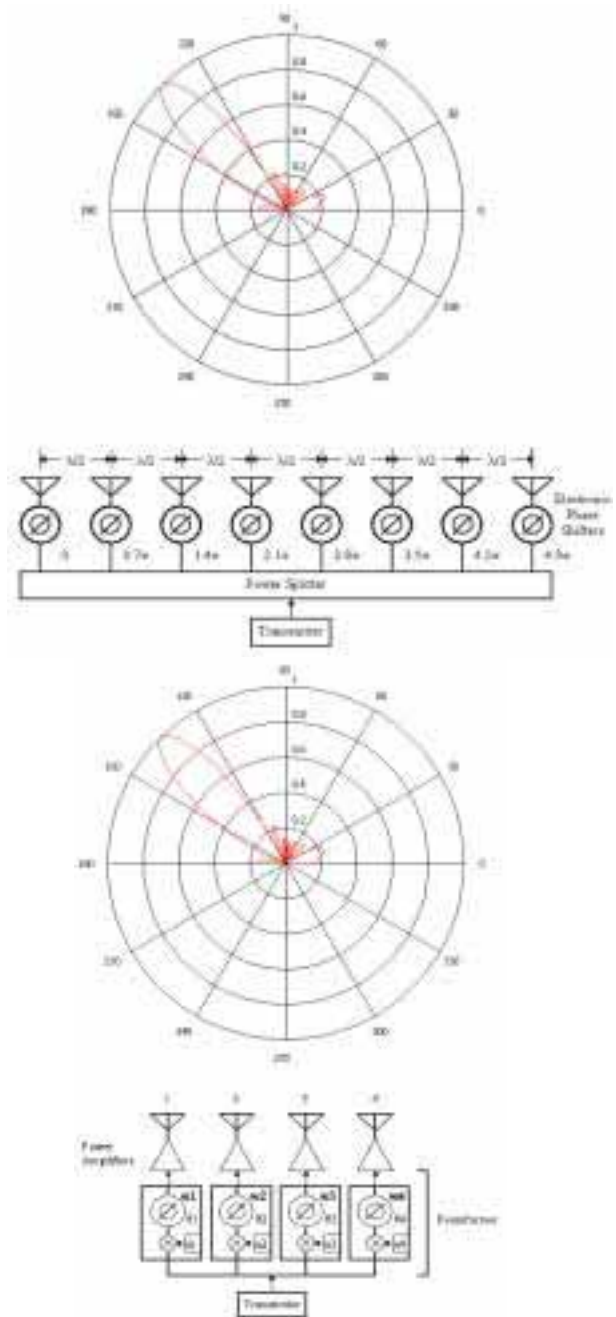

Figure 3. There are Two Types of Phased Arrays: PASSIVE (top) and ACTIVE (bottom).

active phased array. A passive phased array typically contains digitally switched ferrite phase shifters with no localized active element at each radiating site. A significant limitation is the loss at each radiating site due to the phase shifter. As a result, a high power transmitter behind the antenna is required to make passive phased arrays viable. The active phased array or active ESA (AESA) overcomes these limitations by placing microwave amplifiers directly into the array in the form of a very complex microwave MCM - the T/R module. The AESA uses the distributed amplifiers to eliminate the need for a large portion of high power radar transmitter and portions of the radar receiver. An RF system block diagram changes significantly in this type of system as shown in figure 4.

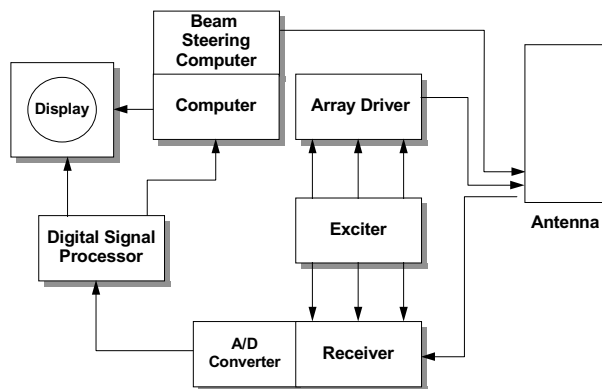

Figure 4. The Active Phased Array Radar Utilizes RF Amplifiers in the Antenna for Distributed Transmitter/Receiver Functions

The RF amplifiers combine with very high speed solid state phase shifters and attenuators along with their associated direct current (DC) power regulation and

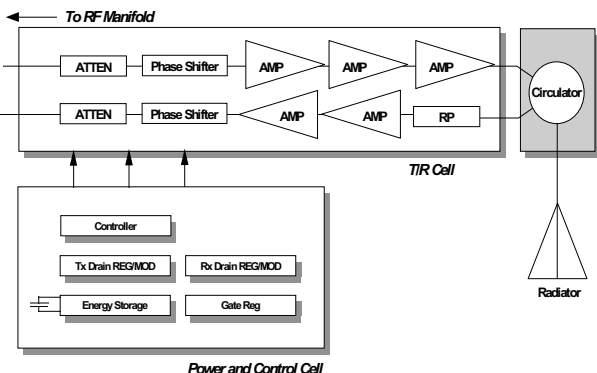

Figure 5. T/R Modules Combine RF Amplifiers along with Very High Speed Solid State Phase Shifters and Attenuators and with associated DC Power Regulation and Control Logic Circuits

control logic circuits to form the T/R module. A typical block diagram for a T/R module is shown in figure 5. As described by Longuemare [3], the increase in AESA capability due to the T/R module over a mechanically scanned antenna is significant. A mechanically scanned antenna may take as long as eight (8) seconds to sweep an area of coverage. Gallium Arsenide (GaAs) phase shifters in an AESA can change phase states in less than 50 nanoseconds and thus redirect the beam to anywhere in the field of view [3]. The distributed transmitter nature of the AESA also provides for graceful degradation of the RF system. Typically, the failure of an active elements in the AESA disable only a single T/R module. The loss of one element has a negligible effect on radar performance. Up to 10 percent of the T/R modules may fail before performance degradation becomes noticeable [3]. In a typical radar, several thousand T/R modules are placed in an array to form an AESA. Since T/R module spacing in the array is a function of the operating frequency, the challenge is in the incorporation of passive and active RF and DC components in a severely constrained volume.

T/R module construction is often dictated by operational frequency. However, since the T/R module

represents the last transmission and first reception point and therefore gets the highest operating frequency in the RF system and contains considerable amounts of digital control and power conditioning, the selection of MCM packaging technology and array interconnect is critical. Generally, radar modules contain localized digital control, energy storage and regulation for stability while communication modules do not. In order to maintain low sidelobe levels and minimize grating lobes, these modules are placed in at half-wavelength grid ($\lambda/2$). These spacing requirements places many constraints on both the array-level interconnect as well as the T/R module packaging.

With hundreds, thousands and even tens of thousands of modules populating a given array, the need for a simple, high-performance RF interface is required. Many existing and emerging requirements dictate that the interfaces “plug-and-play” with both “tile” and “brick” based T/R Module configurations whose orientations are perpendicular and parallel to the radiators respectively. A tile-based configuration is shown in figure 6. The interface must also provide a low

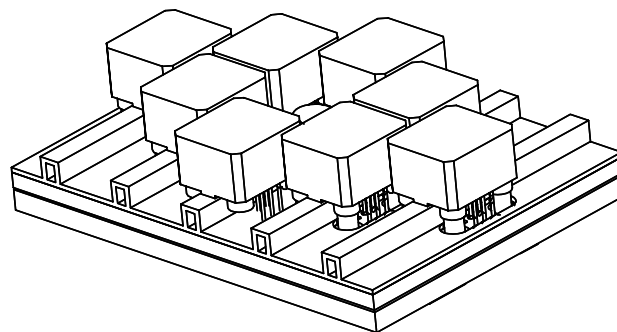

Figure 6. Current and Emerging Module Intergration Scheme Require “Plug and Play” T/R Module (Tile Array Shown)

Noise, highly isolated, broadband interface to the array RF manifolds. The GPO®/GPPO® has been developed and successfully integrated with the brazing technology to support such requirements.

III. CURRENT BLINDMATE STANDARD: THE GPPO

With widening RF bandwidths, the increasingly preferred method of interfacing the T/R module to the antenna array is with a blindmate RF connector. The GPO®/GPPO® series of microwave connectors fits the bill. The GPO®/GPPO® series of connectors are a sub-miniature, push-on, microwave interconnect system that exhibits very high performance in the RF, microwave and millimeter wave bands. A comparison of the two connector series is shown below in Table I. The connector consists of 3 main parts:

- **Shroud**
- **Blindmate (often referred to as a ‘Bullet’)**
- **Pin**

GPO®	GPPO®
Impedance 50Ω	Impedance 50Ω
Center-to-center spacing of 0.170"	Center-to-center spacing of 0.135"
Blindmate interconnect weight ~ 0.17g	Blindmate interconnect weight ~ 0.09g
VSWR = 1.15:1 to 26GHz, <1.5:1 to 40GHz	VSWR = 1.1:1 to 26GHz, 1.3:1 to 50GHz
Insulation Resistance = 6mΩ MAX	Insulation Resistance = 6mΩ MAX
Designed to accommodate radial and axial misalignment with negligible VSWR change - 0.01" typical	Designed to accommodate radial and axial misalignment with negligible VSWR change - 0.01" typical
Full Range of Adapter Support	Adapters available to SMW, 2.4mm and 1.85mm connectors
Temperature Range: -65C to 165C	Temperature Range: -65C to 165C

TABLE I: GPO®/GPPO® COMPARISON

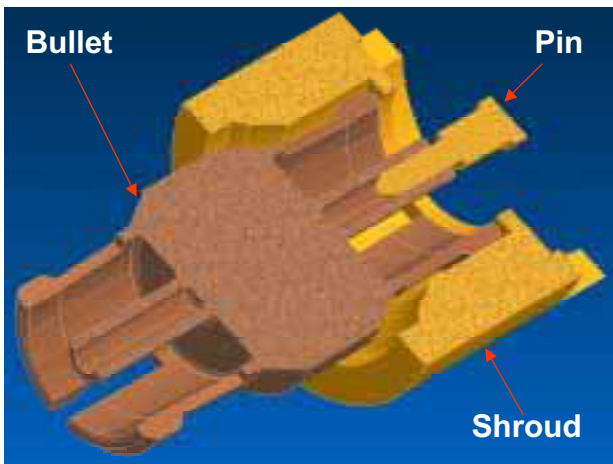

Figure 7. GPO®/GPPO® Connector Systems Consist of Pins, Shrouds, and Bullets.

An illustration of the connector is shown in figure 7. The captivation system developed for the GPO® and GPPO® interconnect systems that provides predictable levels of retention without the use of bulky coupling nuts. This feature is characterized as the connector's "detent". The "detent" is the mechanism that temporarily keeps one part of the connector systems in a certain position relative to that of another, and can be released by applying force to one of the parts. The GPO® product is designed with 3 available detent levels, and 2 detents exist within the smaller GPPO® series. The detent was designed by incorporating a ring in the male connector (commonly known as the shroud). This detent ring interacts with the mating connector 2 (female contact) to captivate the pair together. Each of the

in the GPO® series), and smooth bore (or zero detent) provides a different level of force required to mate and demate the connectors. Empirical data showing the insertion/extraction forces is shown in Table II. Proper care should be used when designing your system to select the required forces for mating and demating. The level of detent selected will also have an impact on the number of typical engage/disengage cycles you can expect for your interconnection to survive.

Both GPO® and GPPO® have been adapted to be brazed onto T/R Module packages with standard brazing technology. As shown in figure 8,

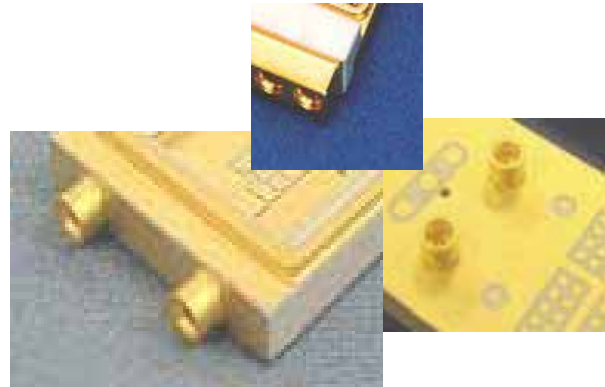

Figure 8. RF Connectors Brazed to Top/Bottom or Side of the T/R Module Package.

configurations include side-brazed and top/bottom brazed. When brazed to the top or bottom of the T/R

DETENT LEVEL	Mate GPO®	Mate GPPO®	Demate GPO®	Demate GPPO®	No. of Mate Cycles GPO®	No. of Mate Cycles GPPO®
Full Detent	9.0 lbs.	4.5 lbs.	7.0 lbs.	6.5 lbs	100 max.	100 min
Limited Detent	7.0 lbs	N/A	5.0 lbs	N/A	500 max	N/A
Smooth Bore	2.0 lbs	2.5lbs	0.5 lbs	1.5 lbs	1000 max	500 min

TABLE II: Different Detent Levels Provide Different Insertion/Extraction Forces.

module an orthogonal RF transition interfacing the connector, a coaxial structure in the module package and ultimately stripline or microstrip is required. When brazed to the side, an in-line RF transition to stripline is achieved. The ground shroud and the center conductor pin of the connector are separately machined and then brazed onto the substrate. In some cases, the pins are brazed first with eutectic copper silver braze at 780C. In the case of lower temperature ceramic materials, gold/tin braze is used. Shrouds were then attached using carbon graphite plug as the spacer. In other cases, the pins and shrouds are brazed simultaneously. Most important is the concentricity between the pin and the shroud.

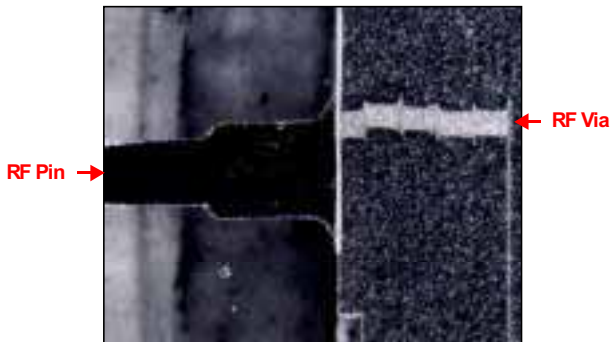

Figure 9. Top/Bottom Brazed GPPO Interfaces to Coaxial Structure in the Package.

In order to reduce the capacitance between the RF center conductor (pin) and ground (the shroud), the diameter of the pin braze pad was limited and the room for the braze fillet formation was therefore smaller than normal Pin Grid Array pin brazing. A close-up cross section of the RF pin for a bottom/top brazed module is shown in figure 9. An overall view of both the top/bottom and side brazed RF interface is shown in figure 10.

The impedance mismatch at the interface necessitates that the package connector transition be compensated or tuned. Examples of both a narrow band X-Band match and broadband match is shown in figure 11. Depending on line lengths in the packages, the packaging materials and subsequent transitions, insertion losses from <math><0.1\text{dB}</math> to >1.0dB over any given band have been demonstrated.

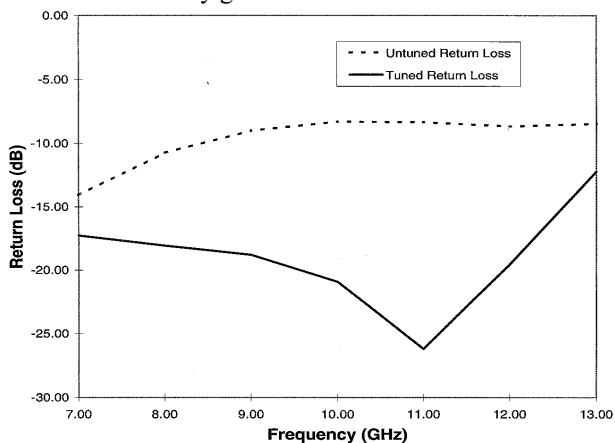

Figure 11. Brazed Connector Interfaces are Matched for Optimum Performance: Connector to Coaxial Structure (left) and Connector to Stripline (right)

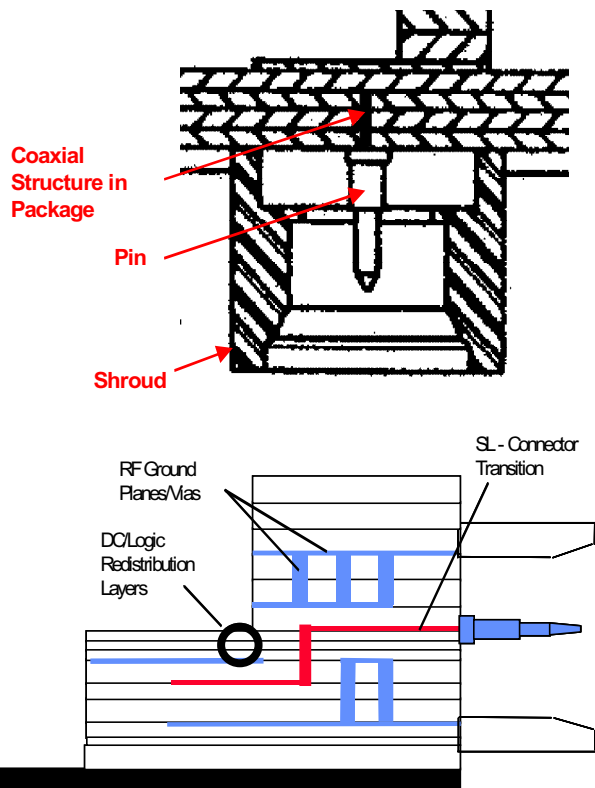

Figure 10. Top/Bottom Brazed RF Connector Interfaces with Coaxial Package Structure (top), Side Brazed RF Connector Interfaces with Stripline (bottom).

IV. NEXT GENERATION LOW PROFILE CONNECTOR: THE CGP CONNECTOR

A new push-on coaxial connector interface in development will allow further reductions in space and weight. The new patent pending interface, currently identified as CGP, is 33% smaller and 28% lighter than the GPPO®. A comparison between the GPPO® and CGP is shown in figure 12.

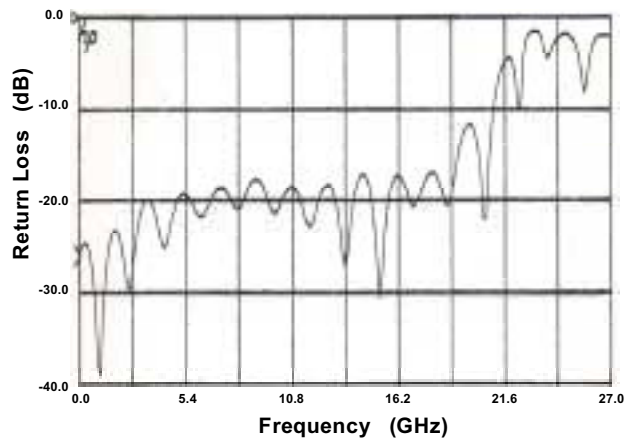



Figure 12. New CGP Connector 33% Smaller than GPPO.

With a center-to-center spacing of 0.080" it is an ideal candidate for applications with challenging space constraints such as 3D, millimeter wave (MMW) AESAs. As shown in figure 13, incorporation of the CGP would produce significantly thinner modules, thereby enabling a broadband low profile RF interface suitable for emerging MMW AESA. The CGP is currently undergoing characterization; however, mode free electrical operation in excess of 100 GHz is expected. Various CGP configurations are currently being sampled for evaluation.

V. CONCLUSIONS

Modern RF systems are beginning to utilize active electronically scanned arrays. The development of MMIC and ASIC semiconductor technology has given rise to wider spread usage of mixed mode MCM's known as T/R modules. The challenge to the T/R module designer is the incorporation of passive and active RF and DC components within a module.

Additionally, the relationship between the materials, mechanical design and electrical performance of the module is of paramount importance as well. Finally, the T/R module must easily integrate into the antenna. The subminiature, blindmate, GPO® and GPPO® microwave interconnect series have been successfully adapted in the conventional cofire-ceramic and brazing technology – a staple of T/R module packaging. This enables the T/R module to “plug and play:” with antenna manifolds and radiators

ACKNOWLEDGEMENTS

The authors wish to acknowledge the contributions and encouragement of Heather Horsfall and Carolyn Case from Corning Gilbert, and Chong-il Park and Derek Mrazek from Kyocera America to this paper.

REFERENCES

- [1] Skolnik, Merrill I., "Introduction to Radar Systems", McGraw-Hill Book Company 1980
- [2] Kotaki, Minoru and Takimoto, Yukio, "Automotive Anticollision Radar", Applied Microwave, Fall 1992, pp70-82
- [3] Longuemare, R. Noel, "Advanced Phased Arrays Redefine Radar", Defense Electronics, April 1990, pp 63-66
- [4] Schwartz, Bernard, "Conference Studies Next Generation of Electronic Packaging", Ceramic Bulletin, Vol 65, No. 7, 1986
- [5] Bilski, Stacey M., "Microwave Tutorial", Hybrid Circuit Technology, June 1988, pp 19-25
- [6] Piloto, Andrew, J., et.al. "Advanced T/R Module Packaging for Active Phased Array Antennas", IMAPS 1996, Boston, MA
- [7] Hemmi, Chris, Dover, Thomas, R., German, Fred, Vespa, Anthony, "Multifunction Wide-Band Array Design" IEEE Transactions on Antennas and Propagation, Vol 47, No. 3, March 1999

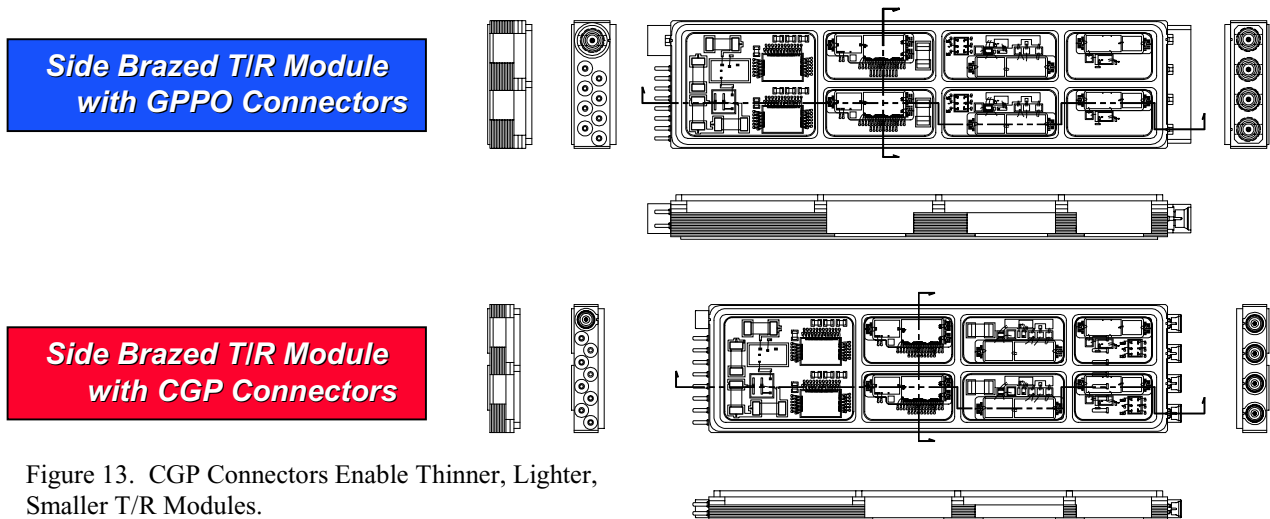

Figure 13. CGP Connectors Enable Thinner, Lighter, Smaller T/R Modules.