

4W TX/RX Multi Chip Module for 6-18GHz Phased Array

M. Bartocci, G. De Santis, G. Giolo, L. Rossi and M. Gemma

Elettronica S.p.A. Microwave Department, Rome, 00131, Italy (Via Tiburtina Km13.700)

C. Mondolot, L. Roussel

THALES Microwave Department, Massy Cedex, 91349, France (29, avenue Carnot)

Abstract — A complete Tx/Rx module for avionic and naval applications was developed and tested. A multifunction PHEMT MMIC chip set was realized. Multi chip integration in hermetic MoCu package was adopted in order to reduce cost, space and assembly time. High performances in the Tx channel was achieved using a 4W wideband amplifier.

I. INTRODUCTION

The Tx/Rx module is a reciprocal Transmit/Receive device connected to the radiating elements in a phased array antenna. Since systems use several hundreds of antennas requiring an equivalent number of Tx/Rx modules, then it is clear that the cost of each module has to be kept low.

The principal functions of this module are: generate high transmission power, up to 4W; apply suitable phase shift to signals in both transmit and receive modes for beam forming purposes; introduce attenuation in each path to modulate either the input, or the output power and to control dynamic range.

In the actual production module, MIC components and MMIC amplifiers are assembled according to the classical microwave integration process. Despite such a well defined process and its wide use in military and commercial application, this solution requires high RF level and numerous control interconnections. Following this approach, the production module is very expensive because testing, assembling and alignment phases need too much time and skilled technicians.

In order to reduce testing and assembling times a new module has been designed with the aim of reducing costs and improving electrical performances. A complete custom chip set has been developed using a 0.25 μ m PHEMT technology. In each chip several microwave functions have been integrated like SPDT, phase shifter, digital

attenuator, low noise amplifier, high power amplifier. As a consequence, RF interconnections are reduced while space and mismatching are minimized.

Using MoCu package to assembly multifunction MMICs it is possible to keep Tx and Rx channels separated. In this way all mechanical parts and control interconnections are simplified.

Using an ASIC assembled on a control board circuit makes it possible to interface the external control lines with the command lines in microwave subassemblies; so different operation modes are set.

The module is compatible with automatic pick and place assembling, automatic test and alignment procedures and thus is suitable for mass production.

II. MODULE ARCHITECTURE

Fig.1 shows the module block diagram; it is configured to feed one of two different types of antennas. Depending on external controls, it is possible choose the transmit or receive mode and connect it to the appropriate antenna.

A 4 bit phase shifter is shared by the Tx and Rx channels permitting beam forming on the array.

A 4 bit attenuator in the Tx channel allows to modulate the input power in the final subassembly.

In order to improve performances of detection systems, it is important to reduce the amplitude of the secondary lobes; to meet this requirement, a non uniform distribution of the signal amplitude on the array is necessary. To insure the right amplitude distribution on the array an attenuator is used in the Rx mode. The attenuator was designed with a phase invariant characteristic because it has to modulate the amplitude of the signal without modifying its phase.

Moreover, using this type of attenuator it is possible to adjust the gain of the receiver channel in order to guarantee linearity over the whole dynamic range.

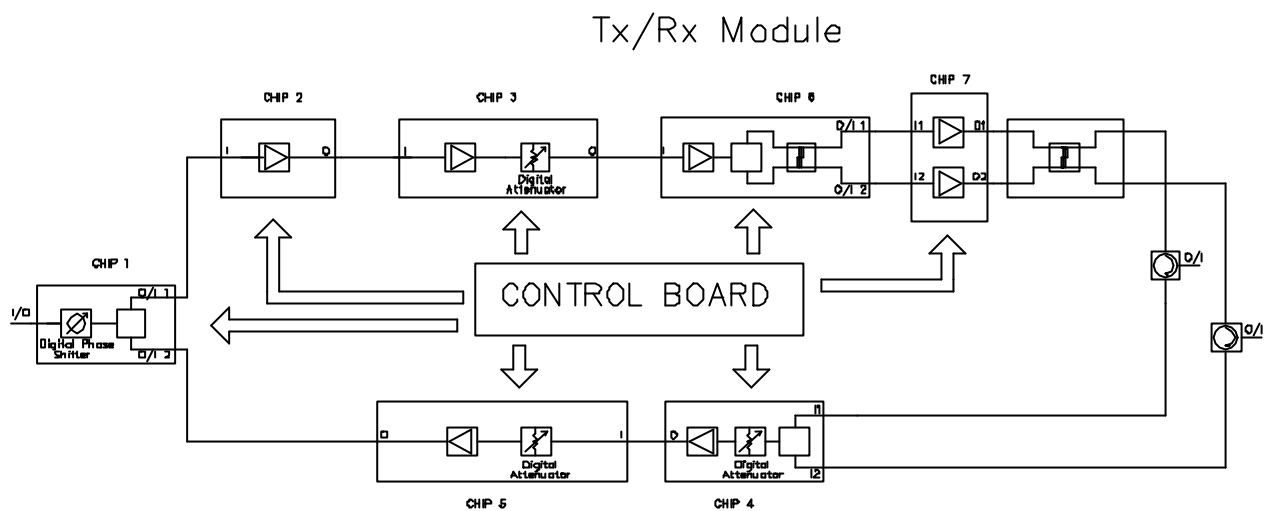

Fig. 1 Block diagram

The module is composed of three RF subassemblies, two of them for the Tx channel the other for the Rx channel.

Each subassembly, built in a hermetic custom MoCu package, contains up to three multifunction MMICs. The chip set has been divided as follow:

- Low power Tx subassembly includes Chip 1, 2 and 3;
- High power Tx subassembly includes Chip 6 and 7;
- Rx subassembly uses Chip 4 and 5.

To avoid LF oscillations, bypass capacitors are mounted in each subassembly; moreover, alumina circuits like hybrid or interconnection lines are included as shown in Fig2.

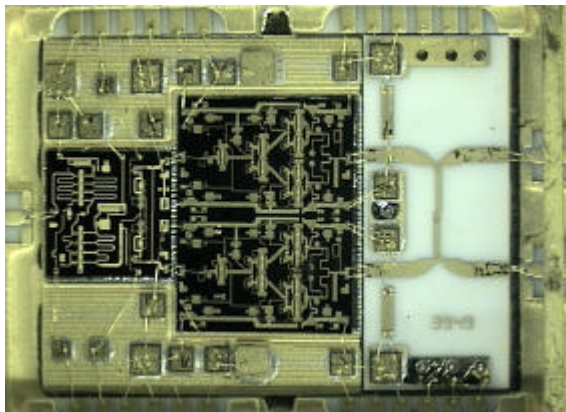

Fig. 2 High power Tx subassembly

In order to meet the fast settling time requirement (~20ns) between all functions, an ASIC has been developed.

In this way all gate voltages on amplifiers, switches, attenuators and phase shifter are controlled.

A dual wideband power amplifier with 2.8W output power per channel was employed. By means of an ideal balanced configuration, a 5.6W power level was obtained at the high power Tx subassembly output.

Considering the SMD circulator and transition insertion loss, the module delivered an output power of 4W.

III. MULTIFUNCTION MMIC AND CONTROL BOARD DESIGN

In order to develop a chipset composed of 7 multifunction MMICs the 0.25um PHEMT Triquint (Dallas – TX) process was adopted.

In receiving channel there is the first MMIC with a switch, a 20dB attenuator and the first LNA amplifier stage. This choice allows an input dynamic range better than 60dB.

A second amplifier stage, with a 3 bit attenuator and another SPDT switch is in the second receiving MMIC.

The Rx channel terminates with a 4 bit phase shifter MMIC with a switch common to both transmitter and receiver path.

In the transmission channel, after the phase shifter there is a MMIC containing a linear amplifier, followed by another MMIC with an amplifier working in saturated region and a 4 bit attenuator. In this way it is possible to control the input power to the following MMIC. This is the driver for the 4W final amplifier stage, for which Triquint TGA9092 MMIC amplifier was adopted. Changing the attenuation value in the Tx channel it is possible to introduce an amplitude modulation in the output power.

All MMICs, except the final power amplifier, have been designed using SerieIV software; special attention was paid to avoid undesired oscillations by means of the S-probe technique. This was used to analyze the impedance present in all the circuit nodes. To be sure that no oscillations were generated in the critical frequency range, negative real part impedances have been carefully eliminated.

A control board was designed to perform all the functions required by this chipset, i.e. T/R switching, transmitted power control and phase control.

All gate voltage levels are stored in a digital word and written in an EEPROM during final alignment. The ASIC reads these information and, using an internal DAC, can set the right voltages at the right gates in order to control all the amplifiers. Finally, to avoid damages due to power supply failures, the ASIC contains the control logic to turn off the +8V power supply if the negative supply is interrupted.

IV. MECHANICAL AND PACKAGING

The Tx/Rx module was mounted in aluminum housing in order to guarantee low weight, low costs and good thermal conductivity. A thermal interface between the MMICs manufactured in GaAs (CTE=6.5 ppm/°C) and the aluminum housing (CTE=24 ppm/°C) was necessary. Custom micro packages based on Cu₂₀Mo₈₀ (CTE=8 ppm/°C) were adopted. Packages were glued to the aluminum housing using a conductive film and thermal cycles were conducted without exhibiting any failures for 2000 hours.

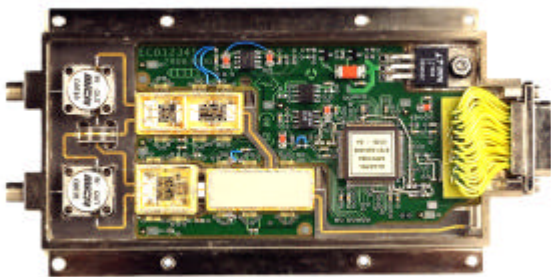

Fig. 3 Assembled Tx/Rx module.

Since 20W are dissipated only by the high power amplifier and taking in account that the total power dissipated is around 26W, then it is clear that the reliability of the module is determined by the junction temperature in

the high power amplifier. An accurate thermal analysis was performed: firstly, a full model of the module was built in order to calculate the temperature at the base of each MMIC; these temperatures were then used to estimate the junction temperatures of the high power amplifier. For this purpose a thin model of the high power amplifier was used.

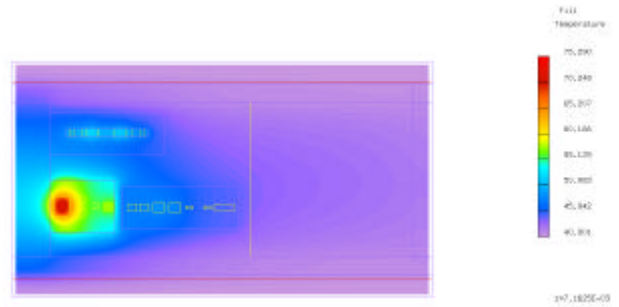

Fig. 4 Thermal analysis for the module: heat sink on total bottom surface maintained at 40°C; temperature reached at the base of the MMIC is 75°C.

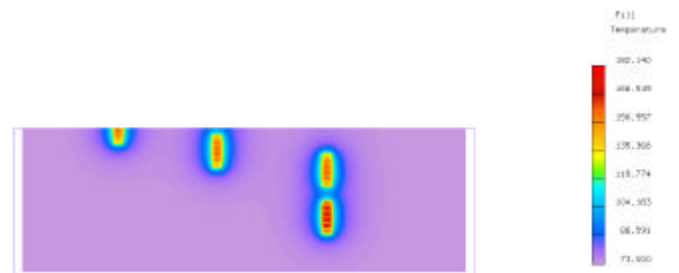

Fig. 5 Thermal analysis of the thinly modeled high power amplifier. T_j=180°C

These data make it is possible to estimate the medium time to failure (MTTF) using Triquint foundry pHEMT life test results. An MTTF of 40.000 hours is achieved in the worst case when the module is always in the transmit mode (CW).

V. MEASUREMENTS

The first prototype was tested and a typical 35.5dBm power output was obtained as shown in Fig. 6. The test results show different output powers depending on input power and selected channel (left or right).

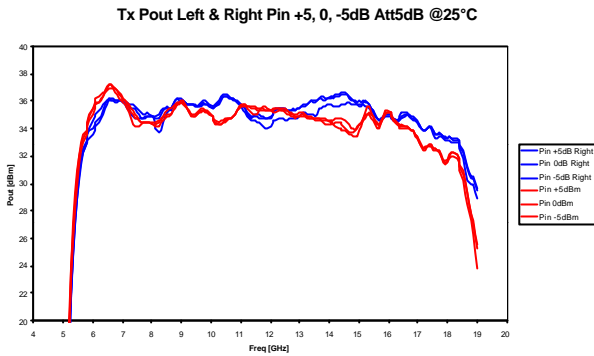

Fig. 6 Power outputs for Left and Right channel.

In the Rx channel the phase invariant attenuator is a key component because it ensures the capability of reducing secondary lobes on the array. Fig. 7 and Fig. 8 show its performances in terms of normalized gain and phase variation.

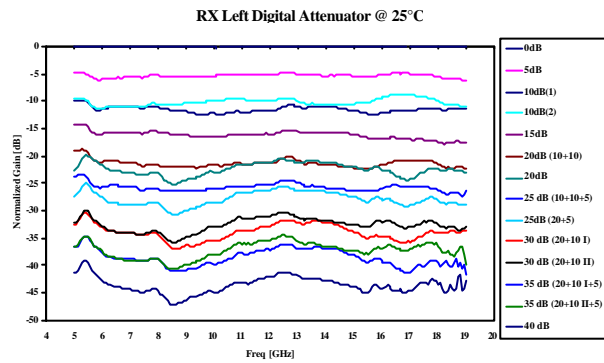

Fig. 7 Attenuation step for the phase invariant digital attenuator.

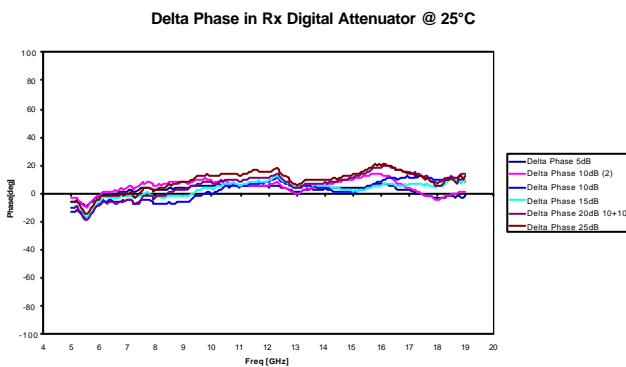

Fig. 8 Phase variation introduced by each step of the Rx digital attenuator.

Fig. 9 show the performance of the phase shifter; tests were conducted for 22.5° step and, in the worst case, a max 8° RMS error was obtained.

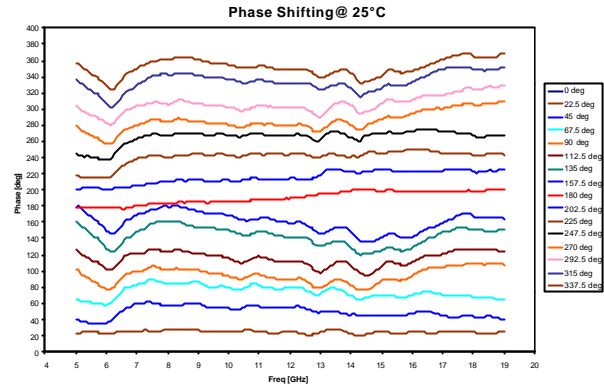

Fig. 9 Phase step available in the phase shifter.

VI. CONCLUSION

The first prototype of a 4W receive-transmitter module was realized and characterized. The module features give the possibility to realize a complete phased array antenna with more than 200 elements.

Electronica S.p.A. and Thales Microwave have planned to develop and test a preseries of several modules in order to validate a mass production line.

REFERENCES

- [1] M. I. Skolnik, "Introduction to radar systems" McGraw-Hill, 1981.
- [2] A. R. Barnes, M. T. Moore, M. B. Allenson and R. G. Davis "A compact 6 to 18GHz Power Amplifier Module with 10W Output Power" 1999 IEEE MTT-S Digest, pp. 959-962.
- [3] S. Morioka, Y. Sawa "Surface Mount Package for High Frequency Band", Microwave Conference, 1999 Asia Pacific, Page(s): 958 -961 vol.3
- [4] Jhon L.B. Walker "High-Power GaAs FET Amplifiers", Walker, John L.B. Editor, 1993