

A monolithic integrated 180 GHz SiGe HBT Push-Push Oscillator.

P. ROUX¹, Y. BAEYENS², O. WOHLGEMUTH³ and Y.K. CHEN².

¹Lucent Technologies – Bell Laboratories, 16 Av. Descartes, 92352 Le Plessis Robinson, France.

²Lucent Technologies – Bell Laboratories, 600 Mountain Ave., Murray Hill, NJ 07974, USA.

³Lucent Technologies – Optical networking group, Thurn and Taxis Strasse 10, Nuernberg, 90411 Germany.

Abstract — A fully integrated single-ended output push-push oscillator is realized using an advanced 0.2 μ m SiGe HBT process. Up to -5 dBm output power is achieved at 180 GHz using a technology with a transition frequency f_T of 200 GHz and maximum oscillation frequency f_{MAX} of 275 GHz. Preliminary phase noise measurements show a phase noise of less than -90 dBc/Hz at 1 MHz offset from the 180 GHz carrier.

I. INTRODUCTION

Voltage controlled oscillators are essential building blocks for next generation mm-wave radar and telecommunication systems.

To achieve the best compromise between a highest oscillation frequency, good output power, good phase noise and fully integrated design, we have chosen a push-push oscillator topology, in which the outputs of two oscillators coupled in anti-phase are combined to yield a strong 2nd harmonic output signal, allows to extend the useful frequency range of available transistor technology [1-4]. Furthermore, the resonator operates at half of the output frequency, which results in higher Q-factors and improved phase noise.

II. CIRCUIT DESIGN

The schematic diagram of the VCO is shown in figure 1. It is similar to that of the SiGe HBT push-push VCO published in [4].

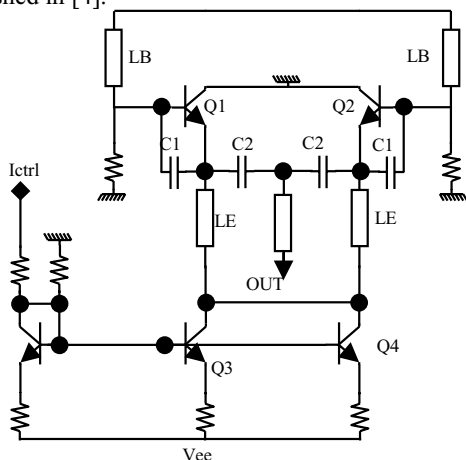

Fig. 1. Schematic diagram of the push-push oscillator (vco3).

A strong second harmonic push-push output is obtained at the virtual differential ground node of a differential LC-type Collpits oscillator. The 2nd harmonic

can be extracted at any virtual ground node for the common mode. In this case the 2nd harmonic is extracted between the capacitors at the emitter to improve output power and fundamental rejection compared to the end of the base line resonator (LB), which introduces additional losses.

Transmission lines are realized as thin-film microstrip lines with a lower metallization as ground plane and the 2.5 μ m thick top metallization layer as signal line to minimize losses.

The negative resistance is obtained by loading the emitter of the Q1 and Q2 with a capacitance formed by the MIM capacitor C2, which permits the output to be AC-coupled with any additional element. As in [4], the microstrip transmission lines LE are designed to be quarter wavelength at the fundamental oscillation frequency, such that the differential short at the collector of Q3 and Q4 is transformed to an open at the fundamental frequency.

The MIM capacitor C1, bypassing the base-emitter diode, limits the non-linear up conversion of noise at the base node. In the present design, the collector is shorted which allows the use of a large device (0.2x10 μ m²). As a drawback, only the second harmonic can be extracted. However, using this topology, we expect to improve output power, phase noise, pulling and improve the maximum frequency oscillation reachable for a given device technology.

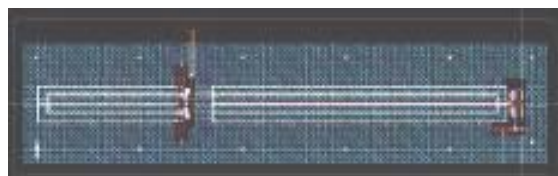

Fig 2: Layout of the VCO3.

The layout has been carefully drawn to obtain fully symmetric layout and to minimize parasitics. We have simulated only 2% frequency shift between the schematic with and without extracted parasitics from layout. The chip size of VCO3 is 200 x 800 μ m² without pads.

III. CIRCUIT RESULTS

Circuits were realized using an advanced 0.2 μ m SiGe HBT foundry process. This process features a high performance NPN HBT with a transit frequency $f_T = 200$ GHz and $f_{MAX} = 275$ GHz [6].

The output spectrum measured at the single ended 2nd harmonic output using on-wafer WR-08 waveguide probe and a 170 – 200 GHz downconverter, is shown in figure 3. This measurement was not corrected for the WR-08 waveguide probe and downconversion mixer loss, estimated to be at least 12 dB. A spectrum with about –5 dBm output power at 180 GHz is obtained for a total power consumption of 120 mW.

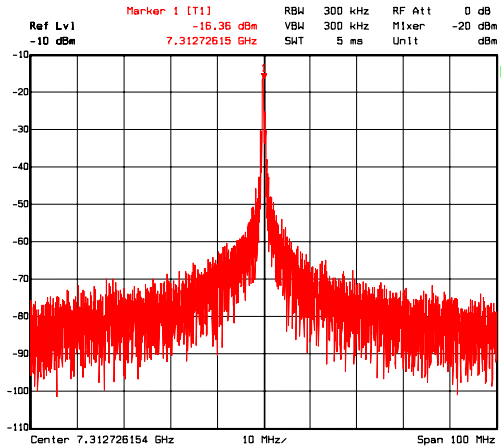

Fig. 3. Downconverted spectrum (LO=186 GHz) of VCO at 2nd harmonic single-ended push-push output (V_{EE}:-3.4V, total current : 35 mA, not corrected for 12 dB conversion loss).

There is a good agreement between simulations and measurements. In our case, the measurement gives 179 GHz compared to a simulated oscillation frequency of 184 GHz @ V_{EE}=-3.3 Volt. The oscillation frequency and associated output power are shown in figure 4 and 5, respectively as a function of the negative supply and the current control voltage. No varactor tuning was implemented in the present oscillator, therefore the oscillation frequency can only be tuned by about 1 GHz, for instance using the current control pin of the current source (figure 5).

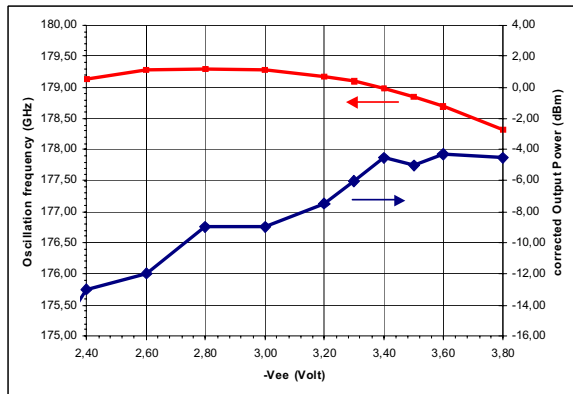

Fig. 4. Corrected output power and oscillation frequency vs negative power supply.

As shown in figure 4, a zero pushing is achieved for a negative power supply at –2.8 Volt, which permits to minimize the up-conversion of the noise. Unfortunately, the associated output power is 5 dB lower than in the case of the optimal bias point. A first preliminary phase noise measurement shows a phase noise of less than –90 dBc/Hz at 1 MHz of the 180 GHz carrier.

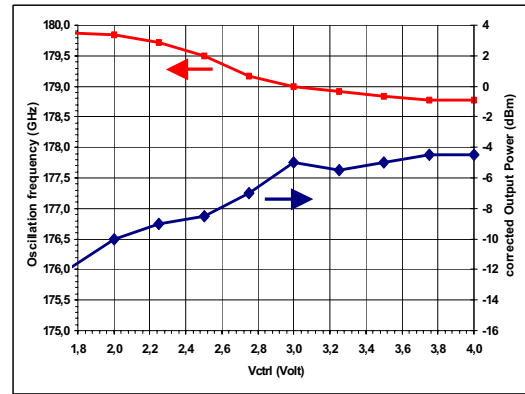

Fig. 5. Corrected output power and oscillation frequency vs current control pin (I_{ctrl}) at V_{EE}=-3.4V_{olt}.

Another push-push topology (similar to [4]) with 50-Ohm resistive load on the collector and the 2nd harmonic obtained at the virtual differential ground node at the end of the line resonator connected to the base is currently in measurement (see fig. 6).

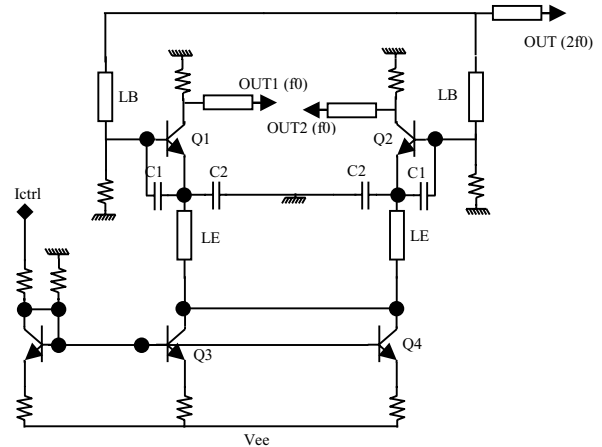

Fig. 6. Schematic diagram of the push-push oscillator (vco1).

Preliminary results show an oscillation frequency at 182 GHz and an associated output power of –12 dBm. With the same active device, we have reach 6 dB more output power in VCO3 (fig. 1) than VCO1 (Fig. 6) as expected and found in simulation. The measurement of VCO1 and phase noise of the two versions is under way and will be discussed during presentation.

V. CONCLUSION

In this paper, we have demonstrated, to the best of our knowledge, the highest frequency Si-based oscillator (20% higher than best reported in paper [4]).

The varactor integration in a new design and already demonstrated in [4], should be simplified by the fact there is a good agreement between simulation and results.

ACKNOWLEDGEMENT

We would like to thank Infineon Technology for fabricating these chips. This work is supported by the German ministry of education and research (BMBF) under the contract number 01M3139B. The authors are responsible for the content of this publication.

REFERENCES

- [1] A. Pavio and M. Smith, "A 20-40 GHz Push-Push Dielectric Resonator Oscillator," *IEEE Transactions on Microwave Theory and Techniques*, vol. 33, no. 12, pp. 1346-1349, December 1985.
- [2] F. Sinnesbichler, "SiGe HBT push-push oscillators for V-band operation," *2000 Meeting on Silicon Monolithic Integrated Circuits in RF Systems*, pp. 55-59, 2000.
- [3] Y. Baeyens et al, "Compact InP-based HBT VCOs with a wide tuning range at W- and D-band," *IEEE Transactions on Microwave Theory and Techniques*, vol. 48, no. 12, pp. 2403-2408, December 2000.
- [4] Y. Baeyens et al, "A monolithic integrated 150 GHz SiGe HBT Push-Push VCO with simultaneous differential V-band output," *IEEE Transactions on Microwave Theory and Techniques Symp. 2003*, pp. 877-880.
- [5] H. Li, H.M. Rein and M. Schwerd, "SiGe VCOs operating up to 88 GHz suited for automotive radar sensors," *Electronic Letters*, vol. 39, pp1326-1327, Sept. 2003.
- [6] J. Böck et al, "SiGe Bipolar Technology for automotive Radar Applications", *Proceedings of IEEE BCTM 2004*, Montreal, Canada, pp. 84-87.

