

S-BAND SSPA FOR MULTICARRIER APPLICATIONS

A. DARBANDI^{*}, E. ROGEAUX^{*}, M. ZOYO^{*}, B. RIVIERRE^{*}, L. LAPIERRE^{**}

^{*} Alcatel Espace BP 1187 26 avenue JF Champollion 31037 Toulouse

Phone: (33) + 5.34.35 57.60

e-mail : a.darbandi.alcatel@e-mail.com

^{**} CNES 18 avenue E. Belin 31055 Toulouse cedex

Phone: (33) + 5.61.27.41.34

FRANCE

ABSTRACT

A light weight, low distortion SSPA at S-band for multicarrier signal operation has been developed. The SSPA uses the MMIC chips for the low level amplification section and hybrid PHEMT devices for the medium level and high power level sections.

The SSPA exhibits at class A operation an output power of 3W, a noise power ratio (NPR) higher than 14dB with an associated PAE of 23% over the frequency band 2.16 - 2.20GHz.

INTRODUCTION

Highly linear power amplifiers are a vital requirement in multicarrier communications systems where the carrier signals have a highly time-varying envelopes. This special application requires a power amplifier with a reasonable degree of linearity [1].

PHEMT devices are becoming a very attractive choice for use in microwave power amplifiers due to specific characteristics such as high gain, linearity and high output power [2] [3].

In this paper, we present the results of a compact SSPA using the PHEMT devices achieving at S-band an output power of 3W in multicarrier signal, a noise power ratio (NPR) higher than 14dB with an associated Power Added Efficiency (PAE) of 23%.

SSPA DESIGN

The circuit topology is shown in figure 1.

The SSPA is composed of an MMIC attenuator (ATT), an MMIC amplifier (LLA), a medium level amplifier (MLA) with a 1mm gate width PHEMT chip device and a high power amplifier (HPA) with 2 times 16mm gate width PHEMT devices and an output isolator.

The medium and high power amplifiers were designed in hybrid technology in order to get the best PAE from the power devices.

The weight of the SSPA is less than 75 grammes.

PHEMT POWER MODULE DESIGN

Power modules are difficult to develop due to inadequacy measurements to characterize large periphery devices.

To overcome this problem, a comprehensive methodology is employed in this design using the scaling method [4]. A small cell of 1mm periphery is characterized with small-signal S parameters measurements and DC pulse tests. This measurements allow to extract the electrical parameters of linear and non-linear models. General rules of scaling are used in order to obtain the electrical model parameters of power PHEMT device used in the power module.

In this way, an hybrid power module is designed using two high power discrete 0.25 μ m PHEMT devices connected in parallel (a pair of 16mm gate widths from Sanders-Lockheed Martin Company).

Non-linear model of the PHEMT device is biased at class AB with Drain voltage of $V_{ds}=7$ volts and optimum loads at the fundamental and the second harmonic signal are determined from simulated load-pull method [5] [6].

Then, the matching networks of the power module are optimized by the harmonic balance simulator (Libra of HP-Eesof) to achieve the optimum combination of high output power and high PAE [7].

The input and output matching networks are designed on a high relative dielectric constant material ($\epsilon_r=38$). By using this type of material the volume of the hybrid module is significantly reduced compared to the use of the alumina substrate ($\epsilon_r=9.9$). The simulated AM/AM response of the power module for a single carrier ($V_{ds}=7V$, class AB) is shown in figure 2. The output power at 2dB gain compression is higher than 40 dBm, with the associated PAE greater than 67%.

The unconditional stability of the power module was checked by the K-factor method. The odd mode oscillations and the parasitic loops were checked by using the NDF method [8]. Figure 3 shows the real and the imaginary parts of the NDF factor over the frequency range from 0 to 50 GHz. The gain margin for the stability is greater than 22 dB from 0 to 21 GHz and greater than 18 dB from 21 GHz to 50 GHz, respectively.

EXPERIMENTAL RESULTS

The measured results of the power module under CW signal excitation in class A operation, at $V_{ds}=7V$ in given in figure 4. The output power at 2dB gain compression is higher than 40 dBm, with the associated power added efficiency of 52-56% over the required frequency band.

During the integration phase, we have observed oscillation phenomena when biasing the PHEMT devices at class AB operation. These parametric oscillations were generated during the switching on phase of the power module and were sustained even for the drain voltage of 7 Volts. The time domain analysis [9], using accurate non-linear model for the power devices can demonstrate the stability of the power module during and after the switching on operation.

This undesirable oscillation was suppressed by modifying the gate biasing network of the power module as following:

- adding a small resistor,
- changing the type and the value of decoupling capacitors,
- operating the PHEMT devices in class A.

These modifications have decreased the output power and the PAE of the module. The Microwave Spice simulator has been used to analyse the time domain response of the devices under a step DC voltage.

Figure 5 presents the time domain response of the devices under a pulsed DC voltage. The drain current of PHEMT devices reach the steady state in less than 2 micro-seconds.

The large band gain response of the SSPA with 5 dB of attenuation is show in figure 6. The SSPA presents an in-band (2.16 - 2.2 GHz) linear gain of 63 dB (with 0 dB of attenuation), with a satisfactory out of band gain response.

Figure 7 gives the measured results of the SSPA under multicarrier signal excitation. This SSPA exhibits an output power higher than 4W, 63dB of linear power gain with an associated PAE higher than 32%, at 2.18GHz for NPR of 12dB. Good linearity, measured as NPR higher than 14dB is achieved for output power of 3W with PAE greater than 23%.

It is estimated that the PAE of the SSPA can reach up to 40% (for NPR = 14dB) by stabilizing the PHEMT devices at class AB operation using the Microwave Spice simulator.

CONCLUSION

The use of MMIC chips, power PHEMT devices and hybrid technology allow to achieve the best output power and PAE with good linearity and to minimize the weight and the size of the SSPA.

Using the comprehensive methodology developed by Alcatel Espace, linear and non-linear electrical models of PHEMT chip devices were established. This work has allowed us to design a power module and to develop a SSPA at S-band for a multicarrier application. The next step is to analyse the time domain behaviour of power PHEMT devices under class AB operation in order to increase the linearity and the PAE of the SSPA.

ACKNOWLEDGMENTS

The authors would like to thank J. Barriento and H. Yahi for their work in tuning and testing the SSPA.

This work has been supported by the CNES agency through the GPAD bande S contract. The authors would also like to acknowledge the CNES agency for its support.

REFERENCES

- [1] A. PLATZKER, S. BOUTHILLETTE: "Variable output, high efficiency - low distortion S-band power amplifiers and their performances under single tone and noise power excitations" IEEE MTT-S Digest, 1995, pp441-444
- [2] J.J. KOMIAK, S.C. WANG, T.J. ROGERS: "High Efficiency 11Watt Octave S/C-Band PHEMT MMIC Power Amplifier" IEEE MTT-S Digest, 1997, pp1421-1424
- [3] M.J. SCHNIDER: "GaAs Power PHEMT Technology and its Applications" Asia Pacific Microwave Conference, 1996, pp231-234
- [4] V.I. COJOCARU, T.J. BRAZIL: "Scaleability of DC/AC non-linear dispersion models for microwave FETs" IEEE MTT-S Digest, 1997, pp387-390
- [5] D.M. SNIDER: "A theoretical analysis and experimental confirmation of the optimally loaded and overdriven RF power amplifier" IEEE Trans. on El. Devices Vol.14 n°12, Dec. 1967, pp851-857
- [6] J-H. LEE, S-I. YANG: "The effects of the second and third harmonic loading on the power-added efficiency of power amplifiers" Asia Pacific Microwave Conference Oct. 1995, pp197-200
- [7] M. ZOYO, C. GALY, A. DARBANDI, L. LAPIERRE, J.F. SAUTEREAU: "Amplificateurs de puissance hybrides à haut rendement" 10èmes J.N.M. Paris Mai 1997 pp402-403
- [8] A. PLATZKER, W. Struble, K. Hetzler: "Instabilities Diagnostics and the Role of K in Microwave Circuits " IEEE MTT-S Digest, 1993, pp1185-1188
- [9] D. Teeter: "Practical consideration for Developing High Efficiency Power Amplifiers" High Power MMIC Amplifier Workshop IEEE MTT-S Digest, 1998

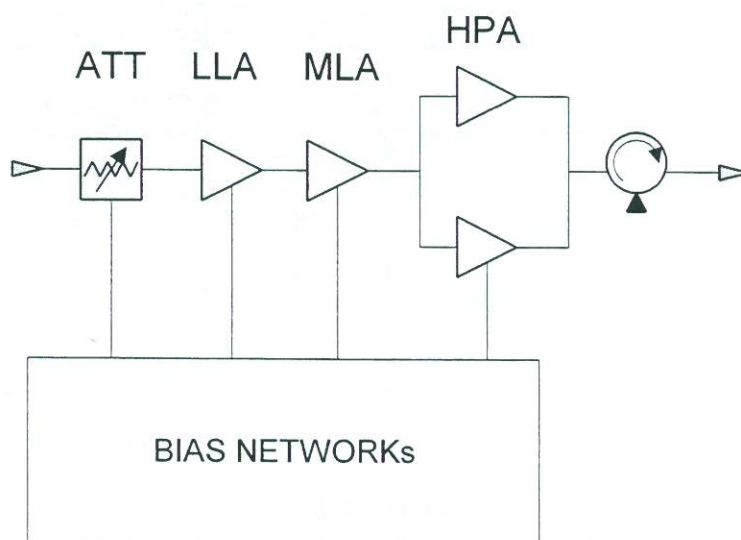

**FIGURE 1:
TOPOLOGY OF THE SSPA**

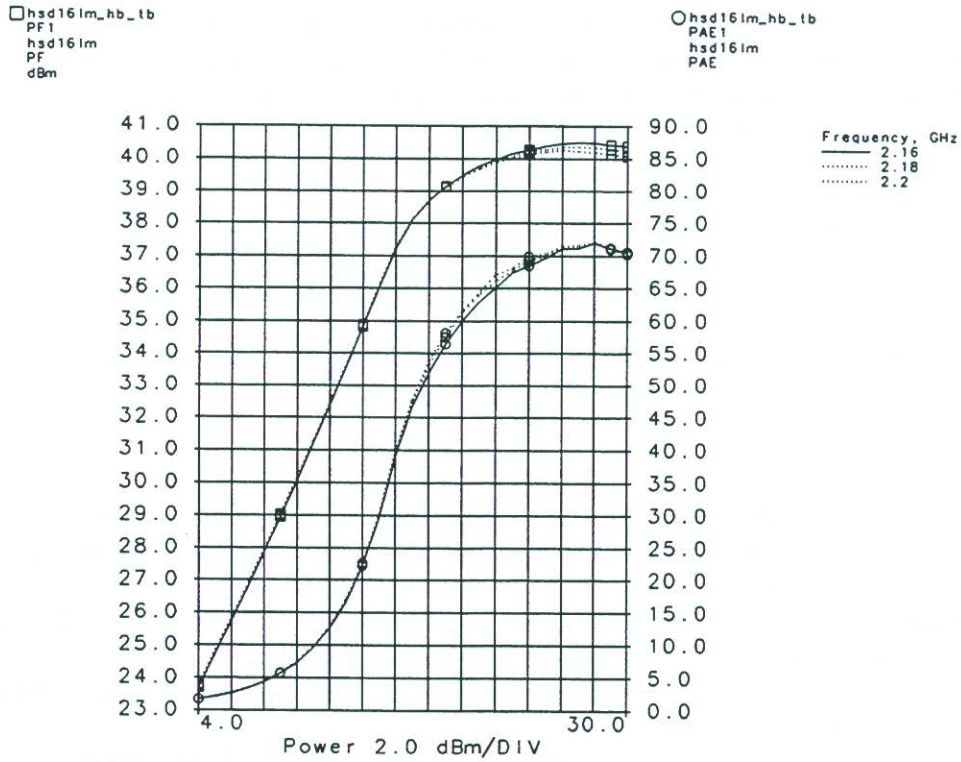

FIGURE 2:
SIMULATED RESULTS OF THE POWER MODULE FOR CW SIGNAL
(P_o , PAE AS A FUNCTION OF P_{in})

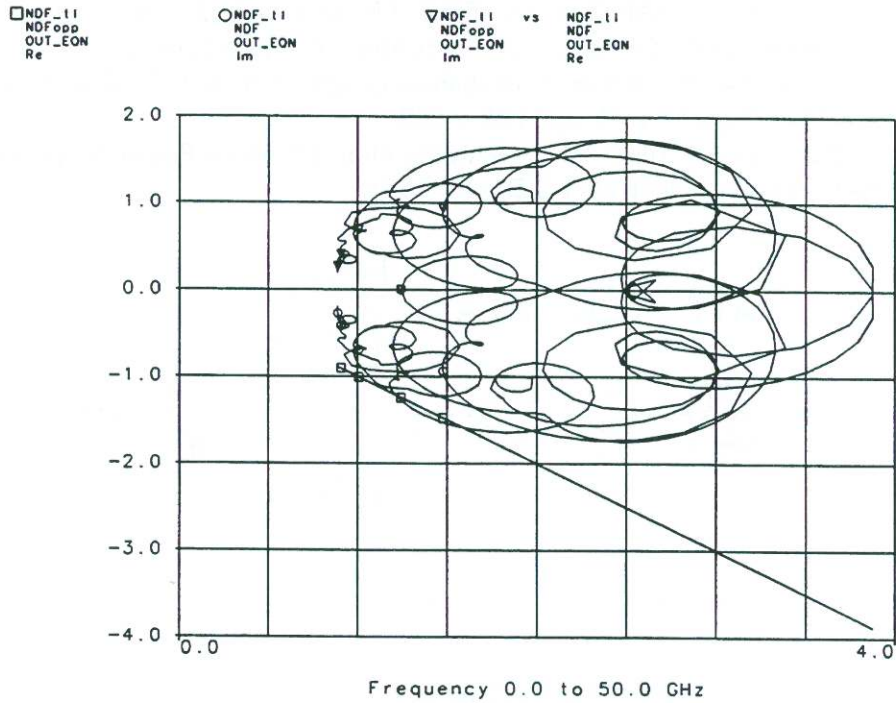

FIGURE 3
STABILITY RESPONSE (NDF) OF THE POWER MODULE

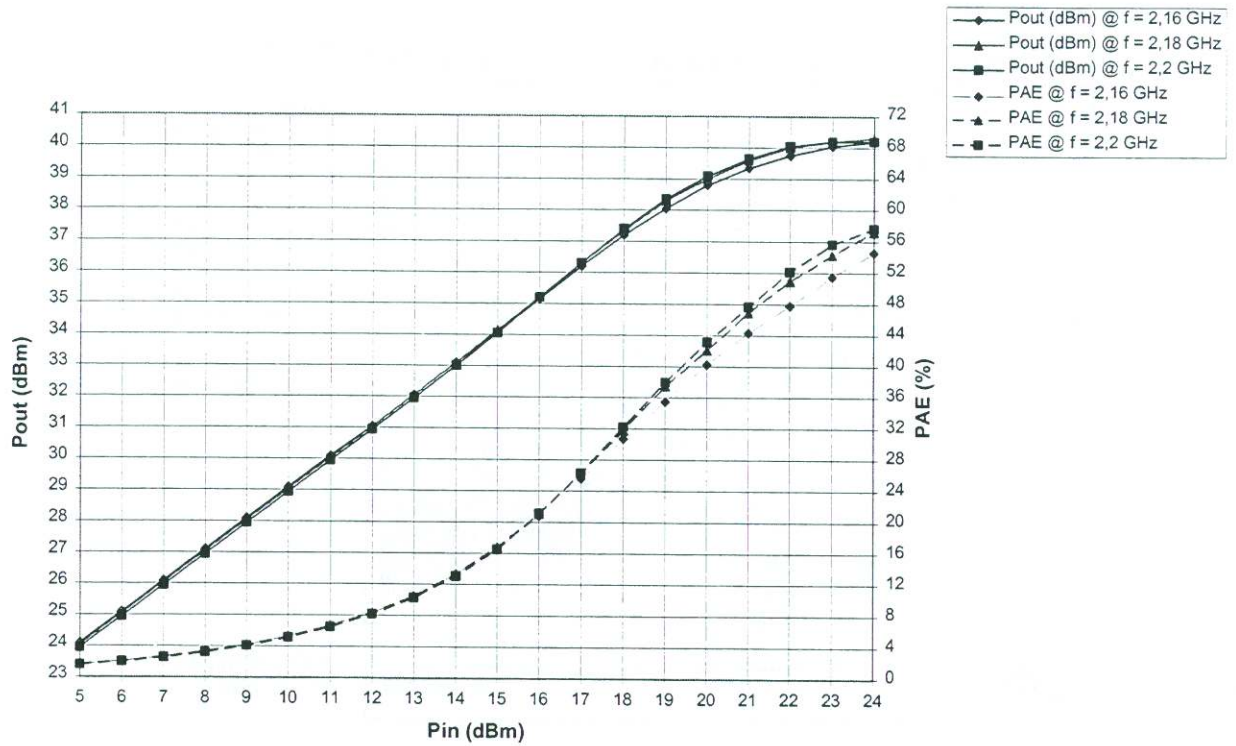

FIGURE 4:
MEASURED RESULTS OF THE POWER MODULE IN CW SIGNAL
(P_o , PAE AS A FUNCTION OF P_{in})

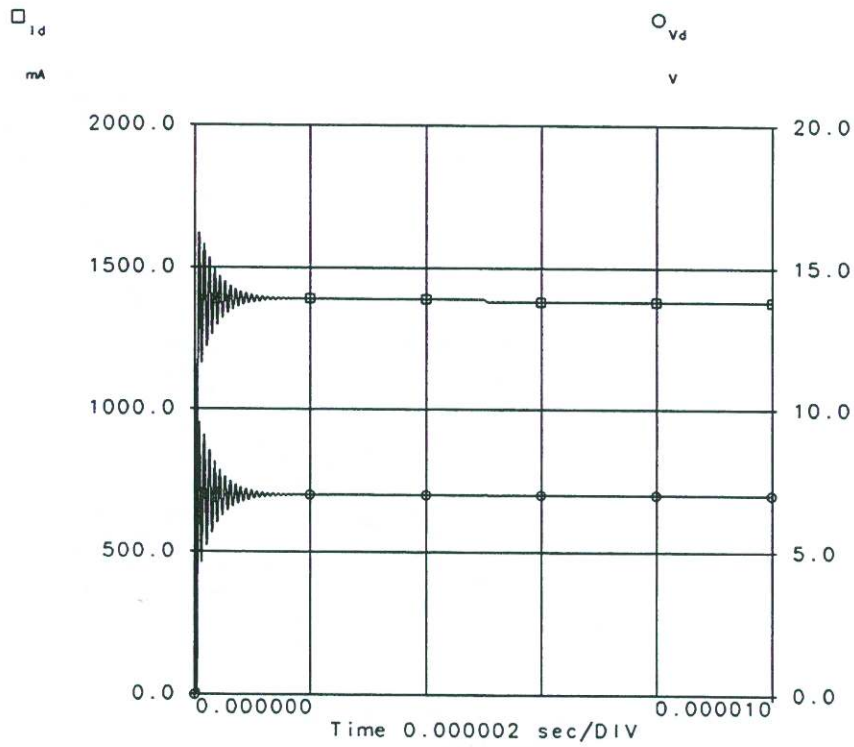
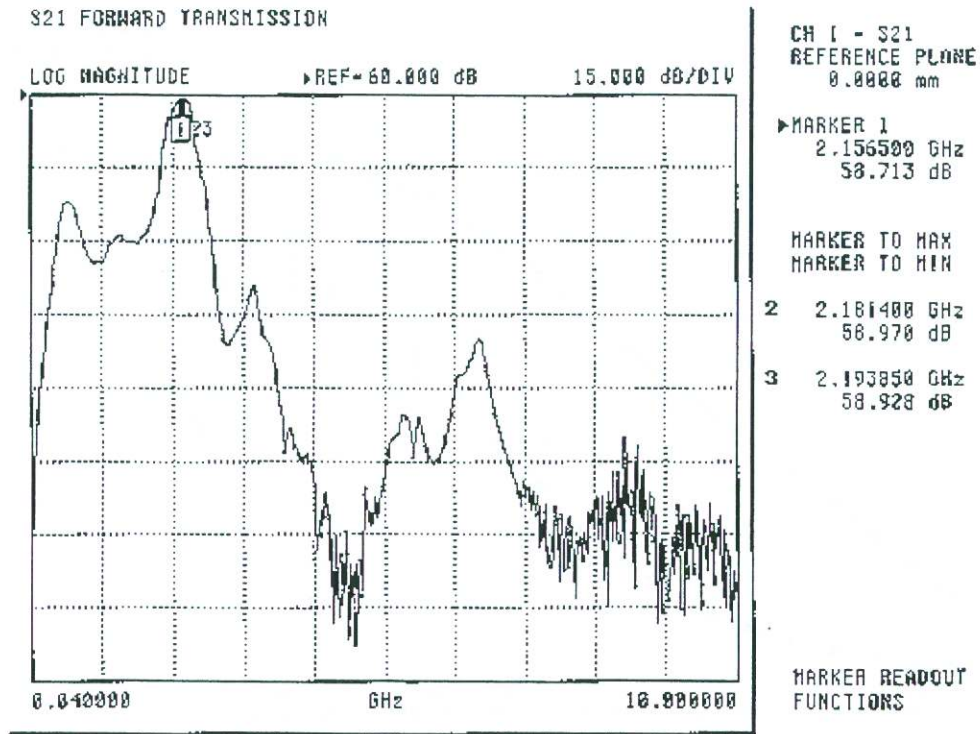
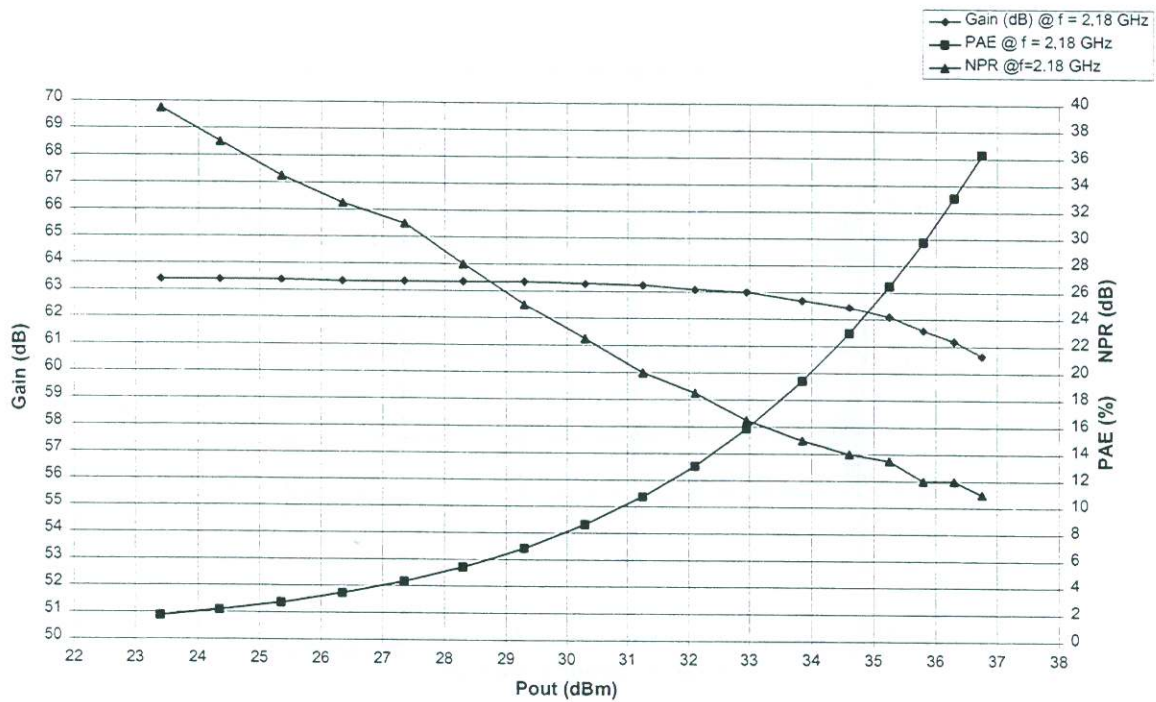

FIGURE 5
TIME DOMAIN RESPONSE OF THE POWER MODULE
(V_{ds} , I_{ds})



**FIGURE 6:
MEASURED GAIN RESPONSE OF THE SSPA**



**FIGURE 7:
MEASURED RESULTS OF THE SSPA IN MULTICARRIER SIGNAL**