

ERNESTO D'ALBERGO
FULL PROFESSOR IN THE SCIENCE OF FINANCE

ECONOMY
OF
PUBLIC FINANCE

UNIVERSITY LESSONS OF
SCIENCE OF FINANCE



Domenico da Empoli
PRESENTATION OF E. D'A.

Nino Luciani
THE SCIENTIFIC WORK OF E. D'A.:
INTRODUCTION

BOLOGNA UNIVERSITY, DIGITAL EDITION, 2014
English translation of the Italian Edition, 1952
For English and Italian editions, see: <http://amsacta.unibo.it/2571/>

- ORIGINAL TITLE: Economia della Finanza Pubblica.

The original 1952 printed edition is available at the University Library in Bologna and at the Library of "La Sapienza" University in Rome (Faculty of Political Science, first floor). It should also be available at libraries in other Italian universities.

- Translation from italian by Franca Simpson.

BA Cert Acct (Open) DipTrans(IoLET) MCIL MITI TA

E-mail: francasimpson@gmail.com .

- English Edition by Nino Luciani

E-mail: nino.luciani@alice.it

NOTE. This English translation was funded by Maria d'Albergo, d'Albergo's niece and daughter of Raphael, his eldest brother.

CONTENTS

DOMENICO DA EMPOLI, PRESENTATION OF E. D'ALBERGO, 8
NINO LUCIANI, INTRODUCTION TO THE SCIENTIFIC WORK OF E. D'ALBERGO, 11

INTRODUCTION, 35

- I.- DEFINITION OF THE SCIENCE OF FINANCE AS ECONOMY OF PUBLIC FINANCE, **35**
- II.- SCIENTIFIC TREATISE FOR THE PURPOSE OF KNOWLEDGE ACCORDING TO THE DEFINITION, **36**
- III.- THEORETICAL PRINCIPLES GUIDING RESEARCH, **36**
- IV.- EXPLICIT RATIONAL AND QUANTITATIVE CONCEPT IN THE DEFINITION AND “VALUE JUDGMENTS” , **38**
- V.- RATIONALE OF THE DEFINITION STATING THE LIMITATION OF THEORETICAL RESEARCH WITH RESPECT TO ECONOMIC ISSUES OF THE PROBLEMS OF PUBLIC FINANCE, **41**
- VI.- RELATIONSHIP BETWEEN LAW AND ACTUAL PHENOMENON (POSITIVE SYSTEM) , **59**
- VII.- THE DOMAIN OF HYPOTHETICAL ABSTRACTION IN PUBLIC FINANCE ECONOMICS, **54**
- VIII.- AUTONOMY OF THE SCIENCE OF PUBLIC FINANCE FROM POLITICAL ECONOMICS, **62**
- IX.- LIMITATIONS OF THE DEMONSTRATED RELATIVE AUTONOMY OF THE “SCIENCE OF FINANCE” FROM “POLITICAL ECONOMY”. HYPOTHESIS OF QUANTITATIVE EQUIVALENCE BETWEEN FISCAL CONSTRAINT AND OTHER RELATIONSHIPS AMONG ECONOMIC FACTORS ALSO IN “MASS PHENOMENA” , **76**
- X.- RELATIONSHIP BETWEEN FINANCIAL ECONOMICS AND: A) ECONOMIC AND FINANCIAL POLICY IN THE TRADITIONAL SENSE; AND B) “FISCAL POLICY” IN THE KEYNESIAN SENSE, **80**
- XI.- THE RATIONAL CHARACTER OF THE STUDY CARRIED OUT IN THESE LESSONS OF PUBLIC FINANCE ECONOMY, **93**

CHAPTER I. - PUBLIC NEEDS – PUBLIC EXPENDITURES, 108

- I.- PUBLIC NEEDS, **38**
- II.- PUBLIC EXPENDITURES, **115**
- III.- DECISION CRITERION OF THE EXTENT OF PUBLIC NEEDS TO BE MET: “PARETO’S SECOND CRITERION” , **118**

CHAPTER II. - PUBLIC REVENUES, 124

- I.- THE LOGIC OF THE SEQUENCE: PUBLIC NEEDS – PUBLIC EXPENDITURES – PUBLIC REVENUES, **124**
- II.- PUBLIC REVENUES FROM THE POINT OF VIEW OF THE MEMBERS OF THE COMMUNITY WHO DEMAND OR EXPERIENCE THE CONSUMPTION OF PUBLIC SERVICES, **127**
- III.- PUBLIC REVENUES FROM THE POINT OF VIEW OF THE STATE THAT: I) OFFERS AND II) IMPOSES CONSUMPTION OF SERVICES, **137**
 - A) PRIVATE OR QUASI-PRIVATE PRICE, **137**
 - B) PUBLIC PRICE, **138**
 - C) TAX (AS NON-COERCIVE PAYMENT) , **143**

- D) MIXTURE OF NON-FISCAL TAXES AND TAXES WITH THE NATURE OF TRIBUTES, **144**
- E) CONTRIBUTIONS (OF SPECIFIC BETTERMENT) , **145**
- F) GENERAL TAXES. , **148**
- IV.- GENERAL TAXES AND THEIR CLASSIFICATION, **150**
 - A) DIRECT AND INDIRECT TAXES. , **151**
 - B) REAL AND PERSONAL TAXES, **152**
 - C) PROPORTIONAL AND PROGRESSIVE TAXES, **153**

CHAPTER III. - ABOUT THE SUBJECTIVE DISTRIBUTION CRITERIA (“MODES”) OF THE COST OF INDIVISIBLE PUBLIC SERVICES, 154

- I.- HYPOTHETICAL SWITCHING OF THE SUBJECT OF HEDONISTIC EVALUATIONS FROM SINGLE MEMBERS OF THE COMMUNITY TO THE GOVERNING CLASS OF THE SAME COMMUNITY, **154**
- II.- INTUITIONS AND SCIENTIFIC DEMONSTRATIONS IN THE CONTEXT OF PRINCIPLES AND CRITERIA OR “MODES” OF DISTRIBUTION OF THE COST OF INDIVISIBLE PUBLIC SERVICES, **159**
- III.- FURTHER METHODOLOGICAL WARNINGS FOR A RATIONAL VIEW OF THE PROBLEM, **165**
- IV.- LOGICAL LEGITIMACY AND THEORETICAL INVENTIVENESS OF THE HYPOTHESIS OF A “TYPICAL” DECREASE IN THE MARGINAL UTILITY OF INCOME FROM THE POINT OF VIEW OF THE GOVERNING CLASS ON BEHALF OF MEMBERS OF THE COMMUNITY, **169**
- V.- IRRATIONAL AND CONTRADICTORY SCEPTICISM LINKED TO THE DENIAL OF A “TYPICAL” DECREASE OF MARGINAL UTILITY OF INCOME, LOGICALLY ASSUMED AS RATIONAL HYPOTHESIS IN THIS COURSE, **175**
- VI.- ANALYSIS OF THE PRINCIPLES OF SACRIFICE: A) EQUAL, B) PROPORTIONAL, C) COLLECTIVE MINIMUM, **179**
- VII.- CONSIDERATIONS OF FINANCIAL POLICY AND STATISTICS INFLUENCING THE QUANTITATIVE DETERMINATION AND THE INTRODUCTION OF PROGRESSIVE TAX. PROGRESSIVE SYSTEMS. , **193**
- VIII.- CRITICISM OF THE “FUNDAMENTAL” PROPERTY OF PROGRESSION AND ITS RELATIVITY , **197**

CHAPTER IV. - ABOUT THE PRINCIPLE OF “CONTRIBUTIVE CAPACITY” , 205

- I.- ATTEMPTS TO GIVE MEANING TO THE CONCEPT OF CONTRIBUTIVE CAPACITY IN OBJECTIVE TERMS: CONTRIBUTIVE CAPACITY RELATIVE TO THE BENEFITS (EFFECTS) OF PUBLIC EXPENDITURE, **205**
- II.- DIFFERENTIAL TAXATION OR ELISION OF “PROTECTION INCOMES” IN THE LIGHT OF THE “PRINCIPLE OF RELATIVE CONTRIBUTIVE CAPACITY” , **210**

CHAPTER V. - ABOUT SO-CALLED “ECONOMIC”, “NEUTRALITY”, “PRODUCTIVISTIC” PRINCIPLES AND OTHER CRITERIA FOR THE DISTRIBUTION OF GENERAL TAXES, 221

- I.- ENRICO BARONE’S “ECONOMIC PRINCIPLE” , **221**
- II. THE NEUTRALITY OF THE IMPOSITION IN RELATION TO THE DISTRIBUTION OF INCOMES DALTON’S FORMULATION, **226**
- III.- THE “PRODUCTIVISTIC PRINCIPLE” , **229**
- IV.- THE SO-CALLED CRITERION OF EXPEDIENCY, **232**

CHAPTER VI. - QUALITATIVE DIFFERENTIATION OF TAXABLE INCOMES, 234

- I.- REASONS THAT DICTATE THAT THE STUDY OF DIFFERENTIATION OF TAXABLE INCOMES COMES BEFORE THE PURGE OF THE OBJECT OF THE IMPOSITION, **234**
 - II.- POLITICAL AND SOCIOLOGICAL EXPLANATIONS OF QUALITATIVE DIFFERENTIATION, **235**
 - III.- DIFFERENTIATION EXAMINED, **237**
 - IV.- THE TWO THEORETICAL APPROACHES OF THE PROBLEM: A) ONE OF OBJECTIVE OR RICARDIAN TYPE; B) THE OTHER, APPROPRIATE AND RATIONAL, OF MARGINALISTIC OR SUBJECTIVE TYPE, IN THE MEANING THAT WILL BE SPECIFIED, **237**
 - V. DEMONSTRATION OF THE QUALITATIVE DIFFERENTIATION ON HEDONISTIC BASIS (FIRST APPROXIMATION) , **245**
 - VI.- FURTHER DEDUCTIONS AND WARNINGS ON DIFFERENTIATION, **247**
 - VII.- SECOND APPROXIMATION ANALYSIS FOR THE EXPLANATION OF QUALITATIVE DIFFERENTIATION, **249**
 - VIII.- THE “FUNCTION OF CONSUMPTION” IS INTRODUCED IN THE REASONING, **251**
- APPENDIX, 254**

CHAPTER VII. - ABOUT THE “DOUBLE TAXATION OF SAVINGS” , 260

- I.- THE SOLUTION TO THE PROBLEM OF EQUAL TAXATION IS IMPLICIT IN THE HYPOTHETICAL DEFINITION OF THE TAXABLE OBJECT, **260**
- II.- HETEROGENEITY OF THE TWO SYSTEMS OF TAXATION: A) OF CONSUMED INCOME, B) OF PRODUCED INCOME. , **269**

CHAPTER VIII. - THE PROCESS OF “PURGING” OF ECONOMIC QUANTITIES FOR THEIR REDUCTION TO TAXABLE QUANTITIES, 275

- I.- THE PURGING OF TAXABLE QUANTITIES IN THE HYPOTHESIS OF TAXATION OF INCOME: 1) THE PRODUCT, 2) TOTAL AVAILABLE INCOME, 3) CONSUMED INCOME, OR FROM ASSETS , **275**
 - II.- LOGICAL FOUNDATION OF THE PURGING PROCESS OF TAXABLE OBJECTS , **277**
 - III.- REASONS OF RATIONAL ECONOMIC ORDER THAT GIVE RISE TO TAXATION OF “NET” RATHER THAN “GROSS” INCOMES , **278**
- APPENDIX, 282**

CHAPTER IX. - THE ECONOMIC EFFECTS OF TAXES, 284

- I.- IMPORTANCE AND PLACEMENT OF THIS STUDY AS A CHAPTER ON PUBLIC FINANCE, **284**
- II.- THE PRINCIPLE OF CAUSALITY AND FINALITY AND THE ATOMISTIC APPROACH TO THE PROBLEM OF THE ECONOMIC EFFECTS OF TAXES; THE DETERMINISTIC PRINCIPLE AND THE APPROACH TO THE PROBLEM ACCORDING TO THE GENERAL ECONOMIC EQUILIBRIUM , **293**
- III.- LOGICAL NECESSITY OF THE SIMULTANEOUS OR COORDINATED STUDY OF THE EFFECTS OF COLLECTION AND EXPENDITURE OF TAXES, **300**
- IV.- COMPARISON OF THE TWO MODELS IN QUANTITATIVE TERMS, **306**
- V.- EXPLANATION OF THE CURRENT SIMPLIFICATIONS OF THE STUDY OF THE EFFECTS OF TAXES, **310**

CHAPTER X. - ANALYSIS OF THE EFFECTS OF FINANCIAL ACTIVITY, 313

- I.- HISTORICAL AND LOGICAL NEED TO GIVE PRIORITY TO THE CONDITION OF “PURE” OR “PERFECT” COMPETITION , **313**
- II.- TRANSFER IN CONDITIONS OF PERFECT COMPETITION, ELASTIC DEMAND AND INCREASING COSTS, **317**
- III.- SHIFTING AND DECREASING COSTS, **321**
- IV.- SHIFTING IN CONDITIONS OF PURE AND TOTAL MONOPOLY, **326**
- V.- SHIFTING IN CONDITIONS OF PARTIAL MONOPOLY, **340**
- VI.- SHIFTING IN CONDITIONS OF MONOPOLISTIC COMPETITION, **343**
- VII.- THE HYPOTHESIS OF BILATERAL MONOPOLY AND SHIFTING, **347**
- VIII.- REGRESSIVE SHIFTING, **350**
- IX.- EFFECTS OF THE IMPOSITION AND CONSUMER’S SURPLUS, **354**
- X.- EFFECTS OF THE TAX ON QUANTITIES IN THE CASE OF: COMPLEMENTARY GOODS; B) SUCCEDANEOUS GOODS , **361**
 - A) SHIFTING OF THE TAX IN THE CASE OF COMPLEMENTARY GOODS , **362**
 - B) SHIFTING OF THE TAX IN THE CASE OF SUCCEDANEOUS GOODS. , **364**
- XI.- COINCIDENCE OF PERCUSSION AND INCIDENCE: THE AMORTIZATION OF THE TAX, **367**
- XII - SUPPRESSION OF THE TAX, **369**
 - A) HYPOTHESIS OF FIXED TAX, **370**
 - B) HYPOTHESES OF TAX PROPORTIONAL TO INCOME, **371**

CHAPTER XI. - OTHER PROBLEMS RELATING TO THE SHIFTING OF THE ECONOMIC AND HEDONISTIC COMPARATIVE EFFECTS OF TRIBUTES, 373

- I.- FISCAL DUTIES, **373**
- II.- SPECIAL EFFECTS OF THE TAX ON ALL EXCHANGES, **376**
- III.- MANUFACTURING TAXES, FISCAL MONOPOLIES AND THEIR ALTERNATIVES, **381**
- IV.- COMPARATIVE BURDEN OF DIRECT AND INDIRECT TAXES, AT EQUAL COLLECTION LEVELS , **386**
- V.- RELATIONSHIPS BETWEEN THE PREVIOUS THEORY AND VISIONS OF MAXIMUM COLLECTIVE WELFARE (HOTELLING) , **392**
- VI.- THE “ECONOMIC PRINCIPLE” AND THE INTEGRATION OF DIRECT AND INDIRECT TAXES, **397**
- VII.- MULTI-DIRECTIONALITY OF DEMAND AND THE THEORY OF TAXES ON CONSUMPTION, **399**

CHAPTER XII. - EFFECTS OF TAX “RELIEFS” , 416

- I.- THE IRREVERSIBILITY OF MODIFICATIONS CAUSED BY “FACTUM PRINCIPIS” ON THE CONDITIONS OF GENERAL ECONOMIC EQUILIBRIUM, **416**
- II.- EFFECTS OF THE “RELIEF” FROM GENERAL AND PROPORTIONAL TAXES ON INCOME, **417**
- III.- EFFECTS OF THE “RELIEF” OF NON-GENERAL TAXES, **419**

CHAPTER XIII. - DEDUCTIVE THINKING AND QUANTITATIVE MEASUREMENT OF ECONOMIC EFFECTS OF TAXES, 421

- I.- LOGICAL UNRELIABILITY OF THE STATISTICAL DETERMINATION OF THE EXTENT OF VARIATIONS DUE TO TAX, **421**

II.- LIMITATIONS OF THE MEANING OF EMPIRICAL-STATISTICAL STUDIES FOR THE MEASUREMENT OF THE EFFECTS OF TAXES, **423**

CHAPTER XIV. - EFFECTS OF ECONOMIC FLUCTUATIONS ON REVENUE FROM TAXES, 426

I.- THE "PASSIVE ELASTICITY OR SENSITIVITY" OF REVENUE FROM TAXES TO THE VARIATIONS OF THE GENERAL ECONOMIC SITUATION, **426**

II.- THE PROBLEM OF NEUTRALIZATION OF THE ECONOMIC SENSITIVITY OF TAXES, **433**

APPENDIX , 436

CHAPTER XV. - THEORY I) OF THE TRIBUTARY AND FISCAL BURDEN AND II) OF THE EFFECTS OF PUBLIC EXPENDITURE , 439

I.- THE THEORY IN THE HYPOTHETICAL CONTEXT OF A STATE: , **439**

I) ANALYSIS OF THE TERMS OF THE RELATIONSHIPS USED TO EXPRESS THE CONCEPTS OF "TRIBUTARY" AND "FISCAL" BURDEN, **439**

II) THE FUNCTIONAL DEPENDENCE OF THE NATIONAL REVENUE FROM THE MANAGEMENT OF MONETARY QUANTITIES COLLECTED AND SPENT BY THE GOVERNING CLASS FOR THE STATE , **444**

III) FISCAL BURDEN IN SUBJECTIVE TERMS OF HEDONISTIC UTILITIES AND SACRIFICES, **449**

II.- TRIBUTARY BURDEN IN INTERNATIONAL COMPARISONS, **452**

CHAPTER XVI. - SOME PROBLEMS OF EXTRAORDINARY FINANCE, 456

I.- RATIONALITY OF THE LOGICAL AND METHODOLOGY APPROACH TO PROBLEMS OF EXTRAORDINARY FINANCE, DIFFERENTIATED IN TERMS OF DEGREE, ACCORDING TO THE QUANTITATIVE ASPECT, FROM THOSE OF ORDINARY FINANCE, **456**

II.- THE INSTRUMENTS OF EXTRAORDINARY FINANCE – THE HISTORICAL RELATIVITY OF THEIR USE AS A SOLUTION TO THE CORRESPONDING REAL FINANCIAL PROBLEM AND SPATIAL-TEMPORAL EMPIRICAL UNIFORMITIES, **463**

A) WAR TREASURY, **463**

B) AND C) EXTRAORDINARY TAX AND PUBLIC LOANS, **464**

III.- THE PROBLEM OF COMPARATIVE BURDEN OF LOANS AND OF THE EXTRAORDINARY TAX IN PURE (DEDUCTIVE) THEORY, **472**

IV.- EXTRAORDINARY TAX ON PROFITS FROM SPECIAL ECONOMIC SITUATIONS, **423**

V.- VARIOUS TYPES OF PUBLIC LOANS SECURITIES, **490**

VI.- THE CONVERSION OF PUBLIC LOANS, **492**

VII. THE AMORTIZATION OF PUBLIC DEBT, **492**

VIII.- THE PROBLEM OF THE "LIMITS" OF PUBLIC DEBT, **497**

IX.- "THE CIRCUIT OF CAPITAL" FOR THE FINANCING OF WAR WITHOUT INFLATION, **500**

ERNESTO D'ALBERGO - BIBLIOGRAPHY, 506

DOMENICO DA EMPOLI*

Ernesto d'Albergo – Presentation

1. Ernesto d'Albergo was one of the most representative Italian academics in the field of the science of finance of the last century.

The time in which d'Albergo studied and composed his contributions was a period in which Italian economic studies (and those in the science of finance in particular) enjoyed wide international recognition. Even though it is not entirely appropriate to speak of a real Italian science of finance “school” because of the variety and the diversity of methodological positions and points of views among the various scholars in this discipline, there is no doubt that many of the issues that are still today central to the study of the science of finance were identified by Italian scholars. Their solutions, even though they are based on theoretical models less sophisticated than those used today, were essentially correct and very innovative for their time.

We need only consider the theory of public goods, which represents the theoretical core around which the science of finance (as in terms of “supply and demand of public goods”) has developed, in parallel with political economy (“supply and demand of private goods”) and which, in the context of the determination of partial equilibriums, was studied in depth in an exemplary manner by Antonio De Viti De Marco (preceded by Maffeo Pantaleoni and alongside Ugo Mazzola). This is furthermore apparent when we consider the numerous contributions to the theory of the tax shifting and the effects of public debt, in addition to more specific contributions, such as “Barone’s theory” on the excess of burden of indirect taxes and the debates on the double taxation of savings.

The first studies of economic analysis of institutions, which have been initiated with De Viti’s distinction between the “monopolist” State and the “cooperative” State and the politico-sociological models that have contributed to outlining the bases of a real “theory of the supply” of public goods, should also not be overlooked.

Ernesto d'Albergo operated in this ample investigation field and manifested an innovative ability, by considering in depth and with an original vision themes already addressed by other scholars and by widening the field of investigation to new subjects, or to subjects not previously sufficiently examined, such as the crisis of the personal income tax, issues relating to the economic sensitivity of levies and even a preview of modern budget economy. He also presented new interpretations of widely debated theories, such as Puviani’s theory of financial illusions, of which he demonstrated the applicable extension also to democratic institutional contexts.

Alongside themes of theoretical character, d'Albergo also considered, at different times, concrete aspects of the tax system, in particular in the first post-war period and later, in the 1960s, on occasions of the debates preceding the Italian tax reform.

Ernesto d'Albergo dedicated much attention to current economic and financial problems, both in Italy and abroad, with essays published in scientific papers (in particular the *Rivista Bancaria* [*Banking Review*], Minerva Bancaria, edited by him from 1945) and also in economic newspapers (in particular *Il Sole-24 Ore*).

2 E. d'Albergo’s “scientific project” was founded on the “research of theoretical uniformities relative to analysis:

a) of the methods by which the State and minor governments are able, with or without compulsion, to generate revenue and fund the necessary expenditure to meet public needs;

* Full Professor of Science of Finance at the “La Sapienza” University of Rome.

b) of the variations of specific equilibriums and of the more general economic balance caused by the methods and extent of collections and, generally, raising revenues and the distribution of expenses, in the various market organisation hypotheses and the impact, or otherwise, of the time variable" (*Economia della Finanza Pubblica [Public Finance Economy]*, Vol. I, p. 4).

Nino Luciani, as pupil and therefore as "true" interpreter of d'Albergo's thought, offers a general introduction to his position on the central theme of the Paretian optimality, and in particular of the logic with which d'Albergo accepted the Paretian principle of the "maximum collective utility", which he defined as "The second Paretian criterion". The implications of this choice with regard to his theory of public goods arise from his analysis, in contrast with that of Samuelson, as well as from Pigou's concepts of welfare economics.

Other aspects of d'Albergo's work are identified in Luciani's introduction, such as his forerunning vision of Keynesian economic policy, his applications of the concept of contributive capacity, the studies on the effects of levies in a collectivistic regime and furthermore more specific but no less interesting issues, such as the amortisation of public debt, the double taxation of savings and the effects of taxes on international exchanges.

3. From his *Economia della Finanza Pubblica [Public Finance Economy]* emerges the personality of a scholar who is also independent from the Italian tradition, of which he nevertheless considered himself to be part and also almost custodian of (perhaps we should refer to him as "its paladin").

Born at a time when national scientific traditions had their own identity because of the limited circulation of ideas in the international scientific world, and in which the Italian scientific tradition in the field of public finance had a significant presence (even if many of the Italian contributors had been almost neglected, as the success of the essay by James M. Buchanan on the science of finance demonstrated), d'Albergo did not adapt well to the new situation, progressively established after the Second World War, in which the internationalisation of the economic science had led to the marginalisation of the so-called Italian school of the science of finance.

If we do not take into consideration this particular, almost resentful, attitude of d'Albergo, it is not possible to understand the confrontations in his late years with American scholars, whose reformulation of Italian theories was for him the cause of destructive interventions rather than of the peaceful debate which might have been contributed to the reframing of Italian contributions in the international scientific community, which d'Albergo himself aspired to.

For example, I believe that Paul Samuelson's essays on the theory of public goods have been, both in terms of their specific content and for the scientific role of Samuelson himself, very important in the re-evaluation of studies in the science of finance, at a time when macroeconomic investigations seemed to be prevalent. I believe that there are no doubts that the renewed international attention to the science of finance, which has not wavered since, has been to a large extent due to them.

However Samuelson had "looked down" on Italian theories, which was rather short-sighted of him, in part because the American economist did not have a direct knowledge of Italian contributions: his considerations were based on a rather poor summary supplied to him by Richard Musgrave (as he himself admitted some years ago) who had, furthermore, produced it without direct knowledge of the Italian sources.

At the same time, d'Albergo's attitude of complete denial with regard to the work of James Buchanan remains unexplained.

In any case, I believe that Buchanan's long essay on Italian financial theory represents to this day the main international reference for those who want to study the Italian contributions to the science of finance.

Further essays by Buchanan, and in particular the constructions of Public Choice theory, which have established a permanent link with the Italian tradition, have represented an essential recognition of Italian financial science.

All this takes nothing away from Ernesto d'Albergo's own scientific merit, to which this book, here translated into English, is testament, even if an incomplete one, as it needs to be remembered that d'Albergo had added some "Revisions" to this (in the 1971 edition), which Luciani was not able to include here due to the objective difficulty of linking them in a rigorous manner to the themes covered by the book here translated into English.

NINO LUCIANI*

*Introduction to the scientific work of
Ernesto d'Albergo*

SUMMARY. *1.- Foreword. The man and the Master. 2.- Separation of science of finance from financial law. Relationship between science of finance and political economy. 3.- The governing class as “single subject” in public choices; a) Differentiation between Pareto’s first criterion and second criterion; b) Pareto’s second criterion; c) Relationship between Pareto’s second criterion and the “second theorem of welfare economy”. 4 - Subsequent literature by Bergson, Little, Kaldor and others on the function of social welfare; a) How Pareto’s optimum (second criterion) is realised in practice; b) “Constitutional” approach as a first limit to “deviations” from the optimum public choice policy; c) Other limits to “deviations”: towards the minimal State. 5.- Relationship between Pareto’s second criterion and Samuelson’s theorem. For the revision of the current definition of public good as “identity”. 6.- About “functional finance”. Pre-Keynesian view and productivism of public financial activity. 7.- About the weighting of “value judgments” in scientific analysis. Application to contributive capacity: the tax on exchanges. 8.- About the effects of taxes and public expenditure in a collectivistic system. 9.- More specific subjects: a) Amortisation of public debt; b) Double taxation of savings; c) Tributary burden in international comparisons.*

1. Foreword. The man and the Master.

Ernesto d'Albergo** was a great man in how he presented himself, for the nobility of his feelings, the breadth and depth of his scientific knowledge, for his expansive culture. He was probably the

* Nino Luciani, Full Professor of Science of Finance at the University of Bologna, pupil of d'Albergo.

E-mail: nino.luciani@alice.it. For scientific contact, please see: <http://amsacta.unibo.it/3417/>

** **Biographical note by Nella, his daughter.** *He was born in 1902 at Noto (Syracuse) to a noble Sicilian family. He was very close to his father, Nobleman Salvatore d'Albergo della Cimarra, illustrious lawyer, and to his mother, Nella Scirpa d'Agata. He died in Rome in 1974. He rests in Noto (Syracuse), in the family grave.*

He studied at Bocconi University, where he graduated in 1924. After a probation period in the administrative offices of the Banca Nazionale di Credito, his aptitudes were rewarded with the promotion to manager of the Central Administration Studies Office of the same bank. Later, when he moved to a university career, he was Economic Consultant to the Credito Italiano Central Office. In 1930 he obtained the university teaching licence and was Adjunct Professor in his discipline, for the part relating to local finance, at the Sacro Cuore University and Milan's State University. He was Full Professor in the Science of Finance at Ferrara, Siena, Trieste, Venice (Cà Foscari) and Bologna.

In Bologna (1941–1955), he was Dean of the Economy and Commerce Faculty from 1947 to 1952. In that period, as the old university site had been destroyed during the war, he was instrumental in the realisation of the new site according to modern architectural and urbanistic concepts, although still respecting the traditional Bolognese architecture.

In 1956 he obtained the Science of Finance Chair at the Faculty of Political Sciences at La Sapienza University in Rome, where he achieved the satisfaction of separating Science of Finance from Financial Law. He taught in Rome until he was granted leave of absence.

From 1945 until his passing, he directed Rivista Bancaria [Banking Review], Minerva Bancaria. He was president of the National Association of Italian Tax Experts from 1952 until his death. In the fifties he was President of the Real Estate Confederation for nearly a decade. After the war he was elected a Municipal Councillor in Milan. In 1963 he received recognition for services to his country in the field of Public Finance from the President of the Republic, G. Saragat, following the recommendation of the Finance Minister, R. Tremelloni, and he was awarded a gold medal.

greatest scientific exponent of the science of finance in Italy in the last century. His “Public finance economy”, as proposed in the English version, needs to be considered as a reflective scientific review of the best Italian and international works produced in this field up to 1974.

For an initial introduction to his work I refer you to the presentation by G. Gola (one of his pupils, before my time) and D. da Empoli (see: <http://amsacta.cib.unibo.it/2571/>, which is the Italian edition of this text, now published also in English by the University of Bologna). Another authoritative source are “*Scritti Scelti*” [Selected Writings] ***.

E. d’Albergo is not very well known in the international scene, and he is also little known to the last generation of academics in the science of finance in Italy.

The reason for this, perhaps, is that he was disadvantaged by the Italian language, less used than English, as he used to say, or perhaps by his proud Sicilian character. The international supremacy of the English language is gradually eroding local traditions, perhaps because the young do not appreciate that respect for one’s own roots is “always” worthwhile. I believe that an element of dignity should encourage everyone (not only Italians) to use two languages (the national one and English), according to the Greek customs.

It remains a fact that Ernesto d’Albergo had experienced some controversy, including with the Nobel Prize winner James Buchanan, with regard to the “voluntaristic or compulsive nature of taxation”. I will, however, return to this point later. I believe that the two respective approaches to collective decisions (d’Albergo’s one, of coercive nature; Buchanan’s one, of contractualistic nature) could be harmonised, by considering d’Albergo’s approach as a highly theoretical “first approximation”, while considering Buchanan’s one as a second and further approximation to the real event.

The same had happened with R. A. Mundell (also a Nobel Prize winner), who had investigated in an interesting study the possibility of using the fiscal lever (fiscal balance) only for market equilibrium, within a country, and the monetary lever (management of interest rate) only for managing the balance of international payments.

In an introductory note to my essay in 1974 (it would be his last written work), he wrote that “the praise” of the Nobel judges for a short article by Mundell was excessive and not relevant.¹ However, also on that occasion, the dominance of the English language had given a voice to Mundell but not to d’Albergo.

He won the Cremisini Prize and in 1972 the Lincei National Academi awarded him the Saverio Nitti Foundation Prize for developing the study and teaching of financial disciplines over 40 years of activity, with particular regard to their public aspects.

Ernesto d’Albergo remained always very fond of Sicily, even though he did not often travel back to his land. He was dedicated to his family and his family roots, and had intended to write the history of his lineage, which had shined in literature and law. An ancestor of note was the Marquis Corradino d’Albergo, patriot and poet who organised literary cultural gatherings in Palermo in the early 19th century together with his wife Sofia, of Saxon origin. The same Corradino d’Albergo established himself in Florence in 1852, where he was President of the Pontaniana Academy. After his death, he was buried in the Florence Charterhouse.

Ernesto d’Albergo deeply loved Tuscany, which he chose as his work and holiday abode. He built a small holiday villa in the countryside on the hills between Lucca and Pisa, where he loved spending many days each year.

*** Selected by G. Gola, G. La Volpe, N. Luciani, V. Russo, G. Trupiano, and published by the Institute of Economic, Financial and Statistical Studies (now the Department of Theory and Quantitative Methods for Political Choices) of the Faculty of Political Sciences of La Sapienza University in Rome, 1980.

G. Gola (Full Professor of Science of Finance, University of Bologna), V. Russo (Full Professor of Science of Finance, University of Roma “La Sapienza”), G. Trupiano (Full Professor of Science of Finance, University of Roma TRE), were Pupils of E.d’Albergo

¹ R.A. Mundell, “The appropriate use of monetary and fiscal policy for internal and external stability”, 1962, translated into Italian in Various Authors (edited by A. Pedone), *La politica fiscale [Fiscal policy]*, Il Mulino, Bologna, 1971.

2. Separation of science of finance from financial law. Relationship between science of finance and political economy. With regard to the scientific work of Ernesto d'Albergo, I will start by remembering a question of methodology that he put forward as a precondition to the scientific and teaching community: the *separation of the science of finance from financial law*. This was in contrast to the old masters, such as B. Griziotti.

This separation first came about in Italian universities in 1963, when he obtained, from Zoli's government, with a parliamentary law, the compulsory introduction of science of finance in the second year of the degree course of political sciences, following on from political economy.

D'Albergo celebrated the event in the same year in *Rivista Bancaria* [Banking Review], with the article "Per il progresso degli studi finanziari" [For the progress of financial studies], in which he differentiated the methodological requirements of the "specialisation in knowledge", specific to personal investigation in a single discipline, from the requirements of the synthesis of knowledge, specific to the global view of the various disciplines.

It was a direction (first indicated by A. De Viti De Marco) which has become prevalent, even more so in the rest of the world, where the Science of finance is known as "economic theory of public finance" or "public economy". I fully agree with this.

Relationship between science of finance and political economy. In the definition of the relationship between political economy and the science of finance, d'Albergo draws from Pareto, even though the latter had verbally denied the scientific character of the science of finance in his time. More precisely, in his "Mathematical economy" of 1909, Pareto states that, once the conditions of general economic equilibrium have been considered, the constraints of this same equilibrium need to be considered, and this would fall in the domain of *applied economy*. Among the list of these constraints, d'Albergo found taxes, public debt and public expenditure, which are the subjects of the science of finance today.

3. The governing class as "single subject" in public choices. This is the Master's most important scientific contribution. I believe that it would be useful to sum it up in the following points:

- a) differentiation between Pareto's first and second criteria;
- b) Pareto's second criterion;
- c) relationship between Pareto's second criterion (hereafter defined as "second Paretian criterion") and the "second theorem of welfare economy";
- d) how the second Paretian criterion is realised in practice;
- e) its relationship with Samuelson's theorem;
- f) relationship between political micro-economy and science of finance.

a) Differentiation between the first and the second Paretian criteria. The greater part of Ernesto d'Albergo's scientific work addresses the problem of the identification of the "decision-maker" and of the economic uniformities of public choices. G. Gola was of the same view. I refer to his numerous studies on the subject in the footnote².

² I will recall: "Intorno al concetto di costo dell'attività finanziaria" [Regarding the concept of the cost of financial activity], 1932; the 1944 edition of his course "Scienza del finanze ad uso degli studenti" [Science of finance for students]; the 1952 edition of his *Economia della Finanza pubblica* [Public finance economy], with the 1971 "Aggiornamenti" [Updates]; eight essays on "Finanza pubblica e benessere in unico modello" [Public finance and welfare in a single model], published in *Il giornale degli economisti* [Economist journal] in 1963–64, 1968, and again in 1971; "Premesse scientifiche generali e teoria dell'illusione finanziaria" [Scientific premises and the theory of financial illusion], 1959.

These essays address the topic, central to the science of finance, of the identification of the decision-maker in public finance choices, as political economy had identified individuals as the subjects in the issue of personal choices.

D'Albergo identified the “governing class” as the single subject of public choices, helped by the scientific approach of V. Pareto and M. Pantaleoni. In his view, these were choices that the governing class makes for the community or, even better, the governing class (as economic subject) makes economic choices on behalf of the community, as interpreter of the needs of the same community.

In agreement with these authors, Ernesto d'Albergo also believed that the governing class does not make choices to serve its own interests, and this explains his position with respect to J. Buchanan and, earlier, with C. Cosciani, as these two authors believed that members of the governing class also have their own function of “individual” utility³.

Other authors objected that the needs of a “community”, as a sentient subject, do not exist and that therefore also the needs of a community must be considered as the needs of individuals. And therefore, as individual needs cannot be compared (no bridge), the scientific foundation, in the economic field, of public choices made by this so-called governing class fails. Einaudi, according to whom the “stethoscope” for the measurement of individual moods does not exist, had also taken part in this debate.

However, according to Ernesto d'Albergo, the sociologist Pareto offered the opening to understanding reality, and therefore the means to overcome these limitations.

As it is known, Pareto (after publishing his *Trattato di sociologia [Sociology treatise]* and *Sistemi socialisti [Socialist systems]*) summed up in 1913 his approach to collective hedonistic maximums respectively **for** and **of** the community to economists in the *Economist journal*.

D'Albergo defined the “**first criterion**” as the “maximum **for** the community” (what economists refer to as the “*Paretian optimum*”) and the “**second criterion**” as the maximum **of** the community” (for public choices).

According to Pareto, to obtain the maximum utility **for** the community, the necessary condition is equalisation of marginal rates of substitution between various consumption goods for all individuals, by means of exchange. According to Pareto, furthermore, this condition is realised in practice, in the perfect competition market, and this represents the so-called **first theorem of welfare economy**.

The explanation of the theorem (which can be grasped but which is really nebulous in his “*Manuale di economia politica*” [*Manual of political economy*], even though we make reference to it for its demonstration) consists in the observation that, in the perfect competitive market, all consumers adapt to market prices to optimise their own personal situation, comparing the rate of marginal substitution of goods to the reverse of the ratio of the respective prices; and that for each of the goods in question the price is the same for all consumers.

This optimum (as I have said before, commonly referred to as “Paretian optimum”) leads all consumers to improve their own welfare, and certainly not to worsen it, with respect to the initial situation (the white area of Graph 1 contain possible consensual solutions). This is a political economy approach, and it presumes a voluntary choice, also for the obvious reason that no one would agree to accept to a reorganisation of assets that made their position worse than before.

Several choices would be possible (some more favourable to a subject involved in exchanges than another) along the contract curve (even though within certain limits) in the exchange relationship, and the traditional theory tells us that the final chosen combination depends on the **contractual strength** of the subjects involved.

³ On this aspect, I did a study with the book: Luciani N. (2005), *Economia delle scelte pubbliche di beni e servizi*, Franco Angeli, Milano 1992 [*Economy of public goods and services*], <http://amsacta.unibo.it/3417/>.

The yellow area (of Graph 1), however, is the field of coercive choices, as it contains the tangency points where only the position of one of the two worsens while that of the other improves, compared to their respective initial position (that is to say: in the yellow area above the white area, the position of B worsens from the initial position, while in the yellow area below the white area, the position of A worsens with respect to the initial position). Therefore obtaining the consent of both is not likely.



Grafico 1

At this point a problem arises: given that both subjects had identified their Pareto optimality (in political economy), if the voluntary choice of the two subjects were to be forcibly modified further inside white area (in the field of voluntary choices), or outside it of Graph 1 (yellow area, namely in the field of coercive choices), would it be possible to overall improve the welfare of the two consumers (that is, as if they were a single subject)?

This approach is at a great level of abstraction: there is no distinction between private goods and public goods (ie without distinction according to the so-called principle of exclusion or to the divisibility, between the users), but between “private decision-makers” and “public decision-makers”, for the use of goods and services in general.

The solution to this problem comes from the *second criterion*.

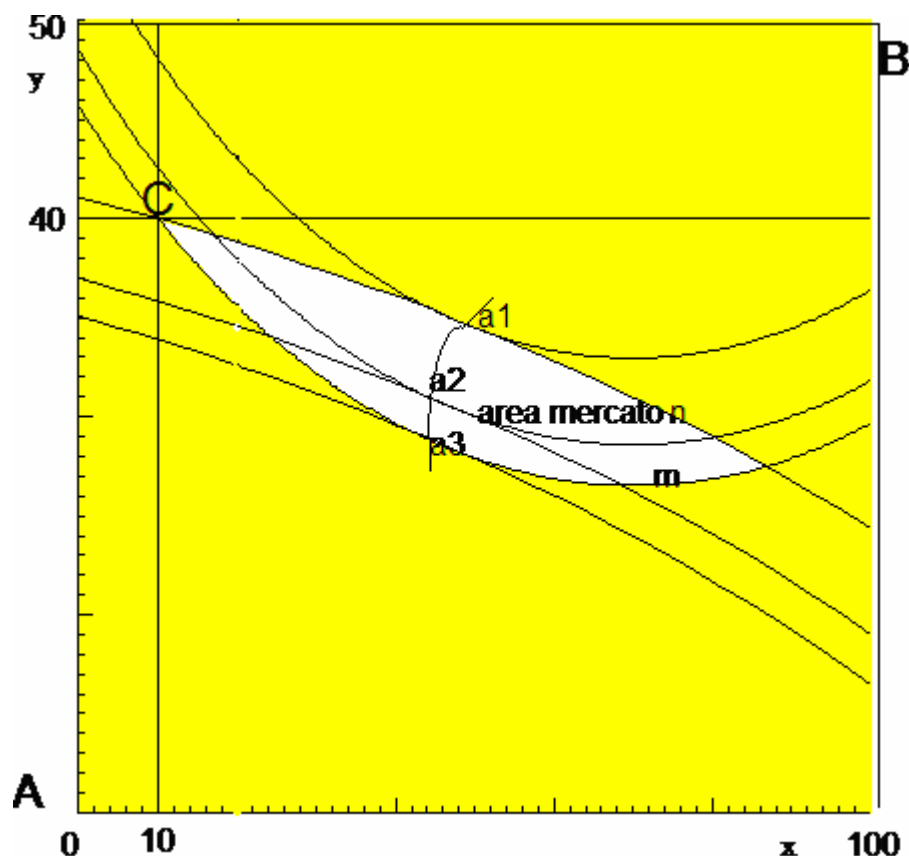
b) Pareto's second criterion; Pareto asked the question: is it possible to conceive a further improvement to the welfare of the community, with respect to the maximum “for” the community? Pareto defined this further improvement as the maximum *of the* community, and d'Albergo renamed it “Pareto's second criterion”.

To achieve this passage it was necessary to join all the individual utility functions, overcoming the old “no bridge” issue.

According to Pareto, in the same way as it is possible to admit that each individual's evaluations relate to himself, so it is possible to admit that he has views relating to other individuals. If this is so, a function of collective utility can also be admitted as the sum of individual functions of utility, according to the judgment of individuals or of each individual representative of the various social classes.

The expression "according to the judgment" indicates the implemented homogenisation of individual evaluations through coefficients of homogenisation of the presumed evaluations of others in relation to oneself, carried out by the individual⁴.

The same can be done, Pareto continued, with a second individual, or a second social class and so on, to finally reach a series comprising as many functions of collective utilities as there are individuals or social classes at the start.

Once this has been done, and taking one of these functions as the baseline, it is also possible to admit the possibility that the governing class will reshape it, correcting in turn the coefficients used in the initial function.

Finally, when we reach such a function of collective utility, as a sum of functions of individual utilities homogenised according to the judgment of the governing class, that becomes the public utility function, taken as the basis for public choices. This is Pareto's conclusion, as interpreted by Ernesto d'Albergo.

I must add that the fruitfulness of the Paretian model was at the time shared by several others of the Italian science of finance academics. I am referring to B. Griziotti, G. Borgatta, M. Fasiani and, later to G. Sensini, G. Gola and G. Parravicini⁵, defending the originality and pioneering priority of this model.

Once the construction of a public utility function has been scientifically legitimised, we could then continue with the search for its optimum conditions. Therefore, presuming the problem of comparability of the income utility of various individuals (or social classes) that make up the community to have been resolved; and having adopted a utility function of the set of incomes of the same individuals; and having hypothesized that the decreasing trend of the function of marginal utility

⁴ I want to make an example to clarify what it means to use "the coefficients of homogeneity of the utility functions of two individuals". Suppose that two individuals (B and C) have (each) an income of \$100.

A third individual (A) believes that:

- a) according to individual B, the marginal utility of his income (\$100) is 20 (quantity);
- b) according to individual C, the marginal utility of his income (\$100) is 30 (quantity).

The common opinion is that the two assessments are not directly comparable (because individuals have different sensitivities).

The problem of comparison could be solved by assuming that the individual (A) transforms the two evaluations into other, comparable ones. For example, he could consider that the marginal utility of B's income is 10; and the marginal utility of C's income is 30. This means that A has multiplied the marginal utility of 20 by a coefficient $M_1 = 0.5$, and that he also multiplied the marginal utility 30 by a coefficient $M_2 = 1$.

⁵ See: Griziotti, B. (1943), "Fatti e teorie delle finanze in Vilfredo Pareto" [Facts and theories in Vilfredo Pareto's finance], in *Rivista di diritto finanziario e scienza delle finanze [Journal of financial law and the science of finance]*, 1943, I; Borgatta, G. (1923), "Vilfredo Pareto", in *La riforma sociale [Social reform]*, Sept–Oct; Borgatta, G. (1948), "Vilfredo Pareto", in *Rivista Bancaria [Banking Review]*, *Minerva Bancaria*, 471; Fasiani, M. (1941), *Principi di scienza delle finanze [Principles of the science of finance]*, Vol. I, Chapter II, Giappichelli, Turin, 1949; Fasiani, M. (1949), "Contributi di Pareto alla scienza delle finanze" [Pareto's contributions to the science of finance], in *Giornale degli economisti [Economist journal]*, March–April, 129–73; Sensini, G. (1948), *Corrispondenza di Vilfredo Pareto [Vilfredo Pareto's correspondence]*, Cedam, Padua; Sensini, G. (1960) "Fondamenti razionali comuni della economia finanziaria" [Rational common foundations of financial economy], in *Giornale degli economisti [Economist journal]*, May–June. Reprinted in *Scritti di finanza pubblica [Public finance essays]*, p. 71, CLUEB, Bologna 1991; Parravicini, G. (1967), "Sulla teoria delle scelte finanziarie" [About the theory of financial choices], in *Giornale degli economisti e Annali di economia [Economist journal and economy annals]*, July–August.

of income of the same individuals is known, Pareto proves that the conditions of maximum utility of the community can be found by redistributing the resources among the various individuals (or social classes) so as to nullify the sum of the variations of the function of collective utility, that is to say:

$$0 = M_1 \delta\varphi_1 + M_2 \delta\varphi_2 + M_3 \delta\varphi_3 + \dots \quad [1]$$

where: $M_i = \alpha_i \beta_i$, for $i = 1, 2, \dots, n$, are the mentioned weighting coefficients (for the purpose of homogenisation, see note 4) of the functions of income utility of the individuals included in the various social classes $1, 2, 3, \dots, n$ ⁶.

The utilitarian negative and positive variations transposed by d'Albergo in the science of finance are, respectively, the result of the changes of the distribution of individual resources through **taxation** and **public expenditure**, and which therefore are proven to be the instrument for the redistribution of income among social classes. This condition allowed Pareto to identify the utility maximum **of the** community, which we have already renamed the "second Paretian criterion", of a relatively higher level than that of the maximum referred to by the first principle.

This judgment of the governing class, however, even if hypothetically admissible: was it something that had a correspondence in theoretical and historical truth?

E. d'Albergo stated:

1) Public financial choices happen and they are a necessity. At least in many cases, not taking public decisions would cause serious damage to all individuals;

2) There is empirical evidence that individuals react in the same way to many stimuli; therefore there is a *common feeling basis* that encompasses the governing class as well as every individual;

3) Amilcare Puviani, who many will recall, had founded his theory of financial illusions precisely on the fact that individuals have very similar reactions depending on the various types of taxes, and in various circumstances. Without this prerequisite, no uniformity could be identified in the context of financial illusions. E. d'Albergo later retraced the elements of this common feeling basis even in the Gospels, where it is said that a widow who gives two small coins to the temple's coffers gives more than the rich Pharisee with his talents. Finally, Duesenberry will confirm much later, as the result of his empirical investigations in American society, that individuals adopt the behaviour of the social class into which they gradually move, as their income grows.

I go back to optimal condition (equation [1]), above, that is to say: make the sum of the weighted marginal utility of income of social classes (after deduction of taxes and addition of public expenditure), equal to zero (see equation [1], above). This is a general expression applicable to the many social classes, of which the community is composed.

The optimal condition may also be expressed in a simplified manner by means of Edgeworth' box, which facilitates the understanding of the passage from the first to the second criterion.

For the purpose of this illustration, we assume that the community is made up of only two people, with two types of goods in specific amounts and with specific utility functions.

Let's then assume that there is a third party (let's say an omniscient government) that employs certain weighting coefficients (M in equation [1]). For simplicity of exposition, let's hypothesise them to be equal to unity (i.e., $M_i = 1$).

Let's go back to graph 1, modified as in Figure 2 .

Let's suppose that the two individuals, given the initial resources (at point C) and given an exchange rate between the two types of goods (X and Y), have agreed to move to point a1, where A's

⁶ The coefficients α are hypothetically used by a given individual or social class for themselves and for other individuals or social classes, and coefficients β are hypothetically the coefficients used by the governing class to correct coefficients, in its own way.

position improves, compared to the initial position, and where B's position does not improve but it does not get worse.

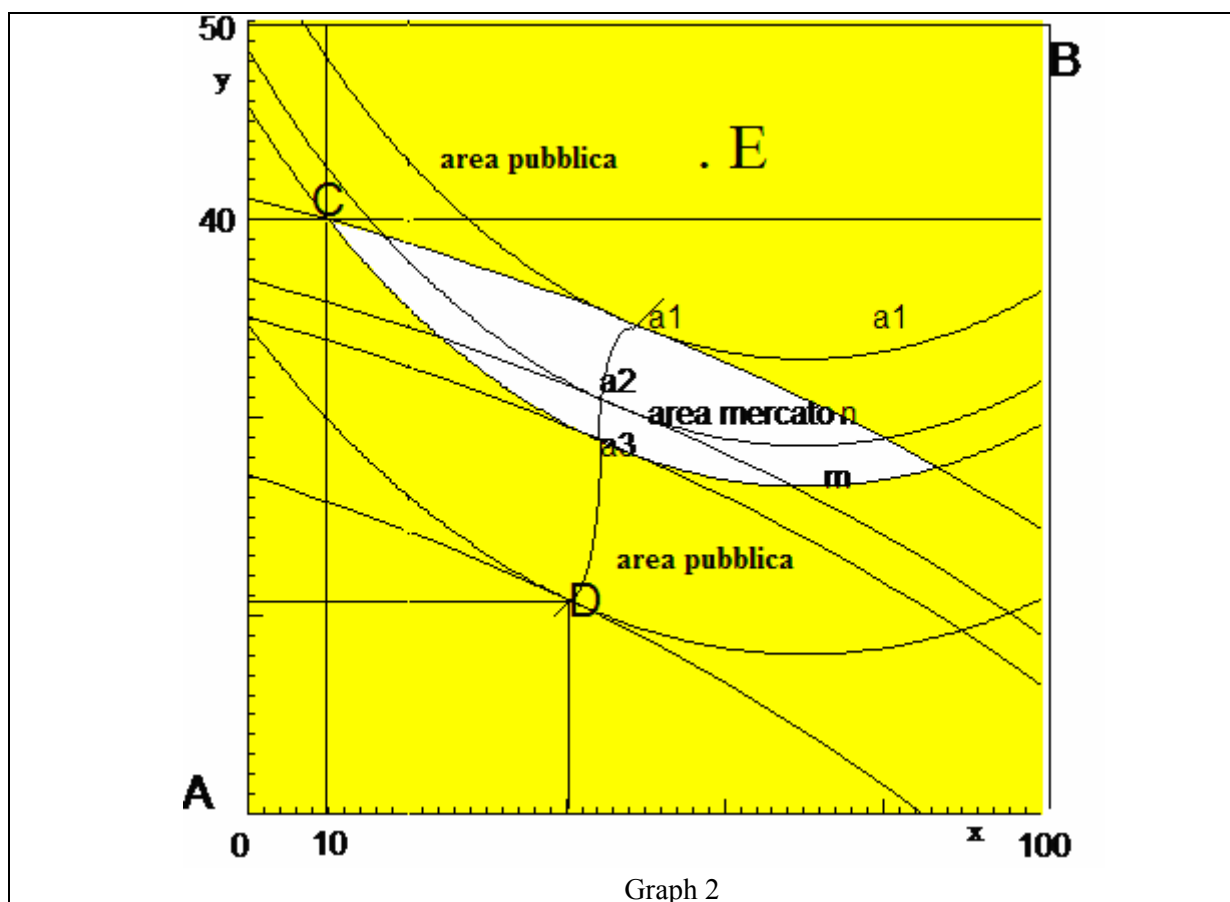

Let's now assume that the government (given the hypotheses made above) decides to maximize the welfare of the two individuals, considered as a whole (that is the sum of utilities of income of the two individuals). According to calculations made by me, (for example, using the functions described in the note⁷), the maximum for the two individuals (considered as a whole) is in D (i.e., inside the yellow area below the white area). This means that the government takes goods away from individual A, to give to individual B. This position improves the wellbeing of the community as a whole, but only further improves the position of B; on the other hand, the position of A worsens even when compared to the initial position.

c) Relationship between Pareto's second criterion and the "second theorem of welfare economy".

For clarity, I will recall here the content of the "second theorem of welfare economy". This theorem states that, as in the competitive market, a Paretian maximum will occur (starting from a given initial distribution of wealth among individuals), as it will also do (always in the competitive market) when starting from a distribution different from the initial one.

At this point, as there are some distributions that are better and some that are worse among all the possible options available, we conclude that the Paretian optimum is compatible with the realisation of a new "best" distribution.

However, none of the academics appear to know what the best distribution is. For example, the collective conscience appears to consider that a distribution characterised by people in great poverty

and others in extreme wealth is worse than another in which some of these polar positions are in part attenuated. However, this is also a generic argument and a statistical fact, while it would be more rigorous to set the problem against a long time span, in which it could be possible to justify the temporary poverty of some, as long as the wealth of others is used for the development of the GDP of an entire country, and therefore (at a later stage) with beneficial repercussions for poor people.

These solutions, however, precisely because they involve a long-lasting public commitment in terms of redistribution, are rarely compatible with the market. As is also known, some experts have tried to break the open-endedness of the concept of “optimal distribution” without compromising the market. The well-known compensation principle, call the Kaldor principle, comes into play here.

On the other hand, others have tried to overcome this open-endedness with some indication of more general value than that of the famous compensation principle. For example, the possibility of modifying the distribution with public expenditure (in favour of some citizens) and fixed-amount taxes charged to some other citizens has been examined. The combined use of these two instruments is suggested following the deliberate choice of not modifying the relative prices of goods.

However, right after doing this, it has been observed that it is impossible to demonstrate that the new distribution of wealth is better or worse than the original one, even when using instruments that are neutral to prices⁷.

If, after having recalled these arguments, which are quite widespread, and after regarding the “second theorem of welfare economy”, we consider the “second Paretian criterion”, we realise immediately that the latter offers an investigative means that is very relevant for significant steps to delimit, in pure theory, the concept of “optimal distribution”.

Let's reconsider Edgeworth's box, given an initial distribution indicated by the point *C*, in which the area of the possible trades between the two subjects involved in the exchange (to improve their own welfare) is delimited by the field inside the two curves *n* and *m*.

Let's now presume we move on to a casual redistribution that finds the two individuals at point *D*. The graphic, here below, shows that the new area of the possible trades becomes that delimited by the curves *n* and *q*.

After this simple observation, it is easy to demonstrate that, among all the distributions possible, there are some that are compatible with the market (even when modifying the relative prices).

Assuming that the initial optimum trade is *P3*, it can be seen that if the public hand were to impose a new distribution with taxes and public expenditure (which does not necessarily involve fixed taxes), used so as to remain along the trade curve (for example passing from *P3* to *P2*), there would immediately be another Paretian optimum (first criterion), without the need for new adjustments between the subjects involved in the exchange. And if this modification managed to also realise the second criterion (that is, that what has been taken away from *B* is of lesser utility than the benefit to *A*); and precisely that if the sum of the damage and of the benefit is marginally zero, this would be the best redistribution among the available ones. All this, of course, applies in pure theory, on the basis of the value judgment of the governing class.

I conclude that Pareto's second criterion offers a very relevant insight into the second theorem of welfare economy.

⁷ See the excursus (reflecting this rather incompetent mode of examining this issue) by P. Bosi, *Scienza delle Finanze [Science of finance]*, Il Mulino Publisher, 1996, p. 49 and following.

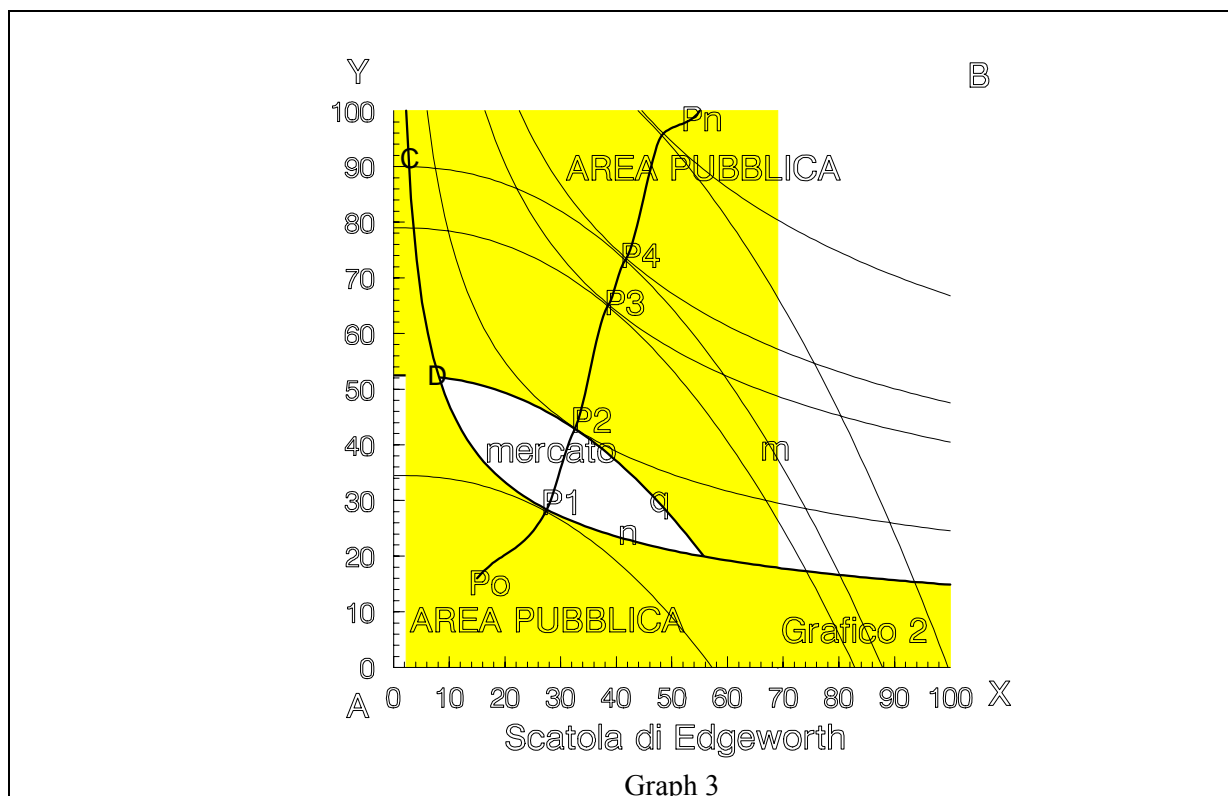

4. Subsequent literature by Bergson, Little, Kaldor and others on the function of social welfare.

Pareto's social model appeared in 1913, in the most prestigious economic journal for economists (*Giornale degli Economisti* [*Economist journal*]). Even though the origins of the function of social welfare are normally attributed to Bergson in 1938, there is no doubt that Pareto's model has had a direct influence much earlier on Italian financial scientists, creating the prerequisites for a first important tradition.

M. Pantaleoni (a near contemporary of his) was certainly in agreement with him with regard to "maximum hedonistic systems" and the "criteria of distribution of public expenditure". Furthermore, Pareto's seed seems to have found fertile soil in Griziotti⁸ Borgatta⁹, in Fasiani¹⁰.

We find the next link, more authoritative but unfortunately with very few other Italian experts ready to follow Pareto's teachings, in Ernesto d'Albergo: among the few we find G. Sensini¹¹, G. La Volpe¹² and G. Gola¹³, one of Ernesto d'Albergo's pupils, G. Parravicini¹⁴.

⁸ Griziotti, B. (1943), "Fatti e teorie delle finanze in Vilfredo Pareto" [*Facts and theories in Vilfredo Pareto's finance*], in *Rivista di diritto finanziario e scienza delle finanze* [*Journal of financial law and of the science of finance*], I.

⁹ Borgatta, G. (1923), "Vilfredo Pareto", in *La riforma sociale* [*Social reform*], Sept–Oct; Borgatta, G. (1948), "Vilfredo Pareto", in *Rivista Bancaria* [*Banking Review*], Minerva Bancaria, 471.

¹⁰ Fasiani, M. (1941), *Principi di scienza delle finanze* [*Principles of the science of finance*], Vol. I, Chapter II, Giappichelli, Turin; Fasiani, M. (1949), "Contributi di Pareto alla scienza delle finanze" [*Pareto's contributions to the science of finance*], in *Giornale degli economisti* [*Economist journal*], March–April, 129-73.

¹¹ Sensini, G. (1948), *Corrispondenza di Vilfredo Pareto* [*Vilfredo Pareto's correspondence*], Cedam, Padua.

¹² La Volpe, G. (1987), *Convenienza Economica Collettiva e Attività Pubblica nell'Economia* (Raccolta di scritti) [*Collective economic convenience and public activity in economy* (Collection of essays)], CEDAM, Padua, 1987.

¹³ Gola, G. (1960), *Fondamenti razionali comuni della economia finanziaria e dell'economia del benessere*, *Scritti*

Finally, we recall M. Florio's recent excursus¹⁵ on Pareto and E. Giardina¹⁶.

Generally speaking, however, this literature has remained in the shade, definitely because of linguistic difficulties.

This subject has been extensively discussed in the literature after Pareto: for example, if the function of social welfare can be configured as the sum of functions of individual utilities (Bergson); if the same functions are homogeneous or if it is necessary, on the other hand, to proceed to their homogenisation according to the judgment of a *third* person, before adding them up (Little); if it is possible and if it makes sense to construct a coherent order of preferences, applicable to all, through the aggregation of individuals' orders of preference (Arrow); if the application of a compensation principle, in objective terms, through which all can improve and none can make their situation worse, thanks to the compensation, is possible and generally applicable (Kaldor, with Scitowskj's observations), etc. .

a) How Pareto's optimum is realised in practice (second criterion).

A second vein of d'Albergo's thought relates to the circumstances in which the "second Paretian principle" is realised for public choices¹⁷ and aspects linked to it.

According to d'Albergo, the "Paretian optimum" (second criterion) is realised through coercion in the State organisation. In an analogous manner, Pareto had stated that the Paretian optimum (first criterion) is realised in the perfect competitive market.

This position by d'Albergo is the opposite of other literature, according to which the government is not omniscient, and also adds that the idea of "good government" is science fiction, and in particular negates that the government is motivated exclusively by the search for the common good.

The demonstrability that, in pure theory, a public decision can improve the welfare of society overall (with respect to that realised by the market for citizens overall) needs to be separated, I think, from the possibility that that decision is implemented.

There is no doubt, I believe, on the first point. In pure theory it is possible that, by moving (through public intervention) the two subjects involved in the exchange from point *P3* to point *P2* (see Figure 2), A gains more than B loses (or vice versa) and in this case the welfare of the two increases (or decreases) overall. Therefore, public intervention is potentially capable of increasing (or decreasing) the collective welfare, with regard to what is possible with the market.

With regard to the second point, an array of disturbing possibilities presents itself to us. In fact, historically there are many cases, very normal ones, of the limitations of many freedoms by public intervention, but also cases of much pain and blood spilling caused to populations by public powers (in the name of Reason of State).

It is known that, with regard to the interpretation of facts, there is a wide body of literature and that this is concerned with the delimitation of the possible extension in the public field, to which the possibilities of deviations, or the absence thereof, of the State from the common good.

di finanza pubblica [Common rational bases of financial economy and welfare economy (Public finance essays)], p. 71 and following, CLUEB, Bologna 1991.

¹⁴ Parravicini, G. (1967), "Sulla teoria delle scelte finanziarie" [About the theory of financial choices], in *Giornale degli economisti [Economist journal]*, July–August.

¹⁵ Florio, M. (1988), *Vilfredo Pareto fra Scienza delle finanze e Welfare Economics: alle origini del dibattito sui criteri di benessere sociale [Vilfredo Pareto, between the science of finance and welfare economy: at the origins of the debate on criteria of social welfare]*, in "Rivista di diritto finanziario e scienza delle finanze" [Journal of financial law and the science of finance], 489.

¹⁶ Giardina, E. (1969), "Le scelte finanziarie ed il massimo paretiano di utilità collettiva" [Financial choices and Pareto's utility maximum, *Scritti scelti (1960–2007) [Selected essays (1960–2007)]*, Franco Angeli, Milan 2008.

¹⁷ I recall: "Teoria dello 'scambio volontario' e dell'utilità collettiva" [Theory of the 'voluntary exchange' and of collective utility], 1958; *Elementi volontaristici e coattivi nei rapporti finanziari con gli Enti pubblici [Voluntary and compulsive elements in financial relations with public bodies]*, 1962.

How relevant the policymakers' errors are can be seen in part in the failure of the economic systems of the former real socialist countries, that is to say, those countries where, after adopting distributive equality as one of their political priority objectives, over the course of time the country has achieved a gradually diminishing GDP; and we can see it in the extensive unemployment of Western countries, in given phases of the economic cycle, where the effort towards redistribution has undoubtedly been very significant, as proven by the ratio between public expenditure and GDP, which in Italy went from 33% in 1960 to 55% in 2008.

The *second* weak aspect of these models of redistribution of the welfare economy is that they are static, in other words they evaluate the situation when things settle down.

The relative limit to the staticity of the model can, however, be "re-dimensioned" assuming by definition that these entities are redefined as the "actual value" of current economic events, as time progresses¹⁸. However, in practice these errors are inevitable, even with theoretical support for this limit (because static). Therefore, research must be extended so as to avoid errors, identifying first approximation rules.

The identification of *constitutional rules* to guarantee the safety of the community from deviations, such as the introduction of limits of renewability of electoral mandates of the governing class, is a first relevant method.

Other methods have been the introduction of some constraints, such as the balancing of budgets, or more stringent rules (minimal or ultra-minimal State). I will recall Rawls' ideas¹⁹ and of Nozick²⁰ in favour of the "minimal" and "ultra-minimal" "welfare state". I will return to this in the following paragraph.

b) "Constitutional" approach as the first limit of the "deviations" of the policy from the optimum public choice.

Constitutional choices have as their object the principal foundations of civil coexistence and of the organization of the State and local governments. For this reason they are binding, that is something that comes about as an expression of a people's general feelings and rules for coexistence, therefore

¹⁸ Precisely, in dynamic terms, the previously mentioned condition of Paretian optimum in public finance (second criterion), in other words

$$0 = M_1 \delta\varphi_1 + M_2 \delta\varphi_2 + M_3 \delta\varphi_3 + \dots,$$

becomes:

$$M_1 \frac{\partial\varphi_1}{\partial C_{1_0}} = M_2 \frac{\partial\varphi_2}{\partial C_{2_0}} = \dots = M_N \frac{\partial\varphi_N}{\partial C_{N_0}}$$

$$C_0 = C_{1_0} + C_{2_0} + \dots + C_{N_0}$$

where $I, 2, \dots, N$ are the various individuals (or social groups) that make up the community, and $C_{1_0}, C_{2_0}, C_{N_0}$ are respectively the actual values, at a given interest rate, of the future incomes of the same, according to the prediction of the governing class. In this sense the modification of the distribution (with respect to that to be implemented on the basis of the optimum, in statistical terms) depends not only on the income that the governing class expects individuals, or social groups, to achieve but also on the interest rate, chosen by the governing class, to achieve these expectations. For more details, see: Luciani, N. (1997), "Finanza pubblica e welfare state nel modello Pareto-d'Albergo" [Public finance and welfare state in the Pareto-d'Albergo model], in Various authors (1997), edited by D. da Empoli and G. Muraro, *Verso un nuovo stato sociale [Towards a new social state]*, Franco Angeli, Milan.

The consequences of this approach can be very disappointing for those who would hurriedly expect to be able to increase collective welfare only through egalitarian policies.

¹⁹ Rawls, J. (1977), *Giustizia distributiva [Distributive justice]*, in "Le ragioni della giustizia" [The reasons for justice], Biblioteca della libertà, XIV, April–September, 65/66, 45-75.

²⁰ R. Nozick, R. (1980), *Anarchy, State and Utopia*, in "Basic Books", New York, pp. 3, 6-7, 10-17, 22-25, 113-5, 118-119, 297, 333-334.

they are long-lasting because they are unanimously approved rules. The rule on electoral quorum for the validity of current decisions could fall within the definition of preventive “constitutional” decisions. Constitutional rules are not generally necessarily written (see the UK).

Post-constitutional choices, on the other hand, have a contractual nature as they arise from plea agreements among social groups. They are the result of a damage limitation compromise for the solution of current problems. They ultimately take the form of approval by parliament, in compliance with majority and minority rules.

d’Albergo was totally opposed to public choice school of thought. In his opinion, public decisions are made by the ruling class, they are not voluntary agreements.

We might believe that this approach is a correct first approximation, and that the public choice school of thought opens the way to explanations of second and further approximation.

It is not possible, I believe, to deny that in the context of public choice it is possible to rank degrees of “coercivity” and that, among these, constitutional choices are on top in terms of maximum coercion, that is to say they are totally protected by common conscience so as not to allow dissent. All other forms of choice follow (that is, they are the object of frequent trade-offs and renegotiations).

I would define constitutional choices as “collective choices”, to maintain an adjective which is truly of the Italian school, and I would define “public choices” post-constitutional ones, those belonging to the public choice school of thought, which are only partially voluntary (with certain exceptions).

The relationship between the two has analogies with those of general equilibrium and of partial equilibrium, in the sense that the “laws” of general economic equilibrium are also deterministic (in other words mechanically imposed) on individuals, even though they are the result of individual contributions, and are therefore originally voluntaristic.

On the other hand, those trends have a quasi-contractual or “neo-contractual” nature because they fall within the context of political micro-decisions. The combination of these two views allows, I believe, a relatively more realistic approach in public choices, than the placing of them against each other.

I would then also like to observe that, technically, decisions are of “dictatorial” type also in democracy, albeit in a “given way”, in spite of the democracy definition. In fact, direct democracy is not possible and therefore the community decides “through representation”, after having made some general choices. For example, in the Italian parliament the Senate is made up of 315 members who are then subdivided into committees of 15 members, who ultimately decide by majority, when we had started with an electorate of 40 million voters. In the end the decision is made by eight people, in the best hypothesis.

In conclusion, it would seem that there is no difference, in practice, between dictatorship and democracy. However, this would be incorrect: the difference rests in the fact that, in democracy, even though only “one” person decides, his choice is made legitimate by the community (which is not the case by definition in the case of dictatorship).

I would conclude that, even within the context of a classification of degrees of coercivity (lower in the case of a public decision, preceded by negotiation between the social parties, or taken within precise constitutional limits), the position of d’Albergo is rigorous in theory, while in practice it fails, which also concedes a point to J. Buchanan. Finally, the incomprehension between the two is explained also as a generational question (favouring or damaging both).

I also think that the theoretical vision is more successful than the practical one and not only in redistribution choices but also in allocative choices, and the reason for this is that “intentionally” allocative choices are also in fact redistributive. Allocative public choices, precisely, also involve benefits for some individuals and damage for others, by their own nature. For example, those who pay taxes higher in value than the services received in exchange have a negative balance, and those who

pay fewer taxes, of lesser value than the services received in exchange, have a positive balance. Even with these “redistributive” results, peaceful coexistence can be explained only because, already at the start, there is the “compulsory” acceptance of constitutional coexistence rules.

The “coercive” factor disappears only in the extreme, ideal model of M. Pantaleoni (described in the figure below) in which the community is configured as a single subject (as if it were a single individual, who corresponds to the organicistic theory of jurists). In this ideal case, in fact, taxation is equal to expenditure and the two elements relate to a single subject. Therefore there is no modification of the distribution, and the criterion of public financial activity leads back to the criterion of taxing and spending up to the point in which the marginal painfulness of taxation is equal to the marginal utility of public expenditure, as described in the following figure. From this the result is, on the basis of the hypotheses, that the optimal expenditure is G_1 .

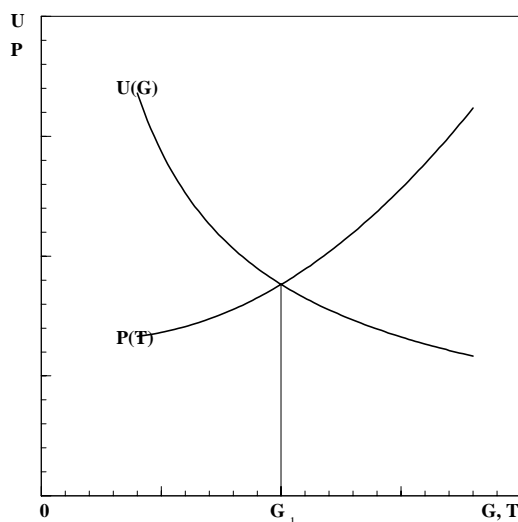

Therefore: U *marginal utility*, P *marginal painfulness*
 T *Taxation*, G *Public expenditure*, for $T = G$

c) Other limits of the “deviations”: towards the minimal State.

There are apparent errors of application of the model, which can be avoided only with extensive constitutional rules. For example, if *in applying the “second Paretian criterion” the distribution of income among social classes is modified*, and this leads to a shortage of investments to create development, the *same criterion* results ultimately in contradiction with itself, because the GNP (Gross National Product), which is the prerequisite to discussing distribution in future, is no longer there.

Furthermore, they are rather common considerations in the economic thinking of the past that, however, in recent times, have been directing economists towards a possible common “Welfare State” proposal²¹, in other words in a reductive sense. Ernesto d’Albergo was very aware of the limits of the Paretian model, even if indirectly.

In dealing with the principle of minimum collective sacrifice, expressed by Edgeworth, d’Albergo reminds us (sharing his concerns) that the “great mountain of economic knowledge” (as he called him), after expressing the same principle, was blurry with doubts and reservations: “a progressive tax, ... while it would improve distribution, would be an obstacle to savings and therefore to the increase in social wealth”. It is as if he was saying (our observation), that in future there will be no GNP to be shared, which is the essential prerequisite to discuss in terms of distribution in the future.

²¹ Various authors. (1981), *Il Welfare State possibile. Alternative agli insuccessi [The possible Welfare State. Alternatives to failure]*, in “Raccolta di saggi e interventi ad un Convegno della Fondazione Einaudi” [Collection of essays and interventions at an Einaudi Foundation Conference], Le Monnier, Florence, 1984.

In this he was supported by his great friend, R. D'Addario, who had expressed the “fundamental principle of taxation”, that “a citizen wealthier than another one before taxation could find himself poorer than him after taxation”. Clearly public expenditure also needs to be considered, observed d'Albergo to his friend²², and this also applies to Edgeworth.

What are the possibilities of applying the model without making a mistake? One of the lines of thought that we should remember in my view, is that inclined towards the *minimal* and *ultra-minimal* welfare State. We will refer to some of the numerous thinkers on these issues, such as Rawls and Nozick²³.

According to Rawls²⁴, a concept of justice is a set of principles that permits us to choose among different social assets, which determine a given distribution, allowing the formation of a consensus on just distributions.

The most rational concept of justice seems to be the “utilitarianistic” one: everyone, in striving for an advantage for themselves, can certainly balance their losses and their gains and therefore maximise what is good. This is the simplest and most immediate concept of what is subjectively perceived as just²⁵.

In precisely the same way as the principle that guides individual choice involves obtaining the maximum for oneself – striving to achieve as much as possible according to one's own system of rational desires – so the principle of social choice is that of achieving the maximum good, defined in the same way, obtained by adding up the good for all members of society, and so reaching in a natural way the “principle of utility”.

In the economy the needs of efficiency take the same shape as the Paretian optimum. It is a matter of a condition of “non-improvability” with respect to a given position that is voluntaristic and individualistic and therefore restrictive.

For Rawls the principle of justice needs first of all to be defined in a deductive way in itself, as a mode of not becoming trapped in simplistic formulations. Better still, there are “justice principles” such as the following ones:

- 1) Each man has the right to the maximum of primary goods, compatibly with the equal right of others. “Primary goods” are not only the provision of given goods and services but also fundamental freedoms for the growth of the person.
- 2) It is possible to accept inequalities in the distribution of incomes and of wealth as long as these inequalities do not contrast the need to guarantee equal opportunities for all and that they bring the maximum benefit to those who are less well off.

According to Rawls, human society is an association regulated by a common idea of justice with the purpose of favouring the welfare of its own members. Nevertheless, the social agreement reached is not so much the result of a “half way” compromise but rather an agreement among identical subjects, who automatically converge.

It is this that, starting from determined “value judgments” that we call universal, leads to the “minimal State”, in which the government is “ultra-minimal” (Nozick's concept, that is to say, it ensures the classic essential functions of the State, such as the protection of citizens, etc.) and also to conditions of sufficient competitiveness in market terms (no excessive concentration of property, etc.), a reasonably “full employment”, a social minimum through public transfers (family allowances,

²² d'Albergo, E. (1971), *Economy... op. cit.*, vol. I, p. 326.

²³ Nozick, R. (1980), *Anarchia, Stato e Utopia [Anarchy, State and Utopy]*, in “*Various authors* (edited by F. Forte/E. Granaglia), *La nuova politica economica americana*” [*New American economic policy*], Chapter 9, Sugarco, Milan, 1980.

²⁴ Rawls, J. (1980), *Giustizia distributiva [Distributive Justice]*, in “*Various authors* (edited by F. Forte/E. Granaglia), *La nuova politica economica americana*” [*New American economic policy*], Chapter 8, Sugarco, Milan.

²⁵ See this argument: Forte, F. (1993), *Teorie della giustizia e disuguaglianza [Theories of justice and inequality]*, *op.cit.* p. 283 and following; Zamagni, S. (1990), *Le teorie economiche della giustizia. Un contributo di economia "ingenua"* [Economic theories of justice. The contribution of “simple” economy], in “*A.A.V.V. Saggi di Politica economica [Various authors, Economic policy essays]*”, edited by N. Acocella, G. M. Rey, M. Tiberi, F. Angeli Publishing, Milan 1990.

special contributions in periods of unemployment, negative taxes on income) suitable for the satisfaction of fundamental individual needs, and in any case according to a continuous line in the correction of concentrations of wealth.

Therefore this means that while the market represents a fundamental reference point for the safeguard of the conditions of continuity of development, it also contains “deviances” that are so significant as to compromise its development: from this derives the concept of the *minimal State*, that is, a series of corrections which should “certainly” be applied, *but no more*, because going further along this line could improve but also worsen the situation with respect to the initial position.

However, it would seem obvious that these solutions, more than the rigorous solution of an allocation-distribution problem, are empirical ways of meeting, later, the needs of readjustment of economic systems in crisis, even if on the basis of perfectly respectable objective criteria (drop in the rate of growth in GDP, investments and employment).

5. Relationship between Pareto’s second criterion and Samuelson’s theory. For the revision of the current definition of public good as “identity”.

As has been observed already, the community as a sentient subject does not exist, as the community consisting of a single individual does not exist. Therefore there is no problem of the individual optimum in the context of the first criterion, but there is the problem of a collective optimum in the context of the second criterion. This position, often restated by d’Albergo, is in clear conflict with the position of Samuelson (1954).

This conflict is explained simply by recalling that the search for the optimum use of public assets is included by Samuelson in the model of the indifference curves, specific to the voluntary exchange. I will clarify that this approach with indifference curves is very different from that of the same Samuelson and of other well-known academics in welfare economy, which is based on a function of social welfare, and which d’Albergo had historically placed “after” the sociologist Pareto.

I have already recalled that, for welfare economy, the efficient use of private goods involves the equality between the marginal rates of substitution among the various goods, for all individuals, and these substitution rates must also be equal to the rate of transformation. This model by Samuelson, with indifference curves applied to “public goods”, involves radical changes with respect to the traditional financial theory.

To explain it, however, I must first of all recall another change that has taken place and more precisely the one relative to the definition of public good by Samuelson. As is known, he defined this as an “identity” and not as a “sum” (as for private goods): in other words a public item or service, once it is offered to someone in a given quantity, is available in the same quantity for *all equally* and *completely* and no one can be *excluded*. This means that there is no exchange of public goods among individuals so, for the optimal use of public goods, there is no equality between the substitution rates of the various individuals.

Instead there is only the problem of production and optimal use of public goods, to be achieved through the equality between the *sum* of the substitution rates of public goods of the various individuals and their transformation rate (that is, the equality between the sum of the “prices” that the individuals pay for the public item or service and its marginal cost). With Samuelson’s model we are in the context of voluntary exchanges, with public goods, in the sense that the realisation of the condition of efficiency means that welfare improves for everyone and worsens for no one, as in the context of the first criterion. Therefore, assuming that there exists a method to realise these efficiency conditions, it is not necessary to use coercion against anyone, because in fact the situation of everyone improves.

Therefore this theory, according to which the search for the conditions of optimum public choice does not presume a conflicting nature for public choices, logically compares, and rightly so, d’Albergo with Buchanan, the founder of the public choice school. Let’s look at this in more detail.

The contrast arises because the two visions start from two very different concepts of public item or service.

In my view, and I support of d'Albergo's position, Samuelson's definition of public item or service referred to above (the one defined as *identity*) is innovative compared to that in the previous literature, even though it is necessary to specify that this can be gleaned, in most cases, only in an implicit manner. In fact, Samuelson's definition does not raise the issue of the "division" of utility of public goods among the users for the purpose of getting payment on the basis of the individual benefit, if it is true that a public item or service, once offered to someone, can be *completely* enjoyed by everyone.

Also, this definition does not consider, in monetary terms, the problem of the distribution of the total cost on the basis of benefit, because every individual can use it (or uses it), a priori, in an equal way (that is to say, completely), and its use is objectively always a benefit if it is true that, in comparison to their total cost, every individual pays a very small proportion of the total cost. (The situation can clearly be different if it is approached in a subjective way, that is to say, in terms of utility, as enjoyed by single individuals.)

Conversely, all the previous literature had been concerned with the distribution of the cost of public goods on the basis of benefit, but had always "come aground" against the rock of the indivisibility of public goods. This means that the (current) "non-exclusion" principle was not a principle but a technical impossibility or an economic difficulty (in the sense that excluding someone was too costly, to the point of making the use of the public item or service inconvenient or impossible). Let's examine this further.

In the most authoritative Italian literature (*Giornale degli economisti [Economist journal]*) there was a long debate on the character of public goods (there is a detailed summary report of this in E. d'Albergo's *Economia della finanza pubblica [Public finance economy]*).

There was a discussion first of all about public goods and services in equivalent terms, and this was not insignificant because it meant, among other things, that "durable" public goods were to be taken into accounts for their services. For example, A. De Viti De Marco stated: "We call the goods that the State produces to satisfy the needs of the community *public services*".

M. Fasiani: "It is by now generally recognised that differentiating between the two economic categories of economic "goods" and "services" provided by the State is not only practically impossible but also quite pointless. From here we will use the two terms indifferently and interchangeably". "Like all writers, we will say that the State produces 'public services'".

Seligman does the same.

The same goes for the next generation, and among these we will recall Cesare Cosciani, up to the 1964 edition of his *Istituzioni di scienza delle finanze [Science of finance institutions]*, where Samuelson (1954) is generically quoted, and not with specific reference to his redefinition of public goods.

To understand this position it may be useful to remember what is normally done in political economy. It is customary to account for the physical quantities in the case of consumption goods that are consumed in only one way, and in the case of durable consumption goods we consider services. The same, as has been mentioned already, applied in the past for durable public goods.

In this analogous manner such public services were considered to be *capable of being added up* in the same way as private goods. I quote in particular Antonio De Viti De Marco because he is occasionally interpreted in such a way as to support a Samuelson-type definition. If we look into his *Principi di economia finanziaria [Principle of financial economy]*²⁶ we will find that in the case of

²⁶ 1934 Edition, Paolo Boringieri, Turin, 1961, p.36 and following.

private goods (bread) the need is given by the “*arithmetic sum* of their needs, individually felt by all consumers”.

On the other hand, in the case of public goods, “(their) collective need arises from a conflict of interests” and therefore it is “represented by the *algebraic sum* of positive and negative quantities”. (For example, the utility of police protecting private property is positive, while the utility of the police with regard to thieves is negative). I have also considered his 1905 *Lezioni di scienza della finanza* [*Lessons of the science of finance*] and I have found the same thing.

For further clarification I will recall that, normally, in programmes of public investments, parameters are adopted that measure the theoretical “availability” of each public item or service for each citizen. For example, if the programme is expected to build a defence system for 200,000 inhabitants, then the individual availability parameter is 1/200,000. In this sense the idea of public goods that, once offered to someone, are completely available to all individuals appears to be something absolutely unreal.

Of course there are extreme cases in which there is doubt but then, reflecting closely, we become aware that this is the result of a blunder. The case of the Polaris missile was used as a proof of this some years ago. In fact we were considering a technical event for a defence system, which had to be placed above a certain minimum to be considered feasible.

In relation to very small countries, such as Switzerland, a system of this type is unbearable in terms of cost, and it is in excess of requirements. For very large countries such a system (equal to the minimum) would be undersized. That’s all.

However, as mentioned above, the individual charge that “indivisible” services, such as those of general expenses (for enterprises with many products), might incur, is quite a different problem in political economy.

In the previous literature, the divergence between public and private services arose in fact on the grounds of “divisibility”, in the sense that, as general public services cannot avail themselves of market prices, there was no way of measuring individual utility of public goods and services on the basis of the differentiated demand of the various users, while it was possible to do so for private goods and services.

In turn, even the characteristic that meant that public goods could be considered at a zero marginal cost (in other words, the cost of an additional user of public goods is nil) could not represent a further reason to differentiate them from private goods, because “private” fixed costs were also at zero marginal cost (in comparison to production).

Someone makes the case of a single individual, affected by a contagious disease, to make the undeniable deduction that, if medical care is offered just for him, all others citizens would in any case benefit equally and completely.

In my view, however, not even light irradiates completely and instantly, equally for all, along long distances because its linear movement is deviated by obstacles, as it progressively moves away from its source.

In other words, the service against contagious diseases is “public” but it is also, normally, differentiated in terms of individual (but not measurable) utility. Returning therefore to the traditional definition of public item or service, the efficiency conditions for public goods are the same for d’Albergo as they were for the first Paretian criterion (in other words, balancing substitution rates for all consumers, etc.) but with the difference that in political economy the efficiency conditions can be achieved in the competitive market, while in public economy this is not feasible because of the lack of market prices and free individual demand.

In conclusion, with regard to this first issue addressed by d’Albergo, the optimum conditions with public goods and with the indifference curves as set by more recent literature (not by him) were outside the scope of very theoretical and practical logic.

6. About “functional finance”. Pre-Keynesian view and productivism of public financial activity.

Another vein of d’Albergo’s thinking is the significance given to the improvement of public expenditure, together with its collection, for the management of the economic cycle. Several studies come under this heading²⁷, one of which is from 1935, (*Sulla neutralizzazione della sensibilità congiunturale delle imposte* [About the neutralisation of economic sensitivity of taxes]), another from 1937 (*A proposito di “diffusione” dell’imposta* [About the “diffusion” of taxes]), another from 1939 (*Le nuove teorie economiche e il problema finanziario* [New economic theories and the financial problem]) and so on.

These essays consider the management of the public budget and of the loans linked to it for the neutralisation of cyclical events through the introduction of discontinuous flows of purchasing power, the distribution of the effects of taxes, and so on. These are concepts that are currently defined as the subject of “functional finance” (Lerner, Hansen).

In 1953, in returning to these concepts, he shared Griziotti’s wish, followed up later by F. Forte, that public expenditure be given the same attention in financial studies as is given to collection, and nevertheless he observed that he had already done so, even though it was necessary to continue on that path.

Similarly, with regard to the re-evaluation of this problem, in light of the macroeconomic approach, he observed that the consideration given to the problem was an issue of degree, and not of scientific novelty.

The formal aspect of this problem (which had been an interest of the Italian school for a long time) has its synthesis in the theory of the dynamic fiscal burden, with collection and expenditure. In other words, from a quantification of fiscal burden, referring to an initial period, and which contained in its numerator the collection (T), less “restitutions” to the community (V) (i.e. the value of the services supplied), and in the denominator the income (R), we move later to the quantification of the same, referring to a later time (second item of the inequality) so as to understand the effects of the development of income.

He observed this also with regard to Haavelmo’s theorem, which he wanted to validate but also relativise, in the sense that the increase in the national income, equal to public expenditure, should be considered “one” of the possible effects, but not the only one, among which there is also the possibility of a decrease in income, as a consequence of the public expenditure. He felt supported in these observations, among other things, by G. Stefani’s identical position. He expressed this position in symbols in his lessons in 1952 in this way, depending on the prevailing expansive or reductive effect on income. In symbols the expression was:

$$\frac{T - V}{R} \geq \frac{(T \pm t) - (V \pm v)}{R \pm r}$$

in case of worsening of development, or:

$$\frac{T - V}{R} \leq \frac{(T \pm t) - (V \pm v)}{R \pm r}$$

²⁷ “Sulla neutralizzazione della sensibilità congiunturale delle imposte” [About the neutralisation of economic sensitivity of levies], 1935; “Le nuove teorie economiche e il problema finanziario” [New economic theories and the financial problem], 1939; “Effetti delle imposte e teorie del “full employment”” [Effects of levies and theories of full employment], 1948; Una visione pre-keynesiana of fiscal policy [A pre-keynesian vision of fiscal policy], 1958; “In tema di “svolte” nella teoria della finanza pubblica” [“Turning points” in the theory of public finance], 1967; Contrapposizione razionale per lo studio degli effetti economici delle imposte” [Rational juxtaposition for the study of the economic effects of levies], 1952.

in case of an increase in development, where the small letters indicate the variations of T , V and R .

In his view, the aspects on the cycle compensation were necessarily integrated into the real effects that the public financial activity could have on the development of real income. In any case, it is known that additional public expenditure can be resolved in the increase of only monetary income, but not in real income, depending on the cycle's characteristics.

The 1931 and 1932 studies, (*Del principio produttivistico nei sistemi di imposizione personale sul reddito [The productivistic principle in systems of personal imposition on income]*) and (*Reddito e imposte. Saggio critico sul produttivismo nell'attività finanziaria [Income and taxes. Critical essay on productivism in financial activity]*), also relate to this.

In these essays, which have their root already in A. De Viti De Marco, the role of the State is defined as a factor of production for services and for infrastructures made available to the productive sector, but there is also a more rigorous, scientifically possible, approach to define this role in economic terms, a role that in his view can be summed up in the criterion of the participation of the State, as a factor of production, to the maximum production of the national income.

The scientific importance of the systematic analysis of the "productive" role of the State, which d'Albergo derived from A. De Viti De Marco, is understood by observing that it arises in an historical period in which (with the exception of the Soviet Union) the burden of public expenditure in Western countries did not exceed 30% of the GDP, and that E. d'Albergo had a liberistic approach.

7. About the weighting of "value judgments" in scientific analysis. Application of the contributive capacity: the tax on exchanges.

E. d'Albergo returned several times to consider what was, in his view, a significant concern from a methodological point of view. He believed that value judgments were not the pertinence of scientists. He therefore deprecated the role of those who, exploiting their scientific position, lavished advice on the formation of tributary systems. He saw the role of value judgment as being rationally placed in the context of synthesis, not of analysis, in the sense that to be able to give advice it was necessary to take into account the infinite elements that contribute to the determination of social phenomena. Furthermore, he had himself taken on this role but in respect of his position as president of A.N.T.I. (Associazione Nazionale dei Tributaristi Italiani [National Association of Italian Tax Experts]) in relation to fiscal reform in preparation at the time in Italy. And what is there to say about the "crisis" of the personal tax on income, which he considered in 1931, and which is still very current today? I believe that his methodological exactness deserves the greatest attention, in particular on the part of our young researchers.

Nevertheless, he clarified also the contact points between value judgments and scientific analysis. These concerned the issue that value judgments need to be taken into consideration as hypotheses, from which scientific consequences can be derived. To clarify: in political economy the trend of the curves of marginal utility is a working hypothesis, which the academic should not consider a verisimilitude. E. d'Albergo thought the same with regard to the distribution of taxes, starting from given hypotheses of trends and levels of curves of utility of the taxpayers' income. He returned to this question specifically in relation to his theory of the tax on exchanges²⁸, of 1931 and 1935, which was considered in the wider context of the differentiations between "absolute" and "relative" contributive capacity, next to the criterion of benefit.

Here d'Albergo, having observed that a tax on exchanges is a tax on gross receipts, (rather than a transferable tax on consumptions), explains that the taxation of gross receipts, more than the tax on

²⁸ I recall: "La natura e il fondamento dell'imposta sugli scambi" [The nature and foundation of the levy on exchanges], 1931; "Di alcuni effetti dell'imposta sugli scambi" [About some of the effects of the levy on exchanges], 1931; "Sulla "condensazione" delle aliquote" [About the "condensation" of tax rates], 1935.

the enterprise's profits, conforms with the need of the State to recoup its own production costs, in favour of the enterprise. In fact, if the tax on income applies, the enterprise that does not make a profit does not pay the tax, even though it may have used public services and infrastructures.

Someone had objected, with regard to this, that taxing gross receipts might lead to the possibility of also taxing enterprises without profits, and therefore cause them to fail.

However, according to d'Albergo, returning to the issue of value judgments, the scientific validity of a theory is one thing, and the opportunity of its application on tributary systems is another.

I believe that his scientific subtlety is exemplary. Furthermore, it is sufficient to think that it is commonly said about salaries, that they are privileged debts when compared to the profits to be attributed to proprietors. Why should the same thing not apply to taxes too? If the answer is that it should not, then it is a value judgment, which is not the remit of the academic. Or it is enough to recall the tax on assets, which applies to the taxpayer even if there is no income. What is the financial difference between capital and gross income? The difference is that capital is a current value and gross income is a rising one, and therefore they are two financially equivalent entities, by definition.

Still on this subject, with the objective of avoiding cascade taxation, specific to the general tax on exchanges at the time, d'Albergo suggested the "condensation" of the same tax (that is an average tax rate), which in practice is a method for neutralising this tax in terms of enterprises organised vertically and horizontally. Finally, we know that this issue was later solved across the European Union with the introduction of VAT (Value Added Tax).

8. Effects of taxes and public expenditure in a collectivistic system.

Another important issue for the general economic equilibrium is d'Albergo's study on collectivistic systems, which he completed late in his life. I will recall the 1966 essay on "Gli effetti di imposte e spese di bilancio in regime collettivistico" [The effects of taxes and budget expenditure in a collectivistic system].

He had been led to this by the study of Kretschmann Griziotti (the wife of the late Prof. Griziotti, his Master), and even earlier by E. Barone's essay on *Il Ministro della produzione nello Stato collettivista* [The production Ministry in the collectivistic State].

According to d'Albergo, the phenomenon of shifting, which would appear not to be an issue by definition in economic systems with controlled public prices, still exists in collectivistic systems although under false pretences.

He makes a long list of these examples. I will recall some of these:

- d'Albergo recalls, in the first instance, that in the case of collectivistic systems, not all private production is offered to public stores but, in fact, a part of this production remains with the private producer, who can sell it separately on the black market, which is tolerated. In this type of exchange the latent possibility of a shifting of the "real burdens" experienced by producers (in other words, the non-acknowledgement of profit, in the context of the transfer of stock) onto consumers is within the normal theory of economic equilibrium.

- There is also the systematic case of the balancing of deficits of given public enterprises with positive balances of other public enterprises. Also in this case the advantages in favour of some consumers (with the sale at a price less than cost) are paid by other consumers (with the sale at a price higher than cost).

- Another case is the formal modification of the distribution of incomes among members of the community in the course of salary negotiations, and also more generally with the balancing of the deficits of various State enterprises charged to the public budget.

- Another case is the exchange of money, which creates redistributive problems.

In other words, what is imposed by a “heavy hand” but which does not find correspondence in the effective power of economic agents, gives rise to a series of adjustments in individual equilibriums, with repercussions on the relationships between various individuals.

9. More specific subjects.

Finally, I will refer to some other issues (there would be many, to tell the truth) on which the originality of our Master can be measured.

a. - Amortization of public debt²⁹. The issue examined here is the utility of the rapid amortization of public debt, and d’Albergo’s conclusion that this represents the reversed Ricardian theory on the alternative between loan and extraordinary tax.

This is also an issue that is still very much current, also because, clearly, Italy has used public debt to excess, and not only in this historical time. Among other things, a publication from the Treasury reminds us these days that public debt greatly exceeded GDP in the first few years of the 20th century.

b. - Double taxation of savings³⁰. The discussion of the error of double taxation, inherent in the taxation of the income produced (remembering John Stuart Mill’s theorem), had given rise to a stream of publications (from different points of view: whether the tax modifies, in addition to income, the interest rate; whether the State production factor was economically entitled to its own slice of produced income, etc.). For d’Albergo, the issue was much simpler: no individual, having a capital at his disposal, would exchange it for a lesser one. Therefore, following the introduction of the tax, the gross return from the capital would have increased, due to the effect of market reactions, to a level such that, net of the tax, the difference between the capital before and after investment would have been eliminated.

He did not have any supporters at the time but recently in Italy (when State bonds were taxed) his forecast came true precisely. In other words, the Treasury, to retain the interest of savers, has had to correspond an interest rate gross of the tax such that the net interest rate is as before, when there was no tax.

I must add that, when Musgrave (in his *Theory of public finance*, 1959) later stated that the problem of double taxation of savings was a question of definition of income, d’Albergo declared himself in agreement with him. In my view, however, they were different issues, in the sense that for Musgrave, having assumed the “yield” (interest) as the income, double taxation had to be accepted as a consequence of the definition of income, taken as the object of taxation. According to d’Albergo, however, the double taxation arose from a financial point of view but then, in practice, it could not remain from an economic point of view, because the market would have compensated for it.

c - Tributary burden in international terms. Finally, I want to recall one of d’Albergo’s many scientific interests, which he rarely referred to late in his life, but which I want to remember because of the current interest in the problems of the fiscal harmonisation in Europe in view of the single currency.

It is known that the Rome Treaty (25 March 1957) envisaged the harmonisation of indirect taxes, because they have a potentially distortive effect on international commerce, as they “circulate” with

²⁹ I recall: “Nuovi studi sull’ammortamento del debito pubblico” [New studies on the amortisation of public debt], 1933–34; “Prestiti e imposte nelle nuove teorie finanziarie e nell’esperienza bellica” [Loans and levies in the new financial theories and in the war experience], 1945; “Brevi note sull’ammortamento e sui limiti del debito pubblico” [Brief notes on the amortisation and on the limits of public debt], 1955.

³⁰ I recall: Chapter VII of his *Economia della finanza pubblica* [Public finance economy], 1952; “Confessioni, convinzioni e conferme nella negazione del teorema della doppia tassazione del risparmio” [Confessions, convictions and confirmations in the negation of the theory of the double taxation of savings], 1971.

the goods. With regard to this, the prevalent opinion at the time was that countries with prominent direct taxes would have been advantaged, to the detriment of those which, on the other hand, had preeminent indirect taxes. Italy was among the latter at the time (and is still so today, although to a lesser extent).

However, d'Albergo asserted "the indifference of the factor represented by the different composition of tributary burdens in respect of the sale of products or goods when we move from various separate markets to a single unified market".

The thesis is based on the theory of the parity of purchasing powers of currency and how this hypothesises constant prices in a first approximation.

In brief, if it is true that the exchange between two currencies is established at a level such as to make the purchase of an item in one or the other country irrelevant and, if in one of the two the price is increased by indirect taxation, that exchange rate will neutralise the indirect tax.

Nevertheless d'Albergo specifies that the different direct and indirect fiscal structure is one thing, and the *diversified* indirect taxation, from goods to goods, within a given country is something else. In the case of non-general indirect taxation, the variance from the average is not entirely compensated for in the exchange, and yet this is not so much a problem of international fiscal harmonisation as an issue internal to each country.

Having said this, because the introduction of the single "Euro" currency, in place of the currencies of the various European countries, corresponds to the hypothesis of fixed exchanges now and forever, no new problem arises with regard to the structure of the fiscal system, because the adjustments have already taken place, and therefore the single currency continues the situation already established with the fixed exchanges.

All this applies as long as the exchange between the Euro and the lira is calculated correctly, which is not easy to do because it is not based on a pre-existing exchange market (between the lira and the Euro).

Not only, but once the single currency has been introduced, we return to a situation analogous to that in which gold was the international currency so that, in case of differences arising between the prices in the different European countries, goods and then the prices of the same goods in the various countries will also change, in case of a difference between them. Therefore, in case of changes of the indirect fiscal burden, there will be movements in prices, starting from those which are more exposed, in other words of those that are not entirely level today, in terms of purchasing power, because of greater divergences from the average fiscal burden.

This means that, in case of incorrect calculation of the exchange, a remedy will be the modification of the structure of the tributary system. For example, if the lira had survived, so that Italian prices in Euro were to rise in comparison to French prices in Euros (so as to lower the competitiveness of Italian goods, in comparison with that of other countries), it would be necessary to lower the tax revenue of indirect taxes with respect to that of indirect ones. D'Albergo did not say this but it is a corollary of his theory.

WARNING. The detailed list of Ernesto d'Albergo's publications, to which I refer in this introduction, is included at the end of this publication. I have edited and checked this list, also taking into account the contribution by his grandson, also by the name of Ernesto, Associate Professor of sociology at the University "La Sapienza" in Rome.

ERNESTO D'ALBERGO, ECONOMY OF PUBLIC FINANCE*

INTRODUCTION

I.

DEFINITION OF THE SCIENCE OF FINANCE
 AS ECONOMY OF PUBLIC FINANCE

The need for a definition of the science of finance is dictated by the logical need to coherently delimit the treatise with regard to what appears to be the scientifically understood subject of this study.

Philosophers tell us that a “definition” is the discourse we use to give meaning to an object. This therefore presupposes that we already have a certain notion of the object. The greatest difficulty lies in treating it in a concise and comprehensive manner: in such a way as to facilitate the prompt understanding of conclusions which presume specific lines of reasoning.

In these pages I will start to define the science of finance, understood as the preeminent and generally exclusive study of its economic-quantitative content, a definition which includes the issues that will essentially be covered in the current treatise, and therefore which is a concise programme statement that will explain coherently what will be presented to the readers in the individual units throughout this “course” of lessons.

R. A. Murray³¹ felt the methodological need, as other scholars had done, to “provisionally” define the science of finance as “the study of the common aspects characterising the financial activities of public bodies generally and the State in particular”. By “financial activity” he meant “activity carried out by public bodies to fulfil those needs which, at specific times and specific places, and for diverse reasons, they assume responsibility for”.

The task or objective of the science of finance as pure or hypothetical theory with economic content is “*the research of theoretical uniformity relating to the analysis:*

a) of the methods by which the State and lesser public bodies are able to, with or without compulsion, generate revenue and fund the expenditure necessary to meet public needs;

b) of the variations of specific equilibriums and of the more general economic balance caused by the methods and extent of collections and, generally, raising revenues and distribution of expenses, in the various market organisation hypotheses and the impact, or otherwise, of the time variable”.

In this “introduction”, which is *also* a methodological one³², and which intends to delimit coherently the scientific matter of this university course, the preceding definition may have some merit. It can be useful in clarifying the logical orientation of those interested in this science, which excludes, as far as is feasible, all factors unrelated to a doctrine that seeks knowledge and understanding of historical events, be they actual, probable or virtual, within the limits of observation of the quantitative aspects that have so far proven to be the most suitable for a scientific (economic) solution.

* The book is the translation of the original book in Italian. See: <http://amsacta.unibo.it/2571/>.

³¹ MURRAY R. A., *Principii fondamentali di scienza pura delle finanze [Fundamental principles of pure science of finance]*, Florence, «La Voce», 1914.

³² Methodology issues, which have unfortunately distracted many authors from exploring the implicit applications of such methodology, are intrinsically unproductive and the resolution to avoid them can only partially be adhered to in the course of these lessons. Almost against my will, I find myself compelled to consider these issues to try to put some order into the ideas which are expressed with such obstinacy by academics in this discipline, a discipline under which many diverse subjects are made to come under, in too insistent a way: economics, politics, law, technology. Some of these do so on scientific grounds but with clearly different criteria, or they may not be subject to theorisation, on the basis of our knowledge at present and probably for some time to come.

II.

SCIENTIFIC TREATISE FOR THE PURPOSE OF KNOWLEDGE ACCORDING TO THE DEFINITION

The definition does not presume that scientific research should, in the field of public finance, aim to find immediate application; that is, it excludes the formulation of *normae agendi*, suggestions, action plans, rules, etc. The primary purpose of the science of finance – intended as finance economics – is not to advise the prince or “squire” on how to administer public affairs for the satisfaction of the sovereign and of the subjects, or generally for the power of the State. None of this detracts in any way from what was expressed in the works of pioneers such as Petty, Justi and, in particular, Sonnenfels, at a time when the scientific bases of public finance were being established.

In other words, research has pure knowledge (and not financial *art*) as its objective. Academics and advisers have clearly different tasks, as we will see later, in being required] to separate rationally the economic from the legal or political aspects of the financial event.

The why of a financial event or of its expression in certain given ways, together with the analysis of the consequences of how and how much, belongs to science, that is, to pure finance theory, on which we focus primarily here.

The *should be* could, on the other hand, be disguised as scientific proposition. In fact hypothesis-based theoretical reasoning can hide behind formulations which *apparently* focus on the field of art or precepts. This differentiation between form and substance, in this comparison between art and theory, will be recalled later in the differentiation between economic and legal investigations of public finance.

The same can be said of the administrative rules or methods relating, for example, to the best, most convenient or appropriate method of collecting revenues: this also is a task which falls on the specialist, administrator or organiser of fiscal systems and sectors.

Some people refer to finance technology. We are in any case outside the scope of a theory which, as a scientific discipline with essentially economic content, considers administrative methods or systems as given when considering the solution to problems, for example *equal* distribution of the liabilities which give rise to public revenues. This is an (equal) administrative parameter or possibly also an ethical or political one, from which subsequently derive hypotheses and quantitatively expressed problems which can be treated almost in the same way as in exact sciences (mathematics and physics), with this known limitation: that the academic in this branch of social science cannot experiment but can only use observation as an approximate method of verifying deductions and theoretical uniformity.

III.

THEORETICAL PRINCIPLES GUIDING RESEARCH

Before examining other coherent consequences of the definition adopted in paragraph I, it is necessary to clarify that we refer to the statement of this definition identified with the letter (b).

Presuming positive action by active subjects (State or other public bodies), such as revenue collection, or negative action such as restitution or even renunciation of action (exemption from collection), etc., all conditions and hypotheses briefly considered here justify the use and application of various scientific principles.

As we are dealing with the analysis of variations of economic equilibriums and relationships, such as the impact of fiscal factors (taxation and public expenditure), we will therefore consider some guiding principles.

a) We refer here first of all to the *causality principle*, in the philosophical sense, intended as the connection, or relationship between objectively existing events. This corresponds to a relationship in the mind of the observer, which leads to a theory³³.

The *causality principle* should not be confused with *determinism*, defined as the existence of *necessary* connections, according to which “every cause has a determined effect and every effect has a determined cause”.

In the concept of cause we use the Aristotelian meaning of “effective” cause: that is, an appropriate force to produce an action or event or phenomenon.

We *cannot* however intend *causality principle* as understood by modern scientists, in the sense that in an experimental setting we can cause an event, *A*, at our discretion in order to observe its consequence, *B*. Finance events in fact are neither reproducible nor causable, as those taking place in the experimental laboratories of physical sciences may be. Public finance is not involved in causable events which lead to other events for experimental purposes. There is no single event that can be caused or produced at will for experimental purposes, such as the cause or “source of the wave” (as physics and mathematicians call it), which gives origin to an event. It is the wave which “diverges” from the source which becomes the cause. In physical sciences, events which can be provoked or caused at the discretion of the investigator are called *entropic* events.

b) Accepting the concept of *determinism*, in the sense that future events can be predicted on the basis of knowledge of present events, does not preclude the possibility that some relationships between events, which we consider here hypothetically, can be explained – always, however, on the basis that events theoretically analysed cannot be reproduced at our discretion.

When, however, even without being able to reproduce events in an experimental setting, we accept the concept of causality, not in the scientific but rather in the philosophical sense, we can *predict* that the action of a cause will lead to a specific effect. When the observed events are numerous (large numbers), the prediction of given events will be a certainty rather than a probability. By introducing a tax which impacts upon the cost of production, even when observing real, instantaneous events (which science considers hypothetical), a price increase variation can be predicted, in determined circumstances (low elasticity and cost-influenced demand for product).

But when, as we infer from the definition, a time factor is introduced and we move from a static vision (without time or duration of events) of causality relationships to a dynamic one (where events are considered in relation to their development and movement), the intervention of new and unforeseen causal factors weakens the deterministic connection, as an event is not the necessary consequence of an earlier one. Because of the intervention of variable “creative events”, predictions can only be perceived in terms of probability³⁴.

As we will see with regard to “a posteriori” measurability of the shifting process (that is, the transfer of a fiscal burden by means of a price increase or decrease, from a subject *A* to a subject *B*, *over time*), we can only assume it probable that the cost variation is a consequence of the fiscal event acting as a mass phenomenon within the market.

The analogy between physical and economic theory, limited to the study of the stationary movement representing economic life dominated by forces similar to inertia in mechanics, has been illustrated in the most dynamic and compelling way in L. Amoroso's³⁵ well-known publication, whose title is significant from this point of view. The failing of the deterministic character of movement in physics, on the basis of “Heisenberg's uncertainty principle” (according to which atom movement is considered dependent not only on forces, obstacles and resistance to inertia but also on elements unrelated to motion) has led to an analogous vision of dynamic theory relating to economics, in which actions are not repeated uniformly but present a continuous and perennial transformation: a constant becoming.

³³ PARETO, *Manuale, Introduzione* [Manual, Introduction].

³⁴ DEMARIA G., *Il principio di indeterminazione nella economia dinamica* [The uncertainty principle in dynamic economy] – Rivista Internazionale di scienze sociali [International journal of social sciences], September 1932.

³⁵ AMOROSO L., *Meccanica Economica* [Mechanics in economy], Macri, 1942.

c) With regard to the fact that we consider events and phenomena which cannot be reproduced or provoked at our discretion and which can only be observed, we must finally take into account another principle that we can consider as causal.

In a way, it could be said that this is, according to Aristotle, the meaning of “final cause”, which represents the objective, motivation or intent of the creative action, event or phenomenon.

I refer to the *finality principle*, according to which one phenomenon (means) is linked to another phenomenon (end). And as, in a vision dominated by the causality principle in the widest sense, there would be no effect without cause, without an end there would be no need for a means to achieve it³⁶.

d) Another principle that will find wide and frequent application, also in connection with the terms of the definition (which ascribes to the science of finance the study of variations in economic equilibrium), is that of *mutual dependence* between the quantities considered. The concept of “function” and its graphical shifting, which offers a visual representation of the variations linked to variables, will be widely used, as anticipated in the previous (1942, 1944) “prefaces” to this “course”.

As all quantities, in their reciprocal relationships, impact on each other in such a way that variation in one leads to variations in the others, we will take account of the relationship or principle of *general interdependence*, as well as a broader vision, with regard to problems that lend themselves to interpretation in this logical and wide context, without the limitations of the “*ceteris paribus*” clause.

It should not be necessary to warn that all the principles we have referred to can be demonstrated to be compatible with knowledge processes, typical of propaedeutic sciences, such as:

- 1) the *inductive* process (reasoning which moves from specific propositions to a general one);
- 2) the *deductive* process (starts from generic premises which are immediately evident and positive and leads to coherent consequences, through an ordered set of propositions).

IV.

EXPLICIT RATIONAL AND QUANTITATIVE CONCEPT IN THE DEFINITION AND “VALUE JUDGMENTS”

The definition of the subject of the science of finance, as the economic study of *quantitative* relationships influenced by financial events, leads us to exclude from analysis those factors which belong to a moral domain and are expressed in qualitative terms. What is just, what is good, and every other value judgment must be excluded from the thought process that is at the root of this science.

By excluding value judgments (just, good, etc.) from the subject of the science of finance, it might appear that there is a difference between those who use such value judgment to describe institutes and financial systems or principles, and those who abstain from expressing such moral appreciation.

I remember, with regard to *just taxation*, the following statement by Berliri³⁷:

³⁶ I refer to the original treatise by FANTAPPIÈ, applicable to the field of voluntary actions, such as those carried out by subjects operating in the economic field, like trends to ends, actions which are determined more by future ends than by past causes. In a field like economics, based mainly on psychological premises, it is not possible to ignore this principle when explaining events such as those we will consider later, for example: the trend of private taxpayers to maximum profit, compatibly with the interference of the fiscal event of tax collection; the trend to preserve income for own private use, “dismissing” the effect of a deduction of purchasing power as tax, etc. In Fantappiè’s view, our personality is motivated by ends and not by causes: we cannot ignore this principle in explaining the behaviour, particularly of individuals, with respect to hypothetical financial events. For the development of this theory refer to: Fantappiè, *Principii di una teoria unitaria del mondo fisico e biologico [Principles of a unitary theory in the physical and biological world]*, Rome, «Humanitas nova».

³⁷ BERLIRI L.V., *La giusta imposta [Just taxation]*, Rome, Istituto Italiano di Studi Legislativi, 1945.

a) economists (“and politicians”) are in agreement when thinking that their science should not be interested in the justice, or lack thereof, of taxation.

b) economists, politicians and jurists come to the conclusion that there is no “just taxation”.

These propositions are not methodologically admissible. In fact they do not clarify the position of the academic with regard to those ideals of justice, welfare, etc., that dominate practical and political solutions.

I do not understand why Berliri has placed “politicians” alongside economists and jurists when in fact it is only politicians who are able to, and often do, pronounce value judgments in their role as action people, as opposed to academics.

Given a definition of “justice” or of what is “good” in a financial context, the financial economics expert analyses the extent to which institutes³⁸ correspond to it, highlighting which consequences derive, in quantitative terms, from accepting the definition or the concept of “just”, “good”, etc. When it is said that “the economist will therefore need to come to terms with this need for justice”, we respond by saying that economists, the real experts in this science, have “come to terms” with justice as an ideal set by politicians, whether it is canonised or otherwise in the laws to be implemented in the field of taxation.

Let us suppose that justice is defined as equality in terms of the position of community members with regard to payment of tax. With respect to this hypothesis, the financial theory expert will consider whether this equality, in objective (monetary) terms is rationally translated into a proportional collection of income or wealth in general; if this equality is intended subjectively (a sacrifice of the usefulness of wealth owned), it will explain if, and in which circumstances, proportional and progressive taxation respectively coherently satisfy the non-scientific premises of justice and equality in terms of paying tributes to the State.

What should be said of those who believe that the concept of justice has not been taken into account by economists, when we think of two of the greatest minds (Edgeworth and Wicksell), leading rationalists and among the most rigorous thinkers of the end of the nineteenth century and the first quarter of the twentieth, including the research tools they employed? Edgeworth³⁹ used the heading *Principle of taxation justice* for the second part of its treatise, *The pure theory of taxation*. Wicksell⁴⁰ dedicated the second of his well-known *Essays of theoretical finance* entirely to the illustration of *A new principle of just taxation*.

It certainly seems strange that Einaudi⁴¹ himself did not observe that economists have “come to terms” with the concept of justice since the scientific resolution of this discipline in the economic sense. In fact, he was the one who drafted a critique of the correlation between this concept of justice, translated into that of equality, and the abstract systems used to express this concept, in the field of taxation enforcement. Such abstract systems have also been speculated about by financial economics experts through criticised “greatest utilitarian principles”.

The concept of taxation justice, appropriately defined as “pre-judicial” by Allorio at the start of his treatise, pre-exists for the jurist and it is “the one to which reference is *most frequently* made by economists”. He continues: “In the end, taxation justice in the sense that is relevant to jurists is no other than the extension and realisation of taxation justice as intended by economists”. It seems strange that Berliri did not observe this, as he will certainly have considered it when examining *Taxation procedural law*⁴², and even more strange that Einaudi did not think, when dictating the

³⁸ Methods and extent of revenue collection, in particular in the field of taxation: that is, coercive collection by a public body, with simultaneous consideration, or lack thereof, of the benefits and the usefulness of public services received.

³⁹ EDGEWORTH, “Teoria pura dell’imposta” [The pure theory of taxation], *Biblioteca dell’Economista*, vol. XVI.

⁴⁰ WICKSELL, “Saggi di finanza teorica” [Essays on theoretical finance], *Nuova collana di Economisti [New collection on economists]*, vol. IX.

⁴¹ EINAUDI L., *Miti e paradossi della giustizia tributaria [Myths and paradoxes of taxation justice]*, G. Einaudi, 1938.

⁴² ALLORIO, *Diritto processuale tributario [Taxation procedural law]*, Milan, Giuffrè 1942, pp. 16–17.

preface, of his own formal and frequent reference to concepts of justice, making only indirect mention of his own treatise on “good” taxation⁴³.

Having said that, if “just” or “good” taxation is defined as the one which least disturbs the balance of exchange relationships, that is, the market equilibrium, the theoretical finance academic will observe conditions which need to occur in the distribution of taxation to ensure this definition of taxation is coherent, in qualitative terms, to that which is scientifically analysed. Clearly the conclusion may be that, as all taxes affect the economic balance in quantitative terms, the psychological effect of determinate ways to distribute taxation may give rise to generally greater or lesser, additional or differential disruptions of market equilibrium.

If “just” taxation is defined, in the context of policy or in any case outside of a scientific or ethical context, as the one that approximates the price which would have been *freely* paid had there not been the coercion associated with taxation, the academic will hypothetically configure the logically adequate productivity conditions of the taxation destination. These will be such, in the context of distribution of revenue to different items of expenditure or investment, that the taxpayer will endorse, compatibly with his own maximum satisfaction, such distribution of available revenue and wealth to those public and private purposes which he freely adopts in meeting his own needs, in accordance with market prices.

The same academic will scientifically demonstrate, through pure reasoning of course, that it is inconceivable for taxation to correspond, even approximately, to market prices and will therefore negate from this point of view, that is, through logical reasoning, the possibility, however hypothetical, of configuring such good or “just” taxation by means of logical contradiction, for example.

But this does not mean *formulating* “a priori” value judgments, which have a role in the moral context, outside of science. It means *taking into account* definitions drawn from an ethical and political context to extrapolate characteristics (type of taxation or public prices) and quantitative consequences of accepting the premise of a *given* definition of justice, for example taxation justice, to find a logical solution to the problem, for example in terms of distribution of taxation on the basis of *given* ethical principles, and in accordance with them.

Although the formulation of scientific propositions can deceive the pioneers of this science, it is clear that essentially the methods used were no different from the one I have used here, with respect to the role given to value judgments in the scientific field.

Take, for example, one of the first “professors” of science of finance, S. Majorana⁴⁴. In explaining exchange theory, after discussing the “inequality and injustice of taxation distribution”, he

⁴³ EINAUDI L., “Contributo alla ricerca dell' ‘ottima imposta’” [Contribution to the research of “good taxation”], *Annali di Economia dell'Università Bocconi*, Milan, 1929.

I had written these notes, in 1945, for the most part in the margins of the pages of the late Berliri’s work, so immediate was my reaction to the declaration of lack of consideration for the concept of justice by economics and science of finance experts, when I became aware of the position similarly taken by GANGEMI, *Elements*, previously cited, in 1948, pp. 409–10. To the concept of justice he adds the concept of universality of taxation duty.

But universality engages jurists more so than economists. The collapse of privileges and the subjugation of citizens to taxation law have affected statutes and constitutions, interpreters and organisers of constitutional and public law much more. Economists are interested in the *exceptions* to the principle, with the study of the effects of fiscal exemption as Gangemi also recalls, if they are in favour of titles of public debt, and the revenues and capital values associated with the most varied forms of economic activity. And universality has been enshrined in taxation regulations, which are defined as “administrative” and yet are rich in economic content for aspects *other than* universality. This has, on the other hand, been of profound interest to economists with regard to *generality* in terms of imposition of taxation burdens. Generality, however, recalls the concept of burden uniformity, which is idealised and actuated by means of proportional taxation. And this takes us back to the concept of taxation equality as a concept that has fascinated and continues to fascinate, in objective and subjective terms, the minds of rationalists who also start from the concept of justice as expressed by politicians and moralists throughout history.

⁴⁴ MAJORANA S., *Trattato di economia politica [Treatise of political economics]*, 3rd edition, 1912, chapter VI.

refers to “the justice of taxation” as productivity of employment; and “with respect to the individual”, “justice lies in the comparison of the sacrifices endured as a taxpayer with the direct and indirect advantages obtained by the deployment of taxation”. Majorana believes that the “shortcoming of uniformity or the diversity of the taxation system” is a violation of the principle of “equal distribution of taxation”. He states that equality in taxation translates into proportionality as well as universality, and quotes others (Mill, P. Smith) who demand proportionality in the services received by taxpayers; he does not deny “the equality of the principle of progressive taxation”; he agrees with Stuart Mill (who believes that progressive taxation is “part of justice”) and he cites Say who states: “progressive taxation is the only fair taxation”.

This anthology demonstrates how it is possible for value judgments, and their shifting in systems coherent with the definition of justice, to *appear* to be confused. It does however confirm, for now, that economists have been “taking into account” concepts of justice and equality for a long time. Even now, these definitions can represent starting points, premises, concepts or definitions which the theorist accepts with the purpose of considering the scientific issue of correspondence of taxation and expenditure distribution systems to such premises, definitions, etc. when they are considered at the same time. All this for the coherent solution of problems of distribution of taxation appraised by ideals which are, *of themselves*, outside of science, or considered as given, preliminary conditions or premises which the theorist takes into account for their corresponding hypothetical construction. *There is no confusion*, therefore, between science and life or history, between ethics and economics; there is, however, *correspondence* of economic and financial logical systems to *given* definitions or ideal conditions, formulated by the politician and whoever needs to solve social problems by taking also into account moral elements, with a modern methodology for this science that reflects, including in its form, the precepts relating to the theorist’s task.

With regard to *confusion* of different elements, both moral and rational ones, I make reference to a Swedish academic.

The work by Myrdal⁴⁵ has been favourably received in Italy: in my view, without justification. In this the author undertakes to identify systematically the insinuation of the political and fideistic element or that of regulatory premises in economic theories. In particular Myrdal focuses critically on the science of finance, but he often contradicts himself.

In fact, he clearly considers (p. 21) the investigation of pure theory in the field of science of finance (having “points of contact with practical policy”) to be sterile, and then, at the end of the treatise, he declares the doctrine of *incidence* in the wider sense and the doctrine of the possible effects of fiscal systems to be the only content of all science of finance (p. 307), not noticing that what he suggests is in fact investigations of pure economics theory.

I have made reference to Myrdal as a representative case of a mentality averse to “the highest utilitarian principles” or to reasoning based on hedonistic premises (we will later consider the legitimacy of this in a hypothetical setting, such as the scientific setting), to remind us that criticism of this type (which confuses history with science, the fideistic political element with the consequences of reasoning deriving from premises that the theorist accepts as *given*) does not benefit the progress of our discipline.

V.

RATIONALE OF THE DEFINITION STATING THE LIMITATION OF THEORETICAL RESEARCH WITH RESPECT TO ECONOMIC ISSUES OF THE PROBLEMS OF PUBLIC FINANCE.

By trying to understand the division of tasks between moralists and scientists, those who shape moral and political ideals and those who seek financial systems or individual financial institutes that correspond to and are coherent with them, we get closer to an understanding of the complex

⁴⁵ MYRDAL, *L'elemento politico nella formazione delle dottrine dell'economia pura [The political element in the formulation of doctrines of pure economy]*, translation for Biblioteca Sansoni:

nature of the financial phenomenon. *The definition resolves the issue of the quantitative content of the science of finance by limiting its remit mainly, both implicitly and explicitly to the economic field.*

With regard to the relevance of my position, allow me to refer to Taylor⁴⁶, the talented expert of public finance in the United States, whose methodological concepts are reflected in the relevance of the titles of the respective volumes. He states in fact that the field is so wide and deep that the solution of the fiscal problem requires the “co-ordinated effort of various *specialists*”.

An orthodox vision such as this does not, unfortunately, appear to be evident in Italy, where rigorous and esteemed studies in the pure science of finance have thrived, judging from the statements and positions which follow, and which deserve to be criticised in the sense indicated in previous editions of these lessons.

When considering the rational ideal of the desirable⁴⁷ separation of the two teachings (separation that has already taken place by disassociating political economy from commercial law, which used to be taught together), it is nevertheless necessary to restate the clear separation, at least in a scientific setting, between the science of finance, financial law and other disciplines that can help explain financial events (financial policy, administration technology, etc.).

Texts by academics in the science of finance and financial law continue to create confusion between:

a) on the one hand, theoretical analysis for the purpose of *scientific research* in the fields reserved respectively for the two disciplines under the heading of the science of finance (whose content is quite vague if not restricted to financial economics, to the point that Zingali suggests that this “science” should also include financial law); and also *analysis*, still in a theoretical setting (according to a process shared by all sciences, even the most sophisticated and exact ones), which requires the separation, for the purposes of study and scientific construction, of aspects presenting specific sets of tangible phenomena, and on the other:

b) *synthesis for the purposes* of university teaching, in the sense that the illustration of the two fundamental aspects on the basis of which the financial event has been studied mainly up to now is assigned to a single lecturer;

c) *scientific synthesis*, which we have yet to see in a truly adequate form, and may not be able to see from any individual academic;

d) *synthesis for the real purposes of interpretation* of positive legislation, that is the explanation of institutes, systems, etc., that give substance to a given set of actual phenomena.

Furthermore, legislation and law are alternatively and indifferently used where, if anything, the correlation between scientific arrangement of reality and the pure and simple representation of reality should be made clear.

If we were to follow this direction now (when the position of sciences with regard to the various phenomena is understood in the scientific world, which includes the various disciplines), this would give rise to a conflict and, finally, to a regression in the field of financial theory. We need therefore to differentiate between positions which are ultimately erroneous, which I summarise here, and the rigorous scientific criteria that the study of financial economics and financial law must adhere to.

A) It was possible to read, for example, in a very recent methodological essay by Zingali⁴⁸, statements like the following ones, dictated by real necessity, which the reader will perceive are not

⁴⁶ TAYLOR PH. E., *The economics of public finance*, New York, MacMillan, 1948.

⁴⁷ Also according to A. D. GIANNINI, *Rivista Italiana di diritto finanziario [Italian Revue of financial law]*, 1939, n l.

⁴⁸ Included in the volume, a credit to Prof. TIVARONI, *Finanza pubblica contemporanea [Contemporary public finance]*, Bari, Laterza, 1950, in which, as we have seen, he reports ideas that had been much more cautiously expressed in *Lezioni di scienza delle finanze [Lessons in the science of finance]*, Catania, Muglia, 1947, in which the *practical* or educational and academic issue was given priority. On p. 26, in fact, he suggests to those who aspire to teach the science of finance, that is to newly qualified “tomorrow’s tutors”, to “start to set

compatible with the stance a scientist must take, as I will prove with further methodological statements that will follow further on.

After making the extreme case in terms of definition, as mentioned earlier, of a science of finance that “embraces *all* aspects that can be scientifically analysed with regard to the financial phenomenon” (and this *theoretically* as well as *educationally*), Zingali praises E. Vanoni’s course in two volumes that “offers a plastic manifestation of the *mixed* content of the discipline” (that has become a single entity in spite of the fact that both economy and law are covered). This course, according to Zingali, should not only “choose a model” (from the many which come under the official scope of our subject) “but also practice it in a truly scientific and uniform way, as Benvenuto Griziotti has persistently maintained”.

I will not stress to what extent this suggestion is against best tradition and scientific methodology. I will limit myself to demonstrating this point using the position of scientists in all fields from the past and the present and the same concepts that Zingali himself supported some years ago.

As it happens, Zingali states that the real finance expert cannot disregard the law (and uses this term instead of legislation) that gives substance to hypotheses of pure theory or allows these and the deductions scientifically derived from them to be verified.

According to Zingali, financial economics and financial law should not only be used in coordination but should also be “fused in the analytical and synthetic examination of the issues” so as to “build financial law on economic grounds and financial economics on legal grounds”. “Only if academics can be economists and jurists at the same time will financial economics and financial law find, in a university course, their definitive connection”. It would be the complete triumph of the “mixed” specialisation.

It is amazing how Zingali, gifted with great intellectual equilibrium, managed to change his mind so quickly, in the space of only two years. In fact, in the 1947 edition of “Lezioni di scienza della finanza [Lessons in the science of finance]” (Muglia, Catania), he declared (p. 24) not to want a “scientific mingling of different disciplines”: a mingling that has been clearly demonstrated in the logical confusion we have seen in the past and which still currently characterises the approach to theoretical issues. However, after correctly recognising that the disciplines “do not cease to exist individually as economics, law, politics and technology (and therefore continue to be autonomous from each other) even if they refer to the same (financial) field”, he became aware of the “enormous difficulties from time to time facing the unfortunate mind attempting such a synthesis”. Zingali had observed as much to Griziotti who, talking in the plural, had defined himself as one of the “complete financial experts⁴⁹, at the same time an economist, politician, jurist and technician”, by gallantly observing that “one swallow does not a summer make”.

up their preparation of both senses”, i.e. the juridic and economic ones, “ignoring any conceptual preference and by taking into harmonic and proportionate consideration all four elements that constitute the subject”, that is also the political and technical aspects.

This means that the knowledge the “tutor” will impart in his academic lessons should include an understanding of these subjects. The “tutor”, however, should not passively repeat notions that derive from the research of others, rather these concepts should be critically recollected with the mind focused towards a single order of logical reasoning.

On the other hand, we talk in these pages of scientific *creation* or *construction*, of a study striving, through original individual or respective contributions, towards theoretical uniformity for the advancement of a rationally developed science.

⁴⁹ It is possible to get an idea of the difficulty involved in this scientific synthesis by reading what, according to C. GINI’s *Alle basi della scienza [At the root of science]*, in *Studi di memoria [Study in memory of G. Masci]*, vol. II, published by GIUFFRÉ in 1943, is the “programme” of an *Integral economy*. This encourages us “a priori” to abandon the idea of starting on such a task, precisely when the trend in science is towards greater differentiation and specialisation in analytical thinking. It is sufficient to think in terms of “a first introductory section” that would cover “the general laws of sequence and coexistence that link economic phenomena to phenomena studied in other sciences” such as demography, ethnology, biology, psychology, etc.: it could be viewed as a sort of “Economic General Sociology”.

I don't know what academics abroad might make of such suggested "mixed" specialisations, which do not have any place in the current scientific field. I am referring to academics from abroad who pay to Italy the respect due the rigorous organisers of a discipline based more on treatises than essays, thanks to its academics in the science of finance, that is, its economists. Those of us who try to follow the way the world thinks and writes about a single sector in economic science, and who try to keep up with the kind of progress that specialisation continues to encourage, can understand how a programme of scientific work (like the one whose characteristics we have commented on) is outside the realm of possibility, or rather the competence, of who really intends to carry out scientific work and not simply serve a medley of someone else's scientific achievements.

B) Another type of confusion is that apparent, again in recent works⁵⁰, in Griziotti's argument, which we should keep in mind when we highlight what rational as well as non-scientific thought it contains.

From this second point of view, and in connection with the recently published compilation by Zingali, which also reflects the view of other authors, it is still contrary to the predominant methodology in the science, especially in those sciences that are mainly analytical, to state as Griziotti does:

a) that "functional study" should consider (in the context of science construction) the single constructive element of each public revenue (the politician is not necessarily a basic definition but rather a complex economic, juridical and technological concept⁵¹). This, my interpretation of scientific synthesis, the work of the same academic, is not an arbitrary extension of the thought of this author. In fact he states that functional study directs "the general theory of finance" to research and elaboration up to the ultimate consequences of political, socio-economic juridical and technological "general principles". We would be heading, that is, to the "coordinated synthesis of the four principles". And to continue with this synthesis "we must be jurists as well as economists".

I will not insist in deriving the concept of sciences, which sees the ideal of synthesis getting further away rather than closer to us (through logic and necessary specialisation), in the work of a single academic: synthesis is not a *destination* but a *starting* point and, as such, it characterises the first stages of scientific achievement.

But I must admit that, if not for the confusion between creation and construction of science and its application in the multiple aspects in which it has been developed, it could be possible to accept what is correct in the vision of the so called functional interpretation of financial laws. It is in fact true that to understand and explain *real* laws and institutions, it is necessary *in practice* to use all the disciplines which have contributed (separately and with their own methodological approach) to illustrate the issues in question.

It is true that a legislator who wants to achieve specific complex objectives must keep in mind the various aspects involved in the *taxation* event. It is true that to *interpret* laws and to illustrate its

Various branches grow "from this common root". Gini lists *three* and one of these, *Deductive economics*, further divides into *six* sub-branches. As it can be seen, the difficulty of intellectually embracing such extensive knowledge not only becomes clear, but the unavoidable need for differentiation and specialisation in the *context* of such *integral* economics is also confirmed.

⁵⁰ *Rivista di diritto finanziario e scienza delle finanze [Revue of financial law and of the science of finance]*, 1949.

Philosophers also warned us that "the abstract schemes of economics, insufficient in containing the richness of *reality*, offer nothing more than a tool to those embarking in real historic and sociological observation and who need many other instruments at the same time". CROCE - *Filosofia della pratica [Philosophy of practice]*.

⁵¹ See the article by E. D'ALBERGO on the contradiction of those who compare the "political" element to other elements in the financial phenomenon, believing that this contributes to the analysis, whereas "political judgment is still a *complex* judgment and in any case with a meaning that is not rigorously defined by those who use the term in a discriminating way": *Sulla scelta e sul contenuto economico dei sistemi giuridici di ammortamento del debito pubblico [On the choice and economic content of judicial systems in amortisation of public debt]*, in "Giornale degli economisti" [Economists journal], August 1934. The reference here is incidental but it is fitting from the point of view of interest to us here.

intent it is necessary to apply the elaborate principles of the disciplines that (separately and through analysis) study the financial phenomenon⁵².

It is true that law interpretation can be facilitated by the consideration of multiple aspects from which the why and the how of the organisation of specific norms may be determined. It is true that it is easier to gain a deeper understanding of financial *laws* with knowledge of the science of finance and financial law. It is in fact for this reason that the two disciplines are needed, but only if they are rigorously taught by specialists in the two disciplines. The reason for this is that we do not know of any experts in the mixed sciences who have risen to the reputation of scientists, a definition used in the sense commonly applied to the various branches of knowledge to characterise the real creator of the science and not its, more or less able, distributors. All this however:

a) deals with the *application* of disciplines;

b) brings us to the domain of practical synthesis, which is appropriate in the immediate consideration of the *reality* in its complexity. In other words it refers to the real task of the interpretation of reality, with *practical* objectives such as the ones a judge might consider, and not to the creation of theoretical instruments for the analytical explanation of aspects of phenomena. In fact the relative analyses are *presumed either* to be in place or the result of the work of all those who have contributed to the progress of the science, when the interpreter wants to *use and apply them*;

c) in particular it does not constitute a novelty because for a long time many, for example, those who have attended my courses on the science of finance, have known that economics and law contribute to the understanding of the financial phenomenon, for the different aspects resulting from specific laws.

For a long time I have commented on or *indicated* factors which combine with the (economic) subject under study, without the pretension of originality in the methodology used in the *interpretation of facts*, following De Viti in some points (and using typical examples, after applying the results of financial economics derived from in-depth investigations).

It is possible to follow such a path to indicate the complexity of *concrete* problems or the *historical* solutions to such problems (and therefore of the corresponding fields of study which become accessible to those who are interested and able to examine, from other theoretical points of view, problems we are interested in here from an economic point of view). However, as I have already stated in the previous edition, *indications* of this type do not imply proceeding to a scientific synthesis (pp. 24–25 of the 1944 edition).

Please refer to Murray's attempt, if interested in this sort of methodology. After making complex observations (examining financial activity in two "parts", from the political and economic points of view respectively, for the determination and satisfaction of public needs), he moves to a process of synthesis of previous research, trying to highlight the connection or the inseparability of public revenue and public expenditure. It will become apparent how this "synthesis" does not add

⁵² The thinking of an orthodox jurist such as Giannini supports my argument, which is reached independently as an obvious theoretical necessity and is confirmed by my academic experience. In the article, previously quoted, in the *Italian Review of Financial Law*, 1939 [cit], he perceives the confusion between "scientific methodology" and "financial law interpretation" and states: a) whoever conscientiously exercises the role of judge or lawyer feels the need every day to get a clear impression, for the resolution of a juridical question, of data and issues relating to the most varied disciplines, be they physical, chemical, natural, comical [*sic*] or accounting ones; b) the inclusion of the actual event under the most relevant regulation requires subtle investigation to determine if, and to what extent, it is possible for the interpreter to go from the letter of the law back to the concept that shaped it, or to apply it in an analogical way to a type of event different from the one that had been assumed it was intended for. This is a problem that is essentially and exclusively a juridic one, which is not at all peculiar to fiscal law, although in this field it takes on characteristic aspects. For its resolution it is possible to use elements drawn from economics as well as, to a greater extent, from private law but only as given facts which might be opportune to keep in mind in the reconstruction of the thought contained in fiscal regulations, without the transformation of a fiscal law issue into an economic or private law one.

It is also a problem that, like any other relating to the interpretation and application of the law, that needs to be resolved on a case-by-case basis, through the skilful use of common criteria of law hermeneutics, etc.

much value to the two analyses which remain side by side, or in juxtaposition of their respective results, applied to the two categories of action of the public body. (*Principii fondamentali di scienza pura delle finanze [Fundamental principles of pure science of finance]*, previously cited).

It is, however, necessary to go beyond the field of the science of finance and look to the scientific process in other domains of knowledge.

We can generally determine from the following quotes, which demonstrate theoretical unity of vision and which tap into various branches of science, what the scientific analytical position is of those who seek uniformity or norms:

– Let the mathematician speak and he, for example Poincaré (*Science et méthode [Science and method]*), will warn from the start that the scientist, for whom it is more important to observe well rather than observe all, will need to choose which events to observe. He might choose *simple* events, with characteristics of real simplicity, which are more likely to be encountered on their own or as *elements* in a complex set.

– Talking about pure logic, among other things Enriquez admits that “the synthetic view of knowledge, which is convenient in the common sense of aiming to its objective, is often contrasted by the analytical view of science that, by breaking down a set into its component parts, evaluates each one in isolation”⁵³.

– The modern physicist will express himself in a similar manner when he tells us (for example, De Broglie): “More or less schematic idealisations of our spirit may represent some aspects of things, but they are limited, and they cannot contain all the richness of reality in their rigid schemes.”⁵⁴ And also (for the description of physical entities): “We construct models and concepts, inspired by our daily experience. From this experience we remove some aspects; and by simplifying and extracting we form simple images, apparently clear concepts with which we attempt the interpretation of phenomena ... it is possible that these idealisations (as Bohr calls them) are simplistic products of our reason, and therefore cannot be applied exactly to reality. To describe the complexity of reality it may therefore be necessary to use successively two or more of these idealisations for the same entity.”

– The contemporary methodologist⁵⁵ states that the “scientist abstracts because he *breaks down* the object into its definite characteristics and examines them one at a time, in quantitative terms”. “A scientist can study a crystal in many different ways. Geometry, physics, chemistry, mineralogy, geology, spectrography and other sciences can also be interested in crystals, but each one isolates and examines some peculiar characteristics in quantitative representations.” As we are interested in theoretical analogy, we recall the concept that resonates with the same Baldacci who believes that, in scientific methodology, abstraction means nothing other than “isolating and quantitatively representing one or more aspects of the phenomenon”.

We appear to be going back to when Cairnes was compelled to make methodology clarification when faced with the claim of A. Comte, that all investigations in the structure and the laws of society were based on the principle of treating social events as a *set*. Comte believed that society should be studied in the totality of its elements, and no investigation should be undertaken on any part of these elements, other than in constant connection with parallel investigations carried out at the same time in all parts existing in the overall set. To this, Cairnes responded: “Rather than proceeding according to a methodology which considers the *set*, that is, to study all elements of society at once, the economist proceeds according to the opposite rule. He breaks down the overall social phenomenon into elementary groups that make up the whole and, choosing one of them, studies it separately from all the others”. Cairnes further clarifies: “He truly does not confuse the norms he derives in this way, the norms of the detached group, with the norms of society.”

To demonstrate to young people that *specialisation* is the true way of science, I recall Menger (*Il metodo nella scienza economica [Methodology in economic science]*) when he points out that:

⁵³ *Problemi della Scienza [Problems of science]*, ZANICHELLI, p. 89.

⁵⁴ *I quanti e la fisica moderna [Quanta and modern physics]*, EINAUDI, pp. 17–18 and 229.

⁵⁵ BALDACCI - *Del metodo nella Scienza [About methodology in science]*, BOMPIANI, 1947, pp. 70 and 125.

– “Not a single theory but the overall set of theories about human phenomena, *once they have been elaborated*, may (also using the results of the realistic approach) give us an understanding (as far as the human spirit can reach) of social phenomena in their full empiric reality” (p. 45).

– And this, after having stated: “Not a single one of these sciences (which give us exact laws on phenomena) gives us the knowledge of reality in its empiric complexity, but only some aspects of it, and therefore they cannot be judged in the same manner as empiric realism. We must, however, keep in mind that this overall complexity allows us as characteristic and as deep an understanding of the real world” (p. 44).

– “Theoretical economics includes exact and empiric understanding, and there is no reason why it should *a priori* oppose a separate treatment of these two sets of knowledge; it is possible to imagine in this way a separate treatment of exact knowledge (exact economics) alongside a treatment of empirical knowledge and of the laws underlying the historical development of economic events, in particular the law on large numbers, etc.”

There is a great apparent *practical* interest in treating all real theorists who refer to specific aspects of social economy in the same way.

– “In combining these knowledges of a different nature, economists respond *only to practical requirements*, without this modifying the peculiar formal nature of the individual knowledge” (p. 49).

– “There is no exact theory that can by itself give us a universal theoretical understanding of the world of phenomena or of a part of it, not even of a single complex phenomenon in the real world, in its entirety. Such an understanding can be obtained through the *complexity of exact science*, in that each science offers us the understanding of a particular aspect of reality”. “Not one of the exact sciences does in fact contain within itself the universal theoretical understanding of the minimal part of the real world but, as we have already stated, each teaches us to recognise only a particular aspect of this regularity” (p. 56).

– “Whoever tried to reach this result (by widening each individual exact science to universal empiric reality) rather than trying to reach a universal understanding of the concrete phenomena through the *entirety* of these sciences (which is something very different from the *mixture* that Zingali, Griziotti and the others who follow refer to) would go against the most elementary norms of science, to such an extent as to question whether its intervention in the discussion of a difficult problem like this would be justified” (p. 57).

– “Exact theories give us an understanding of some aspects of *all* phenomena and therefore the science cannot even be referred to as unilateral when it entirely fulfils its task”.

I would like to include some of Pareto’s statements, whose scientific spirit does not fall outside the purpose of my treatise on the setting of the financial problem. For example, in the *Manual* we read:

– “Each law or uniformity is true only in certain conditions, which indicate which ones are the phenomena we want to differentiate from the others” (p. 8).

– “Sciences that are able to rely on observation separate some phenomena from others simply by abstraction; sciences that are also able to rely on experience can materially put into effect such abstraction; but for all sciences abstraction remains the preliminary and essential condition of all research” (p. 13).

– “When we return from the abstract to the concrete it is necessary to put together again those parts that we had pulled away from each other for the purposes of the research. *Science is essentially analysis; practice is essentially synthesis*” (p. 16).

– “*Practice* is not in opposition to theory, but unifies various theories which apply to the specific case being examined, and uses them for a concrete purpose.”

“The economist, for example, who supports a law taking into account only its economic effects is not being too theoretical: on the contrary he is not being theoretical enough because he ignores all the other theories that he should consider together with his own to judge the practical case” (p. 17).

– “Separating (in this way) the parts of a phenomenon, analysing them separately and then bringing them together again, making a synthesis: this is something that can be done, and can only be done, when science is very advanced; at the start all parts are studied together, and analysis and

synthesis are confused with each other. This is one of the reasons why sciences start as art; it is also one of the reasons why sciences, when they develop, separate and divide.”

– “Sorel, in his book *Introduction a l'économie moderne [Introduction to modern economics]*, would like to go back to when there was no distinction between analysis and synthesis, and his attempt is explained with the argument that social sciences are not yet very advanced, but it is like going from the river to the source, as opposed as going with the flow. Moreover, in this way we theorise implicitly. In fact Sorel clearly does not aim to describe only the past: he also wants to understand the future; as we have already said, however, the future cannot be linked to the past without explicitly and implicitly admitting some uniformity; and these uniformities cannot be gleaned in ways other than through scientific analysis” (p. 18).

The two aspects have been the object of separate treatises, some for centuries (financial economics) and some for decades (financial law). They have to be studied separately by experts who, in addition to specific competence and cultural training, have theoretical sensitivity and responsibility for the knowledge of the two distinct branches of science that, even in the context of the same phenomenon, respond in very different ways to theoretical questions and therefore take on very different characteristics.

C) It is necessary to go beyond the strictly scientific field created by the contribution of authors who have been real formulators of theories, into the field of economics and law, to find points of view from which the two types of investigation can be configured as a *single* requirement for knowledge.

a) We are not doing this when Benedetto Croce, in a philosophical setting (*Filosofia della pratica [Philosophy of practice]*) additionally identifies legal and economic activities.

For a start, the “legal” concept is different from that which we need to discuss in the scientific approach to the content and the methodology of legislation.

Indeed “law” is, in Croce’s view, a determined action whose content is made up by a series, or classes, of actions. Legislative activity is not necessarily moral and, to define it in its total extent, it must be referred to as generically practical or simply economic.

“By moving from the legislative activity to that of who implements or applies the law (activity which Croce defines, by convention, *juridical*), and asking whether juridical activity is moral or separate from morality and, if separate, what its distinctive characteristic is, the answer – so Croce reports – becomes simple for us: so simple that it is nearly unnecessary to express it in words.”

“It is not only that the activity that implements the law cannot be intrinsically different from the economic and ethical legislative activity, but that it must also obey exclusively *practical* principles; and juridical activity cannot therefore be merely economic, and it can be moral. Affordability is the general form that surrounds the other, the legal activity form, which is generally *practical*, that is, *economic*, and as such it is different and bound with the moral form.”

The *identification* is expressed by Croce in the following terms: “Juridical activity does not only come under the wider heading of economic activity, but it is absolutely identical to it: juridical activity and economic activity are synonyms. Legislative activity, as it comes under the heading of economics, is however differentiated from it as volition of the abstract, an indeterminate volition; juridical activity, however, concrete and determined like the other, is not differentiated from the other by any secondary characteristic” (pp. 349–350).

I wanted to recall this philosophical vision that from a particular point of view may possibly concern the *nature* of the *content* or of the *object* (activity). In the field of our interest, this is the only aspect taken into consideration from separate disciplines for the purpose of scientific specialisation.

We cannot, however, deduce that a *single science* must analyse one *activity* that is identified as being both economic and juridical (in the strict sense of the word), to be philosophically *practical*. In fact, the identification of the two *activities* inhabits a philosophical construct that aims to split its spirit (differentiated into theoretical and practical) into two sub-categories or forms. We can call the first utilitarian or economic, and the second moral or ethic. Croce’s vision therefore is not in contrast with the clarified, justified and supported scientific specialisation of these lessons.

b) *Apparently* closer to the concept of synthesis that we have criticised and do not follow in these lessons is the vision expressed in a setting which we may still call philosophical but that bears in mind the methodological position, the scientific vision of those who arrange the respective disciplines, and not the objective of economics and law.

I refer to *Pensieri varii su economia e diritto* [*Various thoughts on economics and law*], by Giuseppe Capograssi⁵⁶, which considers them as two worlds in the practical activity of the subject. Capograssi pays homage to Croce's concept that reduces philosophy of law to philosophy of economics. He does however insist that it is necessary to justify the difference between these two worlds or at least the appearance of duality they present in common experience and in common awareness.

What is relevant here is the statement that "from any speculative point of view the problem of this duality of aspects remains".

So Capograssi, to explain this duality of aspects, suggests seeing how these two worlds present themselves; he considers which interests and hidden objectives the activity hides behind to construct these two autonomous worlds; and he determines the relationship between these two forms of experience.

Again with Capograssi, we have a case of identification in place of a *definition*. "The law, which is subject to economics and postures as economics dictates, is a pure and simple means. That is, as the means is nothing other than the same action as it moves and proceeds towards an end, law is the same thing as economics."

"So for many economists the system of law is no other than the formulation in general norms of what are the fundamental conditions of economic life; economic conditions expressed in formulae: the result of a long selective process that has followed the system of tastes and the system of consequences that these tastes have operated in the sense of profit of kind. The law is therefore an asset of economic conditions: economics."

After this reduction, by definition, *ad unum*, Capograssi states that undeniably: a) the law presents itself ahead of economics with a certain autonomy, its own criteria, a life of its own, as a real and independent development, to which economics itself has had to adapt and that has in fact dominated and continues to dominate the very economic process, steering it in different directions from those that economic logic would require; b) on initial observation the law may present as a means of economics but an autonomous means, a means that is barely recalled, that operates on its own, carries out and displays a powerful life of its own, that not only helps to support but also upsets and throws into disorder what would be the purely economic life of the experience.

"In essence, what does the law do if not compel subjects to maintain determinate positions, to respect the fixed *status*, economic and non-economic situations which would otherwise be fluid, crystallise positions of interest, of benefits, of uses of things that economic logic would always tend to dissolve, possibly resolve the perpetual research of utility and hedonistic extremes, in the perpetual conflict between results and costs? What truly characterises the appearance of the law is the appearance of the contract and the law: that is, the appearance of sphere centres, of points removed from the fluidity and fluctuation of economic currents."

After this and other similar arguments, Capograssi recognises that these two forms of experience cannot be confused: each one has its own individuality, each one separate. "The problem of relationships between one and the other is borne precisely because each one is separate: each one is in connection with the other, in that both participate in forming a single concrete action, the single story of action, the only way for the subject."

In conclusion, after having considered the object of the science of finance in the strict sense and of financial law, as at the start of this paragraph, we understand how the *dualism* is correlated to the relative *objective content* of the distinct analytical examinations of financial economics and financial and fiscal law, principally. This is also the case when the law and economics are identified

⁵⁶ Scritti in onore di Santi Romano [Writings in honour of Santi Romano], vol. I.

by the experts of philosophy or of philosophy of law here quoted, in classifying the content of the *action of operating subjects* according to particular logic categories.

VI.

RELATIONSHIP BETWEEN LAW AND ACTUAL PHENOMENON (POSITIVE SYSTEM)

A point of view which encompasses the overall concept of the same phenomenon on the part of financial economics and financial law respectively concerns: a) the different priority which is given to *hypothesis* in the two sciences, and: b) the different fields in which they operate and the degree of abstraction they confer to the two types of scientific research.

In the field of financial economics, as pure theory, there is no limit to the scientific choice of hypotheses, as they can reflect conditions which do not necessarily have a link with the actual phenomenon in the past, the present and the possible future as it is subjectively perceived.

With regard to this, we reach the extreme concept which indicates that what matters in our pure science, whose only aim is abstract knowledge, is the coherence of logical developments deduced from given premises, given postulates and very precise hypotheses. The applicability of such thinking to an actual phenomenon and its link with reality may not even exist, or may exist only indirectly.

Given that the task or objective of science is that to explain and make sense of facts and phenomena, there are some people who, with regard to the choice of hypotheses, suggest essentially (though accepting as legitimate the logic of these hypothetical approaches and the subsequent logical deductions deriving from them) that these have their own ability to reflect the real world of yesterday, today and the one which is most likely probable tomorrow, even though this might only be in a specific way. This is therefore an issue about keeping science in the field of pure knowledge and research of real logic, while not forgetting history as we know it or as it might be expected to develop. The problem with productiveness of hypotheses and premises or of the links and conditions that limit thinking, is that in any case these remain pure theory.

In the setting of pure economic theory (in this case, financial theory), a further differentiation of these hypotheses is that they transcend reality to an extreme and lose sight of the application of facts in the legal system, as very little weight is given to these in juridical science generally and in the science of financial law.

I refer to two experts in general theory of law whose work has greatly contributed to the progress of public law, in the context of which financial law is a specialisation. I quote those passages in which these ideas are introduced, hoping that I am not misinterpreting their thinking.

A) In a piece by Kelsen we find⁵⁷ a certain analogy, a first consideration of his hypotheses, with the concept of pure economics theory (financial in this case) that uses abstract hypotheses for coherent logical constructions, without concern for their direct application, as this is the *conception of pure natural law*.

In fact it is only according to the hypothesis, which he considers to be utopist, of “perfect” mankind (in the sense that just and legal behaviour is a concept which is equally and immediately plain to all men; and that all men have the goodwill to behave in acceptance of this norm) that there is no need for a compulsory *positive system*.

But the objection, or rather the “admission that men are not at all or at least not sufficiently capable of such behaviour, and that they lack this quality of justice, proves nothing other than an objective system is missing – a system in which the principle of justice can be expressed. This objection – Kelsen continues – hits the nail on the head from an *empirical* point of view (such as the one taken from positivism and which must be considered in particular when faced with the problem of *realisation* of a normative order); this objection would not however fit the immanent point of view of

⁵⁷ *Concetto del diritto naturale [Concept of natural law]*, in vol. *Lineamenti di una teoria generale dello Stato e altri scritti [Outlines of a general theory of the State and other works]*, An. rom. ed. 1934 (?).

pure natural law (as it could in no way be seen as human work), where it is irrelevant whether it is adopted or otherwise in the actions and understanding of men; it would also be inappropriate from the point of view of a doctrine of natural law, which generally ignores the issue of application, that is the realisation of the natural law itself”.

(This concept (which the author stubbornly refutes, being based on the hypothesis – not a productive one and even a logically inadmissible one in juridical theory – of human *perfection* that the same Kelsen considers to be “clearly in contrast with all experience”) could come close to that of a pure economy founded also on currently unproven and yet common and logically legitimate hypotheses in economic theory. No one defines as illegitimate in the field of economic logic the hypothesis of the “perfect” hedonist or of the consumer who has the “perfect” knowledge of the market, etc. Economists have largely based the construction of their science on these hypotheses and others, which are the result of abstraction; they are however capable of being thought of as “contrasting” “any experience”).

The same Kelsen, however, hastens to add that he has accepted his own point of view of a “pure” natural law to demonstrate, through immanent criticisms, that natural law must in the end become human work – in contradiction with his own idea: that the inevitable *application* of the actual fact is necessarily a process of *realisation* of the positive system. That is, “the process of realisation of natural law *overtakes the idea* of this law that is only possible, if it were possible at all, in a sphere that *transcends the empirical man*”.

Kelsen believes that when his rules (natural law) must be directly associated to the real events of social life, just like those in positive law, *because these real events must be applied*, “at that point the question arises of whether natural law can claim to exist beyond any positivity, if it is possible for it to exist in itself as a set of norms which are different and independent of positive law, that is if natural law as such is actually possible”.

Do keep in mind what the same author said earlier: “It is not possible to represent natural law in the transcendent sphere of the empirical man, other than in its general form of abstract principle of justice, of universal law.”

Up to this point the idea of scientific coherence based on an hypothesis holds. But Kelsen adds: “For it to be applied in the actual event, to the individual fact – *and this is its ultimate purpose*, which corresponds to the immanent meaning of both natural and positive law – the *action* of man is necessary.”

If we discard the hypothesis of human perfection (utopist in the real sense of the word), the construction of a system that must apply natural law and whose realisation requires *positive legislation* becomes inevitable.

Reality must therefore be reflected immediately in the organisation of the State. Kelsen confirms this elsewhere: “A State organisation can be presumed to be valid from a normative point of view only when the real behaviour of the men on whom that system has an impact corresponds to a certain degree to its content.” And he concludes: “What is the point of considering valid an organisation for which there is no *correspondence* in real life?”

This concept, by one of the most respected theorists of public law of the last decades, allows us a reference term to evaluate which legitimate field of objectification logically presents the abstract hypothesis in the construction of juridical and economic science respectively. I will make reference to the latter from this point of view later.

B) When we consider briefly another theorist of general law and tutor of public law, Santi Romano, we find the realistic content of the law in a more immediate and necessary way. I will place the following significant observations from his most significant work⁵⁸ in a particular logical order:

a) “The concept of law must be connected to the concept of society” as “entity that represents, formally as well as objectively, a *real* unit, different from the individuals that constitute it. It must also be an *effectively established* unit.”

b) “The concept of law must furthermore contain the idea of social order.”

⁵⁸ *L'ordinamento giuridico [The law system]*, Sansoni, Florence, 1945, Chap. I

c) “Social order, which is put in place by the law, is not what is obtained from the norms, whichever way they originate, that regulate social relationships; it does not exclude such norms: if anything it uses them and they are contained within its sphere, but at the same time it goes beyond them and exceeds them. This means that the law, before it becomes the norm, before it concerns a simple relationship or a series of social interactions, is the *organisation, structure, position* of the same society in which it *takes place* and that it represents a unit, as a self-contained entity.”

d) “If this is the case, the concept which is necessary and sufficient to represent precisely the concept of law, as a legal system considered as an overall unit, is the concept of institution. Every legal system is an institution and vice versa every institution is a legal system.”

e) “The institution must have a *real and objective existence* and, no matter how intangible, its identification must be formal and visible. The institution is a legal system, a unit more or less complete in itself, of objective law.”

The quotations of these masters, whose contribution to the general theory of law is outstanding, are sufficient. Among the great experts of public law this stands out as a category which is necessarily historic in its approach. The immediacy of the relationship between the real phenomenon and theoretical or scientific construction is much less important in the concept of pure financial economics where it does not exist at all nor is it considered directly necessary.

C) The contrast and, in any case, the clear differentiation between the content of financial economics and that of financial law (from the point of view of the different positions of abstraction and hypothesis, to which an actual reality does not necessarily correspond) are expressed in a clear and definite way by Giannini. First of all he clarifies that economic sciences investigate the economic reflections of financial activity. He then elaborates a *correlation* between the various ways (in which financial activity can be expressed) and private economies, while financial law focuses on the institutes and juridical relationships derived from a set of regulatory norms of financial activity. Finally he states that economic sciences “have *universal* value as they derive necessary consequences, which cannot be identical in every place and every time, from given *hypothetical* premises while financial law can only be conceived in relation to a given legal system”.

With a perfect vision of the scientific division of work between the experts of the two disciplines that still have the same phenomenon as their objective, Giannini admits that the real approach of our State and others, as expressed in financial legislation, for economists only represents *historical experiences*, which can supply factual information for the construction of their theories and to test their results.

D) M. Udina⁵⁹ takes a position against the mix of economic and juridical criteria in theoretical construction, by admitting that it would be opportune for financial law and the science of finance to be “known” by experts of the two disciplines in their role, essentially, of tutors. He however considers the same as “different organisations of knowledge” that “can be integrated but never fused into each other, even if the object of their knowledge is the same”. He further conclusively states: “Keeping track of the multiple relationships which connect the various sciences is a matter of wise policy and it can occasionally be useful for the interpreter to keep this in mind; it cannot however be an essential task for the jurist to evaluate together and at the same time the juridical, political, economical and technical aspects of the financial phenomenon.

F) An expert of public law, interested in the subject that uses public law as financial law does, has conceived a perfectly rational view of this. In fact G. Ingrosso stated, differentiating between the two disciplines, that financial law as a subject of study is the discipline that “studies the juridical organisation of the finances of the State and lesser public law entities and the legal relationship they have created in carrying out their financial activity”⁶⁰.

For Ingrosso “the science of finance studies the nature, the content and the limits of financial activity; more particularly it researches the *general and necessary causes* of financial activity (public needs and public services), the norms and appropriation of contributions that private economies pass

⁵⁹ UDINA M., *Diritto internazionale tributario [International tax law]*, Padua, Cedam, 1949.

⁶⁰ INGROSSO G., *Istituzioni di diritto finanziario [Financial law institutions]*, Naples, Jovene, 1935, vol. I.

to the State, their effects on private economies in the context of collective economies; essentially it investigates the *natural laws* and therefore the *general laws* of financial activity”.

According to the same author, “On the other hand, financial law must *disregard* these, always within the limits of what is rationally possible in terms of separating the elements of a single phenomenon from each other”.

It studies the financial phenomenon as a *real* manifestation of the activity of the State and lesser public bodies.

This allows us to understand how, in the mind of the author, in the *abstract* field or the general field imagined and opposed to the *real* one, the financial economics expert carries out a theoretical investigation that, in Ingrosso’s words, is the main objective of the science of finance.

“Financial law presumes the knowledge, on economic and social bases, of institutes whose juridical principles he investigates and of a positive system he illustrates.”

“In the research of the *natural* causes that these institutes generate, the science of finance in turn *benefits* from the knowledge of their *reality* in positive legislation as those institutes are the expression of practical activity by the social being.”

In my view, “benefiting” from reality is neither describing it in detail nor accepting it in its entirety, but a process of observation to derive from reality the “types” of facts and phenomena that influence an hypothetical view: i.e. it gives direction to the individual abstractions and gives *indirect* content to theoretical schemes, or their verification.

This can be a way of creating a relationship between the hypotheses and facts to evaluate the degree of unreality of these hypotheses, even though this characteristic (unreality) is compatible with the construction of pure economic theory. If we want to gain a gradual explanation of the concrete or the real, even if through partial views, it is possible to reflect aspects of the real in these hypotheses, case studies that illustrate the financial legislation of the past and present, without spatial limitations.

F) Take for example the case of E. Allorio, who declares that his “tax procedural law” “was born as theory, prompted by a theoretical need”. But in specifying the main objective of the research carried out in the same work, he believes that he must “first of all take a panoramic view of tax procedural law, with regard to the sources from which it is derived, the various fields it encompasses and the texts that regulate it”. We take from this that the necessary and direct link between theory and positive system is offered by the very theoretical and juridical specialisations that are concerned with the financial event or the legislation that is the subject of financial economics. And this (as it is a hypothetical or abstract theory) does not have the same direct and necessary link with individual and real positive systems.

G) Pugliese⁶¹, a follower of Griziotti’s eclectic position, expresses views of the object of financial law that are not completely reconciled with the orthodox views of the authors previously mentioned, who are generally prone to justifying the contraposition (illustrated in these lessons) between object, technology and methodology of the two disciplines.

In a first observation Pugliese referred to financial law as a discipline “that must be studied with appropriate methods that are peculiar to it”, because it forms a system of juridical norms supported by common principles, different from those that regulate other norm systems. But while he considered that the study of *positive* legislation was only a scientifically secondary part of the object of the study of financial law, he went beyond this by saying that the science of finance “must [without any doubt] take into account” the positive legislation which represents the framework of the financial system of every State. Furthermore the science of finance “must *always* keep in mind, in its own elaborations, the juridical nature of the tax measures being considered as well as the juridical profile of the various financial institutions”. This is so because he defined the science of finance as the discipline that studied financial phenomena from an economic, political and juridical point of view. This has scientific meaning only for the portion of it that is economic in nature, as this is the only element that can be considered to be science, while it cannot be said of a political science, established from a political point of view, from which financial phenomena are considered.

⁶¹ PUGLIESE, *Istituzioni di diritto finanziario [Financial law institutions]*, Cedam, 1938, p. 5.

Finally, stating that the science of finance should consider the juridical aspect of the phenomenon means taking away content or duplicating it with that of financial law.

VII.

THE DOMAIN OF HYPOTHETICAL ABSTRACTION IN PUBLIC FINANCE ECONOMICS

Going back to the generalisations on the range of hypotheses in the field of pure financial economics, I will recall and express some scientific concepts.

Many academics have lingered on the issue of methodology and some, such as Cairnes, Mill, Menger, Jevons, Keynes, our own Berardi and others have even dedicated specific works, or essays (Masci) on this. “Those writers who have more effectively contributed to the progress of economic science” did not make any “confessions” – Cairnes’ words. Our most illustrious thinker and original creator of rigorously resolved problems, Pantaleoni, after describing “methodological controversy” as fruitless, stated: “the most persuasive method to resolve similar disputes is to apply the methods, not discuss them. In essence it is a matter of trying to fabricate a model that approximates reality more closely than the others, and more effective as a heuristic tool for facts and connections otherwise perceived”.

The most significant re-evaluation however is that of Menger⁶² when he declares: “the most significant results from a scientific point of view are those obtained by those who are not interested in methodological research, while those who have given this issue priority have not achieved anything significant from the scientific research whose logical method they had indicated with admirable clarity. There is a vast difference between the determination of a method and a satisfactory scientific construction, a difference that only the brilliance of the experts in this science can breach. Often the brilliance of the scientist has managed, even without sophisticated methods, to build or radically transform a science; the reverse however has never happened: i.e. a methodologist, that is, someone without aptitude for scientific research, has never achieved any significant result. While methodology has an incomparable importance for results of little significance, it becomes of secondary significance when considering those great tasks that only brilliance is able to complete”.

This warning, used in the manner of a preface to the cited essay (190 pages) should also be sufficient caution for those of our own experts in these sciences who become excited at the thought of this sort of elucidation.

The conclusion that Menger (p. 168) reaches with regard to the science of finance is already proof of the debatable productiveness of methodological discussions, to which Pareto⁶³ refers as “a waste of time”. He places the science of finance among the “practical sciences of economics” and he defines it as: “the science of the principles that regulate in the most opportune way, according to circumstances, the greatest single economy of the country, the government, and the other economic subjects who have financial powers”. A certain degree of precepts or cameralism can be observed in this, in contrast with other scientific visions professed by the same Menger elsewhere.

Great theorists – those who make original contributions – do not indulge in staging implicit hypotheses, conditions and restrictions, in pedantic listings which can be acceptable to readers not used to mentally reconstructing the set of assumptions that are logically and necessarily presumed⁶⁴ for given methods of argumentation and their relative conclusions. Those who, like Jevons, recognise that the great contribution made by Newton’s significant work (dedicated to the enunciation of fundamental rules for research, “*regulae philosophantes*”) was very modest from the point of view of

⁶² MENGER, *Nuova collana degli Economisti italiani e stranieri [New Collection of Economists from Italy and abroad]*, vol. IV.

⁶³ Pareto, *Manuale [Manual]*, p. 24.

⁶⁴ Did Enriquez not write (quoted) to Jevons that “in the practice of reasoning, the hypothesis is often implied”? The conditions under which a law or uniformity is real are both partially implicit and explicit. Among the former we need to include those that can easily and without the minimal ambiguity be understood by all, Pareto also advises in his *Manual*, p. 8.

methodology codification, are indeed justified in doing so. “Newton achieved much more when he applied the rules of work without expressing them” (as Baldacci, already quoted, reported in his summary of the science).

A) Here we speak of it out of the *necessity* to contrast the type of investigations required by financial economics, which is an *abstract* science, with those that are more appropriate in financial law (which is focused on the study of the *real* that it takes into consideration in a systematic way, *immediately* and often *completely*, as we have seen in a few but significant quotations).

It is an abstract science to the *maximum extent* when we consider it according to concepts such as the following ones, which have found space in the domain of pure economic theory:

“Given specific premises, economic science will consider them without being concerned about their conformity to reality or otherwise; and the inferences which are derived from these premises are valid within the limits set by them.” Academics do not view this declared position, for example by Einaudi⁶⁵, as heterodox. Even an illustrious statistician such as Boldrini⁶⁶ finds “the definition of theoretical economics, also defined as pure, which starts from specific postulates and carries them through, without being too concerned whether they closely adhere to material reality, as being well founded”.

The coherent reasoning seems science to many people (and it is science to me, too). This also seems to have been Boldrini’s view, symptomatic of a statistician normally analysing reality (he also defined the hypothesis as “a rapid and provisional solution for an induction).

According to Einaudi⁶⁷, “if the premises are not clearly declared and if they have not been rigorously formulated, the theories formulated by economists are *true* within the limits of such given premises”.

The same author considers as *abstract* laws those of pure theory, “the ones that tell us what will necessarily happen in reality every time that *all* and *only* the premises expressed by the theorist actually occur. It is not in the least necessary to place premises, problem, thinking and theory in a specific place and political or moral historical time to demonstrate that the theory is true. It is a real *sub specie aeternitatis*: “a truth whose conformity to real events is not necessary in order to demonstrate its validity, because the investigator did not have that purpose in mind”.

This is an abstract vision which is not disassociated from the mathematical one, when it is compared to statements such as the following ones, by Poincaré⁶⁸: 1) Mathematical truths “derive from a limited number of clear propositions, through an impeccable chain of thought”; 2) considering the function of the *hypothesis*, and after realising that this is not only necessary but often legitimate, this author states: “we will see that there are many types of hypotheses, and when these can be verified and confirmed by experience they become fertile truths; some might be useful in concentrating our thoughts, without leading us astray; and yet others, finally, are hypotheses in appearance only and can be reduced to definitions or to misunderstood conventions” (p. 2).

Poincaré considers geometrical axioms and he adds that the choice among all the possible conventions is *guided* by experimental facts, but remains a *free* choice, and it is only limited by the need to avoid all possible contradictions (p. 66)⁶⁹.

⁶⁵ EINAUDI L., *Rivista di storia economica [Economic history review]*, V. I, 1941.

⁶⁶ BOLDRINI, *Statistica: teorie e metodi [Statistics: theory and methodology]*, Giuffrè, 1942.

⁶⁷ I quote Einaudi, who was particularly effective in clarifying methodology in his brilliant work: *Ipotesi astratte ed ipotesi storiche e dei giudizi di valore nelle scienze economiche [Abstract and historical hypotheses and value judgments in economic science]*, Turin, Accademia delle scienze, 1943.

⁶⁸ POINCARÉ, *La Science et l’Hypothèse [Science and hypotheses]*, Paris, Flammarion.

⁶⁹ He also further clarifies, and the precision is interesting in order to understand the economic abstraction in the sense we treat it here, that “experience has an important function in the genesis of geometry; it would however be a mistake to conclude that geometry is an experimental science, even if partially so”. “If it were, it would be approximate and provisional.” “What an ill-chosen approximation this would be!”

“Geometry would be reduced to the study of the movement of solids, but in fact it does not concern itself with natural solids but rather with specific ideal solids, which are absolutely invariable and are but a simplified and distant image.”

“The notion of ideal bodies is drawn entirely from our imagination and our experience is but an opportunity that engages us in making it explicit.”

There is an echo of this vision in Enriques (op. cit. 42), where he says “that the progress of the human intellect, independently from any correspondence of the achieved result with reality, must be the object of any specific research; this research can then find, among all the variable elements, the subjective data which can represent the event, and in this way it can then enlighten the psychological function of our understanding”.

With regard to thinking in its rigorous form, however, and with reference to experts in *Logic*, Enriques specifies: “for intense thought of this sort (which does not alter the facts of our knowledge but accepts them as true or false) to be completely independent of real empiric proof, and for it to be rigorous, it is important that its laws are recognised as essentially formal and that they are applicable every single time specific conditions of *coherence* of thought are met, regardless of their content” (p. 90).

I believe these combinations are necessary to shed light on the concept of pure economic theory. De Viti De Marco taught us to think of problems of public finance as economic problems to be examined with the same criteria as those used in economic science. The same Einaudi, even though he *compared* abstract and historical hypotheses in his its already quoted methodological work, in the same work recognises that financial science (whose economic model he claims to prefer) has been and will continue to be viewed for a long time as an abstract science and that it must necessarily use models which are more or less close to reality.

After reference to the reputable opinions which dominate this branch of science, and in the context of pure theory, I believe that the differentiation in methodology, or rather in the technique and content between pure economic science and juridical theory, in particular that which affects financial law, is now quite clear. Two different attitudes are necessary when considering the scientific approach to the two disciplines that other quoted tutors and their followers would like to join (mixed treatment) at least in terms of the space given to hypothesis. This is not a negligible issue and it normally precludes the same person following, exercising and scientifically contributing to the two disciplines as they use *different techniques* (as scientific methods are not in contrast in different branches of science). It is especially so if we think of the subjective character of the choice and conception of hypotheses and the relationship between hypothesis, fantasy or imagination of the academic on the one hand, and facts to be explained on the other.

There is no limitation to this fantasy or imagination in pure economic theory, including financial theory. We can consider the number and type, *ad libitum*, of circumstances that actually have an impact as *constant*; we can hypothesise that the marginal value of currency is *constant*; we can imagine a monopoly agent purely motivated by personal gain, with the *perfect* knowledge of the market, making *infinite* efforts to recoup from the buyers of his goods and services the losses from a tax affecting his production, to find the point of maximum profit which is compatible with the burden of taxation; we can presume goods with utility independent from the utility of other goods; we can hypothetically presume the possibility of *typical and representative* subjects of homogeneous groups in the context of utilitarian appreciation in reference to equivalent qualities of available assets; we can imagine a system of perfect free competition and the opposite case of a *pure* collectivism of hypothetical and utopistic “City of the sun”, etc. In any case, this means, according to the meaning and within the limitations highlighted in these pages, dealing with science.

All this is not always logically and technically permissible in the field of the *law*. If we take a modern juridical law philosopher, even one with the most abstract approach imaginable, he will define juridical science by identifying its task as revealing the *essence* of juridical phenomena in historical *human relationships* and *human institutions*. And even though you might think that we are still in the pure, hypothetical abstract world, the same author will tell you that “the essence is nothing

“The object of geometry is the study of a specific group, but the general concept of group pre-exists in our imagination, at least potentially so. It asserts itself not as a form of our perception but as a form of our intellect.”

“It is only necessary to choose, among all the possible groups, the one which will be the *type* to which we will make reference to for natural phenomena.”

“Experience guides us but does not impose a choice; it leads us to recognise not what is the *truer* geometry, but which is the most *useful*.”, pp. 90-91.

but the final process of a series of insights into the *real historical forms* and psychological needs of the law”.

Now listen to another modern expert in general juridical law. He will tell you that “the object of dogmatic juridical sciences is the juridical norms *abstractable* from *really existing* juridical phenomena. However, with reference to *concepts*, science itself must shape them through abstraction, starting however not from concepts already existing in the law, but directly from the observation of *real manifestations* of the juridical phenomenon”.

And this comes from someone who appears to have as abstract an approach as imaginable, when he states: “it is not possible to talk about juridical methodology”. Methodology is not specific to this or that science, but the general route followed by our intellect for the purposes of gaining “knowledge”! He will talk about juridical *technique* that, only by convention, is referred to as methodology, in the case of the law.

B) Pantaleoni, one of the greatest theorists in pure economics, wants to delimit the domain of the hypothesis by asking, in his “Pure economy”, if the hypothesis of psychological hedonism, from which we derive every economic truth, coincides with or diverges from the motivations which effectively influence human actions and if so, to what extent.

By doing so Pantaleoni does not oppose the concepts of pure science that are offered for consideration in these pages. It is not a matter of judging the truth of the economic theories that we derive from this scientific concern; its consequences would be *hypothetical truths*, even when we do *not* bother to verify the hypothesis, because they are rigorously deduced.

Pantaleoni defines *true* science in these terms: “if it were demonstrated that the force, whose effect economics studies, did not exist, economics would be an *idle* science even if a true one, as it would not be possible to base an art on it, i.e. a doctrine of precepts. It is *pointless* in pure economics to study the problems of historical economy, that is, of the past. He uses the case of slavery, which is practically irrelevant when compared to current problems. “There is a lot to be studied in an economy that is no longer based on slavery. Persisting in considering it would be similar to a medicine course that mostly teaches about elephantiasis instead of focusing on far more common diseases.”

This is a sort of self-limitation by Pantaleoni, which could justify Bernini’s reaction, for example against *homo oeconomicus* or the perfect hedonist, who meticulously weighs the pros and cons in his affairs, and who is sensitive to an infinite range of variations in pleasure and pain, etc. It is a reaction against those who want to overlook “a proven law” to replace it with the result of a mental abstraction that is “always the same as itself”; this is an approach that Benini describes as “making logic the pastime of grand thought lords”. The important issue however, in my view, is that we are talking about logic, even without *actual* reference to the real.

Einaudi takes a position against hypotheses “for the purpose of a reasoning exercise” or as “mere parts of solitary fantasy for economists searching for academic exercises”, stating that the “ifs” in the premises of economic thoughts are not solitary or arbitrary creations but are drawn from real life: “they are greatly simplified abstractions of reality”.

These observations, and in particular the one relating to Pareto’s views, *appear* to bridge the gap between the position of the economist and that of the jurist whose constructions, as we have seen, *directly and completely* reflect real institutions. The difference, however, remains because the same experts who have put forward the criterion of hypotheses drawn from simplifications of aspects of reality, both for those hypotheses that are *not* at all verifiable and for the consequences they derive from them, are detached from reality, unlike jurists.

It would be easy to prove this using texts from the same authors quoted in this paragraph, with so-called limit cases that revolve around unreality or that draw only on marginal and distant aspects of reality.

We will however follow an author, Pareto, who has qualified uniformity in economics as *logico-experimental* aspects.

The concept of “experimentation” needs to be clarified but first it is necessary to explain that, unlike Pantaleoni who considered coherent and rigorous logical construction “true” but unreal, Pareto considers a theory to be *true* only “when theory and experience are in agreement with each other”:

“there are not, there cannot be, other criteria of truth for a theory” (*Manuale [Manual]*, p. 39, 1909 edition).

Words do not matter because both Pantaleoni and Pareto agree with what the latter states in this expression, which goes beyond the “obsession with immediate applications, which are the great enemy of any type of theory”: “it is therefore beneficial, when constructing a new science, to choose principles carefully so that it is possible to approach reality as much as possible, even if we are aware that a theory will never be able to reproduce it in every detail”.

It is however necessary to keep in mind that Pareto uses terms such as experiment and observation, in the field of social sciences and economics in particular, knowing that it is possible to experiment only in positive sciences (physics, chemistry, biology, etc.), and that in the social field it is only possible to rely on observation.

Another approach is the one which is normally called *hypothetical experiment*, a term Ricci⁷⁰ in particular insisted on, and which others call the *ideal* experiment, in place of those that cannot historically be carried out. By putting in place specific conditions and by making specific hypotheses, which become more and more complicated to approximate the conciseness of reality, their relative effects can be deduced so arriving at an abstract model of what might happen if the idealised hypotheses, conditions and circumstances occurred.

From the point of view of the observation of *facts* and the verification of hypotheses and theories, the differences between the logical positions of economists and that of jurists would appear to have been eliminated. The issue of the methodological and technical differentiation between the two theoretical fields might seem to be limited to problems of differences in the *degree* of their respective links with *actual reality*. Going beyond Spencer’s view on the equivalence of questions of *relevant degree* to questions of *species*, when these are present, they could be considered to be of limited importance or negligible for the purposes of scientific specialisation and differentiation.

a) On the other hand there are some concepts that make us understand how this difference is still substantial and how a different field of objectification of the logical force is necessary for hypothesis in economics, even when following the logico-experimental method.

In fact, if we consider that the facts that science “deals in” are not only, as Croce⁷¹ believes, those that have already *happened* (“if the fact does not precede there is no corresponding theory”, they can even be considered facts, for the purposes of testing a theory, those that are in the *future* or are *probable*.

After considering as scientific propositions those that can be verified by experience, Pareto admits that “by moving from a premise that cannot be verified through experience, scientific deductions can be made. These similarly cannot be verified experimentally but are joined to the premise in such a way that if this is a proposition that will be possible to verify *in the future* (the italics here are mine) through experience, then the conclusions drawn will also become experimental”. (*Manuale [Manual]*, p. 33)⁷².

b) Among the theories we can choose from “we prefer the one that has the fewest deviations from the facts of the past and that best allows us to predict the future”⁷³.

It must be considered that these concepts are not fruitless and purely methodological. Pareto⁷⁴, however, pointed out the extreme limit case for production in 1896 of the socialist State of the “future” (p. 104), whose hypothetical, repeated attempts led to determining the same production coefficients that are hypothesised for the extreme limit case of perfect free competition (if it were practically possible to replace the “social and unified organisation of production in an environment of

⁷⁰ RICCI U., *Studi in onore di Salandra [Studies in honour of Salandra]*, Rome, 1928.

⁷¹ CROCE B., *Filosofia della pratica [Philosophy of practice]*, p. 29.

⁷²It has been said very recently, in this logical order, that laws or economic uniformities are truths of limited validity, given their logical character: Bresciani Turrone says they are “outside time”, and he adds: “in any community and in any historical period, in the context of a set of premises on which a theory has been based, the consequences in it described will happen every single time, assuming that they have been correctly deduced by the premises”. *Corso di economia politica [Course of political economics]*, vol. I, Milan, 1949, Giuffrè.

⁷³ PARETO V., *Trattato di sociologia [Sociology treatise]*, vol. I, pp. 42-46.

⁷⁴PARETO V., *Corso di economia politica [Course of political economics]*, vol. II.

free competition, the author added). He, however, adopted the formula of logico-experimental science, when there was no concordance between hypothesis and conclusions from reality, with the clause “*in the limits of time and experience known to us*”.

c) There are, however, cases, in Pareto's view, of *virtual* movements, which are different from *real* ones, that is, cases where the community can achieve states other than those which are actually achieved (*Sociologia [Sociology]*, op. cit., p. 57). He also describes the hypothesis of investigating “what would society be like if there were no private property” as “study of virtual movements”. In this case I don't believe that any jurists would consider problems in their own theory that, based on actual past or present facts, appear not to take into consideration virtual situations at least on a systematic basis, in particular with regard to the extent of the repercussions mentioned in this proposition by Pareto, in an “experimental” sociological model. At the same time he assigns to economics the task to study “real movements to understand how events develop” and “virtual” ones (“which do not really take place”) to understand the properties of specific economic states (*Manual*, p. 151).

C) If you open any book accessible to educated men (such as the quoted one by De Broglie) you will find statements that justify this combination of links between hypotheses and their verification or deductions which derive from them. In fact, you can read expressions such as the following ones: a) “Simple images (such as those of a corpuscle or a wave, of a well-identified place in space, etc.) are abstractions, simple idealisations. In a great number of cases these idealisations are *approximately* realised in nature, but there are, however, limits to their application in some cases” ...; b) “More or less schematic idealisations of our imagination *may represent* some aspects of things, but they are limited and cannot contain all the richness of reality in their *rigid models*” ...; “It is very possible that, in the light of new experimental facts or of *new theoretical concepts*, we might be induced to consider laws previously only verified as approximate, that is, to admit that, if the precision of our verifications should fade, they *would no longer be verified*”; c) “The move from classic mechanics (based on hypotheses whose validity is guaranteed only by objects in our dimension) to wave mechanics will necessarily take place in the *abstract model of representative space*” (obviously unreal in relation to our senses).

To those who criticise theoretical physics, as we conceive it, in the same way as they criticise *pure* economics, because based on unreal hypotheses (that is because “the probabilistic interpretation of new mechanics is perhaps very interesting and *coherent* but also a bit *arbitrary*”) we can only say that it “appears to be the only one possible” (today). De Broglie continues: “it is possible that abstract models and concepts”, that is “idealisations” appear to be too simplistic products of our thought and “cannot be applied exactly to reality”. To describe the complexity of reality it may therefore be necessary to “use two or more of these idealisations, one after the other”⁷⁵.

My statements regarding the affinity of theoretical concepts in physics and economics as the characteristics which differentiate them from the much better defined validity of the hypothesis in the field of the law, and with regard to their verification and the verification of their respective deductions, appear to be contradicted by a stream of opinions, which are controversial and not widespread, that not only consider the possibility of a quantitative or mathematical theory of juridical science but also want to consider it as a science with great affinity to natural science, in particular the physical ones.

Magni, encouraged by current sociology experts (who believe in a juridical quantitative theory), firstly agrees with Ricconi (*Jus*, Rome, 1939, regarding the possibility of applying the mathematical concept of *derived* or *integral function* to the law) and then he suggests analogies with natural sciences. Finally Magni admits the possibility of conceiving “jurisprudence as a naturalistic

⁷⁵E. Fermi wrote, among other things, about the *provisional nature of hypotheses* in the context of the probability of their verification in the *The Physical Review*: “In recent years many new particles have been discovered and we have assumed these to be *elementary* forms, that is, essentially without structure. The *probability* that all these particles are actually elementary becomes smaller and smaller as their number increases. *It is not at all a certainty* that nuclei, mesons, electrons and neutrons are all elementary particles and it is possible that at least some of the fallacies present in current theories might be due to having ignored the *possibility* that some of them might have a complex structure.”

science”, especially in reference to physics conceived as “a sort of logic of pure energy”. In this way he projects the analogy to the point of considering “energy quantum” in the field of the law, intended as a determined energy, derived from the system (law, sentence, etc.) that determines a juridical effect.

On the basis of these assumptions, he agrees that it is possible to quantify the law and he finds in mathematics the bridge that could firmly join the techniques of jurisprudence to that of natural sciences. He believes that “the aggregates of the law” can be treated as combinations of fundamental quanti of energy or action: “quanti of determinate or intellectual energy of individuals, combined with quanti of sovereign powers (normative, administrative and jurisdictional laws)”, or “only quanti of sovereign power (power of rule)”.

Magni applies variations of quantity with a functional ratio to ability to act as a function of variations in the position of the subject.

He continues: “It would certainly not be easy to develop practical procedures other than after scientific activities by many experts, who might have a mathematical, sociological and juridical preparation adequate to the seriousness of the task”. Magni, with spirit, does not hide the possibility that the suggested hypothesis might be revealed to be “devoid of any scientific or useful basis”, and be so reduced to a simple exercise.

For the purposes of my review of sciences and their respective methods and technologies, at this point I need to observe the following with regard to Magni’s analogical and quantitative position:

a) that this position, if it were fruitful, would require such an extent of specialisation, even among *jurists*, as to make it very difficult to have the same type of preparation in economics experts, in spite of the effort to bring these roles closer by presenting the law as a quantitative science such as economics, which is essentially so.

b) that: 1) he has attempted an *explicative* theory of the juridical *system* (even if not in its entirety); 2) he has made reference to data that refer to positive systems and not to pure logic; 3) he has made reference to a “series of facts relevant to the law” and to “objectively observable” variable qualities, influenced by the normative and regulatory activity of the system; 4) furthermore, he refers to the principle of interdependence between norms and specific cases; 5) he admits that the proof that “a juridical system is not a disjointed system”. Finally, after further debates, he concludes: “in the juridical world we can scientifically try to specify the rules of juridical *experience*, that is, of the movement of juridical entities in a *given system*”.

If we compare the needs of the theoretical economist with the needs of this modern and already debated juridical quantitative theory, we find that the link between the world of hypotheses and the concrete juridical world is more immediate, continuous and necessary than in the field of pure financial economics theory. This is also the case when we refer to “what mostly happens” when we talk of “real effects” in the relationships of causality, that is, to probabilistic aspects of reality.

D) Finally I want to remember an important differentiation in the position of economists and jurists with regard to the same actual subject, which is represented by the financial legislation.

a) Juridical theory pursues no aim other than that of *understanding* the *established* law and the legislative and executive activity, without taking a valuational position. It is a theory that does not attempt to answer the question: how the law, good or bad, just or unjust as it may be, *is actually* established. It is a science that does not represent the doctrine of the *just law*, but a general juridical doctrine entirely aiming at the problem of *how* the law can, generally speaking, be established. It is therefore a doctrine of the possible law, *really* established and that represents therefore a doctrine of the actual law.

“Pure” doctrine of the law is none other than a theory of positive law, and it has no other aspirations. Its aim, in the field of the law, is that of understanding what *exists*, without questioning what *should be*. Therefore, not a “must” but a “be”, a positive reality in being.

It is true that this orthodox vision is mediated by the other various doctrines that deal with the “gaps” in the juridical system and how to bridge them. It is, however, very rare for the interpretational critique of the system and the laws to lead to visions of *de iure condendo*, suggesting how the law *should be* so as to be technically perfect and as to express the real will, for example of the State, without gaps, deficiencies or inconsistencies.

b) On the other hand, the *critique of laws* or their evaluation and the vision of what they “should be” can be defined as a *rule* when reference is made to tax legislative systems by experts in the science of finance.

It is not the critique of who wants to make suggestions to the legislator, by making financial *art*. In this case the *should be* comes under the heading of precepts that go beyond the conception of science for the purposes of understanding. “Everything that sounds like precepts is not scientific”, so declare the masters of economics theory.

Various methodological works and writers, such as Pareto and Einaudi, already quoted, insist on the shifting of the scientific language of precepts by economists. In fact to state, for example, that a real tax that draws revenue from a single source *should* not be progressive is equivalent to setting a *hypothetical* thought such as the following: “if the legislator thinks on the basis of the principle of equality of sacrifice (for example, working on the *hypothesis* that it decreases, with a *given* variation rate, as the total income available to physical people increases), a progressive rate is coherently conceivable only on the *basis* that the income relates to a physical person and does not relate to the income of a *single* source”. In the light of this *principle*, adequately demonstrated, the expert criticises and condemns the real tax on the income from a single source, if collected for the customary purpose of raising revenue (tax) for the State, if it is done with a progressive rate.

Given this, it is to be noted that the pure economist (one who considers positive financial law systematically or as an example, that is, with the purpose of illustrating the fruitfulness of *hypotheses* as their verification in the face of phenomena that the theory tends to explain) *tends* normally to take a critical position with regard to the legislator. The “should be” is proposed, in the spirit of hypothetical science, in theoretical reasoning, from the specific economic point of view⁷⁶ when we consider the divergence or convergence of systems and positive institutions to (and from) types of general models or individual taxes clarified on the basis of abstract characteristics of *hypothetical* rational concepts.

For example, this criticism is aimed at *positive* systems:

a) with regard to characteristics: for example, the object of direct taxation on assets or incomes, for the correspondence or otherwise of quantities enshrined in positive law to those identified with theoretic concepts of net capital and produced, earned, disposable, distributed income, etc.;

b) with regard to cases concerning the choice of means according to the purpose, when making formal reference to wealth production events, to hit indirectly consumer events (by shifting of duties or by *hypothetical* economic processes diverging from the possible legislative faculty of compensation of consumers by producers);

c) with regard to the adoption of different rates for the same homogeneous category of taxable assets (income, for example, of pure workers);

d) with regard to the differentiations of rates according to relationships not corresponding to different theoretical investment risk;

e) with regard to methods of distribution of taxes, apparently, or according to the legislative command, proportional to income of different classes of sources (for example, tax on expenditure or on the location value of dwellings) and essentially regressive, that is, with a higher impact on lower incomes. From this comes the apparent “precept” that suggests a principle of objective economic equality, with progressive rates in the *hypothesised* case. And so on, for the multiple points of view from which the critique can be carried out, in the light of scientific logic, to the extreme-case point of view (economic) that the expert in public finance economics takes into consideration in his hypotheses.

The purely economic point of view is without doubt a partial one, but it is coherent and rigorously correlated to scientific specialisation. By putting forward critiques or suggestions that appear to be advice and precepts, no expert intends to dominate the actual phenomenon from his own restricted (economic) point of view, but rather intends to suggest, while delving into a critique of laws, elements of judgment that can *indirectly* and partially influence the development of positive

⁷⁶ And not from *all* points of view from which positive institutes are examined in reality, as Griziotti, Zingali and others think, given their so-called synthetic conception of the science of finance.

systems. All this is clearly *in the limits* within which the economic element is historically combined with other factors determining positive laws, and in which the *purpose* of the critique, carried out in the light of hypothetical and abstract science, is not in contradiction with facts, as they are outside of the hypothesis⁷⁷.

My position is the one that is dominant in English-speaking countries, where this discipline is known as “public finance”.

VIII.

AUTONOMY OF THE SCIENCE OF PUBLIC FINANCE FROM POLITICAL ECONOMICS

In the light of this process of scientific differentiation and specialisation, it is possible to identify the reason for considering the science of finance as an autonomous discipline. In other words, it is a body of knowledge and uniformity focused on a *group of hypotheses* relating to the modification of the economic equilibrium. This *group of hypotheses* relates either to methods, and their relative effects, of distributing the cost of public services, of distributing expenses, of splitting the overall taxation burden among individuals, groups and the community, or to methods used to deploy capital assets through public debt or extraordinary taxes, etc.

Einaudi was of this opinion. He also stated (*“Rivista di storia economica”* [Review of economic history], March 1942) that trying to demonstrate which “discussions” belong to “one or other discipline” is “a problem without meaning”. So he argued, after making the premise that the study of the “effects and shifting” of taxation has a completely “intrinsic link with the so-called science of finance”. He also believed that it is “a mere accident that such a study has been appropriated by finance experts”⁷⁸. He declared this in reviewing Fasiani who (after paying homage to the *continuity* of the problems dealt with by the science of finance, economics and economic policy, as all other academics do) admits the arbitrariness of the limitations in the field of investigations to ensure that some logical order is maintained.

We could agree with Einaudi with regard to his review of Fasiani’s *Principii* [Principles] if he had meant that the real scientific content of the science of finance is constituted by problems considered according to the methodology and the logic of economics, and that the specific hypotheses regarding financial activity can be considered also by experts of general economics, without the need to make a clear distinction between the two disciplines which use the same rational and methodological approach.

Einaudi’s position, however, as expressed in the given quotes, is *against scientific specialisation*. This specialisation is, however, necessary for the purposes of teaching.

Courses of civil, commercial, industrial, agriculture and marine law are after all branches of private law. Even so, they are treated differently not only in terms of teaching, but also with regard to specific analysis of systems and institutions by experts who, even though within the context of juridical techniques and methodology, particularly insist in keeping the individual sectors of legislation separate. They do so in order to frame specific branch problems and cases, in the context of private law principles already recognised and to clarify new ones.

⁷⁷ I will also point out the article: E. D'ALBERGO - *Sul metodo nello studio della finanza pubblica* [On the methodology in the study of public finance], in “Riv. Internazionale di Scienze sociali [International Review of Social Sciences]”, 1935.

⁷⁸ Einaudi would have known that in the last few decades some fashionable economists have been dealing with problems of finance without keeping abreast of the specific problems financial literature focuses on. Whatever you might think of the differences and the autonomy of the various disciplines, intended as a group of specific problems regarding a more or less linked set of hypotheses, it is, however, essential to be professionally and continuously involved with them. Otherwise, as we have seen with the previously mentioned economists, we run the risk of selling ice to Eskimos, that is, to generally go over primary elements of models, theories and problems generally that have already been widely accepted for some time. The same could be said, as Einaudi knows, for the various research trends and in-depth analyses in our own discipline.

As I demonstrate in this paragraph, there are problems relating to the State or lesser public bodies that may not be of interest to the constructor of general models of economic equilibrium or of theory of prices. There is legislation in various countries that regulates this activity. Such legislation, even in the context of specific typification, can provide the expert in financial economics with specific hypotheses and in-depth analyses that would not be of interest to the general theory experts, as they would themselves recognise. I will later quote Pareto, who was a master in the field of rigorous methodology. As we will see, in fact, the student who has attended two courses of political economics will be interested in hypotheses that, systematically viewed from a given point of view (in this case the economic one), may provide a set of coordinated knowledge concepts with regard to the activity of subjects (*public* bodies) that influence economic quantities.

Linking the content of the science of finance to a single criterion, the economic one for example, can lead to the conclusion that some types of research do not belong to this scientific branch: that is, types of research, as Einaudi tried to demonstrate, in which the expert may express “value judgements” that may perhaps be appropriate to political science or sociology or history. It is no negligible “result” to fix the limits of disciplines if we avoid, both in their teaching and in theoretical research, contaminations such as Einaudi’s presumption, which would take homogeneity away from analyses that need to be contained in the rational field, with objective sets of quantitative relationships.

Given this premise, in the spirit of specialisation and for all observable cases that can be possibly suggested by the reader, I am trying to identify the reasons for the establishment of a separate body of knowledge, in the systems of the science of finance, as different from political economics (even though not so clearly or rigidly, as I will admit in the following paragraph) for the obvious purpose of communality of methodology and field of research (economic).

a) Already at the time of Adam Smith, a general treatise by an anonymous French author moved from a set of precepts still closely tied to reality (the science of the chamber of commerce, or rather financial art) to the vision of a first approximation of theoretical uniformity that may feature in today’s treatises on the science of finance. It is, however, necessary to recognise that at that time for classic academics the study of the financial phenomenon was *confused* with the wider set of interesting facts pertaining to political economics, in their own definitions.

The action of the government (expenditure and revenue) revolved around the issues relating to the use of wealth, which were analysed in this science as it was then viewed. With Ricardo, this view shifted to analysis of production issues and in particular the *distribution* of wealth, which is affected by tax collections that have an impact on costs, salaries, incomes, profits, production volumes, building rents, etc. The different treatment, which corresponds to the title of Ricardo’s work (*Principii dell’economia politica e delle imposte [Principles of political economics and taxation]*), is not enough to indicate that there is already a scientific specialisation, even though it is possible to detect a first indication of research relating to the economic effects of numerous varieties of taxation.

b) In more recent times the study of public finance has been more systematically differentiated, not so much in terms of methodology or techniques of theoretical research but in terms of the organic and more frequent consideration of specific hypotheses and typical events. I refer, on the one hand, to a time when economics was influenced by the *hedonistic theory* (studies on *marginal utility*), which has been systematically applied in the field of public finance even though not always in a satisfactory way. This was especially so when there was a trend towards explaining the overall financial phenomenon using the subjective element (utility), in the attempt (not yet completely abandoned and, in part, still fruitful) of conferring meaning to mass phenomena by focusing on the utilitarian variable examined in the study of the rational behaviour of individuals. We will refer to this type of investigation later, both when we consider attempts to explain, on a hedonistic basis, the overall financial phenomenon and also for the applications of the study to the relative methods and uniformities relating to the distribution of the taxation burden (progressive taxation) or some of the effects of taxation (removal of taxation). Finally, we will consider what solutions are preferable for some of the problems (public debt or extraordinary taxation, in the light of the respective “benefit”, which is wiped out in the two cases) that are associated with the so-called “extraordinary finance”, or

the collection of contrasting types of taxation (direct or indirect taxes, respectively, on incomes or consumption), etc.

These are two theoretical approaches to problems that still have the ability to explain a particular set of events (variations in quantities in private balance sheets in relation to public balance sheets and the activities of the respective entities), by insisting on a set of hypotheses that have as object these same sets of events. We cannot however ignore theoretical models based on the so-called principle of the “relative utility”, as defined by Graziani to qualify general models and partial applications of the *hedonistic hypothesis*, although we discuss them and we criticise them for being in part unsuitable to explain these events. The names of Sax, Mazzola, Conigliani, Ricca-Salemo, the same De Viti De Marco, and the contributions of Pantaleoni and Barone, cannot but be remembered in relation to a period when the science of finance, as financial economics, was coming to the attention of worldwide academia, and making ever more logical the creation, in the academic field, of a discipline separate from political economics.

c) It is possible to identify another point of view from which to explain the rise of this specialisation in the field of economic theory, which still has current value in terms of scientific progress, with regard to the *theory of prices*.

This is not only because of the influence that, as I will say later, the set of “duties” put in place by public bodies in carrying out their activities has on balancing price setting in the widest range of hypotheses of market conditions.

It is also because the economies of individuals who, in the context of reimbursement to public bodies for the cost of their activities, have to face a range of corresponding methods that, even though public services prices are considered, they do not give rise to the sort of uniformities that have been elaborated by pure economics for prices relating to a private exchange.

This, without necessarily agreeing with De Viti De Marco, who put forward the following cases: 1) of a *monopolistic* public organisation (for example a State one), with an analogy that compares it with a company providing public services offering the same services at prices (tributes) exceeding costs; and also 2) of a cooperative organisation that offers services without any class of differential benefit between costs and prices because, hypothetically, costs and prices tend to coincide. It is however the case that in public finance economics it is necessary to explain *prices* in the wider sense. They have, however, different characteristics in terms of their *genesis* from those relating to relationships of private exchanges in a market economy.

It is true that we can we can also admit market prices for public bodies that, using criteria applicable in private exchanges, manage estates, buildings and industrial assets, without the immediate or indirect objective of meeting (public) needs of the overall community. Much more frequent cases, however, are those of the following financial institutions or prices in the wider sense, that must be explained by introducing hypotheses that differ from that of the market economy⁷⁹. They are in fact the following logical categories (which aim to explain corresponding hypothetical or historical cases) enshrined in these institutions or prices of public finance: a) *quasi private prices*; b) *public prices* or *political prices* in the strict sense of the word; c) “taxes”; d) *contributions*; e) *special taxes*; f) *general taxes*. These are categories that differ from those that pure political economics experts have defined with the present market economy in mind, with private producers, stockbrokers, etc., operating on the basis of their own profit, hypothetically, with “free” choice. The differential character of these prices in their wider sense (including the tribute that has been defined as “fixed price”, an apparent conflict of terms) has been systematically considered by experts who have analysed this special logical field in more depth. They have contributed the substantiating of a discipline, such as the science of finance, which has an essentially economic background as the science of finance does, that illustrates the differences in market prices in the various hypotheses considered, from pure or general economics, and respective prices, institutions differently defined, that arise when it is necessary to reintegrate the public body’s cost of public service to divisible utility

⁷⁹ This set of considerations was presented in E. D'ALBERGO *Sul metodo nello studio della finanza pubblica [On methodology in the study of public finance]*, “Rivista Internazionale di scienze sociali” [International Review of social sciences], 1935.

and indivisible utility, distributing it among the beneficiaries of services like members of State community and minor territorial and institutional public law entities.

The characteristics of these “prices” will be considered in the context of identification of instruments of public revenues, in the following chapter.

d) α – Finally, from another point of view, scientific specialisation can be proposed to explain the genesis of the science of finance when we consider, as we do in these pages, this “science” essentially for its fundamental aspects and for all the quantitative problems considered exclusively as theoretical economics, based on hypotheses and typical events gravitating around the activity of public bodies or events of the market economy influenced by financial activity.

It can be said that this vision derives from studies of economic theory seen as *theory of economic equilibrium*.

Please allow me in particular to make reference to Pareto’s vision to expand it, I hope without misconstruing it, for the purposes of this paragraph. We have already seen the “contributions” of this author to the science of finance, even recently, on the occasion of his birth centenary (see the brilliant article by Fasiani in the *Giornale degli Economisti [Economist Journal]*, March–April 1949). Faced with what was, in his time, treated as science of finance, Pareto took the position of sceptical critic, partly because this science was confused with the art of government or of administration, and therefore as a set of precepts. It was also because he perceived many of the theoretical attempts as aiming to grant an apparently logical formulation to real party interests, in their handling of revenues and expenses, or because they were logically insufficient.

In 1932 (I will go back to this text: E. D'ALBERGO, *Intorno al concetto di costo della attività finanziaria [On the concept of the cost of financial activity]*, in *Annali di economia dell'Università Bocconi [Economics annals of the Bocconi University]*, Milan) I illustrated a concise rational approach to the overall financial evaluation, using Pareto’s sociological model for the configuration of the *genesis* of a maximum utility for the community.

What I explain here, however, to identify a logical point of view that may be considered autonomy of public finance economics, in the sense of a degree of further specialisation with respect to economics as pure and general science, can *pivot* on one of Pareto’s visions that I have already recalled, in the 1944 edition of these lessons (pp. 28-29 and 248).

This could prove, in addition to, but in particular unlike, what Fasiani concluded – furthermore coherently, as indicated in the works reviewed by Pareto – a very different origin of the same discipline. Pareto could not however conceive a science of finance as other than a branch of sociology. I believe therefore that the science of finance, as “financial economics” or branch of applied economics, can be identified in Pareto’s vision only as an extension of the reasoning that does not make formal reference to the science of finance: all the more so because the scepticism he felt and that I have demonstrated in the previous paragraphs, due to the “composite” content of the science of finance. The contempt for the scientific pretensions of many of its followers necessarily had to give way in the context of the logical and methodological vision here interpreted to substantiate the content of an essentially scientific nature that can be found in the science of finance as well as in financial economics.

I refer to the essay on *Mathematical economics* (reproduced in vol. IV of the “Nuova Collana di Economisti” [New Economists Series]) in which Pareto, among other things, deals with relationships of quantities that are involved in an economic system whose equilibrium is being established (relationships he defines as *constraints*). A case, for example, is that of the constraint that establishes relationships between the manufacturing or production coefficient and the quantities produced.

“There is a great number of constraints that derive from *fiscal laws*, so-called social laws, measures put in place by trade unions, etc.”

“*Applied* economics must study them all; pure economics draws from this study only the *notion* of the *types* that it needs to analyse.” (The italics are mine).

[Before proceeding further in this distinctive comparison, it is incidentally opportune to note that even Walras, the inventor of general economic equilibrium as an interpretative model of events, drew “abstractions from the functions of the State, the services it provides and its needs”].

In this statement, i.e. in this Paretian contraposition, I believe we can identify a *fundamentum divisionis* that explains our scientific specialisation. The *specific* study of constraints, contrasted with that of the types (that is, if we are correct, of their *category*) can substantiate a science that Pareto found opportune to define as “applied” as the greatest approximation of a real phenomenon for the specification of the study, for example, of fiscal constraints. This is a study conducted hypothetically and it is abstract theory, too.

The process of *specification* of the constraints corresponds also to that of numerical extension of the constraints with the approximation of the real phenomenon. In a way it can be said that the “specification” of constraints (as compared to the typical “category” considered in pure economics) implies the consideration of a *greater number* of constraints (degree of abstraction).

It is typical of real cases (paragraph 25 of Pareto’s essay) to present “a great number of other constraints which need to be considered”. Pareto adds, verbatim: “First of all there are collections by way of taxation” (as we see *generically* identified), “and the expenses of public administration”. “The index functions of these collections and these expenses (if there are any) are clearly of a very different category from that of the index functions of individuals”, Pareto briefly states.

So, when he closes the paragraph by saying that applied economics must *study them all*⁸⁰ this clearly make us question the theoretical approximation to reality (number and types of constraints). Pareto’s vision therefore is not that different from the one of De Viti De Marco I have referred to elsewhere, and which is illustrated in the monograph by the title: *Carattere teorico dell'economia finanziaria [Theoretical character of financial economics]* (Rome, 1888). In De Vito’s vision economics is an abstract science because it conjectures problems *abstracting* them from *other* circumstances that complicate them. Financial economics “tries to get as close as possible to reality, and therefore tries to study a real phenomenon, taking account of *all* factual elements that make it up”. He confirms this in *Principii [Principles]* (1934, p. 7).

With this footnote to the parallel proposition by Pareto, he admits that there is a *trend* to study “all” elements that compose the real phenomenon and which the research is “trying” to get closer to.

From this it is derived that the concept of “real” science of finance (which may correspond to that of “applied” economics of Pareto) is based (as opposed to that of “abstract” or pure economics) *on degrees* of logical abstraction. Financial economics abstracts to a lesser *extent* than theoretical or pure or abstract economics. This is so because it in fact considers “other circumstances” that this latter scientific approach does not.

This interpretation of Pareto’s concept of “applied” economics seems not only arbitrary in *determining the specific field of financial economics*, but it is also based on a methodological differentiation which is generally accepted by others. For example, Gini makes reference to it in reviewing the “positions of scientists with regard to political economics” (*Alle basi della scienza economica, [At the base of economic science]*, op. cit.). He differentiates political economics as “pure science”, like the one which studies human behaviour on the basis of some “*schematic* hypotheses”. “Applied economics then intervenes to take account of the circumstances that make actual reality diverge from such models”. He continues: “Applied economics therefore does not represent only the application to a real case of the general conclusion of pure economics but would also lead to the correction of such conclusions, taking into account those *factors* that pure economics *ignores*. For applied economics to have scientific value it would be useful to understand the *laws* which govern the *actions* of these *factors*”, etc.

If we translate the expressions I have highlighted in this context (in italics) in Pareto’s language, we will find, *mutatis mutandis*, equivalence of differentiating criteria, which also recall the concepts of De Viti De Marco we have already referred to, in their logical approach and also in their formal expression. They also lend logical legitimacy to my *deduction* on the subject of financial economics from the vision of general economic equilibrium.

From this point of view I believe that I have completed the contraposition of concepts of pure and applied economics or of abstract and concrete science, as they are known from classic methodological works and that are presumed to be known to students who have followed introductory

⁸⁰ It is meant as a trend.

courses in political economics, with the *specification* of constraints and the general acceptance of *all* constraints. Pure economics considers the “notion of type” of these, an expression that we can correlate to the *category* of constraints, without forcing Pareto’s vision but following its implicit development.

This interpretation of mine, presented concisely in the lessons published in 1944, appears to be reinforced by the following vision, also mentioned in my lessons when I quote Pareto’s *Manual*, with regard to the sharing of tasks in sciences according to their objective (pp. 28-29 and 248, 1944 edition of my *Course*).

With general regard to economic equilibrium (*Manual*, n. 27, p. 335) he also writes⁸¹: “In practice, individual incomes do not originate, by and large, only from assets ceded for production. The *public debt* of civilised states is enormous; only a minimal part of that debt is used for production and often poorly so. Those individuals who reap the benefit of that debt cannot therefore be considered as people who have ceded economic assets for production. Similar considerations must be made for salaries of civil servants, ever more numerous in modern States, and for expenditure for war, navy, and many other expenses on public works. *We will not be considering at all if and how this expenditure is beneficial to society*, and in some cases essential to it; we only observe that their *utility* is of a *different type* from that which *directly* follows economic production”. (I will discuss this later when considering theories in the context of “external economies”).

(n. 28) “On the other hand, *expenditure* by individuals is not restricted only to the goods they purchase. *Taxation* represents a considerable portion of this expenditure.

By a rough calculation, but one that is perhaps not very far from reality, we calculate that in several European countries around 25 per cent of the income of individuals is spent on taxation. The theory presented here would therefore have value only for a maximum of three quarters of the sums that represent the total revenue of a nation.”

(n. 29) “It is easy to *modify it* so that the *phenomena* we have mentioned can be taken into account. It is therefore sufficient to separate the part of income that originates from economic phenomena from that which is unrelated to them, and do the same for expenditure.”

(n. 30) “Individuals spend the part of income left to them according to their own preferences; and with regard to its distribution to different types of expenditure, the same theory applies with regard to the equilibrium of their preferences. The *part collected by the public authority is spent according to other criteria*, whose investigation is not pertinent to economic science. This therefore means that it will figure among the data of the problem to be solved. The laws of supply and demand will follow from the consideration of these two categories of expenditure. If we only considered one, the divergence with the real phenomenon could be significant. For example, for iron and steel, demand from governments affects a significant part of production.”

(n. 31) “With regard to balancing obstacles, it is necessary to consider that the *expenditure* of enterprises is not equal to the total income of individuals, as before, but it is only a part of it, as the remaining part has other origins (public debt, salaries, etc.). Distribution of the part needed to purchase assets transformed by production is determined by the theory of equilibrium with regard to obstacles. The distribution of the *other part of incomes* [is] determined by criteria that, as in the previous case, elude the investigations of economic science, so there must be *other sciences* to consider the data for these problems.” (I am mentioning the 1909 edition.)

Let’s first concentrate our attention on the references I have made to the essay *Economia matematica* [*Mathematical economics*] which reflects Pareto’s thoughts on the issue of division of work among the various disciplines. Without doubt we have proof of the logical reason that explains the constitution of a specialisation of economic theory with the task, among other things, to study the influence of constraints introduced by “fiscal laws” in the economic equilibrium.

The contraposition of “pure” economics and “applied” economics is necessarily linked, as we have seen, to the difference between the type (genus) of constraints and specific characteristics (species) and the number of the same constraints that the theory studies (but always in the

⁸¹ I will highlight, in italics, the most interesting expressions from this point of view.

hypothetical scientific sense and not in a descriptive sense), in honour of the specialisation that Pareto rightly identifies with his rational visions.

From this point of view it would seem that the *scientific reason of the relative autonomy of the science of finance* as (“applied”) *economics* to the phenomena of *public finance* or having as objective such phenomena has already been *demonstrated*.

In the quotes from the *Manual* it is also possible to identify the distinct and relatively autonomous objective Pareto assigned to the science of finance, even though this is not as formally qualified as the “other sciences” to which he ascribed the task to study: *a)* if and how public expenditure is of benefit or essential to society; *b)* the *indirect* way in which public expenditure is *useful* to production, with usefulness of a type different from that of economic assets entering production; this difference would explain the need for another discipline that would make this subject its own area of investigation; *c)* the laws or uniformities that regard the 25 per cent of the income of individuals absorbed by taxation, and which most unequivocally mark the boundaries of political economics, as Pareto explicitly admits, because his theory would only have value for three quarters of the sums which make up the revenues of a nation; *d)* the criteria governing the expenditure of the part of income collected by public authorities that are not the pertinence of economic science, Pareto adds; *e)* the criteria according to which the other part of the income of individuals, which is not the same as the expenditure of enterprises and that has other origins (among which is public debt), is distributed, a distribution of revenue that follows criteria deriving from “other sciences”.

The subdivision of the task of these sciences provides sufficient material for a complete course of financial science or financial economics.

The careless reader will have thought that perhaps Pareto might have wanted to exclude points *a)* and *e)* as subjects of theoretical study in the field of economics, thinking of sociology or politics when considering the competence of “other sciences”. It is, however, necessary to consider how Pareto used the expression “economic science”. The same *Manual* is proof that he did not discuss it in the exclusive sense of other sciences revolving around the field of economics: that is, to contrast economics with other disciplines as a logical order. He defines the concept of economic science in his *Introduction*, dense with methodological significance, to his *Manuale di economia politica [Manual of political economy]* where he explicitly states: “The present Manual has the purpose to explain, in a small volume, the principles of economic science” (also known as: political economics, the expression used for the title of this work).

It would otherwise be necessary to acknowledge (with suitable quotes)⁸² the exclusion of “applied economics” from the scope of economic science, just when he has also bestowed unto it the task of analysing the relationships or constraints that “derive from fiscal laws”. This contradiction is not suggested by the rigorous academic who, stating this in 1911, did not intend to review or change the content of his *Manual* on this point (1906 and 1909).

Moreover, having excluded from the scope of economic science those expenditure criteria for the revenue collected by public authorities from private individuals’ income, if we did not consider the concept of pure political economics (as opposed to applied economics), it would be necessary to exclude from the field of economic logic which underpins public finance economics an admirable and fundamental essay on financial theory. I am referring to what Maffeo Pantaleoni contributed to the history of financial economic theory, *Contributo al riparto delle spese pubbliche [Contribution to the distribution of public expenditure]*. In this work Pantaleoni, who Pareto thought of as a mentor in the orientation of this science, explained the rational thought that could be found in the rulings of “average intelligence of parliaments”.

Similarly Pareto abandons his search (n. 27 already quoted in chapter VI of the *Manual*) for the answer to whether and how public expenditure (for the salaries of civil servants, the navy, public works, etc.) “is useful to society”, even though he suggests an indirect benefit different from that which directly follows economic production. In another similarly well-received work from 1887 (*Teoria della pressione tributaria [Theory of fiscal influence]*) Pantaleoni (to continue with the strong

⁸² That I have explained here referring to *Mathematical economics* (1911) and the *Manual* (1906). The correlation of these dates is significant, as I explain in the text even though I quote the 1909 edition.

economist figure, considering his relationship with Pareto), as I have noted in the previous edition of these lessons, explained the logic relationship among all forms of taxations considered overall, as Pareto would refer to, the percentage (in his example, 25 per cent) of the income of individuals collected as tax. He also, however, envisaged a reasoned relationship between public revenues, as collected from taxpayers, and “the importance of returns that the same receive from the activity of the State”. In considering this issue of evaluation of the social usefulness of the State function, Pantaleoni would have been surprised to realise that his own would not be viewed as one of those works that focuses on the field of science with degrees of specialisation relating to approximations of reality or to specifications of hypotheses that general economic theory would not analyse for reason of scientific work distribution.

This is even more the case when we recall that in his *Lezioni di economia politica [Lessons in political economics]*, published shortly before Pareto's *Manual* (that is, in 1905–1906), in considering generally the theme of usefulness of public services, Pantaleoni put forward arguments that suggested that the services offered by social organisation should be considered as production “factors”.

Think also of the description of the issue of the effects of taxation given by Pantaleoni in his acclaimed *Teoria della traslazione dei tributi [Theory on the shifting of taxes]* (1882), that is, of the variations in the curves of demand and supply determined by taxation law with collection of a portion of income or revenues, or of any other economic units. It was then an atomistic view referring mainly to individual exchange relationships influenced by the taxation event. Now, in macrodynamic terms – as I explain elsewhere in this “Introduction” – it embraces the handling of significant quantities or quotas of purchasing power in the overall market, and places the science of finance in line with the consideration of the mass phenomena studied by current economic theory.

After considering these logical combinations that aim to illustrate and specify the true thoughts of Pareto on what he might have implicitly seen as the object of a study on the “constraint” represented by fiscal laws or the problems indicated in the quotes from the *Manual* listed above, we must categorically deny that he had intended to take away the task of undertaking quantitative research conducted with the methods of (general) political economics from the science of finance, as rationally intended.

We must absolutely reject such an exclusive interpretation of Pareto because of the demonstrated “contradiction which consents not”, in light of my interpretation of his thoughts with regard to scientific specialisation when he refers, in the context of economic science (and not sociology or politics), to the study of fundamental issues in public finance, explained by him and translated by me in equivalent proposition, under the letters *a)*, *b)*, *c)*, *d)* and *e)* of this paragraph.

It is a real shame for the history of theories that, for example, Fasiani, to mention but one, in illustrating Pareto's contribution to the science of finance, paused at the polemical issue, in the context mainly of sociology, where the great economists expressed judgements, for the most part mainly well deserved, on what was then presented as the science of finance in the writings of most writers. Fasiani was seduced by the allure of the dialectics in which literary denomination of “the science of finance” formally appeared; he did not, however, truly understand the real thought that, in the context of economic theory, must unequivocally be deduced from propositions like the rational ones I have analysed. Based on rigorous methodology statements, this is what Pareto *essentially* considered to be the applied science of finance, in the sense I have clarified in these pages, which I hope will help to explain and justify rationally the autonomy of public finance economics, both from the scientific and the didactic points of view. To avoid easy criticisms, this autonomy needs to be understood in the sense of *further specialisation* in research of economic and theoretic character.

d) β - Going back to Pareto's quoted vision concerning the contraposition between the notion of *types* of constraints and *species* of them, it can be said that the step forward taken by the expert in financial economics in “specifying” can be viewed symbolically, by admitting that participation in State initiatives and expenditure, with the supply of public services, is comparable to “external economies” as indicated by Marshall, as I remember. Indeed, by abstraction or convention, as it arises in respect of the charges incurred for services that a single enterprise might use and which are met as general expenses, it could be said that *indirectly*, as Pareto admits above, public services come under

the expenses of companies or individual enterprises, determining quantitative limits for production and average cost levels.

We have mentioned that the term *factor* might be used to indicate the function of the State with regard to production processes. It might be more plausible to consider it as a “prerequisite” for production, by forming an indirect relationship between public services and volume (cost) of production.

By convention, however, on the basis of Pantaleoni’s recalled concept, the function that the State fulfils with regard to *production processes*, that is, the production of public services, has been defined with the expression “factor of production”. What is interesting to consider, however, over and above the issue of words used, is what follows:

a) that *enterprises* (even if they belong to a complex industry, to whom the State offers or imposes services that are *instrumental* for the success or the profit of the process of economic transformation in the widest sense, with creations of abstract utility or physical production of goods that benefit the market) by hypothesis *take into account*, in *combining the remaining factors*, the existence and instrumentality of the State factor (offer of public services);

b) that in particular a part of such services, hypothetically, might be requested and be proportionate in such combination by “choice” of the entrepreneurs who determine a usable *quantum* and an expenditure that can be met at prices which are known “a priori” (public prices, taxes) and are proportional to the *quantum* of differential use of public services;

c) that essentially, in the context of reimbursement of cost of “indivisible” services, the *pro-rata* sum paid to the State by enterprises by way of taxation corresponds to the general expenses of which at least a *quota* represents the equivalent expenditure or relative factor or the prerequisite required by public services used, for presumption of their instrumentality, in the *production activity* of the same enterprises.

Within the limits of validity of these warnings, we can make reference to the so-called “production equation” in which T is the quantity produced, a function of the factors which contribute to its determination: x , y and z , where x indicates or measures prime materials to be transformed, y represents manual labour and z represents capital services: in the context of the warning given and even understanding that “external economies” influence productive combinations *indirectly*, there is nothing to stop representing the conventional factor s , *for equivalence*, as the quantity of public services in the combination by way of the decision of the individual enterprises, or by *corresponding* interpretation of production needs by initiative and by ruling of the State. This is permissible as long as we hypothesise that the enterprise takes account of it, by regulating the combination of the remaining quantities of factors, in function of the usable quantity of public instrumental services, whether they are requested or imposed.

So it is permissible to write the function:

$$T = F(x, y, z, s, \dots) \text{ [I]}$$

In a first approximation, the impact of the discretionary step of assimilation of this factor, as other “*sui generis*” public services, does not appear to be significant in the production equation. It is a *shifting* of specific and internal terms, in business combinations, of the influence of “external economies”, determined according to Marshall’s example by public services such as: communications, road and rail networks, telegraph, press, safety in the supply of prime materials preventing wars, etc. (*Principii [Principles]*, pp. 346-47, *Biblioteca degli Economisti edition*).

(We will see later the limits of this discretionary step taken by assimilating the financial factor to the economic ones that are involved in the combinations of technique or production, and in what sense it is appropriate to talk about *consequences* of the State factor or the quantity s in the values in the equation indicated earlier [I].

In the meantime I observe that, even without making explicit reference to “external economies”, De Viti De Marco takes into account the “moment” when public assets, “after having been produced, return to influence production, exchange and consumption of private assets and so become part of the general economic equilibrium”. In fact he writes: “the equilibrium of production

and private exchanges is different, depending on whether there is good or poor viability, an effective or otherwise defence of property, protectionism or laissez-faire economics and so on". The relative influence of public assets is naturally economically relevant from this point of view if we make the hypothesis that enterprises "use public services differently", an hypothesis which goes a long way to explain the actual phenomena (*Principii [Principles]*, 1934 edition, p. 22, Biblioteca degli Economist).

This reference of mine to "external" economies as opposed to the internal organisation of enterprises, i.e. due to the organisation of the market (for example, due to intervention of the State) as well as to the concentration of production and the increase of this in a large scale, is therefore not devoid of historical content and is in any case hypothetically considered *normal*. In fact not only does Marshall admit that the typical enterprise he refers to ("representative") should "normally" be able to obtain internal and external economies (p. 347), but he also adds (p. 435) that "often the *internal* economies that every enterprise can obtain with its own organisation are very small compared to *external* economies resulting from the general progress of the industry overall". Among the examples of sources of such economies he again mentions the opening of the railways or other communication means with existing markets, in this new reference to the concept which does not therefore regard marginal or negligible hypotheses.

Before quoting P. Samuelson, representative of North American visions of State expenditure with regard to the explanation of the condition of maximum employment of production factors and national income, I will recall that G. Demaria (*Lo stato sociale moderno [The modern social State]*, Cea, Milan, 1946, p. 73 and following) has considered the State a "production factor". This is because the State "creates an institutional environment which favours collective production", or because "it is thanks to public organisation that benefits and enjoyment of public services can be realised".

"Often we talk at length of State expenditure in the abstract, as if it were simply a subtraction from national production. In effect, the statistical definition of the national product is formulated in such a way that State expenditure on assets and services becomes a way to use and produce economic quantities. It is not always more ideal a way than that of production by the private sector of the economy. It is however a way we cannot do without and which will probably continue to develop and – we hope – improve in the future." This is what Samuelson thought of the State. (*Economics*, N. J., McGraw-Hill, 1948, p. 158).

Bresciani Turrone has recently explicitly identified the public services that contribute to "external economies" as factors leading to a decrease in the cost of overall production of a branch of industry made of several enterprises, with reference to the contribution of the function of the State. "Seeing a national interest associated to this [industry], it will look after and facilitate its development with special measures (new roads, railways, expansion of ports, etc.) whose expense will be supported by the entire nation." *Corso di economia politica [Course of political economics]*, vol. I, Giuffrè, 1949, p. 239). This distribution of the expenditure incurred by the State (in particular, given the examples used, those that lead to an integration of State costs with public prices, taxes and contributions, as well as general and special taxes) can be accepted as a first approximation in Bresciani's provisional vision.

With this, the economist places in the general economic model concepts that had been explained by experts of financial economics such as, for example, Einaudi, when he states: *a)* Thanks to taxation, the State creates the juridical and political environment in which men can work, organise, invent and produce. *b)* Man and State together produce a perpetual flow of new assets, through a complicated mechanism: that flow would decrease if it did not fit with the behaviour of individuals and voluntary and coactive collective behaviour.

Analogous thoughts can be found, other than in the already quoted Pantaleoni, also in De Viti De Marco, Borgatta and others in Italy, with regard to the instrumentality of the State function for private production⁸³.

⁸³ V. ZIGNOLI (*Tecnica della produzione [Techniques in production]*, Hoepli, 1950), who was a technologist and economist at one time, for example, talks of the State "as an economic factor" that has a significant impact on entrepreneurs when he illustrates and lists examples of State interventions, quoting from his experience, and when he lists cases of: State loans with passive interest facilities; unemployment benefit; public works,

The symbol s , which conventionally and provisionally identifies public services that are considered in combinations with private services of work, assets and goods to be transformed in the formula [I] (which expresses the equation of production or of technology) is *generic* in this model. To compare it to the specification that could be made hypothetically by an expert of finance, please see function [II] on p. 42.

It is the task of those who analyse in more depth the effects of the function of public bodies, made possible through public expenditure fed by corresponding (considerations) and by imposed prices (taxation), to study the relationships between instrumental interference of public initiative and efficiency and modifications in particular of production processes.

For example, specific problems of financial economics are:

A) the analysis of relationships between distribution of benefits and the relative measure in which individuals, social groups and economic categories reabsorb the cost of public services;

B) the close examination of the indirect economic effects of expenditure that are translated into immediate income for groups, and the effects of services with (objective) economic utility that are immediate and definable with regard to individuals (consumers) and groups of members of the community (public works, military defence, etc.);

C) the consideration of *services* that do not necessarily translate into State expenditure and, like the monetary (devaluation, revaluation) or customs (protection) functions, determine production combinations and *differential* benefits, which taxation modifies because of principles of equality in the State, or because the State wants to prevent the individuals who benefit from these advantages to maintain them in perpetuity;

D) the analysis of the effects of public expenditure on interest rates, on production costs, on national revenue and its distribution;

E) the analysis of the effects of public expenditure on pre-existing curves of private demand, with subsequent substitution of production which is stimulated by the State for that which, in the absence of the State function, would have been present in the market;

F) the vision of hypotheses of the substitution of public assets and services for direct consumption that present a superior ophelimity to private assets and services, which would have been consumed by the taxpayer in the absence of taxation;

G) the valuation, for the purposes of the explanation of the localisation of enterprises, of the comparable pressure of global current burdens hypothetically and historically present in different national markets;

H) the comparison between objective utility of long-term expenditure for the community and actual costs (current generation) of the same;

J) the modification of risk for enterprises, also in terms of expectation of burdens and benefits of State action (collection and expenditure);

reevaluation of agricultural products; agricultural grants; interest guarantee to mortgage lenders; assistance or protection of consumers and their purchasing power also leading to an increase in the economic possibilities of production". These are new forms partly belonging to external economies. The repercussions of State government control and unlimited powers of the State (which is also viewed in this way because of tax collection, which has an immediate negative impact on the enterprise) are identified in these terms elsewhere. WEINMANN 1900–1950 – *Evolution des problèmes de l'entreprise [Evolution of the problems of the enterprise]*, in *Travail et Méthodes [Work and methodology]*, April 1950, Paris, translated in Note di Economia Aziendale [Notes on Business Economics] and edited by the Association of Limited Companies, September 1950. "At any time there is the risk that an event in which the entrepreneur did not take part, about which he cannot do anything, either when it is about to happen or afterwards, might turn up to disrupt his task or destroy his work". The same author contrasts this negative view of the risk that the State causes, both in terms of revenue and expenditure, by modifying production combinations and management budgets, with a more objective one: in fact "control of the model enterprise and effectiveness of management perform their function with a more delicate intervention, due to the multiple internal and external articulations of the enterprise, which produce an echo and a rebound action that are often unforeseen".

These seem to be modern visions of the ways external economies operate, which have been discussed since the time they started being considered in economic calculations, and today even in a probabilistic way.

K) generally, the study of the effects of the financial event on the specific economic equilibrium (single markets, sectors, groups of enterprises, etc.) and on the general economic equilibrium, in function of the *quantum* and the *species* of expenditure and State services.

All this explains how we must pass from the *generic* identification of the fiscal factor in the production equation to the necessary specification, both if we want to analyse problems in static hypothesis or, in particular, with regard to directing the economy towards the consideration of instrumentality of public finance for the determination of the equilibrium in relation to cyclical fluctuations.

If we were to translate into symbols the vision of economic equilibrium, limited here to the field of the offer in the context of the concept of pure economy, in which the fiscal constraint is indicated by *type* or by *category*, we could in this way suggest the generic influence of the fiscal event. For example, from

$$p_a = C_a p_c + L_a p_l \dots [*]$$

where p_a is the price of the product, C_a to L_a are the contributions of the production services of capital (in Barone's terminology) and of work and p_c , p_l the prices of these, with the generic intervention of the tax constraint, we arrive at [*]

$$p_a \pm \Delta p_a = T + C_a (p_c + \Delta p_c) \pm L_a (p_l + \Delta p_l)$$

where T generically represents tax collection and Δp_a , Δp_c , Δp_l the variations that have intervened, because of taxation, in the price of the product, capital and work respectively.

Similarly the financial factor in the field of production could appear, for example, in the equation that expresses the levelling of marginal productivities (for example P , N , M , Q , ... corresponding to quantities x , y , z , s , factors considered above in [I] and relative prices r , n , m , t , ...).

That means that if it were possible to know *a priori* the price of all public services and there was no financial problem in terms of trying to identify distribution criteria of the cost of indivisible public services, it would be possible to also include the relationship between marginal production of public services (Q) and the price of their *quantum*, which is included in the instrumental combination in *production* in the following equation. On the other hand, this relationship appears absurd next to those relating to other assets and services in the equation that expresses the considered levelling of marginal productivities, i.e. the equality of the relationships between marginal products of the various factors and their price, with a $\frac{I}{p}$ ratio, where p is the price of the product:

$$\frac{I}{p} = \frac{P}{r} = \frac{N}{n} = \frac{M}{m} = \frac{Q}{t} \dots \text{ [II]}$$

The analysis of financial economics, however, even though it is limited for example to the first four relationships (excluding $\frac{Q}{t}$ for what comes before) can logically identify the effect of the instrumentality of public services and the imposed prices that public finance economics deals with, as well as a variation of p :

I) in a variation of r , n , m , in function of increments of taxes that are not proportional to the price of goods or prime materials (x), to work (salaries) (y), interest on invested capitals (z) and which, for *shifting*, have been transferred onto those producers who direct their behaviour according to the logic of levelling of marginal productivities;

II) considering the effect both of public services and, at the same time, of taxation charged to the entrepreneur and which affects production combinations, in the sense of *algebraic sum* of increments of productivity (use of public services) and of the decrease of product (tax collections) charged to the results of the productive combinations.

This modification of productivity, which essentially takes place in the financial event, through variations of numerators and denominators in the ratios that only *formally* fall outside the influence of the traditional equation [I], can be caused by hypothetical taxation as follows, *by specifying the fiscal constraint*, with regard to the tax collection:

a) k , that is, a constant, regardless of the *quantity produced* (as in the hypothetical case of a tax on government concessions: for example, the authorisation to initiate an economic productive process or as taxation of a patent to be used, or for the opening of a shop selling goods, etc.);

b) in other words, of type ku , as a tax on the *individual quantities* produced (a certain k fixed for u : for example, per 100 kilos, 100 litres, etc.);

c) as tax of type tp , that is, of tax t proportional in percentage terms to the price (p) of production. It is the case of the tax on consumption or on sales, in monetary terms, an *ad valorem* percentage.

In the course of these lessons the reader will see how many *theorems* and *problems* arise from the *specification* of the “tax constraint”, depending on whether we hypothesise one or other of the constraints here schematically suggested or if they could have an equivalent influence in quantitative terms or in the respective incidence on quantities $P, N, M, \dots; r, n, m, \dots$ that appear as numerators or denominators in the ratios in [II] (indirect influence of t).

d) γ – if we take the model of *production* as it is considered in pure economics and we focus our attention on one of its equations, from which we can determine the equilibrium position of the *consumer*, we find, for example, that a tax can be hypothesised thus:

1) as a reduction of monetary disposable income;

2) as a reduction in the purchasing power of the given monetary income.

1) Let's say that

$$R_0 = p_1 x_1 + p_2 x_2 + p_3 x_3 + \dots + p_n x_n - \text{ [III]}$$

is the equation through which we express the subject who spends his income (as it determines, with other simultaneous equations, the equilibrium budget of the consumer). Maintaining the condition imposed by this given equivalence [III], the general economics expert determines the values of $x_1, x_2, x_3, \dots, x_n$, that give maximum value to the index function for ophelimity:

$$U = \varphi (x_1, x_2, x_3, \dots, x_n).$$

Let's suppose that the income for the subject in question is reduced by a monetary quantity T (which represents, in the hypothesis I put forward for the purposes of this paragraph, a tax *directly* collected from income R_0), so that $R_1 = R_0 - T$. The pure economics problem is, as a rule, to determine the non *uniform* variations of $x_1, x_2, x_3, \dots, x_n$, in function of the elasticity of the respective curve of marginal utility that satisfies the equality of type [III], when R_0 is replaced by R_1 , in consequence of the here hypothesised tax collection, directly from the income available to the subject.

[We are working with the hypothesis that this reduction in income, measured with T , is not simultaneously *compensated* by effects or benefits *equivalent in monetary terms* (to T) ascribable to public expenditure and public services (this is a problem that financial economics would deal with) or other sources of income for the subject.]

2) It is possible however to have a reduction with an *equivalent* trend (on the overall effect on the budget of the consumer) in the monetary expression, from R_0 to R_1 , in terms of the *decrease* in the *purchasing power* available to the subject if there is demand for $x_1, x_2, x_3, \dots, x_n$.

Such reduction in purchasing power at least generally equivalent to the direct monetary one hypothesised in T can result from a variation of $p_1, p_2, p_3, \dots, p_n$ due to the addition of a tax to them, for example, not quantitatively uniform, of the type ku (as we have seen earlier the symbol of a specific tax equivalent to a specific quantity per each unit of physical measurement: 100 kilos, 100 litres, etc.).

So that:

$$R_0 = (k_1 + p_1) x'_1 + (k_2 + p_2) x'_2 + (k_3 + p_3) x'_3 + \dots + (k_n + p_n) x'_n \text{ [IV]}$$

where the adjustments in expenditure and the *variations in value* of $x_1, x_2, x_3 \dots x_n$, with respect to the values they had in [III], are such as to correspond totally, by hypothesis, to those that are compatible with the modifications in [III], when the *monetary* income available to the subject is reduced from R_0 to $R_0 - T = R_1$.

The logic of these variations of quantities required in function of the variation in prices (still *in currency* R_0) is explained by the theory underlying the denomination of (pure) political economics.

3) The "choice", however, by a State initiative of a type of a tax constraint corresponding, respectively, to T or to ku , that is, a tax *directly* collected from income or collected *indirectly* through an increase in the price of goods proportional to their physical *units*, and in which the income is distributed at the time of consumption, *is not indifferent* for the State and the subject, a hedonist in our hypothesis.

In fact a problem that arises in the field of research, focusing, in the guise of a further approximation in scientific specialisation, on the field of public finance economics (or the more rigorous part of the science of finance, also because quantitative) can be defined in these terms. This is an issue that has been discussed for forty years and is still under discussion, in some aspects.

That is, whether the different approach proposed here, of the tax constraint (direct or indirect taxation) is compatible with an *equal total ophelimity* for the subject if, at *equal collection* for the State, i.e. in the hypothesis of the direct tax on monetary income of the amount $T = k_1 + k_2 + k_3 + \dots + k_n$, taxes are respectively proportional to physical quantities ($x_1, x_2, x_3 \dots x_n$). It is a theorem that can be found in treatises by economists, but it gives substance to a systematic analysis of hypotheses and hypothetical case studies specific to fiscal legislation.

The constraint can be of type c) [from paragraph d) β earlier], i.e. indicative of an *ad valorem* tax expressed with the symbols: $t_1, p_1, t_2, p_2, t_3, p_3, \dots, t_n, p_n$, and can be hypothesised to be equal, overall, to a collection of extent T .

This further specification of the tax constraint leads us to reconsider from this point of view the problem of identity (or otherwise) of the sacrifice of psychological nature or repercussions in the field of ophelimity, of a collection of equal monetary import respectively, through a direct tax T , i.e. an indirect *ad valorem* tax commensurate to the *price* of used quantities $x_1, x_2, x_3 \dots x_n$.

So that:

$$R_0 = (I + t_1) p_1 x''_1 + (I + t_2) p_2 x''_2 + \dots + (I + t_n) p_n x''_n \text{ [V]}$$

that is, in the case of a single *ad valorem* rate for all goods

$$R_0 = (I + t) (p_1 x'''_1 + p_2 x'''_2 + \dots + p_n x'''_n) \text{ [VI]}$$

This is also, as we will see, a problem of public finance economics managed, methodologically, by experts of pure economics who want to proceed to real approximations through the *specification* of the *tax constraint*, which in our first hypothesis we considered as the factor determining (T), the direct reduction of *monetary* income from R_0 to R_1 .

(A whole series of specific financial economics problems has arisen, and are still current, for the explanation of the reasons and the demonstration of the economic effects of the choice of taxation, respectively specific or *ad valorem*, on goods among which income is distributed at consumption stage).

4) In turn, in the equality imagined by a theorist of political economics, T (which we have *generically* considered as the *direct* collection of income available to the taxpayer) can be hypothesised as:

e) tr , i.e. a fixed percentage quantity for every sum of net income received by the taxpayer;

f) at' , i.e. a quantity increasing with increasing overall net income available to the taxpayer.

From the specialisation or specification, according to d) and e), of the tax constraint arise the problems of public finance economics that, as we will see, lead to an explanation: of the effects of the

choice of proportional or progressive taxation, in terms of utilities subjectively sacrificed; of the modification of the distribution of income existing before the introduction of the respective tax constraint; of the modification in the events of production and accumulation of income (saving and capitalisation) etc.; of variations in presumed prices in given types of market conditions; of variations of income produced in the sense that the constraint may lead to increased efforts or abandonment of productive activity; of why target net income, gross product, differential incomes, etc.

The problems become more complicated when we introduce the hypothesis of simultaneous varying productiveness in public expenditure.

Broadly, these are the ways to approach the logic switch by *degree* of scientific specialisation from pure economics as general theory of the economic event that assigns content to the teaching of the discipline that is currently known as “political economics”, to public finance economics, performed with the methodology and logic of pure theory but which arises from the *specification* of fiscal or tax constraints of which we have examined, as way of examples, hypothetical cases.

In the course of these lessons there will be wider demonstrations and applications of this model of scientific differentiation. The specification of the constraints, strictly in the tax field, will not therefore correspond to a simple conceptual division or formal classification, but will determine other problems or quantitative theories, rationally demonstrated. They will be examined in the light of the specialisation that we have here described, within the tracks of Pareto’s vision, exposed and interpreted above. This seemed suitable as an introduction from political economics to financial economics as theory of the economic equilibrium (and from “economics” generally, as English-speaking experts would say), in the spirit of scientific specialisation to which corresponds the autonomous set of hypotheses that, for teaching purposes, are grouped systematically to teach the “science of finance”, intended in the limits of the content defined in this “Introduction”.

IX.

LIMITATIONS OF THE DEMONSTRATED RELATIVE AUTONOMY OF THE “SCIENCE OF FINANCE” FROM “POLITICAL ECONOMY” – HYPOTHESIS OF QUANTITATIVE EQUIVALENCE BETWEEN FISCAL CONSTRAINT AND OTHER RELATIONSHIPS AMONG ECONOMIC FACTORS ALSO IN “MASS PHENOMENA”

I) In 1939, when economists were already trying to update their models to explain the movements of the economic system, then under pressure from current events (mainly economic fluctuations of the 1929–35 period), and Keynes’ ideas – which now appear to be the cause of polemic in Italy as theoretical novelty – had been under discussion for some years, I stated that there was no need for the autonomy of the study of the financial phenomenon in the context of so-called “macro dynamic” models. This is the same autonomy of economic equilibrium that I have demonstrated, for the general static model, in chapter VIII, making reference to my previous work⁸⁴.

I am referring to the study (E. D'ALBERGO *Il problema finanziario e le nuove teorie economiche [The financial problem and new economic theories]*, published in the March–April issue of the “Giornale degli Economisti” [Economist Journal]) in which I took account of the attempts of some academics to explain the fluctuations of the *entire economic system* (from which derives the term “macro dynamics” that R. Frisch coined for this sort of research).

Indeed I was observing that economists normally discuss the variations of the (undifferentiated) *total amount* and the fiscal revenue compulsorily collected from the existing market economy, often on the initiative of public bodies. I wrote: “We cannot doubt *a priori* the uselessness of separating financial from economic investigations given that the laws of variation due to the interference of the fiscal event do not differ from those of variation of quantities of the changing system, which are often equivalent to variations of financial quantities”.

⁸⁴ Among them: E. D'ALBERGO – *Sul metodo nello studio della finanza pubblica [On methodology in the study of public finance]*, op. cit., of 1935.

Among authors such as Moore, Schulz, Roos, etc., who were starting investigations in “dynamics” (fluctuations of the economic system over time), I considered more appropriate not only models such as that of Amoroso for the explanation of cyclic movements, but also those of Tinbergen and Frisch, who made formal reference to the financial factor, or the vision of Keynes (*Teoria general [General theory]*).

I observed cases of hypothetical *equivalence* of the financial factor (*explicitly* mentioned) to other economic factors in the *financial wage manoeuvres* policy. In Tinbergen's work (*Les fondements mathématiques de la stabilisation du mouvement des affaires [Mathematical foundations of the stabilisation of business measures]*, Paris, Hermann, 1938), for example, these are considered *equivalent*:

1) the direct determination of wages by the State; 2) State subsidies (public expenditure); 3) the application of taxation that discriminates against enterprises (as passive subjects) according to their income.

There is the incidental consideration of the financial factor as type but it is confused with others as *one of the numerous terms* whose variation can influence the movement of the economic system, or is made equivalent to other actions of political economics. The analysis of a specific fiscal constraint is, however, obliterated and secondary without a separate and in-depth identification of a specific and overriding fiscal problem.

The previous year, the same author considered the financial factor (public expenditure) as a variation of the *volume* of investments (*An econometric approach to business cycle problems*, Hermann, Paris).

I make reference to my essay for those cases where R. Frisch considered the financial factor (collection and expenditure of wealth on the part of the public body) *implicitly equivalent* to other variations of economic quantities on the market, over time.

Of the case where the action of the State appeared to be directed to modify the “trend towards consumption”, to use Keynes' expression, by “manoeuvring” financial instruments (taxes), I wrote in 1939: “Keynes has admitted that the disposition towards saving or consumption depends on current interest and fiscal policies, also mentioning qualitative differentiations of taxation (on income, especially if discriminating against *unearned* incomes (literally, as we will see later, *undeserved*) of assets and inheritances). *Without further analytical indications*, however, the variation in the rate of interest and other factors of economic policies and, generally, the extension of the traditional functions of the State are factors with *equivalent* effects for the purposes of reaching the ultimate condition of *full employment*”.

There is very little evidence of these “macro dynamic” approaches in the financial phenomenon (type of taxation, nature of expenditure) as the *quantity* of wealth, as *total* mass of purchasing power collected and spent, is more relevant than the *method* of collection and expenditure; this is so in relation to the vision of “mass” economic phenomena, for the purpose of the construction of a general system of economic dynamics for the explanation of fluctuations in the real system.

Unless, by theoretical *analysis*, as referred to as the *method* of enforcement or the tax *category*, we mean the application, or the reference, more or less explicit, to a statistical uniformity linked to some types of taxation.

In 1933, while considering its effects on fiscal revenue, among other things relating to the more or less “rapid” amortization of public debt, I analysed the effects of using taxes on assets (“capital tax”) by hypothesising as a consequence of its application a reduction in the number of corresponding higher incomes or a “demotion of beneficiaries of income”, with the modification of the *external* Paretian curve of their distribution (already known to students).

I used a well-known statistical uniformity to demonstrate how the reduction of income from direct and progressive taxation on income could be compensated, in the overall budget of a State, by the increase in real indirect taxation on the income used or spent. I am referring to the one which can *roughly* be expressed as: the higher the individual income, the higher in proportion is, historically, the portion of income destined to consumption (of assets targeted by real taxes, for example, use of income on dwellings, clothing, tobacco (average type), salt, etc.). This is intended beyond a certain

limit of increase in income as in Schwabe's and Engel's laws, as illustrated by statisticians when teaching the introductory discipline.

For my problem (which could be defined as affecting the "mass" as it affects the overall economic system), I was interested in *presuming* the contrary, in consequence of the hypothesised application of a drastic "tax" or progressive taxation on assets, which would have "demoted those benefiting from an income from them" or decreased the number of rich people, redistributing purchasing power later to the rest of the community: that is, the higher the average income (due to demotion of people relying on income from capital) the higher is the percentage that "all things being equal, within a certain period of time, will be destined overall to consumption". In that essay (E. D'ALBERGO: *Di alcuni effetti finanziari dell'ammortamento del debito pubblico [About financial effects of amortization of public debt]*, "Giornale degli Economisti [Economist Journal], January 1933) I was interested in demonstrating the increase in the *real* tax on consumption (i.e. commensurate to the individual expenditure items and not to the whole income used by the physical person, with personal and overall tax, which we will discuss later) as *effect* of the *use* of that type of *taxation* or that *way* of collecting taxes for the amortization of public debt.

In referring to the quoted statistical uniformity, however, which Keynes, his followers and his critics have borne in mind since 1936 in considering the function of the tax for the model of full employment I will mention in the next paragraph, I intended to proceed to a real and proper autonomous analysis of fiscal (quantitative) variations. I was however *applying* or *presuming* the existence of the already mentioned statistical uniformity.

In the following models, I would not say that *making reference* to the same statistical uniformity, in the choice of the *type* of taxation to be adopted to redistribute purchasing power among the classes of those receiving an income from assets, represents, per se, *an analysis* of the effects of that tax *species*. These effects often remain implicit or are referred to in other specific studies, as it would appear from the work of many Keynesian authors.

If we bear in mind what has been specified in the previous paragraph with regard to the parallel, general model of economic *statics*, set by Walras and Pareto, that puts forward the notion of the type of constraints, we also find that there is no space for a specifically financial analysis from the point of view of economic *dynamics* as general (macro dynamic) model.

In the same essay I found it possible and more logically necessary to envisage a separate, well-identified, analytical and specific financial investigation in the model of "micro dynamics", that is, the consideration of the individual sectors of the market or individual markets or economic production and exchange relationships with analytical and specific reference to the qualitative and quantitative fiscal factor, in terms of examining the long-term specific effect in given hypothetical limitations because of it. (I matched "micro dynamics" to the model of specific equilibriums with the introduction of the *ceteris paribus* clause for the elimination of secondary "co-determining" factors, in the spirit of Marshall's visions to which I will mainly, or more frequently, refer to in the analysis of the effects of taxation.)

I refer to my quoted essay those who want to follow Barone's reasoning when he demonstrated the need to abandon the static Walrasian–Paretian model as not suitable for the study of the economic effects of enforcement. This is so because the *general* model, rather than resolving the problem, only reduces it to "equations" and "is not allowed to account for the reality of facts, in which the reasons for disorder are not isolated but follow rapidly on each other".

He intended to study (which is something I noticed Sensini had overlooked) the *approximate* equilibrium to which economies tend towards through continuous efforts by individuals in the *transitional period* of *continuous* price fluctuations, *following* the introduction of a tax. To do so he ingeniously switched from the general equilibrium model to the partial Marshallian ones when working on *Trattamento di questioni dinamiche (Scritti Vari) [Treatment of dynamic questions [Various essays]]*, vol. I, Zanichelli, 1936). I underline the term "dynamic".

2) Having demonstrated implicitly that economic and financial investigations are very similar and how, but only in part, the expert of public finance economics can proceed to analytical approximations, at least in terms of hypothetical case studies of conditions in which we presume events and the institutes of public finance to exist, it has been necessary for me to take into

consideration relationships concerning “mass” phenomena, a term used currently to define *complex* and, yet, representative events.

In approaching “mass” problems, in fact, I have tried to push to the limit the individualistic methodological spirit⁸⁵ in the following themes, in which the qualitative fiscal data or aspect rarely finds space in the formulations of economists alongside the quantitative one, in qualifying and analysing the tax constraint or public expenditure. In fact the separation of characters from the object in the approximations of the various disciplines, in the spirit of their specialisation, does not appear to be easy and self-evident in treating themes such as the following ones.

a) The “mass” problem, as I have demonstrated in the works quoted here, is the one that regards the logical-quantitative relationships between economic fluctuations of the general system and the action of the financial phenomenon in the sense of variations in fiscal revenues considered overall and in their component elements.

For this I will refer you to this study: E. D'ALBERGO: *Della sensibilità delle imposte in rapporto alle fluttuazioni economiche [About the sensitivity of taxes in relation to economic fluctuations]* (“Riforma Sociale” [Social Reform], October 1934), included in the study on *Neutralizzazione della sensibilità congiunturale delle imposte [Neutralisation of short-term sensitivity of taxes]* (signed by E. D'ALBERGO on “Rivista internazionale di Scienze sociali” [International Journal of Social Sciences], April 1935), to criticise the measures suggested by those who intend to use a “budget policy” to ensure a certain stability of magnitude, over time. This is a theme which has been revisited in these last few years by experts of both general and financial economics, as we will see.

b) Furthermore, I have made reference to a “mass” (not individualistic) problem in dealing with the issue of effects on the economic equilibrium of tax “credits”, as returns, at given times, of a quantity of purchasing power to private individuals, that is to the market, taking it away from the destination or State manoeuvre that has previously collected it for public needs. (See E. D'ALBERGO, *Teoria degli sgravi fiscali [Theory of tax credits]*, “Rivista Internazionale di scienze sociali” [International Journal of Social Sciences], 1935, to which we will come back). The hypothesis is of credits that refer to abolition of taxes and in particular to reduction of tax rates or exemptions as suggested by German measures.

c) I have made reference to the *entire market* in the theory of the indifference, with equal collection, of direct or indirect taxation in the vision that I have kept in mind while examining *general* formulations of experts from abroad and concluding in the sense of inexistence of logical relevance of the Pantaleoni's quantitative differentiation (direct or indirect taxation)⁸⁶.

These three examples demonstrate so far that the *general* model, with analysis of the effects of the destination of *global quantities* of wealth or income on the market to investments or consumption, respectively public or private, has already been used in the past in the study of public finance. Investigations by both Pantaleoni and by Barone or De Viti De Marco have also considered modifications of *overall demands* of products, overall *offers* of services and linked variations of prices on the market, due to the influence of the financial event. These can be considered “mass” phenomena: the one of “taxation burden” is a typical one.

For now this proves that the experts of public finance, far from experiencing a revolution in the context of what is referred to as Keynesian philosophy, which takes into account the explanation of the manoeuvre of *global quantities* for the determination of equilibrium over time, have already considered the financial problem in its *general* repercussions. So, when: 1) Taylor, whom I will quote later, considers the object of the science of finance to be the effects of fiscal measures on national production, on national revenue, on the quality of life and the distribution of wealth; 2) or, when Lerner (*An integrated full employment policy*, in “Quarterly Review of the American Labor Conference”, January 1946) talks of “functional” finance, finalised towards the maintenance of

⁸⁵ I have adopted the term “atomistic” which generally, in methodological works, characterises the approach that reduces all phenomena to their simplest elements in order to explain them, to indicate problems concerning the individual abstract subject, like the taxpayer, whose behaviour as entrepreneur, producer, stockbroker, consumer, saver, etc., is influenced by the fiscal event.

⁸⁶ E. D'ALBERGO – *Sviluppi di un teorema finanziario, etc. [Development of a financial theory, etc.]*, in “Studi in memoria di G. Masci” [Essays in memory of G. Masci], Milan, Giuffrè, 1943.

national revenue at a given level; 3) or, Hansen illustrates financial policy correlated to anticyclic policy for the stabilisation of the economic movement and to alleviate depression; these problems find the minds of the experts of financial economics already orientated (thanks to economics and in particular science of finance experts, who might be called “classic” or “neoclassic”) towards the vision of an overall economic equilibrium influenced by the financial event. The same can be said of models concerning *extraordinary finance*, that is, the mobilisation of greater quantities than those [suggested] in the financial hypothesis that considers non-exceptional (extent) needs of the community. These models have often embraced the logic of the entire economy (market economy, variously regulated).

The approaches that seem logical to adopt when facing the so-called Keynesian vision and other trends in studies that take account of the equilibrium of economic quantities over time, for the entire market, will be discussed, among other things, in the following sections concerning “fiscal policy” and public expenditure, and we will return to the study of the effects of taxation on the economic equilibrium and tax burden.

However, concluding now, on the basis of observations in this paragraph with regard to autonomy of financial economics as the quantitative part of the study of the science of finance, we cannot attempt to separate it rigidly, with a neat cut, from research into general economics where taxation or financial factors (collection and expenditure) are considered. There exist objectives to supply the State budget according to its needs. Among these, and without *necessarily* discussing extra-fiscal objectives, we can place the need to stabilise or increase the flow of income and the employment of workers by stimulating the purchasing power of the market via redistributions. Such objectives, as given data, are taken into account also by economics experts, especially Keynesian ones. In the light of what precedes these pages, the *specialisation* in investigations of the science of finance will depend on the degree of detail and in-depth analysis that the theorists will systematically dedicate, ex-professo and with greater approximations to the hypothesised and typified reality, on the quantitative and qualitative point of view, and on the multiple influences of the taxation factor (collection and expenditure) manoeuvred by public authorities.

X.

RELATIONSHIP BETWEEN FINANCIAL ECONOMICS AND: A) ECONOMIC AND FINANCIAL POLICY IN THE TRADITIONAL SENSE; AND B) “FISCAL POLICY” IN THE KEYNESIAN SENSE

A) Economic and financial policy is one of the disciplines taught at university. At the time when De’ Petri Tonelli dealt with this (1931), this discipline was considered a subject matter in spite of the fact that “its cognitive position is a lot less advanced than its academic position might suggest”.

I would not make this historical reference if there was not a logical significance to it. That is, it is true that economic policy and financial policy – which is of particular interest to us – have arisen as a systematic group of knowledges, after the science of finance. In addition to this chronological sequence, however, there is a logical one: that is to say that the science of finance, mainly as a rigorous treatise of the quantitative relationships that are the object of financial economics, can be viewed as a *prerequisite* of financial policy. That is not to say that the uniformities of this discipline cannot arise independently from theoretical studies of general economics or studies pertaining to hypotheses and facts of public finance. Normally, however, we make reference to uniformities already expressed by experts of pure economics and finance, to apply them more or less explicitly to problems of economic financial policy.

In other words, generally speaking, the relationship between financial economics and financial policy can be similar to that between rational mechanics and the science of construction or, as others have already described, the one between anatomy and physiology or pathology on the one hand, and clinical medicine on the other (O. Fantini).

This comparison may appear to be arbitrary and artificial in spite of the analogy here offered, which reminds us that there is no such discussion about specialisation in other sciences and taught disciplines.

Furthermore, there are no grounds for division between the investigations of financial economics and those of financial policy in terms of (economic) content and research and analysis methodology. Over and above the common characteristics of the *historical* aspects of the phenomenon, such as the inherent “coercion” of the constraints or the conflict of interests that, according to some, characterises the field in which the State acts to satisfy public needs and to achieve various extra-fiscal objectives, this link in the field of continual rationale is sufficient to exclude this comparison.

It is, however, necessary to account for the reason not only of the birth of a distinct new academic discipline, but also of a separate scientific approach to financial policy and the science of finance in the strict sense adopted here. And this is what I objectively believe I am doing in spite of what I wrote rather comprehensively in 1932, precisely in explaining a (“production”) qualification of the financial activity, that: financial activity, in itself necessary and instrumental to the production of revenue, tends to promote its essentially progressive increase when some conditions (specified in my essay, *Reddito e imposte [Revenue and taxation]*, to which I refer in the next paragraph, *B*)) arise or are provoked in the use of requirements, whose cost or effect of collection can be viewed as a decreasing consequence, or in non-fiscal activity (also called economic policy). In other words, with regard to the orientation of the financial activity that, as we will see in the following paragraph (*B*) could be defined in the current Keynesian terminology instrumental for the maximum social return (and full use of available resources), I inevitably ended up blurring the boundaries of the disciplines that have the same logical and scientific orientation, in part because of inevitable interferences of the phenomena they are concerned with.

The boundaries between the field of research of the two disciplines and sciences are difficult to identify in the immediate relationship between the objectives of State activity and the public expenditure destined to these objectives. Furthermore, often considered public expenditure is any redistribution of revenue for the achievement of *any objective* by the State.

However, to be precise, if we wanted to make a distinction in terms of hypothetical positions or points of view in formulating problems of knowledge, including public expenditure, we could differentiate between: *a*) relationships of cause and effect or functional dependence in the link between flow and type of *expenditure*, and the *effects* that are derived in terms of the individual economic equilibrium, in a sector of the market or for the entire equilibrium of the economic system at a specific point or over time; *b*) and relationships between the multiple objectives or purposes of the State and rationally efficient congruity or suitability of the *quantum* and the *type* of expenditure considered, as means whose effects are compatible with its objectives.

This second hypothetical order could benefit from the uniformities found in the first *a*) hypothetical position of the researcher of economic uniformities or of financial economics. In the following paragraph (*B*), aimed at differentiating “public finance” from “fiscal finance” in the current English language terminology, we will generally discuss the instrumentality of public expenditure as considered from the point of view of financial policy.

However, the separation of the two hypothetical points of view becomes *more apparent* with regard to the use of the objective of the fiscal instrument, that is, of the institutions that public bodies use to obtain *fiscal revenue*, for the purposes or objectives for which obtaining such revenue becomes: 1) indirect purpose; 2) incidental; 3) parallel; 4) partial; 5) *undesired effect* of the use of an instrument that is *normally* used in a logical way or with the objective of securing revenue for the State; or 6) absent or *nil* effect, as the instrument tends, in simple terms, to reduce or nullify the economic prerequisite of the collection of fiscal revenue.

It is clear that it is possible therefore to justify two approaches to theoretical research from two different points of view.

With a warning that the comparison here essentially regards differentiations of *hypotheses of study* and of *approximations* of it in respect of the theoretical examination of the concrete phenomena,

I would like to compare the two fields of research, again keeping in mind that this is a conventional approach:

a) Financial economics considers public needs for whose satisfaction the State adjusts its expenditure as “factual data”, as they correspond to time-variable functions that the State adopts for political, social, etc. *reasons* that go beyond the field of theoretical economic research.

Having said that, it objectively studies the rational elements of the hypothetical “modes” through which the State obtains revenue, considered separately and in a comparative and alternative way: public (or private or semi-private) prices for services, duties and taxes; the character of proportional and, with an appropriate incremental increase relating to the growth of incomes and assets, progressive taxation and their way of being, hypothetically; rational premises that explain them; effects on production, circulation, distribution and consumption of wealth; comparable effects of different types of compulsory (direct and indirect taxation on net or gross earnings, on income, on surplus profits) or alternative (loans and taxation) collections, etc.

At the same time it studies rational criteria of *distribution* of public expenditure, in the hypothesis that it responds (or otherwise) to the affordability principle that guides the individual in assigning available means to private needs to be met; it analyses the effects on the economic equilibrium disturbed by the collection or the “management” of means which provide the revenue, etc.

b) However, alongside the fulfilment of public needs, a constant premise of the activity consistent with the collection and expenditure of revenues – that is a financial activity in the strict sense of the word – the State pursues other objectives. These are very varied and can be of an economic, a social or a political nature in the widest sense. The State does so *also* using the instrument that is normally and primarily used to obtain such revenues. The use of the fiscal instrument can, however, deliberately prevent the collection of revenues when it affects production and consumption, or through fiscal exemptions. When Pugliese observed the systematic use of the fiscal instrument for extra-fiscal objectives, he was not satisfied by the explanation, which could only generously have been considered elliptic and not contradictory (*La finanza e i suoi compiti extra-fiscali negli Stati Moderni [Finance and its extra-fiscal objectives in modern States]*, Padua, Cedam 1932). He did however contribute to financial policy by examining the first approximation relationship between *fiscal means* and the more varied objectives of the State function (in the light of the effects of such means).

The *historical* situation that indicates that in *practice* fiscal and extra-fiscal objectives are deliberately or involuntarily pursued at the same time by managing the instruments (revenues) of the financial activity in the sense specified in our edition, *does not prevent the two hypotheses being considered separately for the purpose of knowledge*, that is, for pure theory.

For greater objectivity, I will use an example that also takes into account recent investigations by others and which demonstrates that: I) the two points of view, *a*) and *b*), can be rationally separated; II) that, nevertheless, the experts of different disciplines (in this example, the science of finance and financial policy) can approach the two hypotheses of study and proceed to subsequent approximations in the study of phenomena affected by the fiscal instrument.

As we will see later, pure financial theory has elaborated the theory of proportional taxation, which leads to taxpayers making an equal contribution, in terms of the ratio between tax and income or assets. It has done so by starting from given premises (we presume objective equality or in terms of money disbursed for tax collection). By introducing legitimate hypotheses, as we will see (and *not* pretending, as many mistakenly continue to write, *to measure* the utility of the wealth of individual subjects) with regard to the presumed method of varying the utility of available wealth, it has elaborated the theory of progressive taxation, as appropriate to the implementation in terms of utility sacrificed by individuals to the contribution of the treasury coffers.

The methods of imagining this second type of hypothetical taxation also meet the premise of equality put forward here. However, if the State wants to achieve various extra-fiscal objectives in obtaining fiscal revenues, independently from the premise of equality of the tax: levelling of fortunes or compulsory purchase of assets, (as: variation of the distribution of incomes within certain limits and in a certain way among the classes of beneficiaries of incomes considered also in relation to the

corresponding social class distinction); if it wants to achieve the Jesus Christ distribution of assets, as someone (CROSARA, *Il concetto di redditiere indifferente [The concept of the indifferent beneficiary of income]*, Padua, 1949) wrote, keeping in mind determined social *ideals*, like “preserving the proportion between pre-existing incomes, before taxation”⁸⁷, then this gives rise to very different fields of theoretical problems.

I. – Of these, the first revolves around the scientific sphere of financial economics that, on the basis of the premise, for example that of equality of taxation, as equality in terms of the sacrifices made by physical persons – determined admitted hypotheses regarding the mode of variation of utility as overall incomes and assets grow – considers all types of graduation of tax rates to demonstrate their *compatibility*, or otherwise, with the given premise. Furthermore, it can objectively examine the effects on production, or on savings, on distribution and generally on the economic equilibrium, of the presumed mode of graduating tax rates.

II. – However, Fasiani correctly observes (in “Economia Internazionale” [International Economics], May 1949) that putting forward, for example, the specific ideal or social or moral objective defined above by Crosara gives rise to two types of research, which he defines as: *a)* “if it is true that the tax supported by him (Crosara) does not affect the *natural* distribution of earnings”.

This proposition by Fasiani could be translated as follows: α) if the extra-fiscal effect of this type of progressive tax is that of maintaining the pre-existing distribution of earnings as unchanged; β) if, given the objective of not affecting the distribution of earnings, the appropriate tax instrument or means is represented by the type of proposed tax, the effects of taxation having been taken into consideration.

Normally type I) investigations indicated by me above, and type $a) - \alpha$) are supposed to have been already completed by experts of science of finance or of financial economics or are in any case carried out preliminarily from *that point of view* which is essentially inspired by the causality relationship or principle or that of functionality according to the proceedings by which the relationship between fiscal constraint and the modification of economic quantities is established.

The type of investigation identified in $a) - \beta$) normally characterises the point of view adopted by the problem of financial policy, which excludes the *quantum* of revenue which goes to the treasury.

Fasiani then defines the second order of research:

b1) – if the objective of not modifying such distribution is enough, on its own, to demonstrate the need to adopt that tax, or at least if it is sufficient for such purpose, in conjunction with some rational principle;

b2) – Another proposition derived from this order of investigation by Fasiani is the following: if the “rational” tax (in the context and significance attributed to it by Crosara) appears to conform to the objectives of a political *élite* that follows the fundamental rule of “not being favourable to anyone without prejudice to others” (an ideal that Fasiani believes appropriate for the cooperative State, a hypothetical *qualification* that, as we will clearly see later, does not lend itself to contribution of progress in this science).

Now, in my view the problems in *b1)* and *b2)* gravitate around the systematic field of financial policy. It is not without significance that the assignment of this discipline and science is recalled by Fasiani (in the discussion of what he calls “project” or *norma agenda*), as the “type of taxation proposed by Crosara”.

And this is to say that, if Pareto’s “law” (of distribution of earnings) cannot by itself dictate any criteria of distribution of taxation, it seems opportune to examine the possibility that it might give a new content to a “financial policy principle”.

Generally, progressive taxation can find instrumental application for the achievement of the most disparate non-fiscal objectives, in other words those that exclude obtaining fiscal revenues, forbidding or preventing some events, or objectives that are not primarily fiscal, i.e. they are secondarily and nearly inevitably in part fiscal, and therefore have *inevitable effects* of obtaining

⁸⁷ Assuming that this way of distributing progressive taxation is indeed like Jesus Christ suggested, i.e. that it reflects “quod superses, date pauperibus”.

revenues for the treasury, at least in part. Normally the correlation between means or instruments of financial activity and objectives that are outside its scope is the competence of the expert of financial policy in the process of *applying* uniformities identified by the expert of financial economics, or that he considers *ex-novo* and *ex-professo*, from the point of view here largely illustrated, of financial economics.

This is understood, always with the warning on the *conventionality* of this distinction, that (economic and financial) economics study the logical relationships between: I) *objectives*, the most varied that the public body commits to and that the expert accepts as “factual data”, without expressing value judgments about them, as an academic, or having an opinion about the goodness or “badness” that he perceives in them as a civil or political member of the community; and II) *means* used by the public body for the purpose on the basis of their effects, often established by instruments of financial activity, normally to reach different objectives from that of obtaining revenue and meeting expenses, that is extra-fiscal ones.

For example, the State may intervene by surrendering the right to collect taxes, so interfering in the economic relationships existing in the market: *a*) to encourage or promote and stimulate specific forms of *productive activity*, among other things, with deeds that are contrary to its own interest; that is to say in the area of revenues, by abstaining or refusing to act in a fiscal way, e.g. with exemptions from taxes of various types that would normally have an impact on the results of production or the cost of transformations.

Or the State: *β*) may “limit” in a wider sense the consumption of some products by imposing taxation on those same products for example, up to the point of making their cost ultimately prohibitive; *γ*) may prevent some sectors of investments by using taxation of the elements of production (income and earnings) in a differential way (differential taxation of some categories of gross earnings and of incomes such as those from private capital assets or differential progressive taxation of dividends) to facilitate the investment in the field of public capital assets; *δ*) may facilitate consumption through reduction of taxation or by management of public prices (as we will see), etc.

In these and numerous other imaginable cases, the State and other lesser public bodies use variations of economic quantities – whose effect on relationships of equilibrium may have been considered in pure theory of finance in abstract, that is to say, within the limits of specific hypotheses – to reach some specific or given objective. Normally the expert of financial policy uses the knowledges, that is, the uniformities elaborated by financial economics to place them, hypothetically, in a relationship with the modes of State intervention: from this would derive studies that are still based on theory, which could be defined as being applied as it uses uniformities already known⁸⁸. These are studies from which coherence analyses or contradiction of intervention “modes” with regard to “objectives” are derived.

What needs to be emphasised here is not only the logic priority of the study of causal and functional relationships *generally* of *abstract* elaborations (e.g. *regardless of the extra-fiscal objectives* the “modes” used by the State are directed to) carried out by experts of financial economics with regard to applications by experts in *financial policy*, but also the pure theoretical character of financial policy. Financial policy takes a particular point of view, e.g. that of the systematic relationship between the “means” and “objectives” of public bodies to offer a logic explanation of the intervention methods, again for the purpose of theoretical knowledge.

Making the general point for economic policy, de' Pietri Tonelli studies the variations, with political directions or State interventions, of the presumed position (production, exchange, consumption, investment, export, transport, etc.) in the hypothesis of freedom of movement from which we had started in the setting of the pure economic problem. This is on the assumption of the common premise of freedom of action in the numerous hypothetical transformations that the economic subject undergoes. In this way economic policy remains a universal science, rather than being translated into a set of precepts. “Of course the separation of theory from practice does not preclude the use of theory for *practice* and vice versa, where the analyses of social science may be useful to the synthesis of practice and vice versa, and it does not exclude that, if *not* as the only

⁸⁸ Failing these, *ex-novo* analyses elaborated along the lines of economic logic.

dominant *objective* but certainly as an *indirect* result, knowledge ultimately has an impact on practice” (*Corso di politica economica [Course of economic policy]*, vol. I, Introduction, 1931, Cedam).

Continuing doctrinarian simplification, both de' Pietri and Bresciani Turrone (*Introduzione alla politica economica [Introduction to economic policy]*, Einaudi, 1946) formulate *theories*. Broadly speaking, Bresciani, for example starting from a point of view suggested by economic analysis, and stating that “economic quantities are not arbitrary but are the necessary consequence of a set of data”, differentiates two great classes of State interventions that give content to economic policy:

Variation of economic quantities, for example some prices, that have an impact: 1) on the “data” that it changes in some ways, but leaving the market to determine of its own accord the new values of economic quantities, for example new prices in relation to “new data”; 2) directly on economic quantities, which are fixed by the authority (for example legal prices replacing market prices).

As it can be seen, these are theoretical settings, and not “advice”, that transform, as unfortunately we perceive from empirical advocates, economic policy into government “art” or into descriptive records of State intervention modes.

This is also the case for *financial policy* which from his point of view represents a step forward, an approximation in scientific specialisation to explain⁸⁹ another aspect of the actual realisation of State activity.

B) The criteria, imbued with the sense of “relative” that I expressed in order to explain in particular to students respectively of political economics, science of finance and economic and financial policy “courses” the reason why this is a specialisation and in any case of a difference of the points of view experienced by the expert of the *single* economic science; these methodological criteria, I suggest, need to be confirmed even after the so-called revolution brought about by “Keynesian philosophy”.

From what we read in the current economic literature, there has been a “revolution” or innovation as well in the field of fiscal policy, in the form of a new way of conceiving not only financial policy but also financial economics and general economics.

Experts in general theory have discussed the limits within which the expression “revolution” is appropriate with regard to classic, neoclassic or orthodox economic science. For example, I. R. Hicks (*Trade Cycle*, Oxford, Clarendon Press, 1950) stated that Keynes’ *General Theory* is essentially the “formalisation (and occasionally the super-formalisation) of the Cambridge great tradition, which comes from Marshall and Keynes, without forgetting contributions from Pigou, Lavington, Robertson and Kahn among others”. In this way the association of this tradition to Keynes’ name is a sort of “personification” (p. 4). He also quotes essential contributions by Frisch and J. M. Clark, to which I would add Wicksell and Fischer, to quote the two approaches to research (monetary equilibrium and interest theory) that opened the way for Keynes. I do not intend to give here a complete and definitive judgment on the work of Keynes not least because students and readers should know the extent of the impact of Keynesian theory from previous courses and from the treatises of political economics. I will simply briefly mention it in the notes⁹⁰ and will make reference to it in relation to some problems,

⁸⁹ All this is to be understood as referring to the *activity of the State*, and without excluding the fact that the relationship between *means* and *objective*, according to the finality principle, finds application in general or financial economics, to explain the psychological *trends* that have inspired the behaviour of *subjects*, *individually*, who are the taxpayers in our treatise according to the methodological warning indicated in *c* of Chapter III of this *Introduction*.

On the other hand, economic and financial policy can study effects and variations of economic relationships, in function of State interventions or causal relationships with them: an investigation which is in any case logically *necessary* for the evaluation of congruity between means and objectives.

⁹⁰ Without doubt, Keynes’ position expressed in *General Theory* with regard to the “classics” should be commented on, as I explained in my article in the magazine “Economia Internazionale” [International Economics]: E. D'ALBERGO, *Effetti delle imposte e teorie del “full employment”* [Effects of taxation and “full employment” theories], August 1948, and in the “Rivista Bancaria” [Banking Journal], when I introduced the

such as for example the effects of taxes, contributory capacity, fiscal burden, etc., in the following chapters.

It is certain however that Keynes did not bring a “revolution” to the concept of financial policy and financial economics (that is, *public finance*), whose respective points of view in considering the object of State financial activity, with fiscal or extra-fiscal objectives, are not at all

French edition, issue March–April, 1950, and not only for the reasons reported there. This is also because I cannot refer to other interpretations of the criticised classic hypothesis of full employment that Knight considers to be a “caricature” and Pigou a travesty, as a premise, according to his comment about Keynes’ *Employment and Equilibrium*, p. 86. In the vision of the classics, in their rigorous form, *full employment* does not always exist, but there is always a trend towards it. Generally speaking it does not exist (that is: it would be an absurdity to assume that it exists on average), but in the absence of factors which disturb the market *full employment* always exists. In actuality the forecasted disturbances maintain the system in some way short of this condition of full employment.

Keynesian critics state that the “trend”, in terms of degree, leads to *relevant* movements away from full employment, in the sense that equilibrium settles spontaneously at a point much below the condition of full employment.

Another issue is the criticism of classic theory, not so much because of its logical errors but to “highlight the fact that its implicit hypotheses have hardly ever been verified”. After our premises in this introduction, the legitimacy of this criticism could be debated in the light of scientific methodology. Thus did Keynes express himself in the closing paragraphs of his *General Theory* treatise, p. 392, French edition. The same author feels the discomfort of criticism from this point of view when he warns that if public authorities can manage to establish a production volume as close as possible to that of full employment, “classic theory would be vindicated”: and that “if production is taken as given, there is nothing to object to in the analysis of this school of thought”, etc. Income as a dependent variable is used in finance.

Further to G. B. Say’s “law of market”, according to which, briefly, all goods produced are sold, i.e. that the offer necessarily creates its own demand, there has been an exaggerated appropriation of this concept by classic and neoclassic economists, especially as these latter ones have studied the problems of unemployment, of cycle and fluctuations generally, as Haberler observed. So that, according to Pigou, Keynes would have attributed the error to *everyone*, hypothetically assuming that this is an error, which is something I think of more than one. While, on the one hand there are enthusiastic supporters of the Keynesian revolution, of the “Bible” of economic thought, etc., and on the other, there is aprioristic or hurried criticism, it is interesting to note that many of those, who were critical in 1936, have changed their mind a decade later, giving some credit to the thought of those who believe that Keynes’ views will be better understood towards the end of the century. I will express my professional views of Keynesian theory another time. For now, I will incidentally note:

a) If it is true that according to J. R. Hicks Keynes has “exaggerated” the importance of interest theory, it is nevertheless to be recognised that new thinking in this area now considers it as a variable that balances the offer and demand of *money*; b) similarly the dynamic theory of expectations and the predicted discount factors that can influence the marginal efficiency of capital, by keeping track of fiscal and monetary factors, in itself contributes to completing the acquired static theories of marginal productivity of productive factors; c) the attempt to link the monetary phenomenon to economic equilibrium, following Wicksell and his school, and overcoming the isolation of traditional “quantitative” theory from a large part of remaining facts or remaining relationships between economic quantities is indeed remarkable; d) the essential psychological “propensities” that explain the effects of the behaviour of savers and consumers in particular contribute to the explanation of volume of investments and level of earnings, in part through the generalisation of Kahn’s “multiplier” concept. A concept, this, that had been moreover rigorously specified but that was known and used implicitly in previous models in the study of the effects of public expenditure. A contribution to this can be found in the study of “propensity” to consumption, as Kahn develops Marshallian concepts with regard to the presence of earnings and the unwillingness to spend. From this derives lack of confidence and, therefore, the depression crisis.

Keynes offers a contribution stimulating at least studies in this area, with regard to an explanation of the variations of economic equilibrium in short periods of time, shedding useful light for those who, like J. R. Hicks, continue with the theory of economic cycles. Even though I reserve my definitive judgment on this to another time, I presume that further studies will probably confirm these points for me. That is to say that they consider facts relative to the global system: production, consumption, investments, income, etc., have given us specific theories in those fields which are thought to be the main ones. Furthermore, the *ceteris paribus* clause is not absent and often it explicitly and implicitly limits the treatise where some quantities are considered *data* from a certain point of view and dependent and independent *variables* from another.

overturned or changed by the still significant attempt to assign economic theory in the hypothesis of a *trend* to a condition of full employment and maximum production of social earnings.

According to Keynesian enthusiastic supporter G. Colm (*Fiscal Policy in New Economics*, edited by S. E. Harris, London, Dennis Dobson, 1949), it would not be possible to think of fiscal policy, as understood in the modern world, without remembering Keynes, who gave a “new meaning” to this conceptual expression. According to Colm, Keynes used the term “fiscal policy” rather than the conventional one of “public finance” (under which heading falls what we know as the science of finance) to signify that he dealt with “one aspect of public finance”. And, as we recognise that Keynes did not give us a definition of fiscal policy, we are trying to derive one such definition from his work, in the following terms: “fiscal policy” is a policy that uses “public finance” (intended as *fact* and *object* of the corresponding theoretical science) as a factor of equilibrium in the development of the economy or in economic dynamics.

Let's leave aside the redundant question of “novelty” of the meaning and of prior use of this expression or of its reintroduction in modern use by Keynes, partly because the same Colm did not appear to insist on this in another text (*Fiscal Policy in Economic Reconstruction*, in the volume of the same name: *Economic reconstruction*, edited by Harris, McGraw, London, 1946, p. 253) where he limited himself to stating that it was of recent use but yet widely accepted.

If at all, it can be conceded that, according to another enthusiastic Keynesian supporter, who calls it “revolutionary”, the *objective* of fiscal policy is a novelty. (Hansen: *Fiscal Policy*, 1941, p. 17). This is however the purpose *not so much* in reality but in what Samuelson defines as “positive fiscal policy”, which deploys taxation and public expenditure to neutralise fluctuations in the economic cycle, a problem that, as I said in Chapter IX, was already of interest to myself and others; or to contribute to maintaining a practical or historic economy, a progressive one, with great use of productive factors, and free from inflation and deflation: *in theory*. That means for the purpose of knowledge, as an explanation of the State activity as a factor of equilibrium of the system or “State action as a balancing factor” (as can be read in *General Theory* by Keynes, on p. 220). In fact this is intended as the “fiscal policy” of the action limited to the use of some events and institutions of the financial activity.

I say this also because the same Hansen, referring to “compensatory fiscal policy” as tending to neutralise cyclical fluctuations and to the achievement, as a “deliberate objective”, of the stability of the economic system characterised by full use of productive factors, states that the great advantage of such (fiscal) policy consists not in the implication of “new procedures” but in a rational and purposive use of them in the financial field. (*Economic Policy and Full Employment*, London, McGraw, 1947, p. 209).

I believe that these references to the literature, which are not controversial but relate in particular to Keynes' followers and admirers, allow us to debate that there are no reasons to believe that the methodological criteria which assist progress and the specialisation of studies and teaching disciplines should be modified with respect to what has been stated previously in this *Introduction*.

To allow readers and students in this field to draw their own conclusions, I will refer in this regard (to conform with *General Theory*, or the French shifting of it I have to hand while I write this paper) to the fact that Keynes, the “creator” of “revolutionary” philosophy, does take into consideration the fiscal factor.

a) With regard to the “objective” factors that influence the trend or propensity to consumption, Keynes identified the *variations of fiscal policy* (Volume IV, Chapter VIII, n. 2) among the “main” ones. The impulse that encourages individuals to save, as a function of the future income they expect from these savings, clearly depends not only on interest rates “but also on the fiscal policies of public powers”.

Taxation of income, especially if it differentiates income that has not been earned (in the terminology here adopted, we should say when it discriminates against income “based” on use of capital in the sense that we will specify later), taxation on surplus of capital and on succession, among others taxes have an impact similar to that of interest rates in terms of encouraging savings.

b) It is also feasible that possible variations in “fiscal policy” have a greater impact than that of interest rates, at least in forecasting terms.

c) When “fiscal policy” is deliberately used as a means to achieve a more equal distribution of income, at that point it has a greater impact on increasing the “propensity” or trend to consumption.

d) It is also necessary to take into account the impact on the global “propensity” to consumption of the sums collected through ordinary taxation and used by the State to pay off its own debt. These sums represent a form of collective savings and in these circumstances a significant amortization policy must be considered appropriate to weaken the “propensity” to consumption. It is for this reason that a change in State policy that expects amortization after incurring debt (or vice versa) can lead to a significant contraction, or a significant expansion in the opposite case, of the “actual demand” (that is the sum of expenditure on consumption and investments in the same way as businessmen forecast them when they set employment volume). The quotes above are drawn from pp. 111 and 112 of the French edition of *Théorie générale [General Theory]* (Payot, Paris, 1949).

e) Keynes deals with the effects of “public works”, that is, a certain type of public expenditure, taking into account the source of finance for expenditure and the conditions of its employment from the point of view of the “multiplier” theory, in terms of the functional relationship with “marginal and average propensity” to consumption and with global employment (Chapter X).

f) Given the ability of the State to calculate the marginal efficiency of capitals⁹¹ with far-reaching forecasts in the social interest of the community, we expect it to take an ever growing responsibility in the direct organisation of *investment* (p. 179).

g) Finally, in concluding the volume and talking about “social philosophy” (Chapter XXIV) Keynes deals with “fiscal policy” through a system of direct taxation that compels financiers, entrepreneurs and other businessmen to put their intellect and professional abilities at the disposal of the community, upon reasonable conditions. He also deals with *extensions* of the “traditional functions of the State” to influence “propensity”, respectively, to investment and consumption.

Now, let’s consider these propositions carefully. We will notice that, in the light of the preceding methodological criteria with regard to specialisation of disciplines and sciences, they do not contrast the respective objectives of: 1) political economics or “economics” or pure general theory; 2) the science of finance as public finance economics; and 3) financial and economic policy, this latter an expression that can easily be reduced simply to Keynesian “fiscal policy”, as I will demonstrate.

I) In fact, first of all let’s consider the position of the fiscal factor overall or as a *type* of constraint, briefly; it could be said (as in comparison with the static, Paretian model) in relation to the equilibrium conceived, for example, as Keynesian followers would have it, as balanced economic expansion.

We know – briefly – that classic or “orthodox” theory, which includes developments that come under the heading of “neoclassic” economics, presumes full employment of all resources available on the market. With regard to this condition, the case of “under-employment” is considered a temporary exception that finds the theoretical possibility of automatic rebalancing in current economic forces.

In the Keynesian concept most appropriate to explain real events, we presume the possibility that the equilibrium is determined at *any* level of economic factors used, depending on consumption and investment or “effective demand”. The view that current followers of this approach take into consideration is that the system is not exactly balanced with *full employment* of resources or factors, but simply *tends* to this condition, remaining fairly distant from it. From this arises the need for a “doctrine” that studies how to stabilise economic development, in the context of its cyclic nature and considering the *trend* or long-term trajectory.

Among the *numerous* factors to be “managed” or whose variation can hypothetically be influenced by external factors, “fiscal policy” (in macroeconomic terms) is considered a “balancing factor” to “preserve the capitalistic system” as a type of mixed or eclectic economy, without excessive direct control over it and with a minimum of direct State control of private initiatives, in a vision that goes beyond “must be” and that wants to represent “general economic theory”. The fiscal factor is

⁹¹ The marginal efficiency of capital is the discount rate that indicates the actual value of the series of annuities made up by the discounted returns of the supplementary unit of a given capital, equal to its cost of production or offer price.

seen as *one of the constraints*, in the *armamentarium* of elements and factors that contribute to the equilibrium of the system.

Now let's consider Keynes' references on papers on "fiscal policy" *considered from this point of view*, and we find that in this theoretical construction (whose comparison to the traditional and neoclassic vision can be summarily described) of the fiscal factor it is possible to observe:

- a) the overall *sense* of how it can be a "balancing" factor for the whole system, over time;
- b) the type of constraints, in fiscal terms, represented by direct (essentially progressive) taxation on incomes and capitals, or indirect taxation (successions) on assets, with the objective of redistributing purchasing power, taking away from those who have more to give to those who have less, to reduce savings and increase consumption;
- c) the *equivalence* between variations of the fiscal factor and other variations or management of factors with *more or less* equivalent effects (interest rate, for example);
- d) issuing and repayment of public debt for the generic effects on the overall equilibrium, for the variation of consumable quantities and redistribution of purchasing power through State decisions.

As it can be seen, the incidental but still significant *reference* by Keynes to fiscal policy (as a *device* suitable to manage global quantities on the market, as an explanation of the re-establishment of equilibrium, not simply through traditional automatism) cannot constitute carrying out an *analysis* of financial institutes and events, as properly and traditionally done in the field of the science of finance.

G. Cohn (op. cit. p. 453 in *The New Economics*) rightly states, even when showing his admiration for Keynes, that "Keynes does not discuss issues and problems of public finance" as such, that is to say the problems studied by those whose competence it is to deal with the science of finance and financial economics. This position is not dissimilar from that illustrated by Pareto with regard to the fiscal constraint.

II) Followers of Keynes' theory, however, have a more correct concept of *public finance* or of the science of finance when they do not confuse it with financial policy.

I will refer to Taylor, already quoted. By *public finance*, this author implies the systematic study of the finance of an organised group in the State institution. State finances are concerned with income and expenditure. We can talk about fiscal or treasury operations.

With regard to *whether it is a science*, however, we can consider it a fiscal science to examine fiscal problems. However, this should be done with the pure and neutral methodology of science. This means that, given specific financial premises (income and expenditure), it applies (p. 6) the techniques of *economic analysis* to the materials just now limited of public finance. "This technique or analytical theory with economic character is essentially what logically proceeds by relating causes and effects, by isolating the various forces that act together to determine the behaviour of the economy as a system".

Taylor therefore intends to carry out economic theory by dealing with the problems of public finance. It is to be understood that the relationships of interdependence studied by this science are not to be excluded. (See Chapter II, *d*) of the *Introduction*).

And yet, from this point of view, he deals analytically or through the effects not only with the traditional issues that regard the rational content of the respective and alternative "modes" of collecting ordinary and extraordinary revenues, also resorting to public debt, but also with the issues that interest the economist who chooses as his object the themes of Keynesian thinking. In fact he deals with: 1) "pump-priming", as an occasional system of State intervention to input with a non-uniform flow, when expenditure rises, additional purchasing power on the market, with the effect of bringing the economy to the full use of resources, leaving the system to proceed *on its own, without additional State expenditure*. He further covers: 2) "compensatory" State activity through the system of "deficit spending", systematically, in the hypothesis of the State as "auxiliary motor for the economy", in addition to compensatory activity for cyclical fluctuations, recurring to lending and taxation as well as of available unused assets (hoards), etc.; 3) effects of public expenditure in the context of variations of marginal "propensities" and with the application of the theory of the multiplier (issues to which we will refer later in these lessons). These and other issues of "functional finance" are considered by Taylor according to the methodology expressed earlier and from the *point of view* of the science of finance, that is to say irrespective of extra-fiscal objectives and considering

relationships of causes and effects and interdependencies in light of the fiscal factor as isolated and related to distinct hypotheses of market conditions.

I have focused on this approach because it is significant, in as much as *A* links the traditional treatment of financial economics problems to the re-examination of themes that have arisen from the study of the economic cycle carried out by monetary economists, as a contribution to *public finance*. He also makes reference to Keynes, Hansen (whose terminology he adopts), Samuelson and Harris among others.

As testimony to the differentiation of (α) “public finance” (as a State activity and essentially economic theory for the purpose of knowledge) from (β) “fiscal policy” (as action and observable relative solutions by economics experts from *a different hypothetical point of view*), I will also recall the recent edition of the “public finance” treatise by A. G. Buehler (McGraw-Hill C., New York, 1948 edition).

a) This author, even though up to date with regard to applications of the Keynesian vision of the *instrumentality* of State income and expenditure for the rebalancing of the economic system over time, considers *public finance* – traditionally corresponding to the science of finance – as the study or science whose objective is to consider the distribution of expenses, the collection of funds, or method of collection, of loans and other systems, and the financial administration of the State. More concisely, public finance is the financing of public needs that are met by the State. “It is the task of the *public finance* expert to examine the *principles* and events of State financing and study the relative economic and social *effects*”.

β) The same author views *fiscal policy* as “planned” or rather reasoned and pre-ordered *use* of public expenditure, of public lending and fiscal taxation as well as financial administration to *achieve* financial *objectives* such as: full employment, an equally distributed growing national income, the neutralisation of inflation and deflation, etc. The relationship between *means* and *objective* belongs to the activity that provides historical content to “fiscal policy” and to the theory that systematically studies it, from the expected point of view of economic and financial policy, also in Buehler vision. If it is apparent that “the study, the principles and the issues of *public finance* have grown in significance”, it is also clear that they have done so because they are applied to “fiscal policy” to make it “planned”, or rather thought out and rationally pre-ordered in the spirit of the logical Paretian actions of *means* and *objectives*, whose systematic analysis, as scientific specialisation, leads to *financial policy*. *This is so* always with the necessary warnings on the non-rigid and absolute differentiation of the object of these branches of economic science, whose hypothetical viewpoints are however here distinctly opposed as views from which theoretical problems are set out. Samuelson (op. cit. *Economics*) comments on the growing historical importance of State functions, and adds: this explains why “no modern economics manual can ignore the vital and important issues of public finance”. So: *a)* either he handles them, even if briefly, according to *traditional* settings, that is to say as analysis for the purposes of understanding the various relationships between variations of quantity correlated either instantly or over time; *b)* or he returns, with regard to these issues, to the specific treatments of the science of finance, even while suggesting problems of “compensatory” anti-cyclic State action, keeping in mind “positive” examples of fiscal policy orientated towards the equilibrium of the system in the short and long term.

Samuelson is a Keynesian economist. It is something else if the same person extends the hypothesis of economic theory more or less to the specific field of interest of public finance theorists; and something else again to say that there is a *conflict of points of view* on the part of: 1) those who study the equilibrium of the system over time, also as a function of the fiscal factor; 2) those who analyse the effects of “modes” of using the fiscal factor and the *quantum* of its management; 3) those who consider relationships of *means* and *objectives*, that is to say who implements “fiscal policy” as financial policy, as it has been introduced in letter *A*).

Keynesian followers Hansen, Blough, Colm and also Harris say that they consider taxation not from a fiscal point of view and then later they declare to be interested in the study of the *effects* of a given taxation system on enterprises, on consumption, on investment, on the employment of factors, on incomes and total expenditure. But in that way they are not rejecting the logical and methodological position of the traditional science of finance or of public finance as defined in

English, even though they are thinking essentially of “mass” problems. Chapters by all these authors in the volume quoted and edited by Harris (*Economic Reconstruction*) are proof of this.

This work covers: *a)* the effects of reduction in taxation; *b)* taxation of unemployed “funds”; *c)* taxation of trend’s earnings; *d)* the effects of public expenditure; *e)* the effects of taxation on the reduction of consumption or of productive activity; *f)* reduction and accumulation of public debt; *g)* taxation of companies (earnings and reserves); *h)* or successions, etc.; this demonstrates, additionally when facing real problems, how essential research is for the purpose of knowledge, according to traditional and hypothetical models of financial economics.

From this point of view Lutz is mistaken when he states that “compensatory” financial concepts are “alien doctrines” or irrelevant with regard to the stabilisation of the system, if by doing so he intends to exclude them from the object of the science of finance, that objectively studies cause and effect and quantitative functional relationships, irrespective of the objective for which investigations are used, even when the fiscal instrument is finalistically managed for general economic policy objectives. (*Public Finance*, New York, 1947).

Allow me to make reference to a study carried out in 1932 where, faced with traditional visions that considered a “mode” to distribute taxation (which affects the economic equilibrium *to a lesser extent*) neutral, excellent and productional, and that ignored public expenditure and its effects, I suggested criteria that I briefly summarise here, to simplify a study hypothesis. I intended to deal with the general theme of financial economics, clearly with the vision of one who illustrates a rational criterion according to which it is possible to perceive the trend “mode” and “quantum” for collection and expenditure, with a necessary reference to an overall quantity, that is to say the collective revenue, as an entity variably influenced (effects) by public income and expenditure.

In this sense I have no difficulty in classifying the 1932 essay, when Keynes’ terminology was not yet fashionable, as having financial theory or public finance economics as its specific object (E. D'ALBERGO, *Reddito e imposte. Saggio critico sul produttivismo nella attività finanziaria* [*Income and taxation. Critical essay on productivism in financial activity*], in “Rivista Internazionale di Scienze sociali” [International Review of Social Sciences]).

Keeping in mind that today we often reason in terms of income as an essential dependent variable (some people refer to the “new” science as “income” economics), we can confirm the relevance of the model in which financial activity is seen as indirectly instrumental in relation to the maximum production of social income.

We can translate into current Keynesian language propositions such as the following ones, in which the classic vision of the collective *optimum* consisting of “not changing anything in the economic equilibrium as a snapshot of a specific moment, including the distribution of wealth” is overcome. (A. CABIATI: *Osservazioni sul “principio produttivistico”* [*Observations on the “productional principle”*], discussed by Einaudi, in “Riforma Sociale” [Social Reform], 1927).

Having considered the methodological hypothesis of limitation (of the study of the problem of relationships between the financial event and collective income) inadequate for a more approximate vision of reality, I put forward the following propositions: *a)* that the maximum accumulation of savings is *optimal* or ideal or debatable for society; *b)* that in any case greater savings can be considered the effect of a greater income, to which it is linked and which conditions the formation of new capital; *c)* that the maximum accumulation of savings must not necessarily presume a progressive decrease in consumption; *d)* that a variation to the economic equilibrium is preferable to its stability, even if through fiscal redistribution of wealth, from the rich to the poor, as a condition compatible with the increase of prosperity or of social income that productional finance must maximise, in a finalistic manner however, that now others define “functional”; *e)* that the redistribution of means that the State collects and spends can enable subjects (especially producers or entrepreneurs as Paretian speculators) to take advantage of favourable circumstances created by the “productional” financial activity. (Characterised by collection and expenditure according to needs with redistribution of purchasing power on the market).

The equivalence of the Keynes’ concept of “effective demand” can be identified in the sum of expenditure on consumption and investment that was suggested by my model, aimed at considering the effects of facilitating the activity of entrepreneurs while also redistributing wealth. The

terminology of the accentuation of the “propensity to consumption”, as we would say today, is missing but the concept was implicit in my reasoning. Furthermore, this vision was supported even though at first it might have appeared to be a financial activity of the type, “cost for some and advantage to some others”, given the final result of increase in social income.

I return to the essay, and I was interested in classifying it, as an example, among the *current* ones orientated in the same way, in the context of “fiscal policy” or of general theory which *presumes* the management of public income and expenditure as coherent instrumentality. I don't mean that those arguments were exactly of a Keynesian type: I say that because I don't want to say “*nihil novi sub sole*”⁹².

However, it is certain that if this reasoning were to be translated into Keynesian terms, treatises would not be in contrast with the models we insist on now in the field of general and financial economics. That is to say, in the understanding that we keep in mind the enunciation of a maximum relationship between a maximum of the financial activity and a maximum social income (an alternative concept or a concept compatible with that of “full employment” in Keynesian terminology).

It was, as we can see, a science of finance investigation or with the objective purposes of knowledge or of theoretical uniformities. Furthermore, from this essay a *finalistic* approach transpired (that is, looking for means to achieve the goals, which is the typical financial policy's *point of view*); and the “must be” was equivalent to a hypothetical language.

III. – Finally, no further comments are necessary as to the case of “fiscal policy” understood as financial policy, as we clarified in letter *A*) of this chapter, that is to say in the traditional sense: in other words, the analysis of the relationship of *means* and *ends*, or the congruity of means to the end, in the study of “functional finance” or behaviour according to what Pareto refers to as logical actions, i.e. *directly* orientated to the achievement of specific objectives, not the *exclusive* one of achieving an income for the State or that is associated to other simultaneous non-fiscal objectives, in the sense explained in the already mentioned paragraph *A*).

We often read in current literature from abroad about expenditure, taxation or loans orientated towards *objectives* of stability of the economic system in a vision of full employment of all factors and resources, that is to say of instruments and modes of the financial activity directed by a conscious purpose, towards a deliberate end. Others talk of “rational” use of financial quantities.

We could not use terms such as “rational” or “conscious” in dealing with means and ends, if we did not *presume* an abstract or hypothetical analysis that transcends the history of individual countries or markets, to consider such *finalistic* relationships between fiscal and economic quantities, from the point of view that, as we have seen here, is specific to economic and financial policy.

In conclusion with regard to this chapter: the study of current theoretical trends, which gravitate around Keynesian studies and those who promote and criticise and the forerunners of this approach, allow us to confirm the logical legitimacy of these three points of view from which financial activity as a fiscal constraint can be scientifically observed, justifying three systematic disciplines. This should clearly be as to avoid having hermetically sealed areas or artificial separations, be they subjective (the same academic could be interested in all three areas of research that essentially all deal with economic theory) or objective in the sense that in works formally assigned to one of the respective disciplines can be found studies that, for reasons of explanation of the scientific specialisation, we have included here without a clear delimitation of competence in theoretical research.

⁹² Jannaccone first, in the volume on G. Law, even though indirectly, as I have demonstrated in my review in *Rivista Bancaria [Banking Journal]*, 1948, and then L. Federici, in the lecture on the course of political economics at the University of Modena, commented how ideas, intuitions, concepts and demonstrations similar to the current Keynesian type were too widespread in the past to be able to claim priority and novelty in viewpoints in this subject.

XI.

THE RATIONAL CHARACTER OF THE STUDY CARRIED OUT IN THESE
 LESSONS OF PUBLIC FINANCE ECONOMY

The definition I have given of the science of finance, with regard to quantitative (economic) content, allows us to avoid the often factitious search, in the frequently vain attempt at originality, for a “specific setting” or a specific “model” to explain the financial phenomenon.

When I talk and write about “public finance economy” I refer to the scientific and objective study that does not require additional qualifications. It is a neutral study in the sense that it excludes subjective preferences or feelings, interests or value judgments, and in that it deals with the field of economic logic, whose hypothetical science methodology and vision it continues, with regard to quantities influenced by the specific constraint given, for example, by fiscal legislation. This is so not only with regard to how it is enforced in given countries, but also as it can be imagined in an abstract order, without any historical reference or type of State, but rather in terms of economic conditions within which the fiscal constraint operates. If anything, the term “rational” could briefly summarise the characteristics of the study carried out in these lessons of public finance economy.

Having clarified this, I don't believe it is necessary to have a specific *setting* (with the presumption, expressed by some, of being able to explain *all* aspects of the phenomenon) or a declaration that qualifies these investigations as being completely focused around “concepts”, “models”, “approaches”, “schools” or similar sets, which are not important for the progress of a science superior to that of individual *hypotheses*, that illustrate aspects and modes of the financial activity but does not explain them *all* coherently. In our field this progress is, in my view, characterised by the greater or lesser aptitude of theoretical research to logically explain institutions and financial systems and their effects, from given points of view, of which the economic one is adopted here.

I say this without wishing to offend those who, in tracing the historical development of this discipline, have classified my essays as pertinent to the “neo-economic” concept of finance. This classification would probably be confirmed by the nature of this course but, as I stated in the preface of the first edition of these lessons (1942), I do not believe it is important in itself with regard to theoretical problems.

Among others, I refer for example to Griziotti who, in introducing the bibliography of the science of finance and of financial law, in the series of the national institute for cultural relations with foreign countries (I.R.C.E., Rome, 1943), indexed some essays, as being “closer to the character of the first group” of contributions, ahead of those of a group of contemporary academics (d'Albergo, Paolo Ricca Salerno, Papi, Masci and Arena). De Viti De Marco, Graziani and Einaudi are authors representative of the first great current of study, characterised by the following note: “extreme elaborations of financial economy, which fine-tune the theories expressed in the last 15 years of the last century”.

Nor do I wish to criticise those who, on the basis of their own criteria, have placed the approach in my view of the financial phenomenon in the context of the so-called sociological concept of finance, probably mainly on the basis of the essay I wrote in 1932 (E. D'ALBERGO, *Intorno al concetto di costo della attività finanziaria [On the concept of the cost of financial activity]*, in “Annali di economia” [Annals of economy] of Bocconi University, Milan). In that essay, without waiting for the death centenary of the great Pareto to awaken interest in his professional views on the science of finance, I demonstrated the ability of his logical vision of the maximum utility *for* the community to explain the genesis of the calculation by the governing class, on the basis of which revenues are collected from the wealth of the same community and are spent for the fulfilment of public needs, as I have more explicitly highlighted in the two previous editions of these lessons.

We will discuss later this position of the Paretian sociological model in terms of explaining the “how much” and the “how” of collection and expenditure on the basis of the judgment of the governing class carrying out calculations for the community. For now, I confirm that the definition of the science of finance consciously adopted in these lessons corresponds to a way of seeing problems

for *what they are and for what can rationally be said about them from an economic point of view*, as it does not require any “setting” to be qualified according to the traditional mode of classifying scientific research. This is still the only approach that allows lines of reasoning that are not totally uncritical and that are similar to those prevalent in positive and exact sciences.

Gangemi, who considered my essay, and perhaps other “suitable works”, inferred from it “d’Albergo’s acceptance of the economico-sociological concept as it takes into account social factors in the study of financial problems (sociological evaluation) and of the collective financial phenomenon as already formed and detached from the forces that have determined it” (the economic aspect of the financial phenomenon).

Furthermore, I intended to differentiate the *genesis* of the financial calculation from its *content*. Politico-sociological genesis, even if enlightened by economic quantities, does not in fact prevent the academic from considering analytically the relationships between economic quantities, once the financial calculation has been carried out by the competent authorities. This explains the concepts that Gangemi derives from other essays (preceding editions of these lessons) when he writes: “Ernesto d’Albergo does not believe, with regard to the treatment of financial theoretical problems, in the importance of *the setting of a model in order to explain the financial phenomenon*, when it claims to treat all financial events in the context of a single general model. This is so because, when examining various treatises and “courses”, it is extremely rare to find that the economic, sociological or politico-juridical premise is suitable to explain, in a harmonic, coherent and continuous way, all the facts of financial activity”. (L. GANGEMI: *Elementi di scienza delle finanze [Elements of the science of finance]*, vol. I, p. 59, Naples, Jovene).

It is for these very reasons and for those that follow that I am sceptical about declaring allegiance to “schools” or “concepts”: Gangemi recalls this, with reference to my work, where I state that “such *courses*”, or treatises, include a series of rational problems that need to be solved in any case – regardless of the “school” to which the academic declares allegiance – in the light of the *economic theory* or the *orthodox juridical theory*. These are two aspects that, until now (because they are not mixed up in an irrational way, could be examined for the purposes of public finance.

There is absolutely no reason, on the basis of my subsequent experience, be it in the teaching or scientific field, to change my view. This was aptly understood in the following quotation because it gives implicit emphasis to the objectivity of the scientific research that was clearly understood as being fruitful and outside of subjective preferences that can sometime be ideological, non-critical and sentimental. With this aside, in fact: “Without consideration for the classification in the one (economic) or the other (politico-juridical-social)” the 1944 course of lessons by d’Albergo is recommended⁹³.

A first consequence of this theoretical position is that it reaches an objectivity of research that allows, in my view, an explanation of the events of any historical *period*; therefore it is compatible with any hypothetical *type* of subject of the financial activity (State and lesser public bodies or similar). The research for logical and coherent content derived from arguments on the mode of obtaining revenues and apportioning expenditure is intended to be free from links (necessary according to some) to types of State and orientation of the governing classes to whom positive orders tend to correspond in reality.

In support of this scientific position of mine, the implicit view of De Viti De Marco with regard to the limited fruitfulness and, as will be demonstrated, the inconsistency of aprioristic models with which the financial phenomenon can be rationally explained seems cautionary and rich in methodological meaning. I refer to the involuntary demonstration that De Viti offered about the lack of necessity for general concepts, that presume to summarise logically the events that are the object of the science: a demonstration consisting of the *substantial abandonment* of typology (monopoly and popular State) of subjects of financial activity, after having suggested it as a promising logical key (then no longer used) for the admirable theoretical treatment of the financial phenomenon and the individual institutions, in which it manifests itself. I am referring to *Principii di Economia*

⁹³ In a note to Roepke’s volume – *Spiegazione economica del mondo moderno [Economic explanation of the modern world]*, Rizzoli (Editor), Milan, 1949, p. 38.

Finanziaria [Principles of Financial Economy], the 1934 edition, edited by G. Einaudi. So we have an extension to public finance of the concepts of monopoly and competition that characterise the functionality of markets as considered by political economy. *Stato assoluto or monopolistico [Absolute or monopoly State] (A)*, as a hypothetical subject viewed as a limit case, in which “a class has the right to, and de facto, monopoly of government”: “and this – explains De Viti – allows it, in the creation of public assets, to choose redundant ones for its own exclusive or predominant benefit, and to charge the others exclusively or predominantly to subject classes”. “In other words, *mutatis mutandis*, the case of a private monopoly is reproduced in a financial economy. In different forms – that need to be researched and defined – the governing class profits from and the governed classes pay the price of the monopoly”.

To a type *A* State De Viti compares the type of *popular* State in which “the premise is given that, in the free competition of social groups and parties, each class can reach power and, having achieved it, remains under the scrutiny of the community”. “So, at least in *pure theory*, the typical conditions of competition are realised”, market conditions that are characterised by the fact that “at any given time, a producing group can be *replaced* by another, drawn from the mass of consumers”.

De Viti continues: “It is enough to imagine that the succession of groups to government occurs with sufficient rapidity to reach the limit result of considering groups that in turn govern or are governed as being practically identical”. “This recalls precisely the concept of cooperative”. “We can consider – concludes De Viti – the democratic State (*B*) as the one that comes closer to the economic model of cooperative”, “as all citizens who pay taxes are also the citizens who use public services”. “This theoretic concept has its historical basis in the principle adopted by all *modern* constitutions (do be careful with this qualification as we will soon see it used for another type of State by Fasiani) according to which taxpayers vote on taxation”. “In the two hypotheses it is a necessary consequence for the popular or cooperative State to provide public services at cost price”.

De Viti suggests that in pure theory “it is possible to study financial phenomena”, in the two hypotheses *A* and *B* of political constitutions. But in real theory (in the sense that financial economy “tries to get as close to reality as possible and therefore attempts to study the real phenomenon, taking into account all the factual elements it comprises”) it is necessary normally to go back to the combination of the two premises. This is so “because in reality there is no such thing as an absolute government, where the will of the sovereign is not subject to the modifying influence of the environment, nor a democratic constitution, where the governing class does not have a relative monopoly position”. De Vito adds another qualification: “the State of type *A* does not represent a resting point or equilibrium and type *B* does not represent, in financial economy, a political equilibrium destination point”.

I would not have insisted on references to the Master’s premises if I had not highlighted here the contradictory nature of premises of this type in the “study [of] financial phenomena” rather than the limited utility of such premises. If anything, in the same treatise by De Vito, in the general theoretical part, there is an incidental reference to one of these premises with regard to the determination of the character of the institutions through which the State collects its revenue. This is the case (paragraph 31) of the explanation of the “price-tax”. In the case of a type *B* State, “where there isn’t a monopolist political group that stands to gain, taxation will be at cost price” “overall”, but the tax (that is considered public price) may become *monopoly price* in the *distribution* of the total cost among the various categories of consumers. And so the coherence of the consequences to the premise fails.

For the rest, De Viti, who had given greater importance to *intermediate* cases rather than to limit ones, by introducing an element of relativity that in part strips the same premises of suggestive and logically distinctive force, does not take them into great account. On the contrary, he neglects these premises on the basis of which he had declared the *possibility* to study financial phenomena. A possibility, this (expressed in paragraph 8), that is ignored in the development of arguments because it must have appeared not to be worthy of being logically pursued for the explanation of the financial phenomenon.

It was therefore with surprise that I read in 1949 (in *Rivista di diritto finanziario e scienza delle finanze [Financial law and science of finance review]*, March) about Einaudi’s view – which

confirms the one expressed in the preface of the 1934 edition of De Viti De Marco's *Principii [Principles]* – that, in his view, “the greatest contribution by De Viti De Marco to the progress of our science is the transfer to the field of finance of the two limit hypotheses of free competition and monopoly, which previously had been used as work instruments only in economy”.

My surprise is even greater because, in clear contrast with this critical judgment in the “*Rivista di Storia Economica*” [*Economic history review*] (March 1942), and having paid tribute to the “importance” of the two hypotheses of monopoly and competition in finance⁹⁴ the same Einaudi recognises that individual treatments are “those that sometimes” appeared to De Viti to be *according to their own objective*, “as often the link between the initial premise of the types of State and the subsequent discussions of the type of taxation and their effect was not clear”. These treatments represent the real major contribution by De Viti De Marco to the development of this science, such as to merit the definition of general, original and coherent treatise. I have myself focused on this evaluation not only to contrast opinions by the same author, but also because in these lessons I insist on the *non necessity* of such a “typological” setting regarding the subject of financial activity, to formulate and to demonstrate uniformities that regard the fundamental part of the financial phenomenon scientifically considered.

Einaudi expressed these views in reviewing the *Principii di scienza delle finanze [Principles in the science of finance]* by M. Fasiani (Turin, Giappichelli, 1941). In this work, two very similar types of States, introduced by Fasiani, correspond to the ones considered by De Viti. To be more precise: 1) type *A* State, that is to say “an organisation in which a managing elected class (dominant) exercises power in its own exclusive interest, without concern for anyone or at least for the majority”; 2) type *B* state: “an organisation in which power is exercised in the interest of all those who belong to the public group, but aiming to the particular interests of everyone or at least of the majority”.

The third type of State he considers, in addition to the ones hypothesised by De Marco (to which Fasiani's previously mentioned ones *more or less* correspond) is (*C*), that is to say: “an organisation in which the power is exercised in the interest of the public group, considered as an entity”.

Before adding my comments to Einaudi's criticism of Fasiani, I want to observe that not only I, on various occasions over the last 20 years, but also other qualified theorists have found that the original contribution of De Viti De Marco to this science was very different from the introduction of the types of State (corresponding to the limit hypotheses of monopoly and competition, in theoretical economy) to finance. This is so, if nothing else, because of the fact, admitted by the same Einaudi, that De Viti did not draw the theoretical uniformities that were expected “in the study of the financial phenomenon” from the “typological” premise on the subject of financial activity.

Furthermore, to cite two representative cases: *a*) Prof. A. Cabiati (in the “*Giornale degli Economisti*” [*Economist Journal*], November 1928), in his dedication of the bibliographical article to “Finanza di A. De Viti De Marco” [*The finance of A. De Viti De Marco*], made no reference of this aspect of the theoretical vision of the financial economy master and focused instead on its fundamental concept: that no part of the so-called gross income escapes income taxation and that every part of income arises with the burden of taxation. We will see the various developments of this premise, a premise that informs general taxation distribution concepts as hypotheses of study but that also explains to a great extent the real phenomenon. Among other things, it challenges the untenable theoretical framework that, from the time Stuart Mill expressed it until now, many have attempted to create around the presumption of “double taxation of savings” or the “defect” of direct taxation on the events of creation of new wealth, as infringements to standards or hypothesis of equality of taxation, in a sense that will be illustrated in the dedicated paragraph in the course of these lessons. At that

⁹⁴ With regard to what I will demonstrate at length and taking account of the views of Cabiati e Borgatta, which follow the current paragraph, it is not possible to surmise Einaudi's view that “De Viti used the two types of State setting almost only to *import* in the study of public and financial economy the two instruments of investigation known as the theory of price in a pure monopoly regimen and the theory of price in a competitive environment, and to give to the *whole* (my italics) treatise a clearly economic slant”. Furthermore, these statements by Einaudi are not supported by an in-depth analysis of the work of De Viti and are, in great part, contradicted by his subsequent statement, which I report in italics in the text to which the note refers.

point I will consider the logical absence of the infringement of equality, confirming an opinion no different from the one I have expressed, and demonstrating the coherence of the criterion in comparing taxes to the events of production without it being “at odds” with the logical consequence of De Viti’s premise, which Cabiati has also observed.

Furthermore we will see this opinion, that I have always supported on the basis of the analogy with Ricardo, based on an essay different from the one that Cabiati commented on in 1928, confirmed with respect to the first edition of De Viti’s *Principii [Principles]*: the setting is comprehensive (collection of taxes and expenditure) and more in-depth than other analogous previous ones on the subject of shifting of taxation, on the subject of shifting of taxation (as factual distribution, through modification of exchange relationships on the whole market, of taxation on the basis of various premises on the part of the State governing classes).

Borgatta, too, focused his attention (in the “preface” to volume IX of the “Nuova Collana di economisti italiani e stranieri” [New Italian and Foreign Economists Series]), in characterising De Viti De Marco’s work, on the “clarification of the concept of national income in relation to taxation, *independently from the premises* set in the first chapter (paragraphs 2–12, that deal with the types of State) and whose entire work is the rigorous development of the problems and fundamental institutions of finance, placing them in a logical synthesis framework such as perhaps no other in financial literature has achieved”. (Note to p. IX, with my italics.) I insist on these clarifications not only to identify previous theoretical attempts or to give insights into the history of financial theory (which would be interesting in themselves, for cultural purposes), *but to take into account the reasons and rational criteria and objectives that guide the logical presentation of fundamental questions of public finance economy in the current “course”*.

For this reason I return to De Viti’s typology, which Fasiani developed with the admirable intention of presenting an unambiguous explanation of events and uniformities, from the three points of view recalled, of State governing classes.

A) I fully agree with Einaudi’s view, who believed that it was the competence of history (and I would add politics and sociology that, at the time of G. Vico, were trying to establish themselves as legitimate sciences) to study the probable correlations between types of State, understood as Fasiani had suggested, and modes to make hypotheses about financial activity (income and expenditure)⁹⁵. This is a difficult “science”, which tries to search for uniformities over time, when to explain facts, it finds cases such as, for example, indirect taxation on consumption by considering *all three types* of State: 1) thanks to the intrinsic illusion of the inexistence of the taxation burden for the part that seems included in the economic price⁹⁶; 2) to reduce the cost of verification and collection, in addition to the psychological and political reactions, and so on.

In any case such a “science” is either not independent or it presumes that, independently from the type of State or orientation of the governing classes, financial economy has resolved the problem of the *why* of the “mode” of distribution of duties and expenditure on the part of public bodies. This is so in the sense of the analysis of intrinsic logical characteristics of such “modes” or of their rationality with regard to their economic effects or in terms of hedonistic quantities that fiscal systems or

⁹⁵ We end up not only dealing with political or sociological or historical but even psychological theory, extended to mass phenomena. A. Zorli for example had coherently so concluded in his “Teoria psicologica della finanza” [Psychological theory of finance], *Giornale degli Economisti [Economist Journal]*, May–June 1890, when he tried to correlate the qualitative and quantitative variation of taxation to the alternating selfish and altruistic feelings of the dominant classes. We get lost in the field of philosophy and metaphysics by simply trying to define concepts. Above all, however, the real phenomena systematically considered could theoretically be explained from other points of view, possibly contrasting with or different from this alternating attitude of the governing class, to explain the *same qualitative and quantitative modes* of tax collection. From this comes the *non indispensableness* of the State hypothesis as a step to observing the consequences in the logical field.

⁹⁶ See A. PUVIANI, *Teoria dell’illusione finanziaria [Theory of financial illusion]*, Palermo, 1903, which Fasiani used. According to G. B. Say, Napoleon I loved indirect taxation; indirect taxation, in spite of propaganda to the contrary, is widely used by democracies: that is so as to mislead the voting public by avoiding a formal and undeniable connection to taxation, and the consequences of that connection.

institutions determine by interfering in the equilibrium of consumers, exchange relationships, production, etc.

B) An observation that Einaudi neglected and that I, after having put it forward first, now will illustrate, is that, *there does not exist even univocally a relationship between types of State*, in the sense of the meaning assigned to them by De Viti, and then by Fasiani, Gangemi and others, on the one hand, and *market conditions* or *types of constraints of economic organisation*, where characteristic quantitative constraints, deriving from fiscal legislation or something else, need to be analysed in terms of their interference.

Leaving aside the very easy historical research of which I give some significant examples here (to confirm this non-demonstrable correlation between types of State and the *presumption*, as Fasiani names it, that “to each State limit case corresponds a particular type of economic organisation”), this author cleverly pre-empts it. This presumes that an “absolute” State (which would probably be imagined in the historical references as being characterised by a medieval type of economy) can be speculated to be an economy relying, at least in great part, on price automatism. An automatism which applies in relation to types of state varying from the “absolute” State to the “liberal or cooperative” one!

Generally speaking, in the treatment we will consider in these lessons, we leave aside such correlations between the type of State and the *modes* according to which the State and other lesser public bodies can obtain fiscal income and distribute the necessary expenditure to meet public needs. Therefore: income, expenditure, public needs that are of interest because of their shifting into expenditure, will be events and phenomena from which to draw and refer concepts, conventions, definitions, “idealisations” and “hypotheses of study” or the assumption of pure hypothesis whose substratum or historico-political genesis, that is to say the presumed trend correlation with types of orientation of governing classes in carrying out financial activity, we are not interested in.

It is necessary at this point to explain the reasons for this scientific approach. In other words, it is not a matter, remembering what was expressed in Chapter V, 2, sub A), of differentiating according to some definitions, the “real” science from the “fruitful” science, with regard to relationships with the real world or in relation to facts that are taken into consideration, or otherwise, in the hypotheses: consequently for its real ability to explain reality.

Coming back to our subject, the leaving aside of the three types of State, or other imaginable or unimaginable ones, is not dictated only by the realisation of hypotheses or the realisation that identical “modes” of being of the financial activity, including in terms of historical trends, can be found *subsequently* or even *simultaneously*, even in historical States that correspond, in terms of approach, to those *compared*, by De Viti or by Fasiani and others, to the limit.

When, however, we use the term of absence of a link to an *unnecessary* connection between hypotheses or theories concerning types of State, and hypotheses and theories and laws or uniformities found in the scientific field of finance, we refer to what in the field of *logic* is called a *contradiction*.

I have made a reference to the unease for a writer of historico-politico-social uniformities who discovers, for example, the *same* mode of collecting fiscal income, through indirect taxation of consumption or expenditure, found in *opposed* types of State.

We refer to the same fiscal institution, in the field of economic logic, that considers, *in itself*, what is rational in this “mode” of collecting fiscal income.

I) *Whether it hypothesises or otherwise one type of State or another*, the effect of indirect taxation, as an increase in the cost of *given* consumed *goods*, is that of making the tax itself *regressive* (as I will explain later), that is to say inversely proportional to the taxpayer’s income.

For example, with regard to expenditure on accommodation, it has been found (by Schwabe, as students who have completed an introductory course in statistics will know) that the proportion spent on rent of total spent monetary income, starts to decrease for the beneficiary of an income, after a certain point, as the income itself increases.

In more general terms it has been found (by Engel) that, by increasing total monetary income, the proportion of it spent on luxury goods or to meet less urgent needs increases, while the expenditure on essential needs decreases.

II) *Whether this fits or otherwise in the hypothesis of type A, B, or C State*, or another imaginable one, it can be hypothesised that, simultaneously or successively, public expenditure is affected in some way (as I demonstrated in the essay: *La determinazione della risultante del Barone e i dati del problema finanziario [The determination of Barone's results and data of the financial problem]*. “Annali dell'Università di Ferrara [Annals of Ferrara University], 1937) and benefiting in a differential way the subjects affected by an indirect, regressive tax on expenditure, neutralising or compensating for such an effect. This is from the point of view of the definitive burden on the taxpaying beneficiary of an income, in the context of *distribution* of duties and benefits on the part of the State⁹⁷.

So it is clear that the two hypotheses, pure or unaffected by history, (mode of collection of income and distribution of expenditure) can logically and simultaneously coexist in the construction of theory, whether a type of State *exists* or *otherwise*, as simultaneous hypotheses.

For the purposes of a specific reference point, open a book of elementary logic, one of those that have formed our thinking, and we will find that under the *principle of contradiction*, where it deals with the “laws of thought”, it will also say that “nothing *can* be and at the same time *not* be”. In our hypothetical thinking the type of State can be and not be at the same time as modes of distributing income and expenditure: therefore, as logical rigour requires, the hypothesis of type of State is “voided” according to this philosophical expression.

By defining a relationship as *necessary*, we express the logical criterion of non-contradiction, or of necessity of connection between various hypotheses and theories, for a complex theory such as the financial one, which we intend to construct in this case. And here we claim non-indispensableness, in contradiction of that.

This pure logic reason also leads us to reject State typology, and to adopt a scientific, rational and objective position that, as it is *incompatible*, is totally dependent on assumptions of the relationship between types of State and modes of being of the financial activity (with relative quantum), on the one hand, and assumptions of relationships between type of State and types of economic organisation or market conditions, etc., on the other.

As we will clarify later, we will analyse the rational elements of the envisaged financial events *in themselves*, as modes and criteria of distribution of income and expenditure, in the light of the points of view that will be hypothesised in the following chapters and that have already been incidentally mentioned (equality; general uniformity of taxation; its progressive proportionality; fruitfulness or instrumentality of public expenditure, etc.), and in relation to the hypothesised economic conditions on the market.

From here we will proceed, *according to the definition* given, to the start of the “course” of the science of finance in terms of economic content, to the analysis of variations of specific economic equilibriums and of general economic equilibrium, caused by the mode and *quantum* of the collection and generally obtaining revenue (for example public debt) and the distribution of the various types of expenditure in the various hypotheses of economic organisations in their various forms and of the consideration or otherwise of the “time” factor.

C) I have expressed these objections, which have been here explicitly developed for purposes of critical and systematic treatment, in the past, as I have mentioned. From the time of becoming aware of the content of Fasiani's volumes, I have been generally aware that they covered a great deal of material (especially in terms of application of Puviani's theory of illusions to De Viti's typology) that probably focused more on policy. I defined this financial policy. I have covered this conceptually in these lessons, in specific scientific terms. In the same bibliographic note (“Rivista Bancaria” [Banking Review], February 1942), compatibly with the respect due to each attempt carried out with seriousness of intent, even if not with adequate scientific results, I expressed general indirect, or rather implicit reservations, even if courteously, on the relationship between types of State and analysis of financial phenomena, in particular keeping in mind the representative and unfruitful case of De Viti

⁹⁷ Barone referred to this finance as “democratic”, but this terminology could take us back to the issue of types of State. I limited myself at the time to making it correspond to an hypothesis of mode of distribution of expenditure, which would be in contradiction with the mode of regressive taxation in order to distribute the aristocratic finance income or in the interests of those in government, from this democratic point of view.

De Marco's model, illustrated above, to which Fasiani made a direct connection. "The author makes three typical hypotheses (State models) – I wrote – that *are not an end in themselves, as it is often the case in treatises that consider them*". The concept of logical *non-indispensableness* of a link between types of State and the uniformities deduced by the analysis of the influence of financial activity or of the technical and economic characteristics of the financial institutions often found, *indifferently* and historically, in the financial policy of States tending to limit cases considered by the authors in the debate considered above was condensed in these expressions. With regard to Fasiani's *intent*, I added: "They do however become logical premises of the treatment of problems of finance, in the context of the different hypotheses". I meant this as a study *programme* or as the author's intent.

I have demonstrated in the preceding pages the sense in which I believe (in terms of political or sociological science) the correlation between the types of State and the phenomena that are the object of the study is admissible. In a great part of the fundamental problems of financial economy or in the part least discussed because of its scientific character (the economic-quantitative one) the *necessary* link between State typology and theoretical analysis is not present.

Prof. U. Ricci (*Giornale degli Economisti [Economist Journal]*, March–April 1942) highlighted this in bluntly explicit terms, *after* my bibliographical note, when he considered the "concept of *central* revenue in any form of State" in relation to the distribution of the cost of public services. In particular he observed: "One could be surprised to see the shifting examined separately from the three States, *A, B* and *C*. Perhaps the laws or uniformities of monopoly and of competition, of elastic demand, are different in one or the other? Do Cournot point and the trend upwards of a cost curve vary in one or other of the forms of State?" He made other observations along these lines.

Neither does Einaudi (*Rivista di Storia Economica [Economic History Review]*, March 1942), even after the already mentioned bibliographical note with my implicit reservations with regard to the three party model put forward by Fasiani, as I have already reported, find the correlation between the types of State necessary and, for example, uniformity such as the one regarding the concept of general taxation. (I refer students to the source for brevity.)

I have followed my already mentioned critical position of the quoted authors in 1942 with a *constructive* position in the sense of replacement in the methodological and logical field, that is to say in the terms suggested in the previous letter *B*) of this paragraph, on previous occasions, both in teaching and scientific terms. More precisely:

a) In the previous edition of these lessons, by accepting in the sense of Paretian logic mentioned in Chapter VIII – *d*) *a* and widely illustrated here, as the task of the science of finance to study the numerous *specific constraints* that influence the solution of problems of individual and collective equilibrium, on the market, in function precisely of the interference represented by the various types, for example, of fiscal revenues that the States collect, regardless of the *type of State* in history these "constraints" refer to.

These concepts have been developed analytically in the two preceding paragraphs where the *autonomy* of the science of finance from political economics, as pure, general economic theory is demonstrated, and some warnings are expressed on the limits of this autonomy, which is intended as a degree of specialisation.

b) Another point of view from which the treatment of the financial theory *detaches itself* from the types of State regards the hypotheses of *market or organisational conditions in the economic environment* in which fiscal constraints have an impact, *independently* from the type of States hypothesised by De Viti, Fasiani, Gangemi and other authors in the past, and in any case conceivable from the points of view of classifications by such authors. These are hypothetical conditions of the economic organisation or environment to which specific fiscal constraints will systematically, by degree of abstraction, refer to.

In this sense the logical and historical correlation between some hypothetical economic conditions and type of State seen from a case limit or by a mixture of limit hypotheses is denied. The same hypotheses of economic organisation, with differences in terms of degree, can occur, irrespectively in the three types of State.

Therefore the theoretical uniformities that will be treated and discussed also in the light of research in the science by numerous academics will have an interpretative value or function for events

of political orders of *every time*, of orientation of the governing classes of *every* imaginable type, of *any* imaginable *market* in space. In this sense the treatment of public finance economy claims to be rational and objectively suitable for providing explanations of generally all the typical events of financial activity: to be therefore a “universal” science.

I made a brief but explicit reference to this idea, even if only incidentally, in the treatment of a financial theory (preferability, from the subjective point of view or the point of view of the sacrificed utilities, of the loan of extraordinary taxation in the essay: E. D'ALBERGO, *Prestiti e imposte nelle nuove teorie e nella esperienza bellica [Loans and taxation in the new theories and in military experience]*, published in “Studi dell'Istituto di scienze economiche e statistiche” [Studies of the Institute of economic and statistical sciences] of Milan University, 1945).

In fact, I had formerly established a logical *necessary* connection of the theoretical uniformities in the field of public finance to the typical hypotheses of: α) economy with minimal constraints or “free” from State interference; β) economy with maximum constraints or totally controlled; γ) partially “regulated” economy or economy subject to intermittent interventions that are not indicative of an integral and organic collective organisation.

Therefore (if anything, with regard to this classification of finance, as systematic theory qualified by less-than-useful adjectives), we must deal the quantitative problems that form the object of the main undisputed part of this scientific discussion.

With this vision, which completes the study of rationality of the typical “modes” of income and expenditure and of “fiscal constraints” generally, public finance economy becomes a theory, as I have said already, that can explain the historical events of yesterday, those of today and the virtual, probable and future ones that, with respect to those institutional aspects of society considered over time, can be summed up in the basic hypotheses of letters α), β) and γ) of this paragraph. It is no longer necessary to check if the market conditions here indicated correspond to the types of State characterised in the deliberate or “unintentional” attitudes of the governing class.

However, *regardless* of the type of State, or the “concept” of the financial phenomenon, the *uniformities* (deduced among other things by acknowledging the various hypothetical measures of the financial activity or types of *specified constraints* and, at the same time, the various organisations of the market or diverse, variously constrained, regulated and controlled economies) will be valid in the *context of such hypotheses*. Furthermore, as the conditions of the market, more or less free or regulated, will be abstractly and in terms of corresponding historical situation confirmed as being recurrent, in totality or in part, in the different types of States, the theory will explain in total or in part the facts that refer to types of State, differentiated by other authors judging only the attitudes of the governing classes in distributing costs and benefits of public services.

My concept exceeds the logical cohesion requirements established by linking theoretical uniformities to types of State. And this is not only because the necessary and unequivocal relationship between type of State and type of organisations and market conditions of this latter one has been methodologically devalued by its supporters. I am aware of the difficulty in classifying economic orders or more or less approximate or distant conditions with regard to the one that is used to define “market economy”, generally characterised by minimal constraints. I share, from this point of view, Vinci's scientific scruples (*Gli ordinamenti economici [Economic orders]*, Milan, Giuffrè, 1945) when faced with the task of broadly classifying economic systems. He thus criticised *succinct* judgments of this nature, given the multiplicity of criteria that a particular eclectic order, where there is no clearly defined predominant approach, must meet. He did so after expressing the idea of: *a*) predominantly free market orders; *b*) predominantly collectivistic orders; *c*) orders that do not show any predominance. (The italics are mine: for these reasons I *analytically* refer to “conditions” and constraints of economic organisations.)

More recently, referring to *individualism* and *collectivism*, as currents of ideas relating to the relationships of the individual with the State, Vinci stated: “even though they have not been realised (we recall, among others, the negative experiences of the second half of the 19th century in the United Kingdom and in the 1917–35 period in the Soviet Union) and they are demonstrated to be unattainable; they include an innumerable range of economic orders: they are eclectic orders, whose directives and elementary criteria derived from one or other current of ideas that it is not difficult,

generally, to understand" (F. VINCI, *Breve introduzione all'economica [Brief introduction to economics]*, Zuffi (Editor), Bologna, 1949). Vinci returned to these admonitions in *Istituzioni di economia [Economic institutions]*, Bologna, 1950.

These are basic orders in spite of the *coexistence* of *heterogeneous criteria* (State monopoly in some branches of production with collectivistic criteria, and private initiative in others); or also *criteria contradicting* each other (imposition of price controls, that is to say lower than that corresponding to balance between demand and supply – collectivistic criterion – and maintenance of private production and negotiation of goods or services). I will take all this into account in addressing the theoretical problems of this "course".

Prof. Varga, of the University of Budapest (in the journal "Economia internazionale" [International economy], November 1949) also wrote of this eclecticism, illustrating the evolution of the Soviet economy, which instinctively comes to mind [as was noted in 1949 in Bresciani Turrone's course or in Vinci's "Istituzioni" [Institutions] of 1950] every time we make reference to collectivistic hypothesis of economic order in our discussions.

Before reporting, concisely, significant omissions by this author, I want to remember that large scale monetary reforms and State interventions were officially justified in these years, in Russia, in part with the purpose of accessing the profits, obtained on the "black market" "to the detriment of consumers", of some groups of "speculators". This demonstrates the functionality, within certain limits and – which is relevant for the theory – *generally* in a market without constraints, of the hypothetical type of "liberal" or "free market" and eclectic economy. This is also historical proof of a mode of *differential* taxation of "relative" contributory capacity, a concept to which I will return in the relevant chapter. All this is representative of the *coexistence*: 1) of a *type of State* corresponding to the limit case of nationalistic type, according to some, or monopolistic type according to others, in terms of behaviour of the governing class; and 2) (with apparent contradiction) of market *conditions* observable in other types of State (for example, democratic and cooperative). So that, with regard to financial theory, it is again proven that it needs to be free of correlation involving State models and refers to types of market *conditions*. These can be more or less constrained, regulated or controlled to assume, as a science, universal values or to be valid for each sector of space and for every time.

Going back to Prof. Varga, after the premise that modern theory does not accept the traditional opposition or antithesis between capitalist (bourgeois) and socialist political economy, he states that "private property and contract freedom never exist without limitations and in any case they exist in whatever rudimentary forms even in socialist regimes". In the particular case of the Russian economy, Varga accepts (as our Barone and Pareto, among others, had already demonstrated in terms of pure theory) that generally: I) production phenomena are necessarily similar in character; II) utility points of view have a directive function for Soviet companies as well, because they are the only ones that can be used as a starting point for effective management control; III) even competition is not entirely eliminated in the Soviet economy; IV) the phenomenon of ground rent takes place also in the Soviet economy and the State intends it to be absorbed for the benefit of the community; V) even though the interest rate is fixed unilaterally by the State, similar considerations in terms of market valuation apply as conversely, in capitalist countries, market-independent considerations play an active part in the setting of interest rates.

I will not continue with these and other quotations from which we can deduce that, having identified *types* of economic conditions or organisations or economic orders that are too artificial, as *sets* of institutions relating to the economic activity of a population (Vinci), corresponding in broad lines to the definitions in letters α), β) and γ) of my 1945 essay, it is not possible to imagine that we have reached clear and unequivocal differentiations. It is not possible therefore to imagine a classification of markets as *variably (an issue of degree) constrained*, with *analytical* reference to the "conditions" already mentioned.

For these reasons I will *not* qualify the scientific uniformities characterised by the intervention of the fiscal or financial constraint as pertinent to the "finance" artificially attributed to free market, collectivistic or eclectic orders. If anything, the financial theory that reflects the limit hypotheses α), β) and γ) of the (market) economy without constraints, totally or partially constrained or regulated or

controlled, is accepted by those who have a compelling need to classify theories when this differentiation in *first approximation*⁹⁸ is accepted.

It will be however more correct to discuss the public finance economy as a system of theories or a set of uniformities relating to:

I) *the rationality or "modes" of fiscal institutions and facts; qualitative "modes" or characteristics of the means used by financial activity, that can logically and historically coexist in the three types – and other possible ones – of State and therefore independent and not necessarily linked to a typological hypothesis, such as private and public prices, taxation, contributions, general and specific taxes, etc.;*

II) *the effects of financial activity (collection of revenues, distribution of expenses, deployment of resources for fiscal purposes, etc.) in the hypotheses that reflect conditions in the activity of the members of the community or bodies acting on their behalf. These hypotheses can be very varied and can be identified in the most diverse and sometimes antithetical types of State (in the sense of those in A, B and C), or in economic orders of the possible diverse human societies.*

So: theoretical uniformities can be formulated by creating an hypothetical link between financial facts and: *a) institutional conditions (private and public property, hybrid companies, cooperatives, etc.); b) the conditions of the offer (State enterprises, nationalised companies, monopolies, cases of perfect or imperfect competition, bilateral monopoly, duopoly, hypotheses of increasing, decreasing and constant costs); c) degrees of freedom and elasticity of demand, of "choices" and of consumption (complementarity and substitution of goods and, generally, goods substitution relationships, rationing, bans and other limitations, hypothesising constancy and variability in the marginal utility of money and relative "consumer revenues"); d) interventions in the field of investments (reduction of arable land and compulsory distribution of agricultural crops, authorisations for new industrial plant, money management, authorisations for forms of financing, etc.); e) the contractual freedom implicit in work relationships, the involvement of associations or trade unions in fixing minimum wage levels or the imposition of a quantum of unemployment of the workforce; f) the free circulation of goods in the closed market and the free setting of relative prices or price control policy, of privileges for consumer companies, public companies, limitations and licences in the field of international movement (open markets) of goods, etc.; g) the gradualness or the absence of constraints relating to incomes, profits, interests in the various hypotheses, etc.*

These and other typical cases of economic constraints can be identified respectively, not necessarily in only one type of State, but they are to a certain extent also independent of them because, as I have said before, they can *coexist* in the same type of State. It does not matter to what extent (degree); for logic and financial economy it is sufficient to express the type of hypothesis, irrespective of the degree of probability or the frequency with which the real phenomenon corresponds to the same hypotheses, in different institutional orders.

Referring to the first (*a*) and, in particular to the second part (*b*) of the definition of the science of finance, and the arguments in this and in previous paragraphs, I think we can identify the scientific theoretical vision of public finance economy. This appears to be the most rational, objective, neutral and abundantly comprehensive, that is to say universal vision, and therefore suited to explaining the facts of any institutional environment, of any type of State. This is so because the

⁹⁸ However, this too artificial "first approximation" can be contradicted by facts in such an immediate and undeniable way that it is pointless to express it, just as I demonstrate in the case of the totally controlled economy, or the collectivistic system, as others define it. As I reported earlier, there has been an historically proven reason, to a significant extent, with general importance of measures such as "the exchange of money", for the *coexistence*, not at all marginal in the collectivistic system, of sectors of the economy regulated by those laws that are dominant in the hypothesis of lack of or minimal market economy constraints.

Here is a snippet of news that can shed some light on this issue. Swiss sources report that, as a consequence of the Korean war and its feared international repercussions, in the space of a few days there has been an increase of 80% in the Russian "free market" for flour, bread and potatoes. This is a far superior sensitivity to what the news reports suggest for other markets in the so-called capitalistic world, that is to say politically and economically ordered according to constitutional models that are very different to those in the collectivistic world, in relation to the same causal factor.

uniformities or theoretical laws are derived from the consideration of fiscal constraints presumed to operate on the distinct hypotheses of market conditions and the characteristics of the financial “modes” or orders that are imaginable in abstract and to which historical situations from the past (and the present and the virtual or simply probable in the future) generally correspond.

The “detachment” of passions, feelings and interests, according to the most rigorous scientific methodology, is ensured by this position with regard to the requirement of a theory of public finance economy, in a better than that attempted by others. Furthermore, Fasiani often lacks the cold neutrality of the scientific observer precisely when unwittingly and unintentionally he expresses *value judgments* as in, for example: *a)* he defines the “nationalistic State”, the type of organisation towards which we tend to move in our times, as “modern, the ultimate and most vivid expression of European civility”; *b)* he considers the liberal State and the absolute State as deviations from the trend towards the nationalistic State that “represents the last stage of historical evolution of political organisation”; *c)* he considers, thinking of a near future, uniformities relating to political organisations, such as those corresponding to the parliamentary democratic State, to have historical character as they might be of interest “as a pure theory of tyrannical economy might be of interest”; *d)* he does so in spite of the fact that, in countries “that are commonly defined democratic”, some approaches “indicate a tendency of the economic and financial organisation of those States to approach unconsciously and illogically the type of nationalistic organisation purposefully and coherently pursued in Fascist Italy, in spite of the denial of foreign executives”.

These quotes from Fasiani’s *Principii [Principles]* suggest uncertainty and, as it is clear in part, the caducity of historical and political value judgment which is derived from wanting to adopt and continue with the typology introduced but immediately abandoned by De Viti, after a first unfortunate and not very fruitful analogical vision. These are generally historico-political judgments that are alien to the scientific rigour elsewhere amply demonstrated by Fasiani, in the separate treatment of economic nature.

I have persisted with these models, as I could have done with other “settings” or “concepts” of the financial phenomenon, so easily demonstrating their limited ability to explain the logic of transferring, overall, a quantity of purchasing power (mass phenomenon) in the field of needs and expenditure of pertinence to individuals acting on their own initiative, to the sector reserved to the activity of the State in meeting needs which are therefore defined as public; however, not even the specific “modes” of being of the institutions that the State can use to distribute the cost of public services at any place and time, in the individualistic sense specified above, benefit from flashes of lightning that clarify some aspects of such “concepts” or “settings”. I believe De Viti’s significant attempt,(followed by Fasiani’s, with regard to the introduction of the types of subjects of financial activity or the State governing classes, at length analysed here as the explicative instrument of actual trends), to be unsatisfactory, in particular because of its logical contradiction with regard to the very same phenomena.

We must emphasise the use of the term contradictory, not only referring in the philosophical sense to elements or parts of the reasoning, as we have already seen, demonstrating the logical non-necessity of the relationship between hypotheses of types of State and uniformities or theoretical laws in the financial field.

Furthermore, in identifying contradictions between “models”, “approaches” and facts and phenomena, we do not intend to deny the reality of the hypotheses, in the sense we have already discussed.

In fact there have been frequent occasions, in the preceding chapters, to highlight:

a) the logical legitimacy of the hypotheses, even if they do not reflect actual facts, but future or probable events and circumstances;

b) divergence of the hypotheses from the facts, even if in the past, in the sense that the basis on which they have been constructed reflects and explains aspects and idealisations of the real, that cannot be theoretically analysed in all the complexity of the real, but through simplifications of the same facts;

c) relevance of facts, considered typical even if not necessarily more “frequent” in the historical statistical meaning of the term;

d) α) *harmony between theory and experience*; β) *links with reality*; γ) *concordance of reality with the hypotheses, in the sense of the meaning in letter b*).

But in cases a) – d) it was not *the intention to discuss contradiction between hypotheses and facts*.

This term, in addition to the already mentioned logical meaning, is used here to indicate the logical non compatibility between the models under analysis and the facts. This is to indicate the cases where hypotheses contrast the tendency of being or in the sense of the unfolding of events, even if they are simplified, and “unreal” for this reason alone.

On the other hand, presuming that modes of being of duties or of the “environmental” conditions in which they operate are not compatible with the hypothesis of a given type of state is furthermore in contrast with facts when reality presents the coexistence, amply demonstrated earlier, of modes of distribution of the cost of public services and distribution of expense on the one hand, and constraints or market conditions that can be found, in the same form and with the same characteristics, in all types of State on the other.

Such contradictions, even if admitting, as in these lessons, the widest domain of hypotheses, cannot be admitted in a science that has as its object the explanation, be it even indirect or partial, of facts and phenomena analysed in simplification or hypothetical idealisations, stretched to the limit of abstraction; never however in the sense contrary to the normal manifestation of facts and phenomena, or even exceptions or marginal manifestations of them, without limitations of time and space⁹⁹.

Furthermore, it would be easy to critically review these so-called “conceptions” to demonstrate: 1) the absence of explicative ability [of any part of the financial phenomenon] of these “models”, once stripped of the terms “concepts” or “settings”, which are often conceptually imprecise; 2) the partiality of the explicative approach of these models. These are often feeble

⁹⁹ L. Gangemi, who, however, generally sensed the importance, in my view decisive and uniquely relevant, of the type of economic structure for pure financial theory, an economic structure characterised by the gradualness of the constraints represented by the various types of legislations, was not able to break free from the reference to types of State in the sense of their politico-social constitution. Such reference is *not necessary* and, as I have demonstrated in these pages, often inevitably contradictory. He places side by side the typology introduced by De Viti and continued by Fasiani, the model of a constrained economy State and quoted as an example the *cooperative* State and the *collectivistic* State model, whose historical realisation he identified in the Russian State capitalism. *Elementi di scienza delle finanze [Elements of the science of finance]*, Jovene, Naples, 1948, in which he refers to previous expressions of his thinking. In particular see the “Warning” and Part I.

In my view, it does not matter, for economic theory, if the economy is constrained by “*a totalitarian regime*” or by “*democratic governments*”. We are not interested whether it is “*fascist corporativism*”, “*national socialism*” or “*falangism*”, with the associated “*concerns*” of the governing “*elected class*” or with relative social and political visions of the interest of the individuals or of the community. Political and social *regimes* are not relevant to the relative coordination of the interests of individuals with those of the group or of the majority. Nor is the fact that the nation is viewed as a whole or otherwise, or that the “*political behaviour and its consequent economic behaviour*” are “*based on concepts of the State as an idea, a category but first of all a reality*”.

It would be that experts of “*political science*”, of economic history, of sociology and “*of political journalism or philosophy of law*”, can deal with the historical correlations (if they exist) between government’s classes (with diverse political ideologies) and organisations or conditions of economic life, as the same Gangemi conveniently notes for these disciplines, even though he does not take account of them.

The fact that some types of economic organisations are inclined to reach the *objectives* of the social modern State, with relative trends towards realisation of social goals with economic content is not, in our case, a matter pertinent to financial theory. This theory hypothesises, regardless of political organisation, *abstract conditions* of economic relationships the most variously constrained, that determine the solution of quantitative problems when the specification of fiscal constraints is introduced, whatever the *presumed* politico-social State. All the more so that, as I have repeatedly stated, the most diverse hypotheses of economic conditions in which the taxpayers’ activity takes place can be *simultaneously* conceived, *without any fear of historical retraction*, as all the hypotheses can in fact actually occur instantly, in all types of State or of organisations or of political regimes that De Viti, Fasiani, Gangemi or others might presume, without financial theory being in any way affected by this. This also applies to the *modes* of obtaining revenue and expenses that might technically be found in all types of imaginable political organisations and historically tending towards them.

laboratory exercises that concern those starting to work in the field of the science of finance, perhaps without rationally determining a specific approach or aiming to solve any specific problem, in the hope of being able to offer an “original” tool, able to illustrate and explain coherently and permanently *all* observable facts of the financial activity.

As *limit cases*, we can think of:

a) The concept that has the intent to explain the *quantum* of purchasing power deducted from the hedonist State and faced with needs to be met, compatibility with maximum ophelimity or subjective utility, extending to the consumption of public services uniformities of pure theory of economy (equality between weighted marginal ophelimities). That intent of “concept” (for these services) does not hold in a field where coercion to consume public services is dominant and where the hedonist mainly faces unknown costs for these services rather than prices that are known in advance. As we will see better later, that intent of “concept” might perhaps be better applied to explain *directly*, among the “modes” of obtaining revenues, private, quasi-private and public prices and taxes, that is to say the institutions characterised by a voluntary element or freedom of “choice”;

b) Alternatively let's consider simply paraphrasing the definition of a *part* of the financial activity, i.e. the “concept”, through which we ingenuously find that the same State activity is characterised by *coercion*, strangely differentiated into formal and real. As coercion, given the prevalent *definition* of public needs, this cannot but clearly concern, both the compulsion of using a service and the obligation to integrate, pro-rata, the cost of the same service. And even admitting that this sheds light on more than a definition, it can be noted that this also excludes the problems relating to “modes” of obtaining revenue *without coercion* with regard to both means (the institutions indicated in the previous letter *a*)) and the various forms of voluntary public loans involved in voluntary and compulsory *consumption* in terms of public or instrumentally equivalent services.

A hurried and formalist bibliophile, faced with consecutive editions of my lessons, could believe that these arguments contrast with the presentation of the “main theories aiming to explain the financial phenomenon” in the lessons of 1944 (Chapter II).

An intelligent and competent reading of that chapter would however prove that, in the logical spirit that characterises my critical and reasoned presentation of the subject, I have in fact used some of the most frequently repeated and celebrated theories and hypotheses to confront them with institutions, systems and facts, as a logical test bench. I have done so as to test their strength and their explicative reach, that is to say to verify their concordance to or divergence from the phenomena to which they have been applied, with degrees of abstraction.

[I must warn you that I have a propensity for the use of the concept of “theories” and “hypotheses” in a not dissimilar manner, as many eminent experts of the methodology will admit, from that used in classifying the gnoseological instruments used by this science. In any case, hypothetical theories are discussed in scientific treatises while we talk about hypotheses and theories as links between ideas and facts. Hypotheses sometimes acquire the definition of theories, when we move from a concise form (hypothesis) to a wider one (theory) to link what we know. Some methodologists define theories as hypotheses “complicated” by the gradual differentiation of the same gnoseological order].

In particular, in the previous course of the science of finance “for students”, I have referred to both theories and hypotheses to explain financial facts to the limit of their gnoseological purpose or explicative logic, or to examine the rationality of the “modes” to obtain fiscal revenue and the effects of the collection and expenditure, at the same time, on the economic relationships of quantities in equilibrium.

This explicative intent of institutions, systems, “choices” of the subject of financial activity in the 1944 edition of these lessons (already mentioned Chapter II), in light of the theories or hypotheses, was to such an extent developed or logically applied that, when I came to cover public revenues in Chapter VI, for example their classification and differentiation, I did not think it necessary to insist too much on the logic of revenue categories, presented successively and in rational comparison, considering the explanation already generally given of them (in the partial light of the economic theories and hypotheses examined in chapter II). Indeed rarely the presumptions of “concepts” and “settings” (as we have seen for the concise references in letters *a*) and *b*) immediately

preceding – when they are really fruitful and valid, and not petitions of principle and reformulations of definitions or “conventions”) are deemed appropriate to illustrate *all* the phenomenon, and often clarify parts of them that are sometimes important.

Even formally, in the order of the subject in these lessons, the subjective hypotheses or theories or concepts or settings will arise *indirectly*, only if they can appropriately explain institutions and modes of being of revenues and expenditure and in the problems that arise in the distribution of the cost of public services, or to explain the pressure of State coercion, the recourse to public lending with relative pressure on the market in terms of cost of the redistribution of investments and of the subjective utility sacrificed by taxpayers, etc.

As students and readers might be curious, however, to know the subjective “concepts”, the “schools” and “settings” of the experts of financial reality, for a concise presentation of many of these and for carefully updated bibliographical references, especially with regard to Italian literature, I refer you to the text and in particular to the bibliography in: L. GANGEMI: *Elementi di scienza delle finanze [Elements of the science of finance]*, Naples, Jovene, 1948, and suggest you go back to *Lineamenti di letteratura finanziaria [Characteristics of financial literature]*, 1929, by the same author.

Always for the purpose of knowledge of the history of theories, that is to say for cultural purposes, and not because they might lead to modified analyses and rational conclusions in this “course”, I also refer you to, among other things, the various quotes and the bibliographical summaries in the apparently monographic work of E. R. A. Seligman – *La traslazione e l'incidenza delle imposte [Taxation shifting and incidence]*, first Italian shifting of the second edition (1898) contained in Series V, Vol. XVI of the Biblioteca dell'Economista [Economists Library]. I also suggest reading *Storia delle dottrine finanziarie [History of financial doctrines]* by G. Ricca Salerno, 2nd edition, Palermo, Reber, 1896.

CHAPTER I

PUBLIC NEEDS – PUBLIC EXPENDITURES

I.

PUBLIC NEEDS

As has already been mentioned, these lessons are aimed at students and experts in economic sciences, that is to say, those who have attended or read about and analysed courses of political economy.

This is important with regard to what is covered in this chapter. In fact it will be read by those who have noticed how very little space has been given to the category of *needs* in the main economic treatises. Indeed they pertain to the scientific specialisation of *psychology*.

Whoever has also studied, for example, the *Principii di Economica [Principles of economics]* by Marshall will remember how the great fixer, having paid tribute to the research into the formal classification of needs, thought it was “unnecessary for our purposes”.

Referring to the analyses of needs and desires found “in the great majority of French or continental economy treatises”, Marshall stated that “the rigid boundaries that English academics have assigned to their science have precluded such discussions taking place”.

And we cannot forget the approach of the “continental” expert of political economy, according to the general model of economic equilibrium, Pareto, who could be said to have incidentally dealt with needs, in his *Manuale [Manual]* (Chapter IV). This is mainly to clarify, in relation to *pleasures* (pleasure felt by people in consuming or using some things), that: α) while the equivalence relation (between consumptions corresponding to a specific need), referred to the “pleasures” of the individual is nothing other than the relationship given by the indifference “curve”; in case (β), in which the equivalence is referred to as “needs”, there is no difference between the equivalence relation and that of the indifference curve. I think this is the main reference with regard to the concept of need.

Such representative positions cannot be neglected and are still current. Open the *Corso di economia politica [Political economy course]* by Prof. Bresciani Turrone. I mention it because he reasons in the logical context of Marshallian and Paretian models, and because his treatment is one of the most recent (as I have mentioned before, in 1949). He warns us that a chapter on “needs” should always be included in a treatise of economic science, “whatever the politico-social regime, and it should be the natural introduction to the scientific analysis of economic facts”. Although, he hastens to add, “It is not, however, the task of political economy to look in detail at the notion of need”. And later: “Whatever is the source of needs, it is sufficient for us to ascertain that at a given time the individual feels different needs, to which he does not attribute the same importance”; he then goes on to criticise the rough attempt to classify needs according to their “absolute” importance, with “vague and uncertain” results.

The same can be said for the two orders of thought that brought Bresciani Turrone to mind: of F. Vinci [op. cit.], whose 1950s essay indicates the relevance of this concept. In this text he barely mentions “needs of various nature” at the start of the treatise. He takes them indirectly into account by assuming that the subject (who is defined, similarly to L. Amoroso, as a consuming unit) attributes to the overall quantity of goods and services consumed in a given unit of time a satisfaction index derived from an arbitrary scale. So the notion of need, barely acknowledged, disappears.

This notion is a factor in the presentations of these authors, who have a similar position to that of Amoroso, who is considered one of the most reputable supporters of the theory of economic equilibrium.

There is no reason, in a treatise of public finance economy, to assume a different position from that which represents the needs of the community with regard to the activity of the subject (State or lesser public body) that, to satisfy them, collects revenue and deploys expenditure.

De Viti De Marco, in specifying the “*Carattere teorico dell'economia finanziaria*” [*Theoretical character of the financial economy*] (1886), admitted: 1) that “as it is not necessary for the economist to discuss which needs man must satisfy and which he must not, so it is not necessary for the purposes of financial investigation to discuss the needs of the State, that is to say, its duties and the expenses it must meet. Expenditure is a prerequisite because in fact a financial activity event arises in order to meet any expenditure – that is to say for the achievement of any objective”; 2) that “the diversity of public functions according to the various periods and countries, *is a fact* and it is a also a fact that a financial activity on the part of the State in any case takes place”. But even assuming this, he adds (in *Principii di economia finanziaria* [*Principles of financial economy*], op. cit. p. 19); 3) “It is one thing to recognise that the field of public goods is a given of financial activity, and something else to analyse and explain the same fact, to study the law of its being and its becoming”.

Moreover, an analysis of the *objective* content of what are normally considered public needs has proven to be of limited explicative effect and not necessary. We can start from the assumption of the existence of various needs to be met, correlated to the aims or functions of the public body and, therefore, with the expenditure it sustains. Public needs are therefore *given facts* in our argument. It is sufficient to remember that *public needs* are those that are *met* at every historical point by the *public body*, by meeting expenditure with public revenue. Thus I concluded in previous editions.

This definition may appear to be, as some have observed, a pure “petition of principle”. However, attempts to analyse the *objective* content of the notion of public needs, carried out by economists and experts of sociological and political science, cannot be considered to be satisfactory. Therefore it is the case that, with no implicit interest in themselves other than that which they have taken as facts, we can identify them with reference to the *subject* of the financial activity, as it has been outlined in the definition of the science of finance or public finance economy that homogeneously shapes these lessons.

Indeed the “historicistic” element dominates this subject and overwhelms attempts of economic logic to qualify public needs in terms of their nature and their content. They are the most diverse and varied, in time and space, as the same needs can be met, alternatively and successively, by private individuals and their organisations – that some expert, in the role of sociologist, has seen fit to define as “private groups” – and public organisations essentially such as: State, regions, provinces, departments, municipalities and other territorial and institutional public law bodies, to whom the law assigns the function to meet the needs and requirements of their corresponding communities, that is to say, the authorisation to meet expenses and the power to collect the necessary revenues.

In the previous edition of these lessons I have talked widely about public needs, giving references of theory development mainly of an *historical* nature and in homage to the authority of our first experts, who had attempted to find a basis for classifying private and public (or collective, according to some) needs to demonstrate how they only partially explain some of the aspects involved in real public bodies meeting such needs. Or to demonstrate (in the recent and recapitulatory case of Paolo Ricca Salerno) how the proof of this logic contradiction can be found in the same monograph aiming to classify needs to be met on the basis of their *nature*. This is so because this notion, linked as it is to events and variable historical and political contingencies, resists attempts to be logically solved in part because of the different approaches of organisations in old and modern societies and the different extensions of the financial activity of public bodies. Therefore these hypotheses, when they are not in themselves contradictory, lack the ability to offer any explanation.

If it is really necessary to persist in understanding the sense in which an attempt has been made to find an objective content for public needs, it can be said that these attempts have revolved, especially at the end of the 19th century and the start of the 20th, mainly around these four positions:

a) application of the financial phenomenon of the principle of *minimum means*, that is to say, of the satisfaction on the part of public bodies of the needs that they can meet with a lower cost or at the same cost but with greater satisfaction for the community. Supporters of this differentiation criterion include: Berardi, Mazzola, Cossa, as mentioned below, De Viti De Marco, and in a certain way also Einaudi, Graziani and others;

b) application of the concept of *hedonistic maxima* to the financial phenomenon. In this vision (mainly illustrated by Pantaleoni and Bertolini) “public” needs are those that are by necessity met by

public bodies. This is so because, in meeting them, only the maximum collective hedonism (and not *also* the individual one) can be reached, as some people must be *compelled* to make sacrifices for the good of the overall community. This coercion can be imposed by the public body. From a certain point of view it might be possible to include De Viti De Marco in group *a*), as the division of tasks carried out by the private and public organisations presumes a more efficient supply of public services. It could be classified in group *b*) because of the premise of “conflict of interests” as a characteristic of “collective” needs, a conflict that requires the intervention of the State and that persuades De Viti to consider the collective need, represented by the *algebraic sum* of positive (production of public services) and negative (non-production of public services) needs: this is similar to Barone, who believes that “public” needs are those met by the public body, compelling others to make sacrifices for the greater good;

c) application of the financial phenomenon to the concept of *monopoly*, in the sense that, without intervention by the State, some needs could be met by private organisations or by private individuals in a regime of monopoly, with prices for the individual beneficiaries of the service that are higher than the reimbursement of production costs. This is a recurring criterion with many authors;

d) application of psychological and technical notions, in the sense that: I) private needs are felt and perceived by individuals and public ones are not felt or perceived by individual components of the community but are interpreted and evaluated by collective organs, independently from individual perceptions; II) they are indistinct and inseparable, with relative difficulty in assigning sacrifices, advantages, requirements and satisfaction to individuals.

These concepts, that give rise to contradictions in terminology and with the history of financial events, also appear in many economists' studies.

It is not necessary to recall real historical cases, over time, of needs met by public bodies, such as military defence against external enemies, the internal maintenance of public order, the administration of justice, education, the common viability of trains and planes, health service, welfare, etc., to understand how the attempts logically indicated in *a*), *b*) and *c*) cannot explain but moments or aspects of the financial phenomenon. Indeed the contradiction in the facts that they intend to explain largely weakens hypothetical visions, making the relative or partial theory inappropriate in explaining the real phenomenon, even though the logical legitimacy of some of the hypotheses remains. As typical cases of the historical phenomenal reality, drawing from common culture, consider how the same State defence was left to companies of adventurers as well as directly to the public body; how the maintenance of internal order in some States and even in our own municipalities (night or rural watch, etc.) is carried out by private bodies; think of the administration of justice by means of arbitration associations; of transport services, at the same time or alternatively entrusted to private companies or public administrations; of education provided as a service by private and public organisations; of assistance provided simultaneously through public and private initiatives; of nationalisations, *or otherwise*, of banks, industries, etc., as economic and political circumstances change: the “re-privatisation” of German banks after State intervention is symptomatic of this, and so on.

Having said this, I leave it to students and readers to easily deduce:

I) numerous cases of public services produced and offered by a public body at a cost higher than it would have been to have those same needs satisfied by private initiatives. The intervention of reasons (that we will define as political for brevity) can, historically, lead to the supply of services whose management is often in contrast with the premise of *minimal cost*, to satisfy what political conditioning assumes to be public needs.

II) the cases in which there is not necessarily any “conflict of interests” and the choice or demand for services offered by the public body, which meets the expenses and collects revenues, are free compatibly with the undertaking of these services by the public body.

III) cases where the undertaking of the task to meet public needs is not necessarily dictated by convenience or the opportunity to avoid, in the absence of public initiative, a market condition of monopoly in the supply of services and goods on the part of private producers, on equal terms for the needs of members of the community or groups of them.

IV) the judgment of the theory that presumes public needs are not “felt” by individual members of the community, as they are in fact the ones able to express feelings that are “interpreted” by the governing class.

An *explanation* of the arising of needs defined as public simply because they are met by a public body (or public group) is *irrelevant to public finance economy*. I am referring to attempts of *sociological* character simply because economists have become involved in this construction whose only merit is the renouncing a definition of public needs linked to their objective content and referring to needs that have been *historically* satisfied by public bodies or groups, thinking “a posteriori” with the purpose of identifying the dominant characteristics of the historical trend.

With regard to this, I will recall again A. Puviani’s theory of financial illusions. Generally speaking, explanations of public needs as a function of the interest of the governing classes in declaring – or otherwise – such needs as public needs belong to *politico-sociological* theories. For brevity here and for bibliographical references, I will refer you to the works of R. A. Murray (*Le nozioni di Stato, dei bisogni pubblici e dell’attività finanziaria [Notion of State, public needs and financial activity]*, Rome, Athenaeum, 1913, and his already quoted *Principii [Principles]*) as well as those by Fasiani (already quoted).

I must also mention an essay (included in the *Nuova Collana di Economisti [New Economists Series]*, Vol. IX, Finanza) by R. A. Seligman that I translated. In this, the well-known economist indicates that sociologists have not been able to respond very well to the question that he had asked, among others: “Which notions of sociological theory can be applied in economic science or to finance?”.

In the said study of finance from a “sociological” point of view, which is of no interest here other than as an “indication” (in the methodological sense mentioned in the *Introduction*), the author differentiates public needs, as the needs satisfied by the “public group”, from private ones on the basis of the characteristics of the public group.

Indeed he states that *common* private needs (which require, for their satisfaction, the association of an individual with many others) become *public* needs when they are satisfied by a public group or by the State. And, *vice versa*, a need becomes private if the group that historically meets it is a private one. In brief, Seligman stated that the concept of public group introduces that of public needs.

After having introduced in the most stringent manner the *subjective* element of the difference between private and public needs by making the public character of needs dependent on the public nature of the subject that meets them, Seligman went on to specify the *characteristics* of the public group. Furthermore, in so doing he also makes reference to the intrinsic or *objective* characteristics of needs met or services offered by the public group. This, however, is more a generalisation of typical elements verified “a posteriori” or historically rather than an “a priori” differentiation based on deductive reasoning. For this author, the State, or public group: 1) satisfies needs that are essential for the life of individuals living together; 2) is *universal*: that is to say, it operates over the entirety of a determined geographical territory, for *all* members of a given community (unless displaced); 3) applies *coercion*, in the sense that once an individual belongs to a public group he can no longer leave the group as the relationship is *indissoluble*, in the sense of obligation of the individual to remain as part of the group (unlike the case of private groups: societies, associations, etc.).

In addition to these *positive* characteristics of the public group, Seligman suggests three others of prevalently quantitative rather than qualitative nature: 1) *non-reciprocity*, in the sense that the “do ut des” relationships that represent the real essence of exchange have limited application between individuals and the public group. The State can manage commercial enterprises and sell products and services to the individual, or it can provide specific services against payment in the form of taxes and duties. With regard to the overall taxation burden, however, the proportion represented by these fees is insignificant compared to the proportion that individuals must compulsorily pay to the public body. 2) The second degree difference in the public group is *indivisibility*. With this term we refer to the impossibility of differentiating the advantages the single individual benefits from. Unlike the case of an exchange between private individuals, where there is always a definite and uniquely verifiable advantage, in the case of the action of the public group the limits of divisibility of benefits are very

restricted. The differentiation refers not so much to the intrinsic character of private and public groups but more to the nature of the satisfaction they can provide; and often the public body satisfies essential needs (defence, public order, etc.), whose proportional benefit is difficult to practically assign to any single individual. 3) The third degree difference is the *non-measurability* of the benefits offered by the public group when the services are indivisible. Of course it is not possible to measure the benefit that two people can, respectively, derive for example from the police service, especially if we consider the person rather than the assets he owns; there are, however, cases of services that offer measurable secondary and specific benefits.

Seligman's analytical classification, based mainly on the public *nature of subjects* (State or other public bodies) that meet the needs of the community, satisfies the proof of historical experience, in the sense that it is always current. Public needs are the needs that the State meets: they therefore cease to be so when the task to meet the same needs is assigned to private groups. Only on the basis of a *subjective* classification is it possible to explain how, in the same historical period or moment, the same service (for example transport or police) is offered by public and private bodies in different countries. And also how, in the same country, at different historical times, the same need (for example rail and telephone networks, etc.) are *first* met by private groups (companies) and *then* by public groups (the State) and vice versa.

It must however be remembered that Seligman's qualitative and quantitative differentiation with regard to the characteristics of public groups or of relationships between individuals and public groups does not apply to all the needs satisfied by the group, as there are cases where *all or some* of the characteristics mentioned do not apply, even though there is financial activity aimed at the satisfaction of public needs. To limit ourselves to one characteristic (coercion), think of the various "degrees" in which it arises when the State meets needs by procuring the means with recourse to private, quasi-private and public prices, taxes, contributions and special duties.

To Seligman's qualifications, Fasiani (who conveniently did not want to linger on the differentiations of public needs on an objective basis, a real "muddle")¹⁰⁰ has certainly added some differential characteristics of the group (or body) that meet the community's requirements through its financial activity. Such characteristics or "connotations" *derive* from those of needs that are satisfied by the State or public group. What I have said about Seligman with regard to the verification of the *objective* characteristics of public needs, however, also applies to Fasiani.

He added precisely the following characteristics: a) *heterogeneity* and *variability* of the needs that are satisfied by the public group.

Unlike what happens in *private* groups that "normally" arise and operate for a *specific* purpose, to the point that once that purpose has been achieved the group can cease to exist, the needs satisfied by the public group are of the most *varied nature*.

The field of action of the public group can widen or shrink, even significantly change, without the group ceasing to exist. Even *coercion*, the element we mentioned earlier (Seligman), appears to be necessary because the needs to be met are heterogeneous and variable and there is not always consensus from all members of society.

Another characteristic of the public group, according to Fasiani, is b) *indefectibility*, not so much in itself, I think, because jurists have for some time identified this constitutional characteristic, but for the consequences that this characteristic has on the nature and extension, especially over *time*, of the needs to be met. So it will have at its disposal instrumental assets (for example: roads, railways, etc.) not only in view of the intensity of *current* needs, but also to discount the *future* needs of a numerically growing and increasing community.

Even though Einaudi accepted the differentiation on a subjective basis (public needs as those that the State takes care of through its specific financial activity) as a "last resort" or as inevitable as generally more univocal from an historical if not a logical point of view, he *discussed some*

⁽¹⁰⁰⁾ Op. cit., Vol. I, p. 31. The characteristics of public groups are explained on pp. 18-19 and following.

“connotations” or *characteristics* of the State with the aim of identifying the “historical” *limits* of the existence of such connotations¹⁰¹.

Actually, I think that the criticisms that Einaudi directs to the concept of the State to indicate that sometimes indefectibility (which would induce it to undertake works that span time periods longer than the ones that men normally take into consideration) is not one of its characteristics, should be directed to the governing class, for the State or to “rulers”. In fact, a class that considers in particular its own interest first of all will mainly (but not necessarily always) undertake works and will carry out activities relative to time periods correlated to the probability that that class will govern the State and will take advantage of it because it will benefit from it. Einaudi’s objection, however: *a*) refers to only a type of State that acts through rulers who are mainly concerned with their own interest or that appear to be so to contemporary rulers; *b*) does not take into account the possibility that, even in this hypothetical and historic case, the governing class succeeding to power may accept the legacy and continue the services put in place by the previous class (as rulers) exactly in relation to the aspect of its interest or general benefit that it might recognise in the same services (problem of degree and not of species).

The adjective “stable” used by Einaudi should be referred therefore to governing classes and not to States. Unstable would be those activity plans of rulers that alternate in power. Furthermore, it is clear that Einaudi is right when he explains that, taking advantage of the, in my view, apparent or presumed indefectibility of individual classes exercising State power, some of them propose public services that, for this very reason, appear (financial illusion) to meet the needs of several generations.

Whereas, later, historical exceptions enlightened by cases from the past and by hypotheses of incomplete or hypothetical facts are convincing. In the context of full State sovereignty, I think that, as these are exceptions, they do not fail the prevalent and generic type of State, and that comments of this type go beyond the assumptions of the author: *a*) it is not useful for the academic to accept the definition that public needs are so because they are met by the State in financial activity as the starting point for his reasoning. Indeed, by suggesting the investigation of the choice of needs that “must” or “should” or “would normally” be satisfied, the eminent academic goes back to the field of objective differentiations that aim to identify intrinsic and immanent (not historical but logical) criteria of separation of public from private needs. This assumption goes beyond the objectives of the clarifications in the article (¹⁰²); *b*) in focusing on the opportunity to study the traceability of some tasks to the State (objectives of State activity) and in assigning such objects of study to the expert of the science of finance, Einaudi expresses his own opinion and reveals his well-known awareness of the political and sociological premises of investigations in the relationships between the State and his citizens (taxpayers in this specific case). However, as he recognises, this goes beyond the definition of public need, even if indirectly it contributes to the illustration of its genesis, more from an historical than a logical point of view.

Fasiani answered Einaudi’s objections by clarifying his own reasoning and by illustrating the concepts introduced by Seligman in characterising the public group and the needs it satisfies (universalism, coercion).

Fasiani also made a differentiation between *historical* cases, which can be more or less explained by a *definition* aimed at settling the theory, and generic distinctions of a first approximation referred to abstract *types* of States or of public groups. Furthermore he has made a distinction between what is *marginal* and what is *essential*, what is *juridical* from what is *economic* in the concepts of sovereignty and universality, and has limited the concepts of coercion and indefectibility¹⁰³ to which I

⁽¹⁰¹⁾ In the “Rivista di diritto finanziario e scienza delle finanze” [Journal of financial law and the science of finance], December 1942.

⁽¹⁰²⁾ See: L. EINAUDI – *Di alcuni connotati della Stato elencati dai trattatisti finanziari* [About some connotations of the State listed by financial academics], in “Rivista di diritto finanziario e scienza delle finanze” [Journal of financial law and the science of finance], December, 1942.

⁽¹⁰³⁾ *Di alcuni connotati del gruppo pubblico e di una definizione dei bisogni pubblici* [About some connotations of the public group and a definition of public needs], “Rivista di diritto finanziario e scienza delle finanze” [Journal of financial law and the science of finance], June 1943.

refer students who have a particular interest in this type of discussion, as they are essentially and methodologically irrelevant to the object of a course of public finance economy.

It does not seem necessary to insist on these classifications that are not of direct interest to the economic theory of public finance. Seligman coherently states that he had wanted to integrate “the work of those sociologists who have not made any attempt to apply their theories to the economist’s life”. “The social theory of the science of finance” that the student can explore in the quoted source, according to Seligman, “sums up economists’ efforts to highlight the social content of their science”⁽¹⁰⁴⁾.

I don’t believe this task is pertinent to the competency of economists, even though it might shed some light on the facts. As I have explained before, public needs, such that can be hypothesised to be met over time and space by public bodies, are *factual data* or a premise to financial activity to the financial economy expert. They are of interest because they are correlated to *public expenditure*, as a quantitative element that gives content to problems of an economic character.

For the rest, it is sufficient to open a book on the general theory of the State to notice how, unlike the approach of even some of our own economists, the problems relating to economic, political, social and ethical, etc., *functions* that the State takes responsibility for, are studied by jurists with an historico-philosophical training that clearly defines, from the point of view of the genesis, the task of the public body in the interest of the community.

The origins of society with regard to the needs of the individuals who make up the “hordes”, “clans”, families, “tribes”, “people” in the Roman sense of “gentes” and the State above the people, with the explanation of the reason for their organisation (from the need for defence to that of the more efficient struggle for the necessity of life within it) have been amply illustrated in such juridical and historico-philosophical works, with listings of the objectives of the State, as functions of the *historical conditions* and of the *evolution of the awareness of a people*. And the purposes or functions, the “essential”, “fundamental”, “complementary”, “integrative”, “necessary”, “indispensable”, etc., objectives do not necessarily concur with economic ones.

For this reason, I will repeat, public needs are of interest as a general premise of the financial activity and as factual data in theoretical problems that arise because these needs determine public expenditure. This public expenditure, in turn, within the (economic, political, etc.) limits of the obstacles encountered in achieving the requirements to meet them, compatibly with the satisfaction of private needs, constitutes the first element that in itself gives content to the theory of interest in lessons of public finance economy.

Furthermore, this is the scientific position of the best and most current English output. Public needs are considered incidentally in defining public finance, that is to say, to indicate its premise or factual data: for the rest there are dense chapters relating to the concept logically correlated to public needs, that is, with *public expenditure*, that has a rational relevance because of its distribution, flow, effects, etc., in a treatment that deserves to be defined as a branch of economic science or public finance economy.

⁽¹⁰⁴⁾ Investigations of sociological character such as those by Seligman, Fasiani and others, could appear to be a *direct* contribution to the progress of the theory of financial economy when its partial sociology content is qualified, as in the manner of Gini, by the definition of *Economy* (see the essay, *Alle basi della scienza economica [At the basis of economic science]*, op. cit.).

However, as soon we consider examples of problems that are supposed to be the object of this science, and its definition, as having as its object the observation of social phenomena because they have “relevance to wealth”, not only do we find ourselves in the field of inductive research (which would not be an issue in itself) but we end up including in economic sociology the investigations of the “historical school” of economy, that is to say *historical research* that aims to establish historical laws in the economic field. In our case, as we are considering relationships with financial events, we end up admitting the *historical* character of research as it was considered by Seligman, Einaudi and Fasiani: that is to say, as systems not directly relevant to the object of financial economy, seen as rational deductions, essentially based on *hypothetical* concepts or idealisations.

II.

PUBLIC EXPENDITURES

The logical sequence of public needs and public expenditures leads us now to consider from which point of view this latter category, with objectively quantitative content, is considered in these lessons.

The warnings I have given with regard to the psychological category of needs have been given by others with regard to public expenditure. It has been stated that these do not concern *exclusively* financial disciplines. This is true.

The science of finance as economy, however, cannot limit itself, as some expect, to the consideration of the total level of expenditure as *fact* nor to concern itself only with the most convenient methods of obtaining revenues to meet this commitment. This is because the theme of expenditure strays into *other fields* of knowledge that, according to the approach in these lessons, we will not consider, even if they are characterised by the, in any case, tenuous qualification of social, political, etc.

I have already had the opportunity, in the *Introduction*, to broadly comment on how theoretical problems are influenced and the solutions modified by the simultaneous consideration of public revenues and expenditure, hypothetically. There are also problems where the limitation of the hypotheses to the collection of income alone is not logically legitimate, if the theoretical explanations claim to shed light on the complexity of real events, which need to be approached by considering at least the two aspects of the phenomenon – public revenue and public expenditure. These are not in any case, as G. B. Say suggested, “hail stones” that fall, hit and destroy, other than in respect of hypotheses that logically view pure theory investigations as partial, and that make them ultimately unreal, or rather unnecessary, in contrast with history. That is to say, they are relatively less fruitful, even when the hypothesis can be used in many theoretical problems addressing typical trends of the real.

With this I exclude historico-statistical references that, even if interesting in themselves, I consider *indirectly* in respect of the hypotheses and the uniformities that the phenomenon presents. For the purpose of information I will indicate other points of view from which *traditionally* public expenditure has been considered.

1) From an *accounting* point of view, it has often been said that – unlike the case of balance sheets for physical and juridical people, where expenditure is determined by the level of income – in public balance sheets expenditure is the *independent variable* to whose value variations the dependent variable represented by public income is adjusted.

This definition, indeed, is too rigid even if it does express the needs–expenditure correlation. In real life it is not uncommon for the State and other public bodies to forgo the satisfaction of new public needs or a fuller satisfaction of needs that have already been formally recognised as public, because of the (economic, political, etc.) difficulties in obtaining corresponding new revenues. In other words, the possibility of obtaining the necessary revenue is a *limit* to the expansion of public expenditure.

It is a different thing to admit, as we have done here, that the relationship between public needs and public expenditure is immediate and that there is a direct correlation between public needs and fiscal income. Indeed, recognising the convenience of getting the State to take responsibilities for specific tasks, that is to say, the satisfaction of determined needs, is equivalent to assigning some expenses to the State. Logically, ensuring income means are adequate to that expenditure follows the delimitation of expenditure: it is, however, necessary to keep in mind that this *succession* of times is not absolute, because the variable “income” (possibility of increasing it) often acts at the same time as a limit to the increase of public expenditure and to the extension of the tasks the State is responsible for.

2) Another point of view from which public expenditure can be considered is the *historico-statistical* one¹⁰⁵. This is the so-called “trend law” of the *progressive increase* of public expenditure.

An analysis of the causes of this law easily identifies the following determining coefficients: *a)* the increase of the *population* of States and other local bodies; *b)* the greater *cost* of the means to satisfy the same needs due to *technical progress* (for example the cost of military defence, with the evolution of mechanics, chemistry and physics); *c)* the trend of *price* increases due to the increase in *production of precious metals*, from the discovery of the main mines to now. In the years 1933–1941 and 1949–1950, monetary devaluations with high margins between costs and profit of mining activity have led to a significant increase in the production of gold and to increases in bank credit; *d)* the *monetary* devaluation of gold and goods, with the consequent increase in prices of goods and services; *e)* the greater ability to obtain extraordinary revenues (*public loans*) following the concentration of assets in the large financial markets; *f)* the evolution of *political constitution*, in the sense that the functions assigned to the State historically increase. From different points of view, the socio-democratic and the “corporate” approaches can lead to an extension of the functions of the State, to the benefit of the classes that are both more numerous and less affluent, or theoretically to the advantage of the nation overall (corporate State). The influence of this factor is not *continuous*; it may happen that in the alternating phases of politico-social directives, for specific historical times, the governing classes shape State activity according to liberal assumptions, on the basis of which the function of public bodies is significantly limited, so leaving the satisfaction of needs previously assigned to the State to private initiative.

These coefficients are among the main, historically verified, ones that have determined the progressive increase of public expenditure.

2a) Political (social justice and collective wellbeing) and economic (laws of economic development) circumstances have led to the realisation, essentially, of what Pantaleoni defined as the “transformation of specific expenditure into general expenditure”, following the assumption by the State of tasks that were previously the competence of private individuals, with a consequent increase in public expenditure. Clark, Arena, Villani and others, including myself, have then insisted on this, with regard to theories that explain the financial phenomenon which limits and criticises the concept that to assign a part of the dividend to public expenditure represents “consumption of wealth”. (Lesson courses of 1942 and 1944).

3) Another aspect from which public expenditure can be considered is that of their *classification* in:

a) *ordinary* expenditure to meet recurrent public *needs* with a certain regularity over time (these are most of those met in the course of an annual financial practice);

b) *extraordinary* expenditure to meet *extraordinary* needs that are often not forecast to be repeated (floods, earthquakes, famines, wars, etc.);

c) *federal* expenditure, met by the federal State in assembled States; *national* expenditure, in united States or those States adhering to federations (United States, Germany); *local* expenditure (met by the province, county, department, municipality);

d) *compulsory expenditure*, that local bodies in particular are obliged to authorise and meet, in financial practice; *discretionary* expenditure, whose activation is left to the contingent approval of the body, in relation to the variable circumstances of the event.

4) The classification of public expenditure in the context of the *nature of the public services* to which they correspond. Depending on the politico-administrative constitution, there will be as many categories of expenditure as departments dealing with public services, in central (Ministries) and in local administrations. Generally speaking, in all States it is possible to differentiate between two great categories: expenditure that is essential for the *juridico-political function* of the State (military defence, justice, public order, etc.) and expenditure relative to the *economico-socialological function* of the State (for material wellbeing and social and moral progress, for example: public

¹⁰⁵ For this I make reference to the specific and documented chapter in the already quoted work by L. Gangemi, *Elementi [Elements]* and other similar works, both old and new.

works, communications, demographic, industrial and agricultural development, protection of savings, public assistance, etc.).

In addition to the already mentioned points of view from which the public expenditure factor can be considered, there is the relevance of this factor to the purpose of the *systematics of financial theory*. This is what is of *interest* in these lessons, in respect of the type of problems we will be dealing with.

a) With regard to this, we will consider the expenditure in relation to the *classification* of the institutions through which the income has been obtained. Depending on whether the expenditure relates to divisible services, in respect of which it is possible to assign to a single taxpayer or group of them a measurable and, in any case, identifiable benefit, we will have *relationships* of (total or in part) *quid pro quo*. That is to say, there will be cases of private, quasi-private or public prices and taxes, contributions or special duties. In the case of expenditure for indivisible services there will be the institution of tax, as *means*. To a great extent, the two types of expenditure considered here correspond to the distinction made by Pigou¹⁰⁶ between “real expenditure” and “transfer expenditure” and that between “selling prices” and “grants” made by Dalton¹⁰⁷.

Other orders of problems of pure theory, some of which will be mentioned later, in which the element of *public expenditure* will be considered are those:

b) of the *economic effects of taxation*. With regard to this the repercussions of the collection of revenue and the *distribution* of the income of taxation will be similarly taken into account in some schemes;

c) of *fiscal burden*, which, as we will see, needs to be considered not only as a relationship between the taxation collected and national income (taking into account the population): the terms of the relationship also need to be modified in function of the economic, political, etc., utility of public expenditure for the community;

d) of the determination of the *cost* of the financial activity, of which public expenditure represents only the part that is objective and measurable in money;

e) of financial *productivism* in the sense that the State must take into account, if it wants to facilitate maximum production and the accumulation of wealth, not only the *modes* of collection of such wealth but also its *distribution*;

f) of the “risk” of taxation in the sense that, together with the eventuality of an increase of given taxes, there is the probability where individuals or a group of taxpayers are involved that the revenue is spent so as to benefit (increase in State demand and offer of instrumental services) specific groups of taxpayers;

g) of “*tax relief*”; with regard to this, a judgment on the opportunity or otherwise of tax relief must take into consideration the *use* that, respectively, in specific historical periods, the State or taxpayers would have made of the wealth passed from public (expenditure) to private use;

h) of the *contributory ability*. This can go from a generic concept of absolute contributory capacity, arbitrarily *presumed*, for example on the basis of the level of income or assets, to a more rational (relative) concept inasmuch as, in theory, account is taken (at a later logical and historical moment) of the special advantages determined by public expenditure even when, in a first approximation, these appear to be indivisible; this is meant in an approximate sense and without expecting perfect differential measurements;

i) of the variations of the tax of *taxation* in relation to economic *fluctuations*, as the nature of public expenditure has a varying impact on taxation sources, and the revenue of various forms of taxation, in the alternating phases of the economic situation.

I will not indicate other theoretical problems whose solution is modified by the impact of public expenditure. In the following chapters I will come back to some of those points indicated with letters a) – i) for analytical development. However, this brief list is sufficient in order to understand how significant the “expenditure” factor is with regard to the definition of financial theory; in the

⁽¹⁰⁶⁾ *A Study in public finance*, London, 1928.

⁽¹⁰⁷⁾ *Public Finance*, London, 1936.

same way the indications in paragraphs 1–4 suggest the importance of public expenditure for the solution of real and theoretical finance problems.

I will restrict myself here to remembering the problems that in the *Introduction* I indicated as belonging to the set of Keynesian logic, with regard to the content of the “fiscal policy”, for the part that is relevant to lessons of financial economy. I refer to some of the *effects* of particular modes of intervention of public expenditure on the development of economic forces aiming towards the equilibrium of a condition very similar to that of “full employment” of production resources.

I have already made a differentiation between discontinuous flows and possible purchasing power injected into the market (method of “pump-priming” in English and in particular American terminology) leaving then the system to proceed on its own; and continuous flows (in the spirit of the criterion of “deficit financing”), with the cyclical concept of State balance sheet and in particular with the vision of *trend* or of long-term evolution. In this second case public expenditure should have a permanent function of integration of the forces that determine the equilibrium of the economic system over time.

We will now see below that neither procedure, from the point of view of their *effects*, differs other than by *degree* and not in what are presumed to be its exclusive repercussions: *a*) on the volume of consumption assets whose increase is sought; *b*) on the volume of investments in instrumental assets promoted by the forecasted expansion of consumption, due to the intervention of public expenditure.

This *equivalence* is not, normally, admitted or considered in the treatments of public finance economy, nor in those of general theoretical economy.

III.

DECISION CRITERION OF THE EXTENT OF PUBLIC NEEDS TO BE MET: “PARETO’S SECOND CRITERION”

The State decides the extent of public needs to be met, on the basis of the calculation of the relative costs and benefits for the community.

In 1932¹⁰⁸, with the essay “*Intorno al concetto di costo dell’attività finanziaria*” [*On the concept of cost of financial activity*], I demonstrated how the calculation of the cost and benefit for the community passes from the single individuals to the State, in the determination of the quantity of public assets (indivisible services, mainly) to be provided¹⁰⁹. In this sense both elements of the calculation, as they are evaluated by the governing class on behalf of the community, are comparable. The costs are economic “damages” (objectively they are the negative effects of the tax collection; however, subjectively they are the sacrificed utilities) suffered by the citizens; and the benefits are the utilities enjoyed by the individuals using public services.

This process, implicit in the (subjective) judgment of the governing class, is represented in mathematical terms by Pareto, as we know¹¹⁰, who found *points* of maximum collective utility, from

¹⁰⁸ This paragraph is in Chapter II, paragraph 2, p. 202, of the printed Steb edition of 1952, as the author regretted not having included it in this edition.

¹⁰⁹ The evaluation of the cost and satisfaction may vary, historically, with the alternating political classes and their respective ideals, for varied reasons.

As I demonstrated in that essay, it is not only the effect of maximum *useful* satisfaction for the community that cannot be measured easily in a subjective way, as it is correlated with the subjective evaluation of the subject or governing class that carries out the calculation.

The cost of public services is not determined only (excluding nearly free personal services, such as militia, magistracy, etc.), by the total wealth subtracted from the consumption of private assets, but also by the negative *effects* caused by collection, such as economic damage as well as the psychological *sacrifice* due to the failure to satisfy some private needs and other effects such as diminished individual capacity of consumption or diminished effectiveness of productive factors, etc.

¹¹⁰ Pareto V., “Il massimo di utilità per una collettività in sociologia” [Maximum utility for a community in sociology], *Giornale degli Economisti* [*Economist Journal*], April 1913.

which financial activity cannot remove itself without inflicting useless sacrifices on the whole community or part thereof.

“In the judgment of the governing class, the collective cost will appear to be less than the collective utility up to a maximum point (Pareto’s *P*, in which the marginal cost is equivalent to the marginal utility). After this point the cost is greater than the utility and the effort appears disproportionate to the purpose.”

Given the importance, attributed by Fasiani (*Giornale degli Economisti [Economist Journal]*), among others, to the contribution of the sociologist (V. Pareto) to the explanation of the financial phenomenon, I will recall the *genesis* of the overall calculation of collection and expenditure, removed from the determining influence of autonomous and free decisions by individuals (and therefore irrelevant to the uniformities of political economy). This calculation is based on a function of public utility, so defined:

$$\varphi = \varphi (\varphi 1, \varphi 2, \varphi 3, \dots)$$

in which φ indicates the function of utility of national revenue, and $\varphi 1, \varphi 2, \varphi 3, \dots$ indicate respectively the functions of utility of individuals or social classes 1, 2, 3 ..., that make up the community.

For an easy understanding of the genesis of the calculation that moves from individuals to the governing class that imposes the consumption of given public services (in place of other private or public consumption) and the *pro quota* reimbursement of the cost of satisfying them (tax collection), it is necessary to keep in mind some premises that are here drawn from Pareto and which the reader can logically coordinate with regard to the following problem¹¹¹.

I) “If the utilities of single individuals were homogeneous quantities that could therefore be compared and summed up, our study (of the maximum utility for an individual or a community, when individuals or communities are compared to each other) would not be difficult, at least theoretically. It would be sufficient to sum up the utilities of the various individuals and this would give us the utility for the community represented by them.”

II) “The matter however is not that straightforward. The utilities of the various individuals are heterogeneous quantities, and a sum of these quantities does not make any sense: it is not possible; it cannot be considered. If we want a sum that remains correlated to the utilities of the various individuals, it is necessary first of all to find a way to correlate this to homogenous quantities, which can then be summed up.”

III) “The public authority operating logically (as a hypothesis) with the only purpose being to obtain a certain utility must necessarily compare the various utilities of the individuals that make up the community on whose behalf this same authority (governing class) acts. It compares all the utilities it is aware of.”

“Essentially, it roughly carries out the operation with rigour by pure economy, and turns heterogeneous into homogeneous quantities, through certain coefficients.”

IV) “Let’s suppose that we have a community in the condition of having no choice between having a very rich community with great inequalities in the income of its members, or a poor one with almost equal incomes. The search for the maximum utility of the community is probably closer to the first condition; the one of maximum utility *for* the community is probably closer to the second.”

“Let’s say it may, as the effect will depend on the coefficients used to homogenise the heterogeneous utilities of the various social classes.”

With this premise, let’s refer to the case in which the State or public authority carries out its financial activity in such a way as to obtain the maximum utility *for* the community in terms of material prosperity and satisfactions of a psychological nature.

With this premise, for the purpose of more clearly supplying the logical bases as to why the calculation must necessarily move from the individuals to the governing class of the State, with regard to the comparison of cost and utility of collection and expenditure mainly in the area of compulsory

¹¹¹ (Pareto, V. *Sociologia [Sociology]*, Chapter XII)

consumption of public services and the achievement of revenue through taxation, I will proceed with a symbolic schematisation.

To simplify the calculation of the cost of financial activity, as it has been configured in the previous pages (that is to say in terms of objective – money – and subjective – utility – quantities subtracted from the needs of private consumers and producers) and the contrasting utility for the community of the same financial activity, it would be possible to make immediate reference to the vision and approach of the previously mentioned State governing class in this regard.

In fact the representative, or representatives of the governing class, with a coordinated plan, form their own opinion about what they see as the cost attributed to all or to some members of the community and the benefits (or utilities in the wider sense) that they offer to the same or other members and groups of the community or to all members of the same community, by supplying public services with these revenues.

Let's define, for example, $\delta\varphi1$, $\delta\varphi2$, $\delta\varphi3$,....., as the variations of subjective utility (ophelimity) of the income of the various individuals or social groups, determined by collection of revenues and distribution of expenditure, according to the criteria of distribution of the governing class, with regard to itself and of individual members or of more or less extensive groups of the community.

The coefficients $M1$, $M2$, $M3$... indicate the importance (weight, quantity and positive or negative sign) that the political class attaches to the variations deriving from the public financial activity, in the evaluation judgment of utility for the community. These variable and diverse coefficients need indeed to be correlated to the variations of utility, as they are homogeneously recalculated by the government.

The financial activity will be carried out by the governing class to the point of maximum utility for the community, from which, to use Pareto's words, "it would not be possible to move away without inflicting useless sacrifices on the whole community or part thereof".

In the *judgment of the governing class*, this financial activity is coherently driven to the point of maximum utility for the community (point P in Paretian terminology). The property of this maximum point (P) is to make, in the margin, sacrifices and utility for the community equal in the judgment of the State¹¹².

In symbols, this property is expressed with the equation that cancels out the variations of utility for the community, as considered above:

$$0 = M1 \delta\varphi1 + M2 \delta\varphi2 + M3 \delta\varphi3 + \dots$$

where:

a) $\delta\varphi1$, $\delta\varphi2$, $\delta\varphi3$,... as we have already said, represent the variations of utility in the income of individuals or groups, according to the interpretation of the governing class. These variations are the differences (between tax collection and public expenditure) that respectively increase (if positive) or decrease (if negative) the initial incomes (before the public financial activity);

b) the coefficients $M1$, $M2$, $M3$... represent the weightings (i.e. $M1 = 0.3$) or relative importance, linked to utilitarian variations, that these coefficients homogenise, making them able to be summed up and comparable, in the general utilitarian calculation for the community, as defined by the State governing class¹¹³.

¹¹² Editor's note. In the following studies, this "optimum" will be redefined by d'Albergo as "Pareto's second criterion", to differentiate it from the "Paretian optimum" commonly used to define the optimisation of the use of assets in the exchange, that is to say in political economy, and which d'Albergo will redefine as "Pareto's first criterion".

¹¹³ For the purposes of simplifying the presentation of the genesis of the utilitarian calculation for the community, which is necessary for the rational explanation of the part of financial activity whose decisions are directly independent from the choices or decisions of individuals or groups of members of the community, we have not followed Pareto's atomistic analysis. This refers to the vision, every time, of individual members of the community around what they see as the utilitarian variation determined by the financial activity in the hedonistic equilibrium between them and other members and groups in the community.

An example will clarify the genesis that we have logically and symbolically focused on.

Let's presume that the State draws income from the community, in such a way as to collect taxes only or mainly from the richest members of the same community, to fund public expenditure (assistance, education and welfare, generally) through services that give an exclusive advantage to the poorest members or groups of members of the hypothesised community. In this case, the only way to justify the taxation of prevalently richer members is that the State governing class:

a) makes reference to the functions of marginal utility of the income of rich and poor members (in a simplified way, let's presume that they have the same trends and equal initial levels both for the rich (B) and the poor (A));

b) and applies then (to respective curves) smaller coefficients to the curves of the rich, compared to those applied to the curves of the poor¹¹⁴.

The limit to which this financial activity will be pushed will be given, in this model of a calculation carried out by the governing class on behalf of the community, from the equality, *in the judgment of the same*, of sacrifices and advantages considered overall. A further impoverishment of the richer members of the community will necessarily determine a lowering of the maximum utility point for the community. This would be the case so as long as the increase in the sacrifices of utility are not compensated for by a corresponding increment in the utility, given the appreciation and the hedonistic evaluations that the governing class contributes respectively to the richest and poorest members of the community.

This is a limit case that may diverge from the historical case that we tend to indirectly explain in these pages with reasoning of universal value. It can however be useful in clarifying the necessarily complex reasoning that, nevertheless, we have tried to make more accessible than the model described in Pareto's *Sociology* (Chapter XII).

In conclusion, a first logical innovation that we need to accept is represented by the fact that the judgment of the utilities of wealth owned and distributed in the fields of pure economy and of *non-taxation* public finance economy is hypothesised as being exclusively made by individuals; and by the fact that in the field of financial economy (that explains taxation) this judgment is made by the governing class for the State. In explaining the genesis of collection and expenditure of a part of wealth by the State we have recalled the concept of (maximum) utility for the community.

We will still need to make reference to hedonistic calculations that the governing class probably and most likely has carried out on behalf of the community, in judging the equality of contributions, for example in terms of progressive general and personal taxation, as opposed to proportional means.

In this simplified presentation of Pareto's logic, only the series of coefficients represented by M1, M2, M3, is presented. This represents the weighting that every time the individual members of the community would adapt to understand from their point of view the *quantum* of the variations that, according to the governing class, they would assign to their own utilitarian evaluation and that of other members of the community, in relation to individual events in the financial activity.

¹¹⁴ 115 (Editor's note - For example, as a consequence, where there is a given original curve AB (of both, at equal income), the curve for the rich becomes curve A while that of the poor becomes curve B).

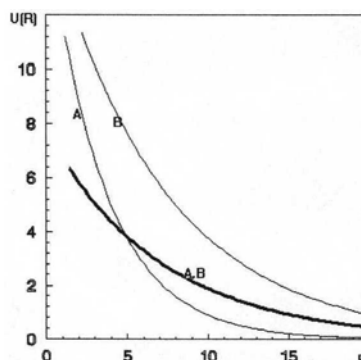

Remaining in the individualistic or atomistic hypothesis – that the utilitarian judgment is the competence of the individual, even in the *context* of phenomena that explain financial economy (collections and compulsory consumptions) – we should remember the criticisms that even suggest that the explanations we are abundantly involved with in these pages are irrelevant to this science.

The individualistic hypothesis was abandoned by Pantaleoni and by Pareto, both masters in methodology and gnoseology, when they respectively conceived, without leaving the field of economic theory, as we have already mentioned, collective models of hedonistic maximum points and maximum utility points for the community.

Pareto reached this model, as I mentioned in the *Introduction*, after having established that “the utilities of the various individuals are heterogeneous quantities, and that a sum of such quantities does not make any sense; it does not exist and cannot be considered. If we want a sum that can be related to the utilities of the various individuals, it is necessary first of all to find a way of deriving these from homogeneous quantities, that can be added up” (N. 2127, volume III, *Sociologia [Sociology]*). And the maximum of utility for the community is determined “independently of any comparison between the ophelimities of diverse individuals” (N. 2130).

Pareto assigns to the “public authority” the task of “necessarily comparing – without searching for specific criteria – the various utilities”. “In essence this (authority) carries out a rough operation that, with the rigour of pure economy, homogenises heterogeneous quantities, through some coefficients” (N. 2131).

Pareto illustrated his criteria for the explanation of mass phenomena or events, not believing that his logical position was irrelevant to economic science; he did, however, write about it in the “Economist Journal” (1913) by making significant references to *Sociologia [Sociology]*.

As far as I know, no one has denied scientific content to the attempt to explain the utilitarian calculations that the State or the public authority carries out for the community precisely in the extremely subjective field of hypothesised variations of ophelimity of individuals and groups of members of the community. Generally speaking, Pareto and the author of these finance lessons have not sceptically given up, declaring the impotence of economic science in explaining a normal event of State action, as Einaudi would suggest.

It is really not clear why the introduction of the variable of subjective utility of wealth cannot be analysed theoretically in the explanation of the fiscal event of proportional, regressive and progressive taxation. That is to say, it is sufficient to adjust the hypotheses and not insist exclusively on those with an individualistic character, but use others that, as I have said later, take into account the sociality of subjects or individuals. These should not be considered only or exclusively as “stranded Crusoes on a desert island” but as individuals recognisable from the real life of social complexities, with psychological characteristics, pleasures, choices, utilitarian evaluations sometimes dramatically transformed by social coexistence: the mass problem, on the other hand, such as that of distribution of general taxation on the basis of, for example, criteria of objective (in money terms) or subjective (in terms of sacrifices corresponding to taxation) equality requires the hypotheses to be updated so that they can be used for an interpretation of the solutions of the tax problems and a plausible explanation of these facts.

This is even more necessary, logically, as it is precisely modern events that are further away from those that are by now less relevant, even if they exist at the same time, that were and continue to be the subject of study for those, such as economists, who insist on the sceptical position in this field. Indeed, it is not only that the Crusoe figure belongs to fiction, but also that the individual subjected inexorably to the restriction of “*no bridge*”, that is to say, with no homogeneous connection or link between his hedonistic decisions because of the presumed extreme autonomy and diversity of pleasures and utilitarian evaluations, appears to belong to the memory of a past that will probably no longer return. I refer to the establishment in the world, in a very impressive manner, of the ideal of equality that pervades all forms of the ideal, more or less felt, of freedom in material but also spiritual life.

It is therefore not only that social evolution, in the context in which the subjects of the financial activity operate, makes logically necessary more fruitful hypotheses, in terms of their ability to interpret events, and makes, observing objectively, the events that the individualistic hypotheses of

more dated economists referred to as an historical memory. It is, however, necessary, in relation to new events as well, to have an hypothetical explanation that replaces the declaration of inability to explain or of gnoseological incompetence of this science whose objective, from the first pronouncement of a definition, I described as the explanation of the “modes” of distribution of taxation.

The hypothesis of a uniform mode to vary marginal utilities in function of the growth of incomes, for different individuals, on the basis of the individualistic vision, appears to some to be too far removed from the reality to be explained, to the extent of inducing the belief that “the discussion of the progressivity of taxation is not the task of economic science”. With such an hypothesis the “no bridge” situation is not an insurmountable problem. The rigid axiom of the inexistence of a *bridge* between individual hedonistic evaluations has the fault of really considering men, who in any case have much in common in terms of pleasures and choices, as little psychological islands. When hypotheses of this type are admitted (collective uniformity), it is on the basis of identifying explanations for mass problems, in relation to which the remembered traditional positions of many academics seem to be inadequate. Of course, mainly as an historical note to the theory, we also consider the hypothesis of differing variations of marginal utilities, without their transformation in the homogeneous judgment of the governing class.

CHAPTER II.

PUBLIC REVENUE

I.

THE LOGIC OF THE SEQUENCE: PUBLIC NEEDS – PUBLIC EXPENDITURES – PUBLIC REVENUES

1) In treating public revenue, referred to as the financial activity of the State¹¹⁵, we will maintain the order of presentation indirectly derived from historical themes already covered, as they deal with public needs and correlated expenditure, and from logical themes.

In this chapter we complete the logical economic sequence we are primarily interested in: *a)* public needs; *b)* public expenditure; *c)* public revenue. It translates into the following proposition: *given* that there are public needs, meeting these needs translates into corresponding expenditure, and this is met with adequate revenue.

a) This does not mean that we insist on the vision that compares the relationship between revenue and expenditure, and vice versa, in the individual and public economy. This is a vision that, in a first approximation, is suggested by some, in the sense: I) that in private economy or finance, income, as revenue, “determines” the *possible* level of expenditure by the subject; II) and that expenditure “determines” the level of *necessary* revenue in public economy or public finance.

This approximate or sketchy vision could, in fact, present so many exceptions, considering the cases of behaviour of the economic subject, as to make it unable to be considered an understood and undisputed uniformity. The same can be said of the quantitative cases and limits of the hypotheses of adjustment of expenditure to revenue, in the behaviour of public bodies, as subjects of financial activity.

Furthermore, in the first case expenditure does not mark the limit of revenue, as the individual subject can tap into the accumulation of previous income: in other words, savings. And when the balance of revenue and expenditure cannot be achieved, even by accessing savings, then it is possible, even in individual activity as studied by political economy, to make recourse to loans.

β) What technically differentiates, according to some, the two fields of action is the possibility of: *a)* *loans from abroad*; *b)* recourse to the type of loan represented by the advances on the part of the issuing institution, to such an extent as to cause *inflation* and transform the State relationship to a debt in relation to indirect taxation, to redistribute purchasing power between categories of beneficiaries of income on the market.

To be precise, if we disregard the objectives or the nature of the needs to be met, from the point of view of the methodology of financing and the economic effects of such financing, it can be said that in private economy also: *a)* loans from abroad are possible, through contracts with private groups or with institutions created by the State (as we can see with regard to current experience with loans awarded by the United States); *b)* furthermore private individuals also can, like bank systems, finance their needs with inflation, both through an expansion of the volume of their credit, and through rediscounts and advances that are not promptly controlled and restrained by public competent authorities. Let's consider the genesis of “forced saving” in its genuine and original formulation, which I attribute mainly to Keynes–Pigou. We can observe how price increases can be caused by an expansion of credit which makes available a (practically significant) increase in purchasing power to some individuals. These price increases can compel other beneficiaries of income-consumers to give up some forms of consumption, leading to enforced savings. The redistribution of purchasing power determined by inflation caused by the State has a similar effect, if we consider an in-depth analysis of the modifications in the economic equilibrium.

¹¹⁵ We make implicit reference to lesser public bodies that undertake financial activity on a smaller scale even when dealing with problems of State finance. These problems are logically no different from those affecting lesser public bodies, even though in this context we will often refer to the State as the operating, historically and theoretically hypothesised subject.

γ) Another point of view from which, according to some, there is a “marked difference between the means of finance and the means of economy” is represented by the belief that “the means of finance are not relatively scarce but practically abundant”, that “means are relatively abundant” with regard to public objectives, or that “the means of financial activity are *practically abundant* vis-à-vis the occasionally relatively limited objectives”¹¹⁶.

This idea of Griziotti's, also favoured by others, needs a clarification. Indeed it includes some terms that allow us to think in a very different way, depending on their use.

Or it becomes an issue of degree (abundant) in direct reference to specific real cases (practically). With this hypothesis it is possible to respond that private economy offers examples of abundant means with respect to the needs of individuals and private groups, comparing diverse situations or different relationships between needs, objectives and means.

Or it is possible to think on the basis of *absolute* data or total quantities. It is therefore necessary to abandon the term “relatively” that, on the other hand, the same Griziotti introduces in this reasoning. This cannot be done without contradiction; in fact the author feels the need to state “that the politician, through analysis and synthesis of factors that have a wider scope than those used by the economist, will be able to assess whether reaching set objectives is worth the economic cost of the erosion of incomes, in addition to the amount and nature of the expenditure and respective revenue”.

What is necessary to reconfirm at this point, in view of the further chapters on rational finance that will follow, is that this is in fact a theory of *relative* problems or, rather, based on *marginal* quantities, both of expenditure and revenue destined to meet it, in relation to the coexistence of private and public needs. In economy and in public finance, problems and theories are similarly based on utility and disutility compared to costs and benefits in objective and subjective terms (in other words of money paid and services and goods received or of utility sacrificed and utility gained) for *differential and marginal quantities*. This confirms *logical homogeneity* to problems of private economy and public finance even though, as we will see, there may be different subjects assessing or evaluating the quantities forecast. Each time these need to be balanced in order to reach decisions or make choices in the field of private activity (for traders, consumers, producers) or public financial activity.

There is therefore no place for criteria of scientific differentiation from this point of view. This is all the more so because historical observation (if not historical verification) allows us in fact to realise that it is not contradictory to limit the activity of the State (a concept defined as liberal-individualistic) even if there is no “limitation of means”, as Griziotti would have it. It is in fact this realisation that supports the validity of my logical position: that is to say, (limiting myself to considering the economic aspect of the problem¹¹⁷ and in conformity with the purposes of this treatise) – as precisely, when “means were not limited” (Griziotti's words), restrictive concepts of the activity of the State were in force. This was so because the judgment (of the fruitfulness, productiveness, *relative* utility, etc., of the destination of parts or increments of means for public objectives or to public expenditure) induced those (using comparative calculations of painfulness and utility) to believe that it was relatively less convenient that private subjects act in the area of satisfaction of private needs, compared to the destination of the same means to public needs, by the State). These are “states of consciousness” that presume utilitarian calculations in the field, precisely, of *relative* value and in the *marginal* sense.

Of course, no “value judgment” (on the “goodness” of such an attitude in the protagonists of history) is expressed in this context, but we clarify the *homogeneity of logical processes*, in the rational interpretation of the behaviour of subjects, both private and public, in comparing means to

¹¹⁶ *Mezzi dell'attività economica e mezzi della attività finanziaria [Means of economic activity and means of financial activity]*, in Studi in memoria di G. Masci [Studies in memory of G. Masci], vol. II, Giuffrè (Editor), 1943.

¹¹⁷ I actually exclude the influence of political forces. This is not because they might not have been determining forces as passions, or feelings and interests, but because of the impossibility so far in making theories about this, judging from the current state of development in political and social science.

objectives, in the field of private economy and of public finance by treating, in both cases, *marginal* problems.

2) Even if some admit the historical and logical priority of public expenditure, directly linked to the historical and theoretical formulation of public needs, not all treatises of the science of finance derive rational consequences from these. So that, instead of giving priority to public expenditure *first of all* and *then* to revenue, the reverse procedure is followed. This has no logical meaning if it is not compared with a sequence other than the one at the start of No. 1 of this chapter.

Furthermore, the order of presentation of economic problems of public finance, in these lessons, is also dictated by a need that is both educational and of real logic.

Indeed, the reference to public expenditure must logically *come first*, because: 1) the *direct* and divisible *benefit* that is derived by individuals (against their *free* demand) from the offer of State and public goods and services generally; 2) and the more or less divisible *indirect benefits* that are derived by the *compulsive* consumption of public goods and services contribute to coherent determination of the *mode* and *quantum* of public revenue.

Furthermore, the experience from previous courses of lessons has highlighted that, in the critical presentation of “the theories aiming to explain the financial phenomenon”, these theories *first* illustrate, even if only in part, the *limitations* of public *expenditure*, and then the *modes* of obtaining the revenue, with particular reference to the sums compulsively collected implicitly in relation to the greater importance that fiscal revenues have on the balance sheets of modern states. That is to say, that the modes of revenue are established *at a later stage*: by private, quasi-private and public prices, taxes, contributions, special taxes, general duties. Such modes of obtaining revenue, in addition to the rationally explained *quantum* of expenditure, presumed *modes* of expenditure and could end up being *examples* of financial institutions. This is particularly relevant to public revenue, correlated to expenditure, and explained within certain limits through the traditional presentation of these theories.

Indeed, for the most part these today represent the subject of history of the science because their contribution to the explanation of the fact of public finance, in which we are here interested for analysis of public revenue, is limited, partial and often null. Those who are interested in the development of the history of theories will find this matter exhaustively covered, with bibliographical data, in the quoted *Elementi [Elements]* by Gangemi, who has merit from the point of view of the art of writing treatises, or other manuals and treatises.

These “theories” converge, more or less adequately, in explaining parts of the phenomenon, respectively focusing on the sphere in which the *voluntary nature of the demand of consumption* of public services dominates. Forms of revenue that do not include the compulsory nature that characterises tax contributions stand against this demand.

The same theories are aimed at explaining the part of the financial phenomenon relating precisely to the compulsive collection of duties, in relation to the generic and indirect and indivisible benefits that derive from services whose consumption is compulsory, and for which public expenditure has been deployed.

Given the character of these lessons, influenced by the current pure economic theory that systematically finds new application or treatment, it seems logical to limit the assumption of differentiation criteria of public revenue to those that will subsequently be proven to be rationally sufficient. It is also a greater clarification of the logical bases of this science without risking the confusion deriving from numerous historical references to dated theories.

I will start by saying that these revenues must be differentiated into *ordinary* and *extraordinary*, depending on whether: 1) the State uses them to meet continuous and predictable needs, whose responsibility to meet it takes on through public expenditure and by obtaining adequate revenue; 2) they represent, respectively, income for discontinuous and non-predictable needs.

Here we focus our attention on ordinary revenues, and will reserve the problems of extraordinary finance, characterised by expenditures and revenues that do not recur periodically to a dedicated chapter. Having said that, I make reference to the following fundamental relationships between public expenditure and the relative State services, on the one hand, and the corresponding public revenue.

R. a) The relationship between:

I) type of goods and services, offered freely for its members by the State and other subjects active in public finance, and connected benefits or utilities directly obtained from them and comparatively evaluated by the individual members or groups of members of the community, on the one hand;

II) and on the other, the prices requested by the State and freely accepted by individuals, without obligation of consumption respectively of the goods or services;

III) allows a rational and economical explanation of the consideration of public revenues *without fiscal nature*.

R. b) The relationship between:

I) goods and, in particular, services (in the current reality to be scientifically illustrated) whose *consumption* the State makes *compulsory*, with a benefit that is: a) direct, predominant in the community, and indirect but *measurable* or at least *divisible* and relatively less relevant to individual groups as members of the community; b) direct and prevalent in the community and indirect and indivisible for individuals, on the one hand;

II) and coercive contributions, collected on: a) individuals and groups of members of the community; b) charged to all members of the community (with the exceptions that are historically foreseen by positive legislation, which is not of interest in this context), on the other;

III) allows the explanation of public revenues characterised: (α) by the obligation to *consume* goods and services; and (β) by the obligation to *contribute* to the reimbursement of the expenditure that the State, or other active subjects in public finance, takes responsibility for, or by compulsory collection. These [α] e [β] are characteristics that allow us to identify *public revenues of a fiscal nature*.

II.

PUBLIC REVENUES FROM THE POINT OF VIEW OF THE MEMBERS OF THE COMMUNITY WHO DEMAND OR EXPERIENCE THE CONSUMPTION OF PUBLIC SERVICES

A) – In a first logical moment, in considering the application of uniformities or laws derived from pure economic theory, from the *point of view of individual members or groups of members of the community* as hedonistic consumers and as producers of goods and services, I will consider the *logical validity* or the *non-logical validity* of the extension of the following theoretical laws, already known to students, as a criterion of differentiation of public revenues:

I) *levelling of marginal utilities*;

II) *levelling of marginal productivities*.

According to the preceding chapters (where we insisted on the theoretical character of public finance economy) it might appear logical to input the term representing the relationship (between goods on free demand and “prices” fixed but not imposed by the State) (that is the relationship sub *R.a* on the preceding page), directly into the equations that characterise the equilibrium of the consumer and the producer.

It is, however, necessary to consider the repercussions that the hypothetical relationship sub *R.b* (see on the hypothetical relationship sub *R.b* will *indirectly* have on *R.a*).

In the first case (*R.a*) public revenues rationally classified as *not having* characteristics of tributes in the sense indicated above will be identified; the second case (*R.b*) will focus on public revenues *with* a fiscal nature.

I) The first of the two uniformities¹¹⁸, in other words the *levelling of marginal utilities*, was considered in the previous edition of these lessons (and also in the one before) in a discriminatory

¹¹⁸ Even though this uniformity should be known to students who have attended introductory courses of (pure) political economy, I will briefly recall the model, with reference to consumption and also to public as well as private goods and services. This hedonistic model, according to Gossen, Jevons and Edgeworth (in the first instance), can be succinctly stated by saying that, according to experimental psychology, when an individual who has at his disposal a certain quantity of wealth, divisible in equal parts, and continuously

dedicates repeated units of this to the satisfaction of a certain need, he experiences a progressively decreased satisfaction from this. Similarly, the same individual will apportion his wealth so as to satisfy the most intense needs first and then those that are less pressing. If we hypothesise infinitesimal units of wealth, the marginal degree (or relationship between the utility of a certain wealth and its quantity) is measured by the relationship between the infinitesimal increase of the overall utility and the corresponding infinitesimal increment of the quantity of wealth.

This trend law (similar to that relating to *total* utility, considered as an *increasing* function of wealth) is, however, *abstract*: in practice we know very little of the very diverse psychological evaluations carried out by individuals with regard to the use of wealth at their disposal.

Leaving aside the psychological premise, Menger and the economists of the Austrian school of thought focus on the *logic* of the consumer as *homo oeconomicus*, guided in his utility judgments only by perfect reasoning.

Having postulated the preceding premise, the perfect hedonist will seek the condition of *equilibrium* that will assure him the *maximum utility* in the distribution of wealth *among the various types of consumptions*. This condition can be considered to have been reached when – assuming *equality of price* of the various goods – the *final* degrees of utility are evened out. Menger's table, therefore, lends itself to the "registration" (Einaudi) of voluntary decisions on the part of the consumer with regard to private goods.

The application of this economic trend law in the attempt to explain the financial phenomenon is historically admissible because it is assumed, on the basis of the active demand and the voluntary nature of consumption, that the individual is able to appreciate the utility of both private and public goods and services so as to *distribute wealth to private and public consumption and so achieve the equality of utility of the marginal units of wealth respectively destined to the satisfaction of private and public needs*.

To illustrate this theory we use the already mentioned Menger's table, assuming public and private goods and services, as well as the wealth available to each consumer, to be divisible into infinitesimal units. The trend law just mentioned shows that successive units of goods and services have a decreasing importance. Let's assume that the various needs have different intensity and that each intensity is represented by relative empirical indices *a, b, c, d, e*. These indices therefore indicate the satisfaction that the individual derives from having successively and continuously assigned (equal) units of wealth to various (private and public) goods and services.

For the purpose of formal clarity public services are shown *after* private goods. It is, however, clear that public goods are included in the private goods desired by individuals.

<i>Units of wealth</i>	<i>Private goods groups</i>			<i>Public services</i>	
	<i>a</i>	<i>b</i>	<i>c</i>	<i>D</i>	<i>e</i>
1	10	9	8	7	6
2	9	8	7	6	5
3	8	7	6	5	4
4	7	6	5	4	
5	6	5	4		
6	5	4			
7	4				

After the distribution of available wealth to public and private consumptions, the individual must be in a condition of *maximum* utility (where marginal utilities are evened out). Therefore, if we presume that the individual has at his disposal only 10 units of wealth, he will commit them only to the satisfaction of private needs, assigning 4 to group *a*, 3 to group *b*, 2 to group *c* and 1 to group *d*. This is so because the intensity of private needs is higher than that of public needs in Menger's hypothetical model.

If, however, 20 units were available, some units could be assigned to those public services whose utility (index 6) is higher than that of some private goods (5 and 4). Therefore, by distributing 20 units of wealth (or income) so as to even out marginal utilities, he would use: 6 in purchasing goods from group *a*; 5 from group *b*; 4 from group *c*; 3 from group *d* (that is to say 18 units in private consumptions) and 2 in public services (group *e*). Indeed only this type of distribution achieves the condition of maximum satisfaction of needs, where the *marginal utilities are the same* (index 5) *for all consumptions*.

Any movement away from such optimal distribution would lead to a *loss of utility*.

The following representation is achieved in the most rigorous and analytical form within the hypothesis, corresponding to reality, that the prices of the various goods are unequal. In this case, to achieve a condition of

way, to *deny* that it could be applied to explain the financial phenomenon, in the area of services whose consumption is compulsory and whose benefit is indivisible.

From the point of view, first of all, of the *positive* attitude of this uniformity to explain financial events and institutions, it can be stated that the uniformity contributes to the justification of the following modes of obtaining revenues, from the point of view of the individual members or groups of members of the community.

They are characterised by the following: 1) *by the price or expected payment, determined "a priori"*, whether this results from the conditions of free competition in which the State operates, as provider of goods and services, or because it is fixed by the State, which maintains its monopoly with regard to the supply of services; 2) *by the freedom* for the member of the community (or group of members) to *consume* (or otherwise) goods and services, for which they have the *option to demand*, on the basis of utilitarian evaluation with regard to the type of goods and services and of the quantities that, in the context of equilibrium of the *hedonistic consumer*, it appears to be useful to demand.

These extremes occur, generally, in the following modes of obtaining revenues that the public body uses, and that can be listed as follows:

private price;

quasi-private price;

tax (in the non-fiscal sense and corresponding to characteristics of 1) and 2) indicated above).

II) The *same modes* used to obtain revenues by the State, such as prices and payments for goods and services requested on the basis of a utilitarian calculation by members of the community, can allow the extension of the *levelling of marginal productivities* law or uniformity if we consider the members and groups of members of the community who request the consumption of such goods and services offered by the State without coercion, as *producers* who implement combinations to rationally reach the result of "production".

No doubt that, *directly* [and not as *external economies*, which we have covered previously in par. VIII¹¹⁹ (of the Introduction) to indicate the *indirect* fruitfulness of the State function for production] goods and services offered by the State are *complementary*, as requested by the "choice" of members and groups of the community, operating as producers. They *may* take into account goods and services offered by the State in situations of competition and of monopoly, in a manner not unlike that in which they behave towards other goods and services, in evaluating their productivity and prices paid for them, with regard to the best organisation or combination of single factors, to which State ones are added. These can represent goods (buildings, land, occupiable areas, etc.); or services (post, telegraph, railways, etc.), of which some (administration of justice, education) are organised so as to offer protection of rights and credits, or to allow the cultural and professional education of entrepreneurs in the widest sense of this term. As these offers are freely taken into account, because of autonomous choices corresponding to the best coordination of productive factors, among others, then combinations (with work, prime materials, capitals and various services) of State goods and services

equilibrium for the perfect hedonist, it is necessary that *marginal utilities are levelled with prices: that is to say, they are proportional to prices*: in other words, that weighted marginal utilities are evened out (with prices). If $(a, b, c, \dots n)$ is the total utility corresponding to the consumption of goods and services; $\frac{\delta\varphi}{\delta a}, \frac{\delta\varphi}{\delta b}, \frac{\delta\varphi}{\delta c}, \dots$

$\frac{\delta\varphi}{\delta n}$ are the final degrees of utility (partial derivative), and P_a, P_b, P_c, \dots . If P_n are the prices of the aforementioned consumptions, the hedonistic consumer will obtain the maximum utility from the distribution of his (monetary) income when:

$$\frac{1}{P_a} \cdot \frac{\delta\varphi}{\delta a} = \frac{1}{P_b} \cdot \frac{\delta\varphi}{\delta b} = \frac{1}{P_c} \cdot \frac{\delta\varphi}{\delta c} \dots = \frac{1}{P_n} \cdot \frac{\delta\varphi}{\delta n};$$

The same can be said for the other increments of both private and public consumptions, for which prices are paid or payment is expected on the basis of free choice or determination on the part of the subjects.

¹¹⁹ Whose content was in part referred to in my article in the *Rivista di diritto finanziario e scienza delle finanze* [Journal of financial law and the science of finance], IV, 1950.

without coercion of consumption, the mode and *quantum* of prices and payments requested for them by the State can also be contextualised in the logic governing production.

I refer to the already mentioned *levelling of marginal productivities* law or uniformity, which can be expressed by stating that: every entrepreneur limits the quantities of the individual factors used so that the individual marginal productivities (or increments in the product in relation to the increment of the production factor in question) are proportional to their respective prices.

The equations expressing this economic law were considered, with reference to indivisible State services and with an indirect advantage for entrepreneurs paying tax, in par. VIII of the *Introduction* to which we refer the reader to avoid repetitions of symbolic formulations.

The brief summary I give below of the typical modes adopted by the State, in its modern structure and financial policy (leaving aside the detailed historical references relating to the near and far past that the student can find in treatises of the science of finance), will give a typical *exemplification*, logically compatible with this explanation of the modes of being of revenues of the State and of other lesser bodies that conduct financial activity. I refer to the list above of: *private prices, quasi-private prices, public prices, taxes* (not fiscal).

The characteristics of these modes of procuring revenues demonstrate the applicability to them of the two uniformities that relate to the behaviour of members and groups of the community both as consumers and as producers of wealth, with free choice.

a) *Private prices*. These are those that individual private members and groups of members of the community, as hedonistic consumers and as producers, pay to the State when it offers assets, for example real estate, produce, or leases on urban real estate, or allows the occupation of public areas in return for rent, without imposing its consumption but each time taking into account the demand of individuals or private groups of the community.

b) *Quasi-private prices*. These are paid to the State for products of enterprises or industries that the State takes responsibility for in order to satisfy *simultaneously* the needs of the entire community. For the purposes of our differentiation, however, it is relevant that, for example, the products of the State forestry industry are sold at prices paid by private parties on the basis of their choice or freely formulated demand. In this case, too, there is no obligation to consume the forestry goods or product (wood). Leaving aside the destination of the price of the products of the State's enterprise, the State (by taking responsibility for the forestry enterprise) satisfies indivisible collective or common needs (as prevention of floods, landslides, facilitation of regular atmospheric precipitations, influence on the temperature and winds, etc.). The circumstance (that the State *immediately* and *simultaneously* offers the products on the market to those who make free request of them) does not give rise to an obligation to consume goods.

c) *Public prices*. They are the prices that the State applies to those who make free demand of public services, for example in the area of postal services, railway, telephone communications, etc., for divisible benefits, or those benefits that are deemed to have utility by members of the community in their role of hedonistic consumers or wealth producers.

In this theoretical case, too, by taking responsibility for providing these services, the State *immediately* and *simultaneously* satisfies indivisible needs of the community (traffic facilitation or exchanges, diffusion of culture, mobilisation of military forces, etc., and other objectives and needs (I will cover the issue of "offer" in the following pages).

d) *Taxes*. This is the denomination of various categories of public revenues. From the point of view of being of interest to us, in the light of the application of the economic theoretical uniformities indicated above, taxes are the payments that the State wants not only for the divisible services mentioned above (indeed cases of public prices are often defined taxes as tariffs) but also in the case of services rendered by the State administration or organisation. Typical cases are juridical taxes when members of the community have spontaneous interest in starting proceedings, or when asking for the service of education (in Italy lower and upper secondary school) for the autonomous or privatistic evaluation of the benefit or of the utility of such services in relation to the corresponding prices freely asked by the State, and called in fact taxes. [It is not necessary to specify, obviously, that the State satisfies indivisible public needs, in an *immediate* and *simultaneous* way].

B) The reader can check the compatibility and the coherence of the characteristics that recur in these modes of procuring public revenues. We have reviewed them briefly, with the two theoretical uniformities, relating to pure economy, designated as: I) *levelling of marginal utilities* and II) *of marginal productivities*.

In fact, the case of the modes of revenues indicated here by the letters a), b), c), d), have in common the freedom of choice and utilitarian evaluations, on the basis of prices and payments on the one hand and of types and productiveness of services on the other. This allows consumers and producers of wealth to proceed to combinations of equilibriums of hedonists and organisers of enterprises respectively, in the light of the laws that the pure economist has been able to formulate with regard to the behaviour of the two typical subjects here considered.

This approach (perhaps less explicit for others in the previous editions) to the differentiation between non-fiscal and fiscal revenues, respectively characterised by “non-obligation” and “obligation” of consumption of public services, has the merit of neatly curtailing discussion on the character of some instruments, through which the State provides the requirements to meet needs and public expenditure. [I am referring to the *tax* that, in particular in the juridical field, as I have already had reason to comment in previous editions, have had too rigid and unilateral definitions assigned to it. This is in contrast with the real different phenomenon, that is included under the same denomination, wantonly and inappropriately adopted by legislators. Someone in Italy has decided on the correction of a great part of these definitions (in terms of taxes) regarding real tributes and duties of this type, because its payment was coercive, without supply of specific services (except marginal and differential cases, such as the service of registration of deeds for the transfer of wealth. This reference confirms, once again, the difficulty in reconciling the economic and the juridical aspects of the scientific construction of financial activity, in the study of it from these two points of view.]

In other words, the nature of the tribute has therefore been identified with the coercion exercised for its *payment*, as if this were *always* linked to the *obligation to consumption* of the service. Finally Zanobini, in his *Corso di diritto amministrativo [Course of administrative law]*, Vol. IV (The means of the administrative action), stated that as the conclusions “are founded on the real regulation imposed on the various services by positive laws, it is necessary to reject any abstract criteria of differentiation and resolve the problem, each time, by taking into account the way in which the relationship is organised by its relative law”.

According to the clarification offered in these lessons, Zanobini correctly reserves the term *tributes* “to those revenues that the State obtains by imposing compulsory services to its components, without any particular utility being assigned to them, and by using the revenue only for general purposes of organisation, defence and progress of the entire system”. “Only these revenues can properly be defined as “tributes”: they belong exclusively to public law and are identified with the various types of taxes”. Among these are even included those tributes inappropriately called “taxes” in some, now dated, law texts.

I do not however see as coherent, in Zanobini’s work, the extension of the definition of *commutative revenues* to “designate those earnings – both in private and in public law – that derive from an exchange of utility between citizen and the State”, in the case of contributions, for example, of betterment taxes (which are on the other hand compulsory) only because they correspond to a specific counter-service. This is so because they lack the characteristic of “the utility that everyone requires and is prepared to pay for” that I suggest as an assumption of the payment of the tax (for the examples I have taken into account, that are compatible with this assumption). It is generally necessary to differentiate between the *obligation to make* the payment, which is obvious in the case of *private* contractual relationships *once the goods that are the object of the exchange have been acquired*, from the *obligation to consumption of services*, which is the discriminating element of my differentiation of revenues. It is only when this exists that we are dealing with tributes, as we intend them. In this way we avoid the wanton use of the terms “price” and “tributes” notable in the specific treatise by Ricca Salerno (*Studi sulla teoria delle tasse [Studies on the theory of taxes]*, Palermo, Società Editrice Libreria, 1928) of dealing with “fiscal obligation” in the case of taxes where there is no obligation of consumption of service. This latter was the case with M. Pugliese (*Le tasse nella scienza e nel diritto positivo italiano [Taxes in science and in Italian positive law]*, Cedam, 1930) and

with Griziotti, who *generally* considers them as compulsory tributes or collections only because the State reserves the right (monopoly) to supply some services. This inevitability of *payment* however also exists in the case of demand for services offered by private monopolies. Of course the nature of the tribute exists in taxes that, in the sense according to which I discriminate, are tributes and, in particular, taxes, in spite of the inappropriate legislative definition of “taxes”.

1) Indeed, when under the definition of *tax* are included cases of compulsory collections without a relationship with specific services offered by the State, and in particular *without the option for the individual to ask to use the service*, then we are operating in the fiscal field. This is so even if *the divisibility of the benefit* persists, as in the case of *betterment taxes*, “*a posteriori*”, after the State or other lesser body has *taken the initiative* of completing works of public interest, imposing the contribution *even if there has been no demand made* for these works through *private initiative*, or by those who, once the work is finished, are particularly advantaged by it, in terms of the increase in value to real estate adjacent to the area directly advantaged by it.

2) We have incidentally but logically defined *specific betterment taxes* offered by the real phenomenon, in other words financial legislation in Italy and other countries. These can be listed with the “tributes”, because of the coercion that characterises them and that is linked to the obligation to consume services.

3) Another separate category of tributes, as we will see from this analysis, is that of “special tributes”, which I have defined as “taxes charged to specific groups or social classes who perceive, as such, a particular benefit from the public service offered to meet primarily a collective need of the group in question”.

(For example, the supplementary contribution for road use which is, according to legislative precedents, due by those who in the course of their industry or commerce cause, through the use of “mechanical or animal traction” vehicles, unusual wear on roads. This is a group that particularly benefits from the public service of viability, which *also* meets general needs).

4) Finally, there is the *general tax*, as the main way of procuring public revenues. I have previously defined this as “the tribute that taxpayers are due to pay in money and sometimes in equivalent means to the State (and other lesser public bodies) for services of general utility, whose benefit is not generally speaking divisible or identifiable and whose cost, therefore, cannot be divided among individuals on the basis of the pure criterion of counter-service.

Now, going back to the rational economic criterion on the basis of which revenues are differentiated in this treatise, it is necessary to conclude that the two fundamental uniformities, that presume an exchange:

- I) of levelling of marginal utilities;
- II) of levelling of marginal productivities,

cannot rationally explain the categories of revenues that have been explored under the definitions of taxes (with fiscal nature), contributions, special taxes or tributes, general taxes or tributes: revenues that have fiscal characteristics.

I) α As far as the first uniformity is concerned, it is necessary first of all to admit that individual members of the community are not able to appreciate the importance of indivisible public services.

However, even admitting that this capacity exists in reality and that it can be admitted in an abstract and hypothetical setting, a situation that is not compatible with *tributes* to which correspond an *obligation to consume public services* persists. This situation, essential in the model illustrated on the basis of Menger’s table and the equations that generalise the law or criterion of equality of weighted (subjective) utilities in the previous pages, presumes *voluntary* “choices” by subjects, suggested by the perception of needs, evaluated by a presumed perfect economic logic, by the same subjects.

[It has been observed by Einaudi that the State, to have a reason to exist, must supply public services that are indivisible or require compulsory use, *before* the lack of satisfaction of this category of public needs is *felt*. Continuing along this line of thought, the individual would have no reason to

take into account, in his own hedonistic equilibrium, the need to assign a part of his income to the payment of public services designed to meet (public) needs that are not individually felt].

β – However, the point of view that is even less compatible with the application of the first uniformity consists in the lack of a *factor*, which must be known “a priori” for the settings of the calculation for the hedonist when he distributes his wealth to private goods, to the point of reaching the condition of maximum satisfaction, and must keep in mind also the assignment of a part of income for the use of indivisible public services through State coercion, which we have already established is a contradiction for this uniformity.

Indeed the missing *factor* is the *price* of public services, which is known “a posteriori” as a variable quote fixed by the State, for the reimbursement of the cost of indivisible services. When rationally deciding on the quantity of wealth to invest in public services, it is necessary to know: *a*) the wealth available for needs to be met; *b*) the pleasures or utilitarian evaluations of the individual subjects as hedonists; *c*) the prices of goods and services (according to the model explained above to consider the hedonistic model applicable to the explanation of types of revenues, linked with services and goods that members of the community can freely ask for).

So, in the field of services compulsorily used to whom the State and other lesser bodies assign (compulsory) contributions, special and general tributes, what we might conventionally call “imposed price” for the services corresponding to certain forms of revenue, *is not known* in advance as a *factor*. It does not determine “a priori” the *quantum* of demand of service, a demand which is hypothetically excluded, and which in any case could not be considered as a determined entity as we don’t know its price. This does not exist as such, but it is a quantity imposed “a posteriori” as a reimbursement of quota of the cost of the service of a compulsory service.

So the price that should be a *factor* becomes an unknown variable. Actually this is so in the case of an “imposed price” while for the tribute it is an *unknown* quantity, whose value is determined by the State that imposes its payment. This is done on the basis of criteria that are far from the logic of the genesis of prices and corresponding payments, when the utilitarian evaluation of the individual or members of the community as in relationships of exchange between private parties, can relate to a price that is known to the hedonist “in advance”.

It is not only, in terms of reimbursement of the cost of general services and indivisible utility and compulsory use for the members and groups of the community, the *quantum* that is fixed with criteria that, even in the case of the betterment tax, do not coincide with the genesis of prices freely accepted by users of services, but the utilitarian evaluation is also reserved to the State. It puts (through the judgment of the governing class, each time), their *own judgment of the utility, for the community* (in the Paretian sense I specify below) of public services, in place of the free judgment of individual members. These would be presumed in case we wanted to extend Menger’s table and the consumer equilibrium equations to financial economy to explain the modes and *quantum* of the wealth destined to State activity.

II) The *mutatis mutandis* reasoning is no different with regard to the impossibility of explaining the *quantum* with the uniformity represented by the levelling of marginal productivities. This quantum, in terms of a tribute, should be paid taking into account the productiveness or usefulness of services funded with *tributes* (and *not* prices and payments, which we have considered earlier as compatible with this uniformity that regulates production) whose payment is imposed, in relation to the obligation to use the same services. In this way private enterprises are prevented from choosing the quantum of public goods and services to be combined with private goods and services within the technical equation.

For this reason and for the lack of an “a priori” knowledge of freely paid prices, in the case of tributes, it is not possible to set the rational calculation *directly* by introducing values for public services and their prices, and use them in the equations that express the levelling of marginal productivity.

I will refer the reader to what has been said about the vision of public finance economy as a branch of applied economy in the sense intended by Pareto here (Chapter VIII, paragraph *d*) of the *Introduction*) with regard to the indirect influence (external economies) of public services for which tributes are paid for the compulsory consumption of the same services. In the meantime I will

conclude that, in the logical field of our hypothesis: α) consumption of indivisible public services; β) compulsory collection of tributes to meet their cost; the individual calculus of convenience (with regard to the use of public services) is completely impossible, in the conditions (α , β) here hypothesised. The State carries out the calculation of costs and benefits for the community in the sense we deal with below.

In 1932, with the essay already mentioned [which provided me with the classification (from which I have removed the meaning in the previous chapters of these lessons) even recently used by the followers of the “sociological school”¹²⁰], entitled *Intorno al concetto di costo dell'attività finanziaria* [*About the concept of the cost of financial activity*], which did not indicate my wider interpretation of the financial phenomenon that other academics had profusely acknowledged, I insisted on switching the calculation – of cost and utility for the community – from the individual to the State, from the identification of objective quantities to the determination of the entity of the cost and the utility of the financial activity (mainly intended for indivisible services), in a *relative* sense of judgment of the governing class for the State¹²¹.

“The notion of collective cost may therefore appear not to be capable of correct quantitative expression (such as objective extent) of the financial activity. The utility effect for the community is similarly incapable of this expression. Both elements of the calculation, however, appear to be comparable in the evaluation by the governing class on behalf of the community, since the economic “damage” (objective in the sense of the negative event of the fiscal collection) and the sacrifices (subjective because of the utilities sacrificed) they support, and the utilities enjoyed by the individuals, only then appear to be comparable homogeneous quantities”.

“This implicit process, in every period of time, in the (subjective) judgment of the governing class, has been represented, as it is known, in mathematical terms by Pareto (*Il massimo di utilità per una collettività in sociologia* [*Maximum utility for a community in sociology*], *Giornale degli Economisti* [Economist Journal], April 1913), who found *points* of maximum collective utility, from which financial activity cannot remove itself without inflicting useless sacrifices on the whole community or part thereof.”

“In the judgment of the governing class, the collective cost will appear to be less than the collective utility up to a maximum point (Pareto's *P*, in which the marginal cost is equivalent to the marginal utility). After this point the cost is greater than the utility and the effort appears disproportionate to the purpose”.

Considering the importance, among other factors, given by Fasiani (*Giornale degli Economisti* [Economist Journal]) to the contribution of the sociologist to the explanation of the financial phenomenon, I will recall the *genesis* of the overall calculation of collection – which I had for some time already synthesised – and expenditure, removed from the determining influence of autonomous and free decisions by individuals, in other words irrelevant to the uniformities of political economy. This genesis, which was mentioned in 1932 (assignment of different coefficients to the sacrifice and enjoyment of components of the community, *for* which the governing class wants to achieve a collective maximum utility), in fact appears in the subsequent editions of this course of lessons. I think it would be useful to present this idea again to clarify the overall calculation of expenditure and revenues, whose consumptions and payment, through tributes, is *imposed* on members and groups of the community.

¹²⁰By Griziotti, among others, in *Primi elementi di scienza delle finanze* [*Primary elements of the science of finance*], 1946, p. 26.

¹²¹The evaluation of the cost and satisfaction may vary, historically, with alternating political classes and their respective ideals, for varied reasons. As I demonstrated in that essay, it is not only the effect of maximum utility (maximum satisfaction) for the community that cannot be measured easily in a subjective way, as it is correlated with the subjective evaluation of the subject or governing class that carries out the calculation. The cost of public services is not determined only by (excluding nearly free personal services, such as militia, magistracy, etc.), from the total wealth subtracted from the consumption of private goods, but also by the negative effects caused by *collection* (economic damage) as well as the psychological *sacrifice* due to the failure to satisfy some private needs and other effects such as diminished individual capacity of consumption or diminished effectiveness of productive factors, etc.

For an easier understanding of the genesis of the calculation that moves from individuals to the governing class, that imposes the consumption of given public services (in place of other private or public consumption of goods and services) and the *pro quota* reimbursement of the cost of satisfying them (tax collection), it is necessary to keep in mind some premises that are here drawn from Pareto and which the reader can logically coordinate with regard to the following problem (*Sociologia [Sociology]*, Chapter XII).

I) "If the utilities of single individuals were homogeneous quantities that could therefore be compared and summed up, our study (of the maximum utility for an individual or a community, when individuals or communities are compared to each other) would not be difficult, at least theoretically. It would be sufficient to sum up the utilities of the various individuals and this would give us the utility for the community represented by them."

II) "The matter however is not that straightforward. The utilities of the various individuals are heterogeneous quantities, and a sum of these quantities does not make any sense; it is not possible; it cannot be considered. If we want a sum that remains correlated to the utilities of the various individuals, it is necessary first of all to find a way to correlate this to homogenous quantities, which can then be summed up."

III) "The public authority operating logically (as an hypothesis) with the only purpose being to obtain a certain utility must necessarily compare the various utilities of the individuals that make up the community on whose behalf this same authority (governing class) acts. It compares all the utilities it is aware of."

"Essentially, it roughly carries out the operation with rigour by pure economy, and turns heterogeneous into homogeneous quantities, through certain coefficients."

IV) "Let's suppose that we have a community in the condition of having no choice to make between having a very rich community with great inequalities in the income of its members, and a poor one with almost equal incomes. The search for the maximum utility of the community is probably closer to the first condition; the one of maximum utility *for* the community is probably closer to the second."

"Let's say it may, as the effect will depend on the coefficients used to homogenise the heterogeneous utilities of the various social classes."

With this premise, let's refer to the case in which the State or public authority carries out its financial activity in such a way as to obtain the maximum utility *for* the community in terms of material prosperity and satisfactions of a psychological nature.

With this premise, for the purpose of more clearly supplying the logical bases as to why the calculation must necessarily move from the individuals to the governing class of the State, with regard to the comparison of cost and utility of collection (in the widest sense of the word) and expenditure mainly in the area of compulsory consumption of public services and the achievement of revenue through tributes, I will proceed with a symbolic schematisation.

To simplify to the extreme, even in its symbolic expression, taking the calculation of the cost of financial activity, as it has been configured in the previous pages (that is to say in terms of objective – money – and subjective – utility – quantities deducted from the needs of private consumers and producers) and the contrasting utility for the community of the same financial activity, it would be possible to make immediate reference to the vision and approach of the previously mentioned State governing class at this regard.

In fact the representative, or representatives of the governing class, with a coordinated plan, form their own opinion about what they see as the cost attributed to all or to some members of the community and the benefits (or utilities in the wider sense) that they offer to the same or other members and groups of the community or to all members of the same community, by supplying public services with these revenues.

Let's define, for example, with $\delta\varphi_1, \delta\varphi_2, \delta\varphi_3, \dots$, the variations of subjective utility (ophelimity) of the income and distribution of expenses, according to the criteria of distribution of the governing class, with regard to itself and of individual members or of more or less extensive groups of the community. The coefficients M_1, M_2, M_3, \dots indicate the importance (weight, quantity and positive or negative sign) that the political class, in the evaluation judgment of utility for the community,

attaches to the variations making the cost and utility determined by the public financial activity homogeneous. These variable and diverse coefficients need indeed to be correlated to the variations of utility, as they are homogeneously considered and interpreted for the single members and groups of the community, from which the means are collected and to whom public services are offered.

The financial activity will be carried out by the governing class to the point of maximum utility for the community, from which, to use Pareto's words, "it would not be possible to move away without inflicting useless sacrifices on the whole community or part thereof".

In the *judgment of the governing class*, the terms of the calculus become homogeneous (that is, cost and utility respectively charged and benefiting the individual members and groups of the community, concisely considered in the synthetic vision of the State governing class), and this financial activity is coherently driven until the point of maximum utility for the community (point *P* in Paretian terminology) is reached. The property of this maximum point (*P*) is to make, in the margin, cost and utility for the community equal, in the judgment of the governing class of the State.

In symbols, this property is expressed with the equation that cancels out the variations of utility for the community, as considered above:

$$0 = M_1 \delta\varphi_1 + M_2 \delta\varphi_2 + M_3 \delta\varphi_3 + \dots$$

in which: a) $\delta\varphi_1 + \delta\varphi_2 + \delta\varphi_3, \dots$ as we have already stated, represent the variations of utility interpreted, with regard to individuals and groups of the community, by the governing class that has caused them through multiple acts (distribution of revenues and expenditure) of financial activity; b) the coefficients M_1, M_2, M_3, \dots represent the weightings or relative importance, linked to utilitarian variations, that these coefficients homogenise, making them able to be summed up and comparable, in the general utilitarian calculation for the community, as defined by the State¹²².

An example will clarify the genesis that we have logically and symbolically focused on.

Let's presume that the State draws income from the community, so as to collect tributes only or mainly from the richest members of the same community, to fund public expenditure (assistance, education and welfare, generally) through services that give an exclusive advantage to the poorest members or groups of members of the hypothesised community. In other words, the State governing class attributes lesser coefficients to the variations of utility relating to the richer classes from which the hypothesised tributes are collected, and will attribute higher coefficients of variation of utility to the poorer members, for whose benefit it has provided public services, sustained with tributes collected according to the hypothesis.

The limit to which this financial activity will be pushed will be given, in this model of a calculation carried out by the governing class on behalf of the community, from the equality, *in the judgment of the same, of sacrifices and advantages considered overall*. A further impoverishment of the richer members of the community will necessarily determine a lowering of the maximum utility point for the community. This would be so as long as the increase in the sacrifices of utility are not compensated for by a corresponding increment in the utility, given the appreciation and the hedonistic evaluations that the governing class contributes respectively to the richest and poorest members of the community.

¹²² As seen in the Chapter I, for the purposes of simplifying the presentation of the genesis of the utilitarian calculation for the community, which is necessary for the rational explanation of the part of financial activity, whose decisions are directly independent from the choices or decisions of individuals or groups of members of the community, we have not followed Pareto's atomistic analysis. This refers to the vision, each time, of individual members of the community around what they see as the utilitarian variation determined by the financial activity in the hedonistic equilibrium between them and other members and groups of the community.

This simplified presentation of Pareto's logic, in fact, only presents the series of coefficients ($M_1, M_2, M_3 -$ i.e. ($M_1=0,2 M_2=0,7, \dots$)) that represent the weighting that, each time, individual members of the community would adopt in order to understand from their point of view the *quantum* of the variations that, according to the governing class, they would assign to their own utilitarian evaluation and that of other members of the community, in relation to individual events in the financial activity.

This is a limit case that may diverge from the historical case that we tend to indirectly explain in these pages with reasoning of universal value. It can however be useful in clarifying the necessarily complex reasoning that, nevertheless, we have tried to make more accessible than the model described in Pareto's Sociology (Chapter XII).

With this explanation we have rationally accounted for the compulsory collection of quotes of wealth in the private sector and the compulsory consumption of public services: that is to say, of the domain in which the State activity denies the individuals the free choices of utilitarian decisions, replacing them with its own utilitarian judgment on behalf of the community.

III.

PUBLIC REVENUES FROM THE POINT OF VIEW OF THE STATE THAT: I) OFFERS AND II) IMPOSES CONSUMPTION OF SERVICES

This last reference to the State, whose governing class takes the responsibility for the calculation of the *quantum* of revenues and the criteria of distribution of the cost of public services, leads us logically to consider public revenues from the point of view of the mode and of the *quantum* of the cover or reimbursement of the *cost* of public services.

According to what was expressed in Chapter VIII of the *Introduction*, to differentiate the content of political economy (market economy) from public finance economy, it is necessary to explain the genesis of the range of private, quasi-private and public prices, (non-fiscal) taxes, contributions, special taxes, general taxes, from the point of view, precisely, of their limitations in procuring revenues for the State. The State is intended here as the subject that *offers* the possibility (with active demand by members of the community) or *imposes the consumption* (by demanding tributes) of public services.

A) Private or quasi-private price.

No particular comments are necessary with regard to the *price* that the State uses or adopts as a *private* entity, without concern about simultaneously and immediately achieving public interest objectives. This occurs in the case where the State carries out an activity, as we have seen, in order to achieve a revenue as a proprietor or entrepreneur, who adopts a market price, corresponding to the conditions in which hypothetically there is a competitive supply or in a regime of partial or total monopoly, in a market economy. The revenue is *then* used for public expenditure.

The same objective is achieved, with a quasi-private price, generally speaking, even if the State, taking economic responsibility for an enterprise, immediately satisfies public needs, as we have seen¹²³, for the objectives achieved by providing investments that private entities would not be able to achieve in the same way or within the same limitations. The case of forestry is typical, in that it requires long-term investment that the State is able to provide, in an economic sense, better than a private entity, as it can be imagined. This is so both because, as an indefectible body, it can manage the long periods required for productivity, and also because of the possibility to realise the "economic age" (Einaudi) after which the annual growth of the tree is less than the interest that could be gained by cutting the tree and investing the proceeds.

As a rule, the theoretical laws that generally regulate the supply of goods on the market, and in the example of forestry, mining, etc., products for which the State has taken the responsibility of production for the simultaneous achievement of other objectives of public interest, apply to this conventional and concise mode of qualifying the price. However, these are *compatible* with the role of the State, not dissimilar to that of the entrepreneur that achieves management revenues and profits, in the context of a market economy, in relation to *costs* sustained, as in the case made for the private price.

¹²³ I refer the reader to the previous paragraph where revenues through quasi-private means were considered from the point of view of the offer of goods by members of the community.

B) Public price

The case for *public price* that the State obtains, as total revenue, is very different from that of the management of public enterprises. With regard to this, generally speaking it has been accepted that the supply occurs on the basis of the condition that the total price is equal to the selling cost of products and services.

Someone has insisted, on the other hand, on the greater historical frequency that would implicitly be at the basis of the hypothetical formulation of the case where, in the context of a public price, the price is lower than the overall cost of production.

However, in this case [public price, that could be made to correspond to type III economic phenomena envisaged by Pareto (*L'economia matematica [Mathematical economy]*, op. cit., pp. 363-364), in other words "monopoly in the interest of the community"], it is possible to agree with the vision of this economist, a master also in the knowledge and interpretation of the real phenomenon. And it can be said, for this type of supply of services, "no relationship between the cost of production and the selling price *has been established "a priori"*"; this relationship, continues Pareto, results from the characteristic condition for this type, and consists of the realisation of a certain maximum level [of utility] for the community".

This takes us into the field of relativity of the evaluation of the State governing class, who may consider they have achieved the collective maximum benefit, by facilitating the maximum possible consumption compatible with social revenue and its distribution, when the supply of services occurs in conditions that are different from those that would be appropriate in the policy of prices in private enterprises, who aim to realise their own interest and its relative revenue (or profit).

In particular, the behaviour of the State can be characterised by:

a) the surrender of (total or partial) monopoly profit, by the State's limiting of itself to applying prices appropriate to cover the total cost of production: that is to say, compatible with the hypothesis of free competition. This allows, as we know, returns or revenues equal to the normal or market rate of interest, as it is presumed that this interest is included in the cost of production (like rates of amortization of plants): the case of the public price in its strictest sense;

b) the surrender of the cover of the total cost of production through a price or a multiple price policy (tariffs) that does not achieve the return compatible with the hypothesis of competition mentioned above (letter *a*). It is the limit case of the service offered at a loss, which is not normally something that happens in private enterprises and that, if it *tends* to be *normal*, justifies *taxation*, as we will see.

In hypothesis *b)* the State resorts normally to tributes compulsorily collected from the community to compensate for the deficit, if there is a *trend*, of the enterprises providing public services; and the *relationship* between the portion of the overall cost covered by revenues (prices) of the supply of the service, and the portion covered by tributes charged to users and in particular non-users of the service should give the *empirical measure* of the collective importance or of the utility that the governing class attaches to the extension of the consumption on the part of the members of the community who, otherwise, would be excluded from the consumption of services that the State might generally want to spread to the maximum.

In the previous edition of these lessons, the trend law was articulated with the expression *in the long term*, given the cover of the overall cost of production. Admitting with this, theoretically, *periods* of supply of services: 1) at prices that do not allow the cost to be covered; 2) at prices that allow the cost of production to be covered; 3) at prices that allow, for the time being, an excess on the overall cost (with the nature of revenue in imperfect competition or profit in a monopoly), an excess that is equivalent to a tribute charged to users, or to some of them.

What is important in this hypothetical case is the *trend* towards covering, on average, the cost of production both by instantaneously ordering the possibilities and by making intuitive reference to the dynamics of the policy of supply of public services and their relative prices (tariffs).

The problem of maximum advantage of utility, in the wider sense, that the governing class puts in place is that offering services at a public price becomes a problem of *degree*, in fixing the *quantum* of total service intended to be offered to the same community, in function of the offer price. Indeed this price can be differentiated for the purpose of the maximum extension of consumption to

given services by members of the community who, as we have seen, request them. The *extension of consumption*, aimed at the maximum level compatible with the income available to different classes of users and with a relative supply price that is sufficient, on average, to cover only the cost of overall production, would actually represent a way to satisfy a need of the community overall.

Normally this type of activity of the public supplier of services replaces a pre-existing activity or an activity likely to have arisen through private monopolistic or quasi-monopolistic initiatives, and this might shape private price policy according to the principle of personal profit and of net maximum utility. In fact the differentiation of prices potentially implemented by a private monopoly would respond to such a maximum utility or net earnings in the balance sheet of private enterprises: the quantity of overall or collective consumption of services offered on the basis of private personal profit may not coincide with the quantity of consumption that the public body might consider desirable to determine with a policy of offer prices that are *not conditioned* by the hypothesis of net, monopolistic, private maximum utility. [The finality of the simultaneous satisfaction of the needs of individuals requiring the services and of the community overall, whose needs it is intended to satisfy indirectly (for example, supply of service in particular markets or territorial sectors where private initiative, not motivated by public wellbeing objectives, would not offer it), can also be achieved in the case where the management of public interest companies is entrusted to private companies.

The regime of *concession* (which is typical in the case of transport services) may permit the achievement of the maximum advantage for the community with an offer price policy approved by the State and implemented by private enterprises. These may achieve returns whose maximum is *dependent* on the acceptance of a price policy such as generally would be adopted by the State if it were to take direct responsibility for the supply of services. This means instant competitive returns, theoretically; or, in a dynamic model, predictable in relation to the discounted variations of the interest rate].

The policy of multiple supply prices, in the context of the trend to cover the overall cost of production, normally takes into account, in the provision of services offered to individuals, the relationship between elasticity of demand and extent of the disposable income by large groups of beneficiaries of income, in the typical case of services offered in the offer conditions that characterise the institution of public price.

To represent the calculation inspiring public prices, in the previous edition I used Marshallian concepts, which I will quote, with regard to the elasticity of demand, with specifications gravitating around ideas that are not very dissimilar from those that inspire this type of revenue for public bodies. (*Principii [Principles]*, Biblioteca degli Economisti, pp. 160-164)¹²⁴.

I am referring to the following concepts, which are geometrically illustrated: *a)* “we will have the clearest view of the elasticity of demand by considering a social class at the time”; *b)* “when the price of something is much higher for any class of people, this class will only purchase it in small quantities”; *c)* “elasticity of demand is high for high prices and high or at least significant for average prices; it does however decrease with the lowering of prices and gradually it disappears if the decrease is such as to allow it to reach overabundance”; *d)* “this rule seems to apply to nearly all types of goods and for the demand of every class; the level at which high prices stop and low prices start is, however, different for different classes (social classes, writes Marshall, but keeping in mind the different groups of beneficiaries of income). The same happens at the level where low prices end and very low prices start”.

In the light of these considerations, it is possible to understand how an “overall demand curve”, representing the demand of “rich people”, of “middle class people” and “poor people”, hypothesising a price PQ , for quantity OQ may break into three curves corresponding to the demands of the rich, middle and poor classes represented in the same scale adopted for overall demand. From these, the sum of the demanded quantities

$$OH + OK + OL$$

¹²⁴ Implicit in this thinking is the concept of “consumer surplus” that is specified later and whose application in the area of differentiation of *fiscal monopoly* prices can similarly be applied here.



Figura 1.

can be inferred and drawn on the x -axis of the representation of overall demand, which therefore results from the horizontal superimposition of the partial demand curves, equal to OQ .

The preceding arguments, relating to a unique price, can logically contribute to the provision of a basis for the differentiation of prices, by adopting to a certain extent the modality of the supply¹²⁵. Similarly, this explains the inclination on the part of the State to supply some divisible services at price = cost and at a lower cost (less than the private one).

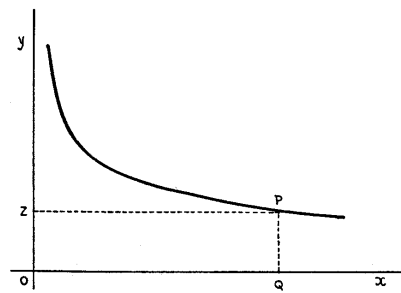

Figura 2.

The most typical example of a differential price (tariff) is that of the management of the railway service by the State. In this case the public body takes responsibility for the enterprise with general interest purpose, already mentioned, that is not fiscal but extra-economical (line distribution with strategic purposes, management of the service even in areas that are not economically viable, for the facilitation of production, exchange, wellbeing of the most numerous social classes, etc.) and then takes account of the just now mentioned premises.

I insist on the representation of the problem in a static model in which hypotheses are shown in their successive order, in the *instant* of time. It is, however, evident that for public services it is necessary to take into account the policy of consumable quantities and relative prices *over time*. As this demonstration wants simply to indicate the *sense* of a solution, it is left to the reader to understand the development of the real phenomenon according to real dynamics. Public service companies (State and public ones generally, and private concessionaries, compatibly with public interest) offer representative examples of this.

As they represent different levels of elasticity along their respective curves, the three different types of demand that are fused into the single demand curve justify a respective price, in the context of the policy of the offer on the part of the State that inspires its behaviour as a supplier of services

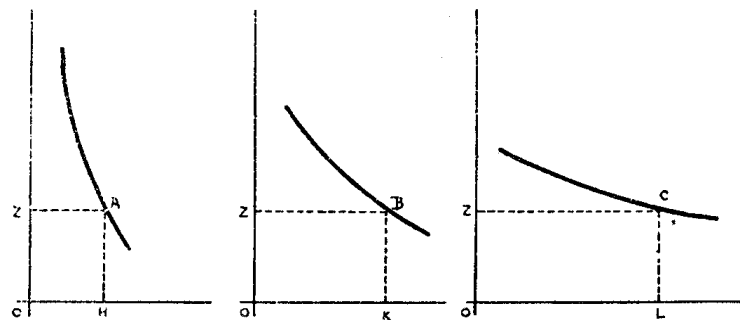
¹²⁵ In the case of distinction of the three classes of railway coaches, the “exploitation” “of consumers’ prejudice and vanity to apparently differentiate what is essentially a single service” is significant. It is the behaviour that Barone attributes to the monopolist in his treatment of multiple prices in *Principii di economia politica [Principles of political economy]*, p. 297.

with the objective to satisfy private needs and, as such, the simultaneous achievement of utility for the community.

Indeed, assuming the *trend towards covering the cost* of overall production, we identify three offer prices in Fig. 3:

1) pq , that – in the simplified hypothesis of constant costs (adopted here simply to make the geometrical illustration easier to understand), which is not normal for the specific example of the railway service – we presume represents the hypothesis of price in conditions of perfect competition. In this case there is a lack of differential gain in the shape of income or profit and pq represents the levelling of price = unit cost = marginal cost (meeting point of mm' with the demand curve DD' and costs SS' , here presumed constant), a levelling that allows, as we have seen, a return similar to the interest rate on the market.



Figura 3.

The quantity of supply at this price, that evens out the two costs and covers the total cost without income and profit – but which allows a return compatible with the hypothesis of perfect competition, as we have already mentioned – therefore results in Oq .

2) However, the hypothesised public objective of realising a maximum utility for the community may suggest the extension of production or supply and, therefore, the consumption of the service up to Oq' . In this way there would be a divergence between cost and revenue for the additional quantity qq' , represented by the area $p'cpv$, in function of the choice with criteria other than those of profit for private entrepreneurs, of price $p'q'$, which allows the extension or increase in consumption of the service by quantity qq' .

3) The hypothetical existence of the three demand curves, with different revenues from consumers, as adoption of the price pq may suggest for quantity Oq , and of price $p'q'$ for quantity qq' , with a *trend not to cover* the cost of production, can also allow a further differentiation (case III) in prices. This would allow *cover* of the total production cost, in other words, of quantity Oq' , produced and offered at prices pq (for $q''q$), $p'q'$ (for quantity qq') and $p''q''$ (for quantity Oq'').

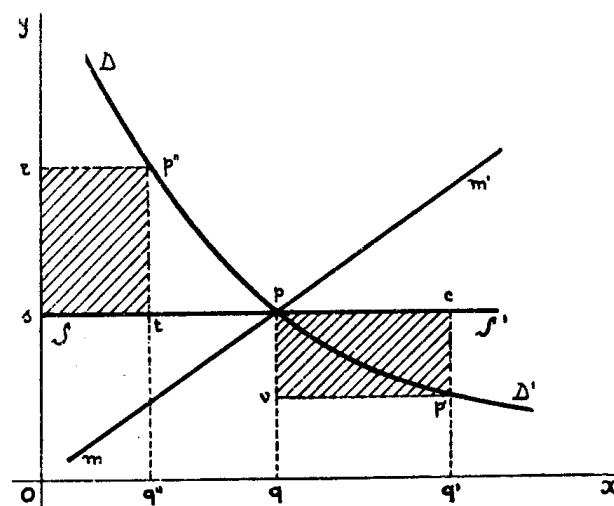
Indeed, the least elastic curve (as hypothetically branch Dp'' of the curve DD' in Fig. 3) corresponding to the relatively higher class of beneficiaries of income, with relative greater revenues from consumers, can lead to the adoption of price $p''q''$ for the quantity Oq'' of the service offered. In this case it will be possible to have an excess of earnings on the corresponding cost that, in the hypothesis of the geometrical representation, may have dimension $rst'' = pvp'c$: in other words, be able to compensate for the loss of supply of qq' at price $p'q'$, and to cover its total cost.

Therefore, the differentiation in the supply prices may allow generally or for the time being, in relation to the intensity of public interest in the view of the governing class, to cover the total cost of production, by drawing from the $rstp''$ part of the revenue from consumers (spD , here expressed in Marshallian terms, that is to say, assuming the marginal utility of money remains constant) of the higher class of beneficiaries of income. This is done so as to create the possibility of a consumption

qq' in favour of the lower class of beneficiaries of income who, otherwise, would be excluded from the consumption of the public service.

Public interest, therefore – in other words the judgment on the maximum utility for the community – might want to *extend consumption* from q to q' , compatibly with the general or present condition of overall cover of the production cost, as the law of the supply of public service. The public price, in a context of *multiple* supply prices, does have exceptions. Take the case of the *unique* price (tariff) in public enterprises. This is the case of postal, telegraphic, etc., tariffs, that do not vary with the varying of the *quantity* of the service offered (distance) but vary with *type* (degree of rapidity, certainty or risk, etc., of the service).

These are cases of *generalisation* so relevant to the service that the offer is made at prices that do not take into account the *quantitative* specifications when there is individual demand (in relation for example to distance, as a homogeneous quantitative factor), provided that the overall cost of production is generally covered. The simplifications derived from proportionality of the price to the quantity of the service offered (distance in postal and telegraphic communications) is such as to influence the absolute level of the same cost, which becomes even lower, to the advantage of a greater number of consumers.

When the generalisation of demand for the service is not such (inter-municipal telephone service) as to make unification of tariffs (public prices) convenient for the service offered at “public” supply prices, then there normally is a differentiation in the prices. This is the typical case of the railway service.

We warned that the hypothesis of constant costs was used in the geometrical demonstration only with regard to a *formal simplification*, to easily identify the logic of multiple supply prices, in harmony with the condition of cover of the overall production cost for the service offered to consumers and the community.

However, the typical case we often refer to in terms of the public price as understood in these pages is that historically represented by the railway service, whose costs are normally decreasing. Railway tariffs, as an example of multiple prices, take into account the extension (distance) of the service in a quantitative sense, and of the type of service (travelling class, high or low speed for goods, and quality of goods: luxury goods, “poor” goods, etc.). The conditions that determine the exchange of space (convenience of inter-provincial, inter-regional and international exchanges) and the conditions (internal economies or cost laws) of the offer of the service make a policy of differential decreasing tariffs logical and necessary. In fact: *a*) even in practice, it is not demonstrated that the benefit of the service to consumers is proportional to the distance (both for travellers and for the transport of goods); *b*) in the average of management periods the railway service is not subject to costs that are constant but rather to decreasing unit costs. There are general expenses whose unitary charge decreases (amortization of works and plants, expenditure on travelling or office staff, etc.) with the intensification of the service. This logically justifies decreasing differential tariffs with increasing quantities of the service offered to users and indirectly a benefit to the entire community.

Examples of supply prices that may vary with the hypothesis of quasi-private or private-public price, in the sense in which we have discussed in the preceding pages, cannot be found in those cases where the State intervenes, for example in the field of:

a) credit, to facilitate the supply of credit in the interest of production of social income (in the sector of land, industrial or estate credit, etc.) with management of the price (interest rate) at market level or lower (contribution charged to the community and funded by general duties);

b) industry and mining through public companies or in the form of *mixed* enterprises or owned by the State, for the purpose of implementing State directives intended to achieve objectives of public interest, in the management of agencies that are run also by private concerns (current examples, among others, are those of State share participation in the Cogne Mines, Petroli Refinery, A.G.I.P., etc.).

In these cases and, generally when the public, state-controlled or mixed enterprise is formed to pursue objectives of public or mainly public utility, the prices that the consumers of the product or the users of the service pay in exchange for them, if not shaped by the finality of the quasi-private

price, are characteristic of the theoretical case of the *public price* or *tend* to be close to this typical means of public revenues.

C) Tax (as non-coercive payment)

Let's now examine how we pass from the case of public price to that of *tax*, in the sense of a payment for a *part* of the cost of production or of the supply of public services.

With regard to the classification of this institution, there have recently been introduced in Italy new doctrinarian guidelines. Some financial economy academics have *abolished* this definition of the classification of public revenues by making the corresponding real cases come under the abstract category of political prices, and by discussing public price and political price (alternating in some cases with the definition of tribute, which I have logically discarded).

I start with the identification of the existence of differential elements in the classification of, respectively, public prices and taxes. I do so, not through an attachment to traditional theory but because a more analytical consideration of the distinctive characteristics of tax differentiates it from public price as defined above.

I) In one of the best editions of Einaudi's *Corso [Course]* (Turin, "La Riforma Sociale [Social Reform]", 1926), in the classification of fiscal revenues that corresponds to Seligman's analytical theoretical differentiation, our economist defined tax as the *less than total cost* compensation paid by the taxpayers for a special and divisible service offered on their *demand*, but simultaneously for the satisfaction of an indivisible need of all members of the community. As these are (as in the case of *prices* examined up to now) *special and divisible* services offered to the individual on his *demand*, the author finds nothing to differentiate tax from public price.

Furthermore, Einaudi himself hastened to add that it was a particular and divisible service, but *simultaneously* destined to satisfy an indivisible need of all members of society and, therefore, offered at a *price lower than the total cost* of the exercise. "This" – he added – "is the characteristic that differentiates tax from public price". When we talk of public price – he added – we talk of a price paid to satisfy a perfectly divisible cost for an individual need, but one that the State intends, in the public interest, to satisfy by regulating public prices in a manner different from that in which private prices are regulated. However, as the cost of satisfying it is *completely divisible*, so the price must include *the whole cost*. On the other hand, when a *tax* is paid, the cost of satisfying the need is *no longer entirely* divisible among users: it is in part an indivisible cost. The most appropriate example offered was that of public education, which satisfies the divisible need (at a divisible cost) represented by the imparting of education and the achievement of professional qualifications; however it simultaneously satisfies the indivisible need (or at an indivisible cost) represented by the benefit of developing educated managing classes.

The divisible part of the cost, in this case, is covered by the tax while the indivisible part is covered through duties applied to all taxpayers, even if they do not require the service. As difficult as this differentiation might be in practice, its logical theoretical foundation is understood.

In the 1932 and 1940 editions, stripped of the part relying on variable positive legislation, the "Course" became a theoretical treatise (taking the title of *Principii di scienza delle finanze [Principles of the science of finance]*, G. Einaudi, Turin, 1940). In this work Einaudi – followed later by Fasiani – replaced the term "tax", previously illustrated, with that of *political price*, leaving "tax" as a function to indicate determined tributes that in the Italian positive order are grouped according to particular administrative systems.

It is probable that the new terminology had an influence in the meantime (between 1926 and 1932, the publishing dates of the editions of Einaudi's work) on the publication De Viti De Marco's *Principii di Economia finanziaria [Principles of financial economy]*, who was then a professor at the University in Rome.

Furthermore, in De Viti De Marco's "Principles" (Sampaolesi, Rome, 1928) the tax was referred to as a case of *public price*, provided that it was used to indicate the price of a public service. De Viti, however, made a distinction only between *special* and *general services*: for the former a price is paid which is called tax; for the latter a tax is paid.

De Viti De Marco's definition can be accepted as a generic distinction. In the context of special services, however, a *specific* distinction can be made. Rather than state that *in any case* the tax is the cost price (public price), it is possible to differentiate between the case in which this happens and the hypothetical cases (historical *trend*) where there are movements from the condition of *equality* in the total, between the tax and the cost of production of special services: a tax in the narrow sense.

De Viti De Marco admits that, in the case in which the tax is higher than the overall cost, the "excess" serves to cover the cost of *general* public services: the tax therefore takes on the characteristics of a tax. In the case where the tax *systematically* (and not only temporarily for the necessary adjustments between supply and demand) fails to meet the cost of production, it is necessary to admit that the *permanent exception* to equality between cost and overall cost of some services gives rise to a sort of financial figure (the tax, in fact, whose denomination is maintained in these pages to explain the real event of the same name), to be differentiated from the similar type represented by the public price in *the strict sense*. Public interest in this latter case is less pronounced and the State can limit itself to surrendering the monopoly profit other than for cover (with the public price) of the cost of production as a trend in the sense already specified.

In conclusion, the element represented by the *objective of public utility*, which was already relevant in the case of quasi-private price, is even more significant in the case of public price but it takes on an additional importance (higher grade) to the extent that it gives rise to an *indivisible* part of the cost in the case of tax. In that case the divisible part will be covered by payment of taxes; the indivisible part of the cost of given services (not covered by taxation, globally demanded from individuals who have requested the service) will be covered through taxes imposed on the majority of taxpayers.

The first definition of tax by Einaudi is the one that we can consider more obvious and rational, even in the current state of more analytical theory. This is all the more so because in 1940 this author meant political price as that characterised by a *more relevant public element* than that identified in public price. This concept has been expressed with regard to tax here. It is clear that this is purely an issue of terminology, not logic.

D) Mixture of non-fiscal taxes and taxes with the nature of tributes

The wantonness and impropriety of the legislative language, especially in the case of Italy, with the designation of "taxes" for tributes that are compulsorily collected to sustain indiscriminately the costs of services with indivisible benefits, has generated confusion (which persists in the juridical field) in the classification of these forms of public revenues.

The confusion has been complicated by cases where, in part, two logical extremes that are at the basis of these classifications recur: *a)* the specific private interest that *could* determine the request or demand for a service in the case of non-mixed tax, with a general tribute and a tax in the same payment; *b)* the cover of part of a specific cost for a service supplied, *also* in the interest of single members of the community, that is to say *in addition* to it being a benefit to the entire community.

I) A typical Italian case is that of the *stamp* "tax" (in legislative context denominated stamp duty after 1937). As a "non-fiscal" tax, in the sense we intended earlier, this could be separately the payment in relation to the demand of the service consisting of the public registration of transfers of wealth, for the purpose of: *a)* ascertaining the legal existence and the standard of the deed that represents the instrument of the circulation of wealth among subjects – investors and producers of new wealth; *b)* assigning the *definite date* to the deeds with regard to third parties; *c)* easily ensuring proof and executions of conventions.

However, the overall *quantum* of the payments for this service that might be demanded at the initiative of individual members and private groups of the community not only covers but greatly *exceeds* the *cost* of the registration service. This warns us of the *simultaneous* existence of a fiscal content in the so-called registration "tax", whose amount generically funds, with other general tributes, the indivisible cost of public services. The base criteria that logically explain duties or tributes on transfers will be illustrated later.

Meanwhile the existence is noted of these cases of taxes, as some authors define them, that are "mixed to duties", as general tributes, or "with elements of duties" coexistent with the same taxes.

The mixture and coexistence of forms of public revenues that persist even if, as it has been the case (since 1937), the denomination of this mode of collecting mainly fiscal revenues has changed. Indeed, turning the matter upside down, it is to be admitted that Italian registration duties contain an *element* of “non-fiscal taxes” or are “mixed” to this second form of non-fiscal mode of obtaining ordinary public revenues, in relation to a service that, if considered separately or as such (registration), could be demanded for the autonomous private evaluation and covered, in regard to the relative cost, at least in part by tax paid by the direct beneficiaries.

II) Analogous considerations apply for the *succession* “tax” (a *tax* since 1941). In addition, as we will see, to collect a part of wealth from estates left and inherited, in the occasion of their free transfer, for the purpose of assigning the income or revenue to sustain the indivisible costs of services for the general benefit of all members of the community, the State uses succession “taxes” to cover the cost of a service that could be demanded on the initiative of members of the community, for their utilitarian choice referred to the instrumentality of the service. It consists of: *a*) “protecting the transfer of inherited assets”; *b*) “registering and preserving the trace of the inherited passage of property”, guaranteeing, in an area that is often subject to controversy, “the safeguarding of the rights and the juridical succession of the property, from the deceased person to the heir” (Pugliese).

So this service of undoubted private as well as collective utility would require its supply or production at a *cost partially* charged to individuals who require through their own “choice” this same service. However, this analysis of the dual nature of the forms of revenues that are both fiscal and non-fiscal is not possible because of the mixture of the two modes of covering the cost of special or divisible and indivisible general services, in a single one. This reasoning could be repeated, after the denomination of succession duties, introduced for these tributes, as having in *themselves one part* of the nature of non-fiscal (“taxes”) revenues in the sense here illustrated.

E) Contributions (of specific betterment)

We continue with this criterion of the relationship between the cover of the cost of services and forms of revenues that can be rationally used by the State that offers the same services, to differentiate, in the view of the governing class, benefits for individuals and benefits for the community.

In dealing with private, quasi-private and public prices, and with non-fiscal taxes, the interest of individual members or groups of the community, has theoretically been linked to active demand, prompted by the utilitarian judgment of individuals (hedonists and producers), or to the “choice” of private individuals. This is a choice that acts as a guide for the governing class, for the purpose of covering all or in part the cost of the service by distributing it, with various criteria (of prices or payments) at the expense of: *a*) *direct* beneficiaries of the services; *b*) the community indirectly benefiting (normally general tributes).

With regard to betterment taxes, the element of *direct* utility or advantage of services is no longer linked to the active demand of individuals but ceases to be, as we have seen in the previous paragraph, a discriminating variable for the purposes of covering the cost of the same services.

Hypothetically and historically, the offer is made in a context of *obligatory consumption* at the expense of individuals, on the basis of “choices” or a decision on the part of the State (or other public body); and the *indirect* benefit is measured or presumed with criteria that are exclusively subject to the initiative of (public) subjects of the financial activity.

There is a logical identification of the relationship between: *a*) the importance or relevance of private interest (measured as direct, presumed or determined benefit through public criteria) and *β*) a quota of the cost of production of the services that benefit simultaneously in a different way private members and groups of the community. The territorial community, overall, is no longer dictated by theoretical intent or an hypothesis of what might be the logical relationship between revenues and expenditure, when correlated. However, in this case, the hypothesis serves to immediately explain reality.

In fact, for example, it is possible to draw from real cases to find a relationship between cost of production of the service and destination to cover *part* of this cost of a revenue collected from members of the community *indirectly* advantaged by it: in other words, those who have expressed a

utilitarian judgment with active demand but who have also felt the obligation to consume the same service.

These cases are supplied by: *a*) art. 7 of Legislative Decree no. 2000 of November 1938, that, with regard to betterment taxes for works carried out by the State or with its participation, among other things admits that “the sum of all contributions due for the same work cannot exceed 30 per cent of the cost of the same work”; *b*) art. 238 of the Consolidation Act of 1931 on local finance that, among other things, indicates that “the sum to be divided among all proprietors affected by a specific betterment tax cannot exceed, in any case, thirty per cent of the expenditure sustained by the municipality or province for the execution of the work”, etc.

And from here arises the actual phenomenon supporting the following hypothetical correlation. That is to say, as we gradually move from modes of procuring revenues [from private to quasi-private, to public price; from the tax (with non-fiscal content) to the (specific) betterment contribution], so the general benefit or utility for the community is evaluated as growing by the State and smaller local governments; II) and the quota of expenditure or overall cost of services charged to members (or private groups) of the community directly (active private demand) and indirectly (obligatory consumption with divisible benefit) who benefit, individually or as a group, from the services provided with the above mentioned forms of revenue, *decreases gradually*.

The betterment tax indicates the hypothetical introduction (with immediate historical validation) of the *obligation* of consumption of public services, with the simultaneous introduction of the *minimum* limit or of the minimal (overall) quote of *cost* of the service charged to members of the community who derive an indirect but divisible and empirically measurable benefit.

It should be admitted that in respect of the (non-fiscal) tax the quote should normally be *over* 30 per cent of the cost of the services. However, this may not *instantly* correspond to a real case, and it may only theoretically be taken as characteristic of the (non-fiscal) tax from the point of view of the *quantum* of overall cost charged to those who, through their active demand, enable its direct, private and divisible, utilitarian identification. Considering long periods or historical *trends*, the real phenomenon may be interpreted by stating that the quote of overall cost of production of the service, for which the global payment of the tax is demanded, is *greater* than the quote of cost that is covered with (specific) betterment taxes or that derives from a particular State initiative of public works. Indeed, theoretically the interest, utility or general advantage for the community would be measured by the *greater prominence* (degree) of the cover of the cost charged to the community as such (and empirically in the Italian legislative example, by 70 per cent of the cost of the work), with a passage to services whose consumption is obligatory, with a measurable direct advantage and whose cost is covered in part by (betterment) taxes and for the rest with general tributes charged to the entire community.

There are criteria that indicate a theoretical trend law, quite suitable to the interpretation of the real phenomenon. That is to say, as the interest or benefit, evaluated by the governing class for the subjects (State, municipality, etc.) of the financial activity *gradually prevails*; at the same time, the part of the indivisible cost *gradually tends to increase*, and the part of the divisible cost of public services tends to *decrease*.

The reference to positive legislation removes any idleness (in the sense already indicated by Pantaleoni, in the relationship between hypotheses and theories on the one hand, and facts to be explained on the other) from these logical distinctions, and helps to make its fruitfulness understood.

Having said this, I define the specific betterment tax as the obligatory compensation, paid to the public body on the occasion of a work completed by it for the public utility, but from which the proprietors of real estate adjacent to the public work derive particular and indirect benefit¹²⁶.

With regard to the *juridical aspect*, the betterment tax represents an inverse entity to that of the compulsory purchase indemnity as the contributions include the obligation of the individual to reimburse the public body for a *part of the expenditure* or cost that has benefited him. In the second

¹²⁶ The *generic* betterment levy is due in relation to the increase in value, especially in areas under development, that can be attributed to the *totality* of *public works* carried out in the municipality or the organic totality of works (even transformed works) completed by the State. This has the nature of a levy, as well as an instrument of *financial policy*, in the context of public bodies' building policy.

case it represents the obligation of the public body to reimburse individuals for damage caused to them.

When De Viti De Marco's *Principii* [Principles] (1928) were published, it was possible to understand that he, through the *special tax* theory (which exists, in his view, when the State takes responsibility for the production of a service that primarily or exclusively benefits a social group and charges primarily and exclusively this group the tribute necessary to meet its relative cost), thought the so-called betterment tax was a *typical case* of the special tax.

Keeping in mind, in the context of special tributes, the concepts of Jannaccone, Seligman, Sax, Dalla Volta, C.F. Ferraris, Tangorra, etc., I thought that De Viti's simplification modified the theoretical premises on which others had differentiated the betterment tax from special taxes [that someone (Dalla Volta) had questionably integrated into taxes]. In 1929 I returned to the argument of classification of those institutions that recur as means of revenues for the State and municipalities¹²⁷. Later, in G. Borgatta's "Appunti di Scienza delle finanze" [Notes on the science of finance]" (1933), the betterment tax was represented as "the most typical institution of special tributes", no different from other cases that may be included in the relative simplification of the institution of the special tax. Other authors, such as Cassola and Bertolini, in 1932 and in 1935, also returned to this subject, *in a specific and professional way*. I do not make reference to the subsequent treatises that do not affect the logical question.

De Viti De Marco does not believe that there is divisibility of service in *special tributes* in terms of sale units; the benefit of service is, however, *divisible* in the case of the betterment tax. Borgatta also recognises this. He does, however, believe the benefit not to be *identifiable*, in the sense that it necessarily extends to components of a group (in this case proprietors of buildings included in a radius of influence of the public work). From that point of view this criterion is convincing but not decisive. Indeed, such a circumstance justifies the obligation of payment of the contribution and therefore the fiscal coercion, which is a dominant characteristic of the tax. The contribution, however, is distinctly different, because of the *measurability* of the benefit, in other words, the "betterment". In my view, this tribute presents characteristics such as to be considered, in spite of recent diverse classifications, according to the vision initially put forward by Seligman, and that is to say, *as a category in itself, aligned with special taxes*.

Let's recognise the contribution of taxes. The first is a contribution from private parties to which correspond a *partially divisible service*, provided by the public body, a service whose indirect benefit is measurable, even if by approximation, for each individual real estate proprietor who has benefited from it. Similarly to the contribution, the tax is paid as a *part* of the *cost* of a divisible service, even when the difference in relative degree is taken into account.

However, while the field of application of taxes is general and not limited, as they correspond to services of every type offered by the State, in the case of contributions – and this is the second special characteristic of the contribution – this is delimited, *localised*; so that in this way the service offered by the public body can only be an improvement to real assets (real estate) by the public work.

From this we derive a third differentiation: in the case of tax, *individuals, as such*, make a demand and pay to obtain a service, while the betterment tax is generally charged to the individual *as a member of a category of people*. That is to say, in this case there must always be a taxed area on which the tribute is charged for the entire cost and then subdivided according to an overall limited distribution plan (for example, 30 per cent of the *cost*). As we are dealing with a public work of improvement, it is natural that it is extended to a part of territory and therefore that it affects buildings of several proprietors: in the meantime these proprietors feel an indirect benefit that is divisible because one own's *real estate and buildings* are improved by it. This occurs where the individuals who pay a tax can obtain a benefit, both personal and real, over different elements, such as individual assets or other attributes of the person, that can benefit from it, as there is no relationship with the specific real assets and property.

¹²⁷ E. D'ALBERGO *Il contributo di miglioria e le imposte speciali nella scienza delle finanze e nel diritto finanziario italiano* [The betterment levy and special levies in the science of finance and Italian financial law], S. E. M., Catania, 1929.

A fourth difference between the two forms of revenue is that taxes are paid several times, as many times as the service *is demanded* of the public body, while the betterment tax is *paid only once*, for an amount globally determined, following the completion of a public work. There are cases where taxes are only paid once, but this does not affect this differentiation. And if, on the other hand, the contributions are paid in instalments over a long period of time, to facilitate their practical application, nevertheless the payment is capitalised in a single overall sum, to be generally paid once or, exceptionally, in several instalments.

In fifth place, the contribution and the tax are paid to cover *one part of the cost* of a public work completed in the interest of the community; there is therefore a part of expenditure that is attributed to the community, and it is therefore indivisible. However, while the service offered in compensation of a *tax* may mean that the individual interest of private entities may prevail on the interest of the community or, as an hypothesis more frequently verifiable, it cannot reach the degree of prevalence in the case of the contribution even if the public interest prevails; conversely, in the case of works carried out by the public body and for which it imposes a contribution on private individuals, it is the *interest of the majority* that prevails and the benefit to individuals is indirect and secondary, more than in the case of services demanded by private individuals or members of the community and corresponding to taxes.

Finally, a contribution is in any case a *compulsory* payment while tax is due following the *active demand* of a service. In the case of the contribution, the benefit is generally not requested by private individuals but derives from a social necessity, from considerations of public utility: therefore the compensation demanded of those whose property is improved is necessarily compulsory in the same way as the consumption of a public service.

Therefore a characteristic that is *common to taxes* is the compulsoriness of the consumption of the service and of the payment of the contribution: for this reason the contribution represents the bridge of passage from a system of public price and of tax to that of tax. However, unlike the case with the tax, the contribution is paid for the partially divisible service, as this is offered *also* to a given social group, whose members indirectly benefit individually from a measurable advantage; that is to say, where the tax is implemented for general, indivisible services offered to the community as such and normally overall undifferentiated.

Another characteristic that differentiates the two forms of financial revenues is the fact that the field of *action* of the tax *does not have limitations*, in the sense that, as it is universal, it applies to all taxpayers and reverberates at the same time its indirect benefits on *all* members of the community in the territory of the State, the province or municipality; on the other hand the betterment tax, that by our previous definition is paid-for services that bring an improvement to real estate property, is necessarily applied to a limited area of the territory.

[I refer readers to juridical treatises (financial law) for the Italian legislative directives relating to the betterment tax.]

F) General taxes.

In passing from tax to general tax, the betterment tax, in itself, immediately precedes special taxes that, in the later institutions of the general tax, assume the relevant logical characteristics with greater approximation. When some consider the betterment tax as a typical case of a special tax, it is necessary to remember the differentiation between the two types of tributes.

A characteristic of the contribution that – as we have seen – makes it very similar, on the one hand, to a tax is that individual proprietors of assets receive an indirect but specific benefit, from the execution of a public work, that is *measurable* for each individual; in this way taxpayers individually pay in proportion to the benefit (an increase in the value) that their own assets have experienced following the completion of the work executed for the general utility of the community. On the other hand, in the case of the special tax, the relationship between service and counter-service takes place between the public body and the group as a whole; this is the reason why the benefit is *differentiated only for the group*, while the individual components of the group perceive the benefit only in an *indistinct* way: the tribute, in this case, is generally commensurate to individual *contributory ability*.

Special taxes, that have already been kept separate from the betterment tax for sufficient reasons of principle, must be differentiated by taxes and (general) taxes because of their peculiar characteristics.

a) A characteristic that makes a special tax similar to a tax is represented by the presumption of a *benefit* in the public service in the sense that in the tax a direct exchange *for each individual* takes place between the services for which they have paid a (*lower than the total cost*) compensation and the specific divisible service offered by the public body against their demand. On the other hand, with a special tax there is the obligatory consumption of a service offered by the public body on its own initiative for the main benefit of a determined category or group of taxpayers who are generally responsible for *all* (or part of) the *cost* of the service they *all* consume.

b) The affinity between the two forms of revenue is maintained from another point of view. That is to say, in the same way in which the user as individual pays the tax because he obtains a service from the public body on request, so only those who have in some way benefited from the advantage deriving from a service offered to the group as a whole are requested to pay by the taxing body that presumes the benefit of these same advantages. In other words, special taxes are charged to groups of taxpayers for services to a *small community*. Uniquely as a member of the *same community* and not as an individual demanding services, therefore, the taxpayer derives an immediate and non-immediate utility.

c) A situation, in which the nature of the special tax is so close to that of the general (tax) as to be identified with it, is when, in both cases, the public body produces a service without waiting for the individual or group demand nor is it concerned, once it has supplied it, in both cases, with the greater or lesser extent in which the members of the group of the whole community will benefit from it.

d) Another characteristic that is common to the general and the special tax in consequence is the *compulsoriness of the payment* of the tribute in the two cases, whether it is imposed on members of the specific social category or on the entire community.

e) However – and this is an important difference – in the case of special taxes the tribute is paid because individuals belong to a group or a *category* that, as such, enjoys a specific benefit: in this way the special tax is not paid if there is no service offered for the benefit of a private group by the body which applies it. On the other hand, in the case of general taxes the tribute is paid also by those who do not benefit, in a differentiated and significant way, by a given public service and the revenues of the taxes are added together to sustain the overall cost of public services, considered in their totality. It derives from this that special tributes are not normally added up with others to provide for the needs of the community as such but are earmarked to provide *mainly* specific requirements of a category or a social group¹²⁸.

¹²⁸ Examples of special levies: 1) it is a special levy that is charged by Chambers of Commerce (*chamber levy*). The objects of the levy are the commercial and industrial or agricultural incomes; this is paid by the traders, industrialists, shipping captains, farmers, etc., registered with the same Chambers of Commerce.

The revenues from the levy, together with the tributes on temporary and itinerant trade and the revenues of the public bodies themselves, are assigned to the service of protection of the interests of the members who, as such, represent a social category with particular requirements compared to the rest of the community. Needs, indeed, that Chambers of Commerce can in part satisfy.

2) With article no. 1175 of the Consolidation Act for local finance of 14-9-1931, the inappropriately known “circulation tax for vehicles at animal traction” and the “supplementary contribution for road use” were implemented. These were due by organisations and companies that, in connection with the carrying out of an industry or commerce, caused an exceptional wear and tear on roads with the transit of vehicles “with mechanical or animal traction”. In these cases too it is possible to identify the example of a special levy on groups or categories that *particularly* benefit from the public service of viability, which *also* meets general needs. The same nature of special levy can be identified in the “single road tax” established by Royal Legislative Decree No. 1121 of 29-7-1938, which replaced the circulation “taxes” for trucks and trailers and the road use “contribution”.

3) Finance academics, vis-à-vis trade organisations in Italy, have examined the nature of *trade union contributions*, and some have recognised the characteristics of special levies in them.

IV.

GENERAL TAXES AND THEIR CLASSIFICATION

In passing from the institution of quasi-private price to those of, respectively, public price, tax, betterment tax and special taxes, we have seen how the private interest, of the individual or group, has become progressively less important and how the element of undifferentiated *public interest* has become *gradually* more important.

The case in which the *cost* of public services is indivisible by definition, without the systematic identification of groups as being particularly privileged by some services, is that of the *general* tax, that is to say, the tax that is charged to all taxpayers who are in the conditions set out by the individual laws.

The general tax is the tribute that is of most interest from the theoretical point of view because it presents the greatest number of problems, some of them still unsolved. From a rational point of view, it can still be said that the problem of the “optimum” criterion of distribution, among taxpayers, of the general tax to sustain with it the *overall indivisible cost* of public services, offered by the State for the *normally* indiscriminate benefit of the community as such, to which the State governing class imposes the consumption of the same services, is still unresolved. As it can be seen, this is the central issue, to the solution of which financial theory has contributed by now for more than two centuries. As it will be seen later, the theoretical conclusions do not fully satisfy the solution to the real problem, and the positive norms with which the legislators solve it are, for the most part, to be considered empirical or approximations of some scientific models of distribution of the general tax for the meeting the cost of indivisible services *generally*.

Before considering this problem and other significant issues of financial theory, it is necessary to proceed further in the fiscal *classification*.

There is no need to insist further on the differentiation between *general* and *special* taxes, as this should have been made apparent by preceding paragraphs, if account has been taken of the most rational and scientific meaning of the terms used. From a mainly *administrative* point of view, however, those taxes are considered general that affect all categories of some types of economic-juridical events. These are, for example, taxes that affect all types of taxpayer's *assets* (estate and securities); or all *incomes* from them or, generally, all consumption, as the Italian tax on “income”. On the other hand those taxes are *special* or particular (or dividend) that are charged to some assets (for example estate only) or income from a given source (land, buildings) or specific items of consumption (affected by building taxes, duties, etc.).

Others, following their own theory, do not recognise a special levy in trade union contributions. For this to be so, they maintain, it would be necessary that, of the totality of members in trade unions, one part of them is charged a special levy in return for a specific benefit. However, even at the initial stage, as implemented by the previous regime, it was possible to find some element of the special levy in trade union contributions. It is true that the obligation of the payment of contributions was generalised to such an extent that all categories of producers, in the widest sense, were passive subjects in Italy. It is also true, however, that they, and only they, as producers, derived a particular benefit, composed mainly of the protection of the interests of individual classes. This can be considered as the compensation obtained by the public body who received, as in a special balance sheet, the revenue from the contributions. For example, those receiving interests on State bonds obtain an income that is defined as produced (rather than enjoyed). However, as they did not belong as such to any trade union category, they had no obligation to pay the relative contributions: they did not, however, have the right to any trade union service, an exclusion that does not happen in the case of proper general services for the benefit of the whole community. And, if we don't want to classify the contribution as a special State levy, since the law recognises that trade unions have the power to demand tributes from their members, we cannot but consider it as a special levy applied by an institutional public law body.

For brevity, I have omitted other examples of special levies that can be identified in current and past legislation of Italian finance.

A) Direct and indirect taxes.

A classification that has a certain economic and juridical relevance is the one that differentiates between *direct* and *indirect* taxes from various points of view.

1) From the point of view of administrative order *direct* taxes are those that are established and collected through the formation of a taxpayers' *list*. Direct taxes on income from land, buildings, commercial (professional or clerical) activity are a typical case of this. On the other hand, the case of occasional exchanges, consumption of assets and goods are excluded, as it is not possible to fix "a priori" a list of those who transfer wealth or consume such goods in a discontinuous way: these are taxes that are therefore referred to as indirect. This is not, however, a rigorous differentiation. In practice there are consumptions of durable goods and services that give rise to so-called sumptuary taxes (on the rental value of an accommodation, on hired help, on cars, etc.) with regard to which it is impossible – as happens in reality – to proceed to the formation of a list of taxpayers.

2) A second differentiation is based on the theoretical concept of the *transferability* of the tax. This theory will be analysed in depth in the following chapters: in the meantime it is possible to anticipate the current definition by which there is a *shifting* of a tribute, when the taxpayer as permitted by the law (*de jure*) manages, through a price variation, to make all or part of the burden of the tribute chargeable to a third party with whom he is in a relationship of exchange (of goods or services). The *de facto* taxpayer in that case is the third party, as *economically* affected by the tribute. The *direct* tax is the one that *cannot* be transferred, the one that is charged to the taxpayer initially indicated by the law that introduces the tribute or sets its rate. *Indirect* tax is the one that can be transferred to third parties.

This differentiation gives rise to two comments: *a)* first of all non-transferable taxes do not exist, according to the widest and most rational view of the process. Another issue is the consolidation or amortization that will be discussed later, that furthermore some theorists consider as a case of *regressive shifting*, if shifting is intended not only as the one that can take place in the relationships between those who offer and those who demand goods or services (*forward*) affected by a given tax, but also as the one that takes place through variations of relationships of exchange *different* from those in which the object is affected by a given tax. When, for example, it is stated that the tax on State stipends and pensions is not transferable, it is meant that the employee cannot ask the State for an increase in the stipend or pension, when this has increased the tax, or that he cannot obtain such an increase even if he were to ask. It is, however, possible, in certain given conditions, for the employee to: obtain a reduction in the rent of accommodation or a reduction in the cost of clothing, etc., and transfer (*backward* or regressively) the tax. The same can be said of personal taxes and in terms of those relating to cases of income that, as will be seen in specific circumstances, are totally or in part not transferable (*forward*).

The definition is, however, particularly questionable when we consider, as will be seen later, that all taxes modify the equilibrium of exchange relationship on the market.

b) The most significant objection is represented by the fact that, even if the concepts in the classics or the view by Pantaleoni of shifting was accepted and we relied on real events, the *same taxes*, with the variation of the economic circumstances and of the politico-juridical constraints, would become, at different times, transferable or otherwise and therefore, direct or indirect, without a constant *fundamentum divisionis*.

3) This is identifiable as an immanent but rather conventional criterion in the distinction that compares *direct* to *indirect* taxes on the basis of the immediacy or otherwise with which the contributory ability (a concept that I will illustrate later) of the individuals is manifested to the taxing public body.

When economic-juridical events, canonised in fiscal laws as presumptions of the imposition, *immediately* (or directly) manifest a contributory ability, then the tax that comes into effect is defined as *direct*. These are events such as the ownership of an asset, the perception of an income from a continuous activity, immediate and direct indices of the existence of an accumulated wealth or a wealth (income) being formed. When, on the other hand, they are events that can be interpreted as indirect or mediated indices of contributory ability, such as the initiation of a succession, a buying and

selling transaction, the consumption of an asset, etc., the taxes charged to the transfer and the consumption are defined as indirect.

This distinction, however, is not exhaustive. The tax on transfers (indirect index) upon payment or for free is as easily *comparable* to a direct tax on the *assets* object of the buying and selling transaction or of inheritance. The income itself (perceived or produced as example of the direct or immediate manifestation of the contributory ability) is not always an index sufficient to ascertain contributory ability: and sometimes it is integrated by *indirect* indices for the verification of the contributory ability for the purposes of the application of indirect taxes. This is the case, for example, of the supplementary tax on income and the family tax. These are direct taxes par excellence, based on taxable income (overall produced and available income) ascertained, for *supplementary* purposes, by using indices of *consumption* of income, that is to say, *indirect* manifestations of a contributory ability that, according to the distinction here clarified, should be met only in the context of indirect imposition.

In spite of the fact that this is not exactly determined, however, in its differential extremes, this third criterion of differentiation of direct from indirect taxes finds frequent application in the illustration of positive legislation.

B) Real and personal taxes

Another classification of taxes that has a significant theoretical importance and that finds various applications in financial legislation is that which differentiates taxes into *real* and *personal* taxes.

Those taxes are *real* that are charged to wealth or income in themselves at the point of production, transfer or consumption, leaving aside overall economic conditions, familiar conditions (number of dependents, civil status and family status), risks to be considered (invalidity, old age) by the *person* who produces or receives the income, acquires wealth or consumes it. Those *taxes* are *personal taxes*, or present some elements of “personality”, that take into account the conditions mentioned and other conditions regarding the *physical person* of the taxpayer.

The following are therefore characteristics of the *reality* of the tax: 1) the real tax affects income at source and follows it through the people who subsequently become proprietors; 2) it affects the income or wealth in the territory of the State or of lesser bodies in which it is produced or in the State territory where the assets are or are transferred into; 3) it can rationally be applied through particular or dividend tributes on the income from given sources¹²⁹.

Characteristics of the *personality* of the imposition would primarily be the following:

1) In the case of direct taxes on income and on assets, the taxable sum is normally constituted by the *combination* of incomes and assets; 2) this condition is rationally *necessary* (as will be explained later) so that the *progressivity* of rates can be applied; 3) the consideration of a minimum for subsistence or for meeting “normal life requirements” of the same taxpayers; 4) the *differentiation* of incomes, in the sense of less “harsh” taxation – also through the deduction of a fixed amount to meet normal life requirements – of incomes due to work (professional, business or clerical) of the physical person, with regard to taxation of incomes “based” on assets, whose return is for the great part independent from the life of the physical person (land, buildings, securities); 5) in the case of personal taxation on incomes, the law permits deduction (from taxable income) of all *passive interests* (on taxpayer’s debts) that *affect* the *availability* of the income benefiting the physical person. [On the other hand, on the prevalently real taxation, for example, only passive interests (and annuities) for debts are deducted only if they are pertinent to the productive process through which a certain income has been produced]. In other words, in the *personal* taxation, the aim is to ascertain the *disposable* income (after the deduction of all expenses, liabilities and personal obligations of a person; 6) the deduction, for the purposes of ascertaining taxable income, of premiums for the insurance of the life

¹²⁹ These distinctive elements, elaborated by the science of finance, are not to be confused with the juridical element represented by a *real* guarantee. With this (or by means of privileges) the State guarantees its own right of credit towards the taxpayer, but this does not however mean that the right to levy is a *real* right on things.

of the physical person and allowances for people who are dependent by law on the taxpayer (right to food).

C) Proportional and progressive taxes

Theoretical problems of distribution of taxes will be discussed later, dealing with the differentiation between *proportional* and *progressive* taxes; in that context the characteristics of the imposition, respectively personal and real, will be further illustrated.

For now let's say that this classification differentiates as follows: *a) proportional* are the taxes whose rate (percentage) is maintained constant as the income received (produced) by the same taxpayer or different taxpayers or the wealth owned by them (accumulation of assets) or achieved (through buying and selling transactions or succession) gradually increase; *b) progressive* are the taxes whose rate varies (increases) as the income or wealth increases; the tax will therefore be *more* than proportional as the taxable income increases. The logical basis of this classification will be analysed in the further developments of these lessons.

In the meantime, I have insisted much on these classifications because they help to explain the logical phenomenon of the events of public finance.

Starting with scientific publications about classifications of financial theory, at a young age I recalled A. Roncali's thought (published in the "Riforma Sociale" [Social reform] in April 1896):

"The classification of public revenues, from the logical if not an historical point of view, is the condition before the analysis, in fact the very analysis in its perceptible form.

In fact it appears that the study of the diverse forms through which the State draws and participates in the national income is far more important than many other metaphysical devices that financiers and economists indulge in. It also appears that this study has not only theoretical but also practical importance because, in the end, the eternal question to be resolved in finance is always that of the sufficiency of public revenues and the right distribution of the burden".

If these concepts are interpreted in the light of the *rational* vision that precedes in the introductory chapters, logical links will be noted between the classification of the modes through which the State procures revenues to meet expenditure and the analysis of useful subjective and objective effects, of the "choices" of individual members or private groups of the community and of the public authority, especially in the distribution of the cost of indivisible public services to meet ordinary and extraordinary public needs. The following pages address the numerous relative theoretical problems that derive from this.

CHAPTER III

ABOUT THE SUBJECTIVE DISTRIBUTION CRITERIA (“MODES”) OF THE COST OF INDIVISIBLE PUBLIC SERVICES

I.

HYPOTHETICAL SWITCHING OF THE SUBJECT OF HEDONISTIC EVALUATIONS FROM SINGLE MEMBERS OF THE COMMUNITY TO THE GOVERNING CLASS OF THE SAME COMMUNITY

While remaining logically faithful to the definition of this science that I have given, a definition that places the study of the modes of distribution of the cost of public services as the object of this science first of all, I now move on to analyse in further depth a fundamental characteristic of the general tax, when it refers to the overall wealth of physical people.

In other words, and in connection with the preceding chapter, I will try to account for the logical genesis of the progressive tax, in relation to the economic aspect analysed here. This aspect contributes, along with others which will be mentioned briefly, to the explanation of the transition from proportional to progressive tax.

According to some authors, this type of problem is not actually a task for the economist but it is rather a generically “political” or, possibly, historical issue. This is on the basis that an expert in economic science, which has as its object the events of financial economy, has nothing to say about this. There would be no need for this chapter if we followed the still applied traditional approach that resists theories and principles attempting to account for the mode of being of equality and justice, as they are viewed by politicians, in the field of general fiscal taxation which compare subjects (such as physical persons) who have different means or overall wealth (income or assets) to contribute to the expenditure of the public body. The same prejudice would apply to proportional tax.

On the other hand, I believe that the sceptical attitude of those who declare this science’s helplessness in this area is due to an inadequate view of the competence or method of this science – as I have defined them in the *Introduction* – or to a lack of or inappropriate choice of explicative hypotheses of the financial phenomenon being studied or due to the fact of the coexistence of proportional and progressive taxes in fiscal systems. Indeed the traditional view of subjective principles (sacrifice of utility of wealth), on the basis of which attempts have been made to explain an aspect of the rational emergence of proportional and progressive taxes, has eventually become sterile in reaching a conclusion with regard to the existence of political *discretion* in this field, without a minimal logical view of the problem.

The failure of some hypotheses, with regard, too, to the evolution of events, and methodological and logical confusion, are also apparent in the approach of masters of this science and, in particular, of well-known Italian academics.

I) An *inadequacy of hypotheses* is noted, first of all, in many studies in finance; with a greater specification of the terminology used, it could be said that it is a matter of an inadequate choice in the hypotheses used to explain events.

Those readers who have studied closely the *Introduction* to this course will now find a new reason to justify the great insistence on the hypothetical view of the construction of this science: in other words, in its use as a gnoseologic instrument, or an instrument of knowledge. The explicative power of the hypothesis is that which allows us, now, to detach ourselves from the position of many academics who have reached the conclusion that any explanation of the progressive tax vis-à-vis the proportional and regressive ones is irrelevant in this field of research.

It is very true that the hypothesis has a subjective and intuitive nature and that it varies from academic to academic. This is so because the mental activity of the scientist when he attempts to explain the reason of the phenomenon or to account for its manifestations (while still analysing a single aspect, as we do in these lessons) is different in every case.

For this reason, as I have specified in the *Introduction*, there are more or less fruitful hypotheses. This expression (fruitful) is an expression that physics (for example Planck) has adopted to qualify hypotheses, more than to differentiate them into “true” and “false”. These are hypotheses that, when they are greatly in accordance with events, lead to the formulation of scientific laws, or to principles such as those that will be discussed in the next few pages.

In other words, the traditional sceptic, especially the type prevalent in Italy, with regard to the logical possibility of treating the problem of the progressive tax, draws from: 1) the lingering of the thought exclusively in the context of atomistic hypotheses: in other words, those who consider arbiters of the sacrifice or the utility sacrificed in the correspondence of taxes, be they general and personal, the single individuals themselves; 2) pretending to necessarily carry out *objective* calculations of measurement and comparison of the utility of the revenues collected in the form of tributes to proceed to the formulation of theory in this field.

In the explanation of fiscal revenues, however, we have seen how the calculation of the convenience of their collection is transferred from individuals to the governing class. The individualistic problem becomes a “mass” problem and requires adequate hypotheses for its explanation: that is to say, hypotheses that make us think by transferring the evaluation of the utility sacrificed by the fiscal event from individuals (atomistic view) to the governing class (macroscopic view of the mass problem). As Pareto – who we still follow for new scientific explanations¹³⁰ – stated, the governing class is the arbiter of the utilitarian evaluations that regard the individual making up the communities in which they live.

In pure economy, the individual has always been considered as the main judge and arbiter in a hedonistic context. In financial economy, which deals with *mass* problems with a compulsory solution, such as for example that of the equality in terms of contribution (in objective or monetary terms and in subjective terms or in terms of sacrificed utility), if “we want to take this task (that of arbiter) from him (the individual) we must find someone else to whom we can assign it” (Pareto).

Pantaleoni had already expressed a view on this logico-hypothetical order (*Cenni sui massimi edonistici individuali e collettivi [Notions of individual and collective hedonistic maxima]*) by admitting the logical legitimacy of carrying out hedonistic calculations *for* other people on the basis of what is known of human psychology (in the case of a child, for example, *for* whom parents and teachers make choices). It is a matter of representing the evaluations of others and, in the social or collective or mass problem, of representing the utilitarian evaluations of the members of the community typically considered (as we will see)¹³¹.

However, as I have already mentioned, since 1932 I considered (E. D'ALBERGO: *Intorno al concetto di costo della attività finanziaria [On the concept of cost of financial activity]* op. cit.) Paretian's view more adequate to explain the financial phenomenon and the institutions used by the State governing class. I return to this also for the explanation of the mode of distributing tributes even though Pareto did not use it for this specific scientific purpose.

In conclusion, a first logical innovation that we need to accept is represented by the judgment of the utilities of wealth owned and distributed, which in the fields of pure economy and of *non-taxation* public finance economy is hypothesised as being exclusively related to individuals. In the field of financial economy that explains taxation, however, this judgment, *for atomistic rather than*

¹³⁰ I must warn you that this reference to the hypothetical Paretian vision does not signify acceptance of the considerations of the economist and sociologist in the field of public finance and, in particular, of the progressive levy.

I am only interested in remembering, with regard to what we observe below in respect of the distribution of levies in a proportional and progressive manner (or regressive and degressive, in the meaning clarified further on), what was the treatment of the category of hedonistic utility and, more generally and in abstract, of the subjective category of subjective utility, or ophelimity, of individuals and groups of members of the community, in explaining collective or mass phenomena, whose solution is dominated by the decision of the governing class.

¹³¹ See the article by C. Cosciani published in the “*Rivista Internazionale di Scienze Sociali [International journal of social sciences]*”, 1936, with regard to the argued application in finance of Pantaleoni's concept of the State as a “guardian” who aims to ensure his wards reach a position of maximum satisfaction, which documented it with reference to all of Pantaleoni's works.

interpretative hypotheses, can move away from the individual members to the State governing class. In explaining the genesis of collection and expenditure of *a part* of wealth on the part of the State we have recalled the concept of (maximum) utility for the community. We will still need to make reference to hedonistic calculations that the governing class probably and most likely has carried out on behalf of the community, in judging the equality of contributions, for example in terms of progressive general and personal taxation, as opposed to proportional means.

Remaining in the individualistic or atomistic hypothesis – that the utilitarian judgment is the competence of the individual, even in the *context* of phenomena that explain financial economy (collections and compulsory consumptions) – we should remember the criticisms that suggest that the explanations we are abundantly involved with in these pages are in fact irrelevant to this science.

The individualistic hypothesis was abandoned by Pantaleoni and by Pareto, both masters in methodology and gnoseology, when they respectively conceived, without leaving the field of economic theory, as we have already mentioned, collective models of hedonistic maximum points and maximum utility points for (and of) the community. Pareto reached this model, as I mentioned in the *Introduction*, after having established that “the utilities of the various individuals are heterogeneous quantities, and that a sum of such quantities does not make any sense; it does not exist and cannot be considered. If we want a sum that can be related to the utilities of the various individuals, it is necessary first of all to find a way of deriving these from homogeneous quantities, that can be added up” (N. 2127, volume III, *Sociologia [Sociology]*). And the maximum of utility *for* the community is determined “independently of any comparison between the ophelimities of diverse individuals” (N. 2130).

Pareto assigns to the “public authority” the task of “necessarily comparing – without searching for specific criteria – the various utilities”. “In essence this (authority) roughly carries out the operation that pure economy carries out with precision, and homogenises heterogeneous quantities, through some coefficients” (N. 2131).

I will not insist further on this model that, in these lessons, has found application in comparing: *a*) the field in which the utilitarian choices and evaluations of individuals determine the mode and *quantum* of revenues of public bodies; *b*) with the field in which coercion follows, with regard to consumption of public services and of fiscal revenues, without *direct* involvement of the taxpayers in the solution of the problem.

Pareto illustrated his criteria for the explanation of mass phenomena or events, not believing that his logical position was irrelevant to economic science; he did, however, write about it in the “Economist Journal” (1913) by making significant references to *Sociologia [Sociology]*.

As far as I know, no one has denied scientific content to the attempt to explain the utilitarian calculations that the State or the public authority carry out *for* the community precisely in the extremely subjective field of hypothesised variations of ophelimity of individuals and groups of members of the community. Generally speaking, Pareto and the author of these finance lessons have not sceptically given up, declaring the impotence of economic science in explaining a normal event of State action, as Einaudi would suggest.

It is really not clear why the introduction of the variable of subjective utility of wealth cannot be analysed theoretically in the explanation of the fiscal event of proportional, regressive and progressive taxation. That is to say, it is sufficient to adjust the hypotheses and not insist exclusively on those with an individualistic character, but to use others that, as I have said later, take into account the sociality of subjects or individuals. These should not be considered only or exclusively as “stranded Crusoes on a desert island” but as individuals recognisable from the real life of social complexities, with psychological characteristics, pleasures, choices, utilitarian evaluations sometimes dramatically transformed by social coexistence. The mass problem, on the other hand, such as that of distribution of general taxation on the basis of, for example, criteria of objective (in money terms) or subjective (in terms of sacrifices corresponding to tributes) equality requires the hypotheses to be updated so that they can be used for an interpretation of the solutions of the tax problems and a plausible explanation of these facts.

This is all the more necessary, logically, as it is precisely modern events that are further away from those that are by now less relevant, even if they exist at the same time, that were and continue to

be the subject of study for those, such as economists, who insist in the sceptical position in this field. Indeed, it is not only that the Crusoe figure belongs to fiction, but also that the individual subjected inexorably to the restriction of “*no bridge*”, that is to say with no homogeneous connection or link between his hedonistic decisions because of the presumed extreme autonomy and diversity of pleasures and utilitarian evaluations, appears to belong to the memory of a past that will probably no longer return. I refer to the establishment in the world, in a very impressive way, of the ideal of equality that pervades all forms of the ideal, more or less felt, of freedom in material but also spiritual life.

It is therefore not only that social evolution, in the context in which the subjects of the financial activity operate, makes logically necessary more fruitful hypotheses, in terms of their ability to interpret events, and turns into a historical memory, observing objectively, the events to which individualistic hypotheses of more dated economists refer. It is, however, necessary, in relation to new events as well, to have a hypothetical explanation that replaces the declaration of inability to explain or of the gnoseologic incompetence of this science whose objective, from the first pronouncement of a definition, I described as the explanation of the “modes” of distribution of taxation.

The hypothesis of a uniform mode to vary marginal utilities in function of the growth of incomes, for different individuals, on the basis of the individualistic vision, appears to some to be too far removed from the reality to be explained, to the extent of inducing the belief that “the discussion of the progressivity of taxation is not the task of economic science”. With such an hypothesis the “no bridge” situation is not an insurmountable problem. The rigid axiom of the inexistence of a *bridge* between individual hedonistic evaluations has the fault of truly viewing men, who on the other hand have much in common in terms of pleasures and choices, as little psychological islands. When hypotheses of this type are admitted (collective uniformity), it is on the basis of identifying explanations for mass problems, for which the recalled traditional positions of many academics seem to be inadequate. Of course, mainly as a historical note to the theory, we also consider the hypothesis of differing variations of marginal utilities, without their transformation in the homogeneous judgment of the governing class.

The comparisons of subjective utility, which are absurd for these atomistic views, are not so when it is presumed that, as for the maximum utility *for* the community, they are carried out by the governing class, with a homogeneous view. It is preferable here to give space to plausible hypotheses rather than to declare the hopelessness of science with regard to explaining the events of public finance.

II) Another confusion noted in the current literature, with subsequent rationally undeserved criticism, is represented by the belief that science should suggest criteria of distribution of taxes and not only try to *explain*, with the help of congruous hypotheses, the events brought about by the legislator to highlight their rational content, from precisely hypothetical points of view, in the context of the fiscal field.

When we come across statements such as this one by Einaudi, according to whom “economic science, it must be recognised, has no merit in terms of suggesting foundations for progressive taxes” (*Riforma Sociale [Social Reform]*, No. 4, 1933), clearly we are dealing with a confusion between precepts or financial “art” and gnoseological or explicative attempts, in terms of logic, of the “foundations” offered by the political classes. Even though it is through a procedure that philosophers define *abstractio formalis*, the study of financial economy isolates the economic aspect, here represented by the interference of the subjective variable (utility of income), to explain the hypothetical probable or plausible or credible involvement of this factor in the fiscal field. Thus arise the principles or laws of the theory that takes as its object aspects of events and phenomena.

Similarly, Barone (*Principii di economia finanziaria [Principles of financial economy]*) also comes to a conclusion not relevant to the scientific field, after concluding a critical review of the theoretical criteria for the distribution of the fiscal burden. When he writes: “All these minute analyses of the utility of the various parts of income, in addition to being lacking in any serious basis, are also unsuitable, in practice, to be translated into legislative formulae”, he reflects as though science also had the function of art, in other words, in the sense of giving suggestions on modes to resolve the real problem: that is to say, rather than that of using hypotheses suitable to explain the

event, an event made up of modes to define fiscal justice or fiscal equality and of real technical, mathematical and historical modes already adopted by laws for the distribution of general and progressive taxes rather than progressive and regressive ones.

D'Addario (“*Economia Internazionale [International Economy]*”, No. 2, 1952), who appears to have found the real methodology of hypothetical science when he correctly states, thinking about the modes of distribution of taxes, that the formulation of ideals of justice or the (just or unjust) judgment value falls outside the object of the science of finance, yet he also falls into methodological confusion. This is because, if those who have “researched”, “proposed” and “applauded” the principles of the distribution of taxes have made *art*, then so do those who have “examined” and “explained” any criterion, no matter how qualified, make (or have made) *art* by using, in a critical and constructive setting, the hypothetical procedure, whose choice is subjective and linked to the brilliance of the investigator and only for this reason, arbitrary.

In other words, it is true that the science does not have to be about, at least in terms of objective, the creation of laws of distribution of the taxes and that it does not have to claim to guide events directly (although taking into account, in practice, the scientific criticism of legislation is another matter).

It is also true, however, that scientific theory must be armed with hypotheses suitable to explain events, when they continue to provide rich, univocal and normal case studies. When faced with such cases, it would be a very poor consolation to conclude sceptically that, even by abstraction, in other words, when considering a single aspect of interest to financial economy (quantity of wealth and its utilitarian importance), it is a *hortus conclusus*: in other words, that the rational explanation of the arising and establishment of proportional and progressive taxes is a field forbidden to theory. And this only because, simultaneously, as a complex event (and how it will be explained later), these taxes respond *also* to other reasons that may be defined as political, statistical, relating to economic policy or objectively economic, etc., in the real event.

In conclusion, I do not agree with the opinion of those who (for example De Viti De Marco) even relegate to the field of policy only the possible explanation of the proportional and progressive tax, and do not believe that, by using adequate hypotheses, it is possible to explain the criteria that govern the distribution of the same tributes.

III) It should not be necessary to warn that “to explain” does not mean to justify the feelings and interests that inspire the criteria really adopted by legislators. Indeed, for the single aspect here considered, in the spirit of interpretation of mass phenomena, no value judgment with regard to the goodness, equity and justice of these criteria is admitted. On the contrary, *given* definitions of equality, justice, etc., it will be ascertained if the solution, rationally interpreted by academics, is, in the various hypotheses, coherent with the presumed (as given facts) definitions of justice, equality, etc.

In this sense, I proceed further in the planning of this chapter, which, by adhering to the traditional view of many academics who forget to admit to individualistic preferences, would otherwise not figure other than as a chapter in the history of theories. Conversely, I believe that by updating hypotheses that interpret reality – in the comprehensive sense of the socially developing trend of the behaviour of subjects in the context of typical choices, average pleasures and actions repeated with a frequency that indicates uniformity – it is possible to contribute to an explanation that is conditioned by the same hypotheses, rather than a fruitless and sceptical criticism of the prevailing reality. And indeed it seems to me that, as interpreters, we exceed in our adherence to old hypotheses in a traditionalistic sense when faced with the evolution of events in the sense of mass psychology asserting itself. In fact this is in contrast with the rigid “*no bridge*” position between utilitarian evaluations and current pleasures of men, still presumed to be psychologically completely independent and with the totally self-contained mentality of medieval stylites.

Above all, however, it neglects to see the problem from the point of view of the governing class that makes subjectively homogeneous these hedonistic evaluations, which already historically tend towards homogeneity in themselves. The (logic and historic) need “that the State replaces the evaluation of individuals with its own” is not, however, denied. Yet Einaudi for example (*Miti e Paradossi [Myths and Paradoxes]*), views as “school exercises” the theoretical reasoning at the basis

of the “invented” curve by the legislator or of the “zero economic substance” (pp. 164/165) because of the confusion between hypothetical concept and empiric verification that I will address later. Or there is the fear of obtaining infinite solutions that correspond to the “infinite number of imaginable curves”, as if this did not validate the position of the hypothetical approach in explaining the numerous progression scales already known and groundless and those of the infinite number that the future will present.

Having expressed this methodological and gnoseologic warning, I go on to illustrate the intuitions and demonstrations of the logic of proportional and progressive imposition from the limited point of view of public finance economy.

II.

INTUITIONS AND SCIENTIFIC DEMONSTRATIONS IN THE CONTEXT OF PRINCIPLES AND CRITERIA OR “MODES” OF DISTRIBUTION OF THE COST OF INDIVISIBLE PUBLIC SERVICES

A significant application of the thought expressed in Chapter II (*Le entrate pubbliche [Public revenue]*), that classification is not pure conceptual logic but presumes or implies the solution of theoretical problems, is found when proportional and progressive taxes, of which we have already given a summary definition, are compared.

Indeed for some time, studies, especially statistical and mathematical ones, based on the existence or on the hypothetical admission of taxes that are respectively proportional and above all progressive, have flourished without entering the field of the rational *genetic* explanation (we will see within which limits this is logically legitimate) to study their extrinsic characteristics.

However, strictly speaking, there is no logical independence even between: *a*) configurations and technical and mathematical characteristics of the type of tax (proportional and progressive) examined for the mode of variation of a sample of them and the rates, represented by straight and broken lines, continuous and discontinuous curves (concave, convex, etc., with respect to the x-axis); and *b*) reasons for their different behaviour, from the point of view of economic presumptions that are not only objective but also subjective (psychological *reactions* of the hypothetical taxpayers to the application of different types of taxes).

In even more general terms it is not possible to answer the following questions:

I – *Why did proportional taxes come about and why do they still persist in fiscal systems?*

This is a centuries-old question but nevertheless still current.

II – *Why has there been a switch, in the context of general and personal taxes whereby the rich and the poor are compared with regard to income and assets respectively available to them, from proportional taxation to a variously posed progressive one?* (The same can be said generally for the juxtaposition of proportional *systems* to progressive ones.)

Asking these questions means rationally (and historically) connecting taxes differentiated by their proportional and progressive nature to criteria and modes of distribution of tributes to sustain the expenditure for indivisible services.

The main, non-economic reason that has dominated the historical solution, not only with regard to individual taxes but for entire systems, is essentially that of fiscal *justice*, as generally indicated. We have seen in the *Introduction* (paragraph IV) how justice is of interest to financial economy experts as a *given* concept that can be translated into that of *universality* or of *equality*. Having admitted this shifting, we consider the problem of studying which rational and quantitative explanations are compatible with the concepts correlated to that of justice. That is to say, it is an attempt to explain in a logical-quantitative manner what has historically taken place or is imaginable in the context of distribution of general and personal tributes, under the influence of the ideal of justice that shapes law, ethics and history.

Before demonstrating whether the attempt to give a scientific explanation of the economic reason for the rising and diffusion of progressive taxation as a “more just” solution to the problem of the distribution of taxes or of the genesis of fiscal systems than that offered by proportional taxation is

the competency of the theoretical academic of public finance, it is necessary to mention the intuitions that have shaped the *law*, the ethics and the *precepts* phase of the development of the theory of public finance.

It should not seem irrelevant to this course to start with intuitions because they have created events or the type of *events* that this science should analyse and *explain*, whether they are already offered by history or simply hypothetical ones. And my definition of this science implies first of all the study of the *modes* of obtaining revenues.

So I will consider: *a)* juridical intuitions; *b)* ethical intuitions; *c)* economic (cameralistic or precepts finance) intuitions, in part to give a *foundation to the hedonistic hypothesis* of a uniformity of utilitarian evaluations, as seen from the State's point of view, which believes it to be more adequate than the individualistic or atomistic hypotheses in relation to the explanation of collectivistic events or mass phenomena such as fiscal ones. *a)* Juridical intuitions can also be found as a consequence of political revolutions that aim to achieve equality in the fiscal field too, in constitutional charters.

For brevity of reference, the reader should think of the Italian Statute of 1848 that proclaimed declarations analogous to those of the French constitutional rights. "They (the citizens) contribute indiscriminately, in the proportion of what they have, to the responsibilities of the State" is the wording of article 25 of the Albert Charter, which contains two concepts of equality: *a)* in the sense of *generality* of the duty (that was extended to *all* taxpayers), with the subsequent abolition of "privileges" that, at the time of absolute rulers, could be created for social classes and for individuals through the traditional means of the "King's Bill"; *b)* in the sense of *uniformity* of the imposition or of the economic equality of citizens with regard to the fiscal duty (quantitative problem).

In contrast to what literary interpreters had thought of the idea of justice canonised in the Statute, enlightened academics identified the concept of generality and uniformity of taxation as modes of being of equality, in the wording reported above.

(I illustrated this logical position in the text I recall here: E. D'ALBERGO, *Proporzionalità e progressività dei tributi nelle carte costituzionali italiane [Proportionality and progressivity of tributes in Italian constitutional charters]*, in the Annals of the Faculty of economy and commerce of the University of Palermo, 1949-I).

We need to recall some of the interpretations. De Viti De Marco, who was an experienced and wise politician as well as a brilliant scientist, among other things (in the 1928 edition of *Principii [Principles]*, pp. 155-159) stated that the statutory norm, as all declarations of abstract and absolute rights, does not have a concrete and positive content, so as to set proportional and progressive taxes as two modes of application of the equality principle. Similarly Graziani, eminent illustrator of theories and real orders, in reference to art. 25 of the Statute (in *Istituzioni di scienza delle finanze [Institutions of the science of finance]*, Utet, 1929, p. 279), stated that "it indicates nothing concrete with regard to the mode of distribution of the tax, and only expresses a concept of fiscal equality, also contained in previous constitutional charters, to uphold the principle of the disappearance of class immunities and privileges" and that the Statute appears to be conciliable with the progression of the arising tax and is accentuated in reforms that are "permeated with the spirit of fiscal progressivity".

This and other quotes by economists and jurists, in respect of which I refer the reader to my written notes, illustrate well how comprehensive the intuition of equality was in the fiscal field and therefore compatible with its realisations.

The Italian shapers of the new norm did not have such a wide vision and the wording in force in 1948 declares: "All have a duty to contribute to public expenditure in proportion to their contributory capacity. The fiscal system is shaped by criteria of progressivity" (art. 53). This obvious juxtaposition was meant to indicate that the abrogated old constitutional charter contained the technical criterion of proportionality. This is a mistake, according to the interpretation of the jurists and economists I named in my written notes.

Furthermore the contradiction of those who confused the general principle of justice implemented through equality with the technical regulations or specific modes of distribution of taxes is indicated by the realisation that the presumed rule in the Statute (contribution in proportion to one's worth) did not prevent our legislation evolving in some way in the direction of progressivity, without it being unconstitutional. Now, on the basis of which principle was this unconstitutionality unfounded,

if not on the basis of justice and the correlated one of equality in which it can be translated, and which admits the corollaries of proportionality and of progressivity?

With the unilateral reference to this technical criterion (progressivity), the creators of the new constitution believed they could open new ways for the modern actuation of fiscal progressivity, “with a criterion that is more democratic, more in keeping with the conscience of social solidarity and that conforms to the evolution of the most advanced legislations” (Scoca). As has been seen, there had been evolution even under the regime of the Albert Statute, as is borne witness by the progressive succession tax (1902), the extraordinary patrimonial taxes (1919–22), the supplementary tax on income (1923), etc., just to mention State ones (the family tax was also already progressive before the abrogation of Charles Albert’s Statute).

The fact that the system was shaped by progressivity criteria does not demonstrate that it was in fact, definitely or as a consequence, progressive, as tributes of this type can neutralise or compensate for regressivity (effects of taxes on individual consumption that have a non-proportional impact and sometimes are generally inversely proportional to income) or can be added to a preeminent (factual) proportional system. What matters – and that has not been proven to correspond to a new fiscal ideal canonised in the Constitution – to use Barone’s terms, to which I will make reference later, given the *components* of the system (partially regressive, proportional and progressive taxes), is the *resulting* historical statistics that are derived from it. And this *may* diverge from the constitutional view.

Over and above the criticism of the new text that intended to update or perfect the old Statute, it is of interest to confirm that one or other constitutional charter, as well as many other foreign ones, have revealed a more or less perfect expression of the intuition of fiscal *equality*. This concept, translating into the practically reconciled realisations of proportionality and progressivity, has attracted the attention of experts who, wanting or having to explain this version of an ideal justice, have used types of demonstrations to which I will shortly make reference to.

b) The intuition of fiscal justice as equality of treatment or burdens and sacrifices experienced by the taxpayers, however, is more or less clearly expressed and interpreted in the consciousness of populations. This justifies the assumption of the hypothesis that we have hedonistically considered more appropriate in explaining these mass or collectivistic phenomena.

I have started with an example of canonisation, in a legislative context, of the view that dominates popular consciousness because the legislative *datum* is that which is more immediately outlined for the economy theorist who must give an explanation, at least in general terms, of the logical significance of the modes of distribution of taxes, as canonised in fiscal law.

However, the prevailing opinion in the context of fiscal justice is instilled in the law, especially in the case of documents, such as constitutional charters, that are the result of revolutions of ideas and of social systems driven by feelings and “consciousness states”. Referring to “consciousness states” or to prevailing opinions may appear irrelevant work in this treatise. However, those who have understood, considering the *Introduction*, the value of hypotheses in sciences and in our science in particular, may appreciate the links with events, in the attempt to find an explanation which is also an economic one for the progressive tax that represents overcoming, in the context of personal taxation, the ideal of justice that, in a first approximation, was represented by the proportional tax.

The intuition of personal or subjective equality in imposition of taxes and contributions, generally, in public affairs has been, normally and for centuries, presented in the following terms if all net (and I add, global) incomes were to be taxed at 10 per cent. For example, an individual with an income of 1,000,000 liras should pay a tax of 100,000 liras, and an individual with an income of 100,000 liras should pay a tax of 10,000 liras. It is true that the objective economic position, in monetary terms, remains unchanged. The first individual, however, experiences a lesser psychological burden or sacrifice by being deprived of a tenth of his income, compared to that experienced by the second, less wealthy, individual. This latter assigns a greater economic importance or a greater utility to the share of the sum collected from a lesser income compared to the needs to be met, to which are assigned the portions of income not collected by the public body as a tax.

This statement may, indeed, be presented as an intuition but it is not yet a thought that can be considered a scientific demonstration. And a generalisation of very widespread “states of

consciousness”, which can be taken as hypotheses in explaining the probable and credible mode of argumentation of the governing class who, referring to typical subjects and groups, may judge the sacrifices imposed on components of the community according to this popular intuition.

These “states of consciousness” are also recalled in the context of those argumentations on individualistic hypotheses by theorists who attempt to explain the logic governing the development of tributes, from the proportional criterion to the progressive one, including when a negative conclusion is reached, even to the point of stating that the explanation in subjective terms (sacrifice of utility or of enjoyment) of the progressive tax is not relevant to economic science.

Even though insisting on the difficulty of measuring in an objective way the diversity of sacrifice, my predecessor in the chair in Bologna (Flora) in his *Manuale [Manual]* admitted that it was not possible to “destroy the primordial fact” that the value of 10 for those who own 100 is “much higher” than the value of 100 for those who own 1,000. Similarly, Pescatore (*La logica delle imposte [The logic of taxes]* 1867) had for a long time suggested that the opinion of practical men is not persuaded to adopt progressive taxation by concerns about the effects of the system, “but rather because they feel there is something true, and the value of equity in the progressive doctrines”. Ferrara differentiates (in *Lezioni [Lessons]*) the case of the proportional tax where income is viewed as a “dead body”, independent of whoever it belongs to, regardless of the moral effect that it has on the “psychology and morale of man”.

In the heat of the debate, Einaudi admits that the foundation of the progressive tax is based on concepts of equality, of justice, in the needs of the collective “conscience” and of common sense. He also believes that the politician should abide by the plain ideas in the heart of men (“*La Riforma Sociale*” [*Social Reform*], 1933). He does however negate that this is of interest to economic science, as if this had not always studied the hypothetical behaviour of men in the deployment of means to meet public needs.

Myrdal (op. cit.) talks about the need of equality to define the rather subjective, or possibly demagogic quote (which I will shortly make reference to) by A. Smith. He judges it, rather superficially, to be devoid of “deep content”.

L. Rossi discusses “general conscience”, of “widely understood criteria of justice”, of “widespread opinion that, whether large or small, the same percentage takes more away from the poor man than from the rich one”, of “general awareness that a proportional tax is heavier on the poor man than the rich one”, etc. (*Sull'imposta progressiva [About progressive tax]*, 1932). He does so by trying to demonstrate, with appropriate hypotheses, progressive taxation through the analysis of economic and hedonistic quantities whose variations reflect popular feelings or universal states of consciousness.

Robbins mentions an ethical postulate with regard to the “social utility” considered by public finance: he denies that there are means to ascertain the extent of satisfaction (and therefore of the sacrifice) of *A* in comparison to that of *B*. He does however admit that “in daily life we continue to assume that this comparison can be made” (*Sulla natura e importanza della scienza economica [About the nature and importance of economic science]*, Utet). This is meant from the point of view of third parties and the State in particular.

In discussing equal, regressive and mixed taxes, Fasiani, faced with a numerical example of absolutely equal taxation (capitation, or so much per person) different from the one mentioned above, states that “no man with good sense would question that asking a payment of 1,000 from someone who has an income of 6,000 per year, in the same way as from someone who has an income of 50,000 or 100,000, is not the best way to achieve equality of sacrifice. The sacrifice imposed in this way on the poor man is, in the universal opinion, greater than the sacrifice imposed on the rich man”. “No elected class will escape this common opinion”. And regarding proportional taxation and progressive taxes, he again states that “men are universally inclined to believe that a tax of the same entity causes a greater sacrifice to the poor man than the rich man, and the poorer the man the greater the sacrifice”. He continues: “even though we know nothing about the absolute extent of the utility of income of these subjects, and that we know little about the extent of the difference of their marginal utility, nevertheless we know or *we believe* that there is a difference”. And he acknowledges simple and

rough ways of thinking on the part of the elected class, in the same way as common sense suggests to normal men who live everyday political lives.

Furthermore, when Fasiani mentions the way through which it is possible to give a scientific explanation of human behaviour, that is to say that these ways of thinking of the elected class reflect on the one hand the average or representative figure of frivolous categories of beneficiaries of income and on the other the behaviour of diverse average types, he fears being the subject of criticism by those who deny meaning to the concept of representative taxpayers. He believes this even though he realises how difficult it is to specify the concept of normality on which, furthermore, nearly all economic science is based with regard to the operating subjects whose behaviour it seeks to analyse (*Principii [Principles]*).

With regard to the theoretical scruple in respect of the possibility of proceeding to comparisons of relative utility of subjects with different pleasures and different means to gratify them, L. Fraser, the current censor of the methodology and propriety of the scientific approach, specifies that the difficulty (in comparing utilities and therefore sacrifices) regards only *accurate* and *quantitative* comparisons. According to Fraser: "Economists sometimes talk as if the utility of different people is so completely immeasurable that to say that an asset has the same or a different degree of utility for two different people would make absolutely no sense. This opinion is entirely candid from a technical point of view: that is to say, it implies a doctrine that no one would seriously try to adopt in ordinary life, and denies the possibility of something that, in fact, happens all the time. We all do comparisons of this type. Every father or mother, every subscriber to a charity, every Finance minister does it and must do it; this is because it is the task of every one of them to decide how to distribute among other people (members of the same family, beneficiaries of a charity, citizens) the limited quantity of means available to them so as to maximise the possible utility. And to do this he *must* ask himself if a shilling (or a million pounds) will be better spent for one person (or a category of people) or for another; this means that he must compare the utility of a given quantity of assets for all of the possible diverse beneficiaries" (see *Pensiero e linguaggio [Thought and language]*, etc., Utet).

Einaudi declares, with argumentative vehemence (*Miti e paradossi della giustizia tributaria [Myths and paradoxes of fiscal justice]*) that these are feelings: but they do give substance to what is the juridical conscience of a nation (as Cohen Stuart calls it) and flow into laws that are the facts on which economy tries to shed some rational light, with the help of adequate hypotheses.

In the international literature there is continued hypothetical discussion, as we have said above, with regard to the *common idea* that the variable marginal utility, whose trend is assumed, can explain an aspect of progressive taxation, to explain the presumable fiscal action on the part of the State.

I do not want to close this compilation, from which the existence of a consistent and general thought – even though through pro and against positions and against the admissibility of theoretical bases of the progressive and proportional taxation, in the light of the equality of taxation – about the position of the rich and the poor with regard to the utility of the wealth or of the income and the sacrifice that is implied in renouncing them, without remembering – as I have done for more than a decade – the greatest expression of human conscience, an interpretation which has not disappointed before. It implicitly introduces the hedonistic variable that, according to the hypotheses used, explains fiscal equality on the basis of the proportional, progressive and regressive tribute, respectively.

Indeed, in the context of public contributions, Jesus Christ, in the evangelic text that no one before me, as far as I know, has interpreted from this scientific point of view, comparing the great offering of the rich with that offered by the poor widow, believed it was the common woman, who had offered (in money) a smaller sum that was however everything to her, who had in fact contributed the most (clearly in terms of sacrifice of utility). Continuing with the implicit reasoning, the utility of what is needed for "sustenance" or for "life" is greater than that of "superfluous" wealth. So that to contribute in a similar manner, for example with equality of sacrifice of utility, it was necessary, in this case, that "all the others" ("many rich people") should have offered much more than the "large amounts" observed by Jesus Christ. He *probably* thought: 1) about contributions that were more than proportional to the wealth of the members of the populace "who contributed money" to the temple

treasury, in this case they had contributed in a proportional manner; 2) about *accentuation* of the already presumed and observed progressive contribution. I have appealed to divine wisdom, as consecrated in the Gospels¹³², wisdom that is reflected in the conscience of the masses that, in simple terms, include the variable of sacrifice in the collection of wealth from more or less rich taxpayers. Can science really, when faced with the concept of fiscal and social justice so highly stated, declare to be so incapable of offering a logical explanation?

Therefore the fact to be explained, with the help of hypotheses, as happens in all sciences when *ad hoc* experimentation is precluded, exists because the collective or human conscience permeates constitutional declarations and individual fiscal laws in which proportionality is affirmed alongside the progressivity correlated to the personality of fiscal laws¹³³.

The ancient intuition expressed by the highest interpretation of human and collective conscience cannot be left in its evident eloquence without the small human mind being able to retrace, with the current instruments of analysis, the hypotheses and the observations on which it must have been rationally based. Similarly the admissions, in the compilation of other quotations, indicate that the fact exists and deserves and requires scientific explanation.

c) Still at the stage of intuition, it appears to be the expression of the principles or canons of taxation, as they were viewed in the first definition of economic science.

The thought runs to the canons of taxation and, first of all, to that of A. Smith who suggested, in the form of precepts: the subjects of every State should contribute to the support of the State, as much as possible, in proportion to their ability, that is to say in proportion to the income they respectively enjoy under the protection of the State.

In this sense Smith was preceded by Petty, Pietro Verri and others. In the previous edition I have recalled the position of a “cameralist”, Carl, whose thoughts I report to say that this author’s second principle suggested that taxes should be proportional. Now I will recall how even the title (*Traité de la richesse des princes e de leurs états et des moyens simples et naturels pour y parvenir [Treatise of the wealth of princes and their States and simple and natural means to manage them]*, 1722) indicated how intuition is more of assistance to history (art of government) than to logic. In other words, at the stage of precepts, which culminates in the proposition by A. Smith, it cannot be said that a rational explanation has yet been attempted for progressive taxes from the point of view of the theorist of economy, within the limits of what he can say about the subject.

It has been mainly the interpreters of Smith’s concepts, in terms of the diffusion they have found in the world, to have asked what might be the implication of the concept of “ability” or capacity to contribute or possibility represented by income or, as we have seen in the Italian statutory context, by the “wealth” of taxpayers.

For the most part, they have also been of the opinion that Smith did not intend to adhere so closely to the criterion or technical mode of distribution of taxes represented by proportionality in a technical sense. Also with Smith, the idea of proportionality was a mode of expressing the equality of taxation. Do reflect on the wording with which we start, even in terms of intuition, the explicative

¹³² Parable contained in: a) Chapter XXI of the Gospels according to Luke; b) chapter XII of the Gospels according to Mark.

In the Gospels according to St Mark it can be read (The widow’s offering):

“Then, sitting in front of the Gazofilacio (the Treasury building), he observed the crowd putting their offering into the temple treasury, and many rich people threw in large amounts. A poor widow came and put in two very small coins making up a quarter. Calling his disciples to him, Jesus said to them: ‘Truly I tell you, this poor widow has put more into the treasury than all the others. They all gave out of their wealth; but she, out of her poverty, put in everything, all she had to live on.’”

And St Luke says, in the same parable: “Looking up, he saw the rich people putting their gifts into the temple’s treasury. He also saw a poor widow put in two very small coins, and said: ‘Truly I tell you, this poor widow has offered more than all the others. All these people gave their gifts out of their superfluous wealth; but she out of her poverty put in all she had to live on.’”

¹³³ These references to the Gospels, that had not been used in other treatises, were included in the 1942 edition of these lessons for good reason and to demonstrate that, if she (the widow) who had given less in monetary terms had in fact given more, this differentiation of duty must be based on hedonistic, extra-monetary quantities, that is to say on sacrifices of utility.

interference of the “utility” or “sacrifice” variables, not in terms of money but of hedonistic entities, with the following ideas from *Wealth of nations*” (Book V, Chapter 2): the rationality of the rich contributing to public expenditure in a greater proportion than the poor, as for the rich the capacity to contribute increases more than proportionally to the growth of wealth. This is the first intuitive vision of what, in recent times in economic science, has become theoretical analysis with the intervention of the element of marginal utility of income or of wealth generally.

In any case the intuition of academics who have concluded their ideas with synthetic statements on the mode of obtaining contributions to public expenditure, too, as well as the constitutional declarations and the common opinions that the words from the Gospels have raised to universal truths, require the endeavour of theory for the demonstration of these same juridical, moral and economic intuitions, on the basis of the instruments of logic and of observation (if not exactly the statistical experiment).

Having recalled all that has been mentioned in the preceding paragraphs *a)*, *b)*, *c)*, our science cannot declare to be “a priori” impotent when faced with the need for a demonstration. All the more so because, as I have observed, above all there is a persistence of the confusion between concerns of pure knowledge and requirements of practical application, between rationality of conception and the possibility to verify by measuring and empirical comparisons on the part of individuals and not of the governing class.

These latter distinctions have, for example, affected Borgatta’s thought to such an extent that he took a further position against the criticism of the assumptions of the progressive tax.

After these criticisms, especially those by Einaudi – to which we will return – in reviewing the lessons of d’Albergo’s *Scienza delle finanze* [*The science of finance*], in the “Giornale degli Economisti” [Economist Journal] of 1947, he stated: “Einaudi should also consider this observation. The application of the progressive principle, from the First World War onwards, has become a general and “normal” fact, characteristic of the fiscal legislations of nearly all countries. If we refute the principles deduced from the decrease of marginal utility of wealth, what scientific explanation can we give for this financial phenomenon that can be said to be universal? It remains a fact, but merely a political one: is this the conclusion that Einaudi wants to reach?”

The answer, I repeat, has already been given by this author *ahead of his time*, as he believes that it is not the pertinence of the economic science to deal with the progressive tax, which would be completely out of its field. It is something else, however, to say that many factors influence the real solution, i.e. the practical modes of being of progressivity; it is something else to deny, for reasons that are mainly empirical and linked to the rigidly individualist hypothesis criticised above, as socially inadequate for our time (non-measurability and non-comparability of hedonistic quantities), the possibility of abstract hypothetical conception of the demonstration of this *mode* of being of the fact or of the phenomenon of public finance. In this very century, that has seen entire populations take a uniform approach to vegetative life and even in the field of the activity of the spirit, following, without sensible reactions, ideological conceptions and concrete modes of living, sometimes programmed for the community by minority governing classes or shapers of consciences and pleasures.

The preceding quotations and references at letters a), b) and c) aim towards the understanding of how the hypotheses to which I have made reference, derived by multiple theoretical analyses, are not distant from reality or against reality, if the law, ethics and intuition of the first economists assume them to be suitable for the interpretation of the events that give substance to progressivity of taxation.

III.

FURTHER METHODOLOGICAL WARNINGS FOR A RATIONAL VIEW OF THE PROBLEM

Before we delve deeper into the hypothetical demonstration of the logic of the modes of distribution of the cost of indivisible public services by means of progressive taxes (in addition to proportional ones), it is necessary to suggest a few words of caution.

I) In contrast with what can be read in some treatises, even Italian ones, we conform to the *succession* of problems, as in the definition that has already been given in financial economy as content of the science of finance. That is to say, that the “modes” according to which the State and other public bodies can procure the means (to sustain the expenditure needed to meet public needs) are analysed before the study of the variations of particular or partial economic equilibriums, variations that are attributed to the collection of a quantity of wealth and its distribution onto the market.

This vision responds to rational premises: that is to say, to a view of universal character with which we treat the matter here.

I refer to the genesis of financial science and its relative problems, first of all in function of the fiscal constraints that modify the conditions of the economic equilibrium, constraints that are considered as *given data* relating to problems from several years in these lessons.

In other words, the problem of the *mode* of distribution of tributes and therefore to create constraints whose interferences in economic relationships need to be analysed will be presumed to have been solved. This analysis will follow after the consideration of the coherence and of the logical admissibility of the rationality of the modes of collection of tributes, which is as central a problem as that of the study of the effects of tributes. This methodological warning derives from a significant logical question. Indeed the influence of the effects or otherwise of tributes on society, as modes to distribute the cost of indivisible public services, cannot be denied. I will say more about this and in more detail in the introduction to the study of the economic effects of taxation. For now I will warn the reader that, in the opinion of many, this influence has sometimes a practical character for the solution of the empirical problem or in the context of a concrete application of principles that live *their own life* in the field of *logic*, independently from the effects they will cause.

Indeed, when Einaudi, in the course of discussions of the logical premises of the progressive tax, states that the study of the effects of taxes “serves” the same legislator; when he presumes that the politician, obeying the command of justice, has instituted the progressive tax and economic science fulfils the task of the slave sitting behind the victorious leader with the task of reminding him how easy it is to go from glory to ruin, the illustrious author confuses theory and practice.

I will give an example. We will be seeing shortly the properties of a *mode* of distribution of taxes, shaped by the principle of the minimum collective sacrifice. The logical consequences of the principle could hypothetically lead to a levelling of fortunes or riches. In that case, once the argument is settled, practical concerns arise. The same Edgeworth suggests characteristics and expedients to take this into account, for “consideration of the development of wealth and other advantages”. These are arguments on different bases from the strictly rational one of deduction in the mode of distribution of the tax in the context of pure theory, on the basis of given hypotheses (and definitions of justice).

A distinguished North-American author must be kept in mind, who in these lessons and in many other treatises will have the study of the *effects* of taxes follow on from that of the *modes* of collection of the same. Taylor (*The Economics of Public Finance*) admits that the “choice” between proportional and progressive tax gives place to “uncertainties” (p. 293). This helps us understand that we are in a theoretical context but with a solution to practical problems in view, as the academic does not have concerns with regard to choice but rather the task to analyse *per se* the individual modes of distribution of taxes. And when he admits that the uncertainties of the progressive tax can, to a certain extent, be mitigated by “amendments after the observation of the effects of the scale of rates on the various classes of beneficiaries of income”, it can be understood how the link between the consideration of effects and types of distribution of progressive taxation is concerned with the *real*, as it is not possible in the laws of thought to have an amendment in the thought processes that give substance to pure theory. Lines of reasoning are logic or otherwise and not worthy of amendments, as these are concerned with the empirical field, in view of practical objectives or of historical applications of systems and theoretical systems.

II) Another warning is that which concerns the logic independence of the problem of the collection of tributes (on the basis of criteria in which the variable utility of wealth is used) from the problem of the utility relating to public services.

If we leave aside, in the context of an analysis of criteria shaped by the hedonistic variable, the utility of public services, what happens is: *a)* both because, by definition, it is a matter of modes of distribution of services at indivisible cost and utility; *b)* and because, no matter what can be found to be *objectively* divisible in the issue of tributes, by homogeneously comparing monetary collections and monetary advantages or translatable in equivalent quantitative objectives, it will be said with regard to the criterion of (relative) contributory capacity. For coherence of vision, it is necessary to renounce to the measurement of (subjective) utility of public services for the benefit of rich people or poor people or of subjects having different sums of wealth to satisfy private and public needs.

With regard to point *a)* I want to recall a particular contradiction into which, from various points of view, the great genius of the name of Ugo Mazzola runs (*L'imposta progressiva [Progressive tax]*, Pavia, 1895). He considers the hypothesis of the trend in the utility curves as presumed by Cohen Stuart or Bernoulli to be arbitrary, and "arbitrary the average of arbitrary hypotheses". Furthermore he confuses conception and verification, in other words theory and empiricism, by stating that "nothing proves" that the utility curve is the one hypothesised by the above mentioned authors.

Mazzola, however, does not hesitate to put forward a hypothesis no less arbitrary than the one he criticises in order to explain progressive tax: "It is quite probable that it can be demonstrated that the sum of differential utilities realised and subsequently accumulated by the beneficiaries of increasing incomes allows a comparatively higher evaluation of the utility of public services". The author connects this hypothesis with the simultaneous principle of growing productivity or growing rewards, in the sense that "subsequent investment of wealth in the same services gives, up to a certain limit point, a result that is more than proportional to the units of wealth invested". Everyone can see the extent of discretionary interpretation, with regard to the facts that have concerned the critics of the rational and utilitarian explanation of progressive taxation, in this Mazzola's "principle".

The increasing rate of tax could be explained by admitting that "public services, considered as coefficient of production or of enjoyment, acquire an absolutely higher utilitarian character depending on whether the productive investment and the enjoyment allowed by growing incomes occur" (p. 57).

However, Mazzola, with this construction: *a)* transfers into the field of the utility of public services the discretion and the theoretical difficulties he identifies when he criticises the writings of others, based on the variable of decreasing utility of income, on the fringe; *b)* does not avoid the criticism of non-comparability and non-measurability of objective utilitarian evaluations, with which he complies following the example of other authors; *c)* does not give an explanation of the mode of variation of the more than proportional taxation among the infinite rates of variation conceivable on the basis of the greatly arguable growing utility of public services with the growth of realised and accumulated wealth; *d)* he brings us to the "moment" of production of wealth, where we are discussing the explanation of personal and progressive taxes commensurate with the overall available and enjoyable wealth (*after* the "moment" of its relative production).

In conclusion, there is no step forward in the scientific field with the introduction of the utility of public services in the context of explaining the modes of distributing tributes. In any case, arbitrary principles or hypotheses are contrasted with another arbitrary hypothesis that cannot be rejected (decreasing marginal utility) on the basis of the characteristic that is common (arbitrariness) to the principle and the hypothesis offered by Mazzola.

III) As far as the claimed contradiction to which Mazzola also alludes (p. 42), between decreasing marginal utility of income and increasing cost of obtaining the same, the following observations apply. Indeed, in this critical demonstration or presentation of the modes of distribution of (proportional and progressive) taxes we leave aside the sacrifices or the cost of obtaining the wealth that we presume to be available in the hands of taxpayers. We therefore ignore the fact that wealth has been obtained with differing effort (in the context of its production), including the case of its free accession on the part of taxpayers (through donation or succession). In fact, as it has been indicated (by L. Rossi, op. cit.) with regard to the introduction of this circumstance (by De Viti De

Marco) in the line of thought that assumes as base the utility of wealth, the logical suitable context (hedonistic equilibrium in the production of wealth) is different from the one relating to the distribution or the consumption of wealth.

I do not deny the influence that one phase (production or achievement of wealth) exercises on the second (distribution or consumption or enjoyment). The popular opinion, that the wealth that is easily obtained is easier to spend than the one that we have worked harder to produce or obtain, would otherwise have no value. This means that wealth is appreciated less, for example, when it is inherited or obtained through a win in one of the types of lottery that human society has organised. This is however a non-univocal first approximation, which even admits the contrary hypothesis.

In fact, in my shifting of Stamp's *Principii [Principles]*, it is stated, for example: "Perhaps the most qualified person to judge whether a given scale of progression ensures an equal marginal sacrifice is the one who has passed, in a short time interval, from one situation to a very different one following a great change of fortune, even though he might be so moved by his sudden increase in wealth to consider lightly his new obligation, until he has got used to the social necessities and standard of life in the new circumstances of his income. As Pascal writes: habit is a second nature which destroys the first", (p. 427 of Vol. IX, *Nuova Collana di Economisti [New Economists Series]*).

This is so after recalling, with Chapman's words, that marginal utility of money can be greater for one person after his conditions have improved: "It is common to meet people who have achieved a little increase in income and whose enjoyment of life have naturally increased in a completely disproportionate way to the increase in income (pp. 421-422).

In any case, especially in a treatise such as mine, about the *qualitative differentiation* of taxable income, in which the subjective utility variable will dominate, the genesis of available wealth will find a suitable logical context.

IV) Finally, it is not considered that, logically, the study of the effects of the operation of "constraints", as modes of distribution of tributes, should precede the choice of modes or criteria of distribution of taxes, because this rational position is more appropriate for academics of financial policy, as we have seen in the *Introduction*. The methodology of this discipline, as it will be remembered, considers relationships between means and objectives which presume, through logical necessity, the general notion of *the effects of means* chosen as being suitable to reach specific objectives. The sceptical Kendrick (*The Ability-to-pay Theory of Taxation*, in *American Economic Review*, 1939), after having offhandedly defined as "defective" the hedonistic criteria of decreasing utility and sacrifice, without bothering to explain the reality of these reasons in the legislation, in the ethics and the same hypotheses of academics, suggests abandoning the "nebula of hedonism". Progressive taxation, in his view, must be founded on the *reality* of the economic system, and decisions must be founded on economic considerations. Taxes collected by collective action have economic effects, with consequences for society; and the choice of taxes with preference for some of them needs to be seen in the light of the economic and social effects of them: this, concisely, Kendrick observes as if he was discovering a novelty, after what we have seen and will see in these pages. From this aspect, however, after skipping the problem of the explanation of the sense in which the hedonistic variable can influence, how it *really* probably influences, the distribution of taxes, he takes his stance from the point of view of financial or fiscal policy: choice of means with respect to objectives; or he takes into account empirical motives, that are listed at the end of this chapter, to indicate the principal factors that contribute to determining the real progressivity of taxes.

This view of Kendrick is not the necessary and rational vision of the problems of economic theory of public finance that *may* consider, independently, the logical bases and the coherent characteristics of the *modes* of distribution of tributes *given* the *definitions* of justice, equality, etc.

In the chapter that will have as its subject the economic or factual distribution of tributes (effects of taxes), we will start from *given* formal distributions of them: in other words, from the hypothesis of *modes* of legislative distribution to the analysis of the consequences that will derive from them with regard to the relationships of exchange between individuals and the quantities overall considered: production, consumption, etc.

IV.

LOGICAL LEGITIMACY AND THEORETICAL INVENTIVENESS OF THE
 HYPOTHESIS OF A “TYPICAL” DECREASE IN THE MARGINAL UTILITY OF INCOME
 FROM THE POINT OF VIEW OF THE GOVERNING CLASS ON BEHALF OF MEMBERS OF
 THE COMMUNITY

Having made these premises on the methodology, it would be appear to be opportune to abandon this attempt in consideration of the refusal to include the explanation or the demonstration of what is dominant intuition in the competence of financial science and also in consideration of the authority of those who criticise the economic theory of a progressive tax. With regard to Italy, I will limit myself to mention two representative authors: De Viti De Marco, who finds the explanation of the tax almost exclusively in the political field, denying that it might be rationally identified in the economic field; and Einaudi. I have made reference to this author already and for this reason I will consider him first.

Generally these authors (who are not in the majority in thinking along these lines) justify their approach on the basis of statements such as the following ones:

1) From an extremely individualistic point of view, that is to say, by referring to all the individual components of the community (and not “satisfied with a curve of the utility of income” that the “legislator presumes to be appropriate to the so-called average man abstraction”), Einaudi states that in the current state of our knowledge no one has managed to bridge the gap between: i) the different and unknown individual evaluations of the curve of the utility of wealth; ii) the uniform State evaluation.

2) There is no such a thing as a psychoscopy (“moral manometer” as Loria defined it), that is to say, an introspective tool able to take a snapshot of each man’s quantitative psychological reactions when faced with the acquisition or deprivation of successive units of wealth. Such an instrument would be the “necessary precondition for the construction of a rational type of progressive tax”.

3) There is *no bridge* between the consciousness of one and that of another.

4) The presumption that the scale of decrease is the same for all is an “entirely unrealistic” hypothesis.

5) The scale of decrease is not uniform but rather variable, and variable according to rules that are unknown or known in an imperfect way so as to make their measurement impossible.

6) There is no logic in finance just for the sake of it. The practical financial expert is not inclined to indulge in the abstract exercises that are on the other hand useful for the purpose of training the young to reason.

7) When economists have devised a safe theory on the measurability of utility, then in turn financial experts will be able to consider the problem and the statistics offices will produce (utility) measuring indices. (For these and other statements I will refer the reader to the *Principii [Principles]* and to *Miti e paradossi della giustizia tributaria [Myths and paradoxes of fiscal justice]* and other already quoted sources.

De Viti De Marco denied the economic theory of the progressive tax with less polemic vigour but no less firmness:

a) The principle of added value does not allow comparisons of sensitivity, that is to say, of pain and pleasure, of sacrifice and enjoyment, between the different individuals, nor does it allow the hypothesis that the scale of sacrifice is the same for the tax payers (hypothesised in a numerical example). If anything, it is actually “more likely” that the scales would be different: at similar levels of income the pain or sacrifice (of the same tax) of two taxpayers “may be” and “as a rule” will be different.

b) The progressive principle would be demonstrated in the independent context of each individual economy, and its implementation would be impossible because of the theoretical impossibility of comparing the progressive scales of the various taxpayers, and the technical impossibility of establishing taxes for each individual.

These statements are enough to highlight the confusion in points of view that are yet methodological and logically heterogeneous. Furthermore, these authors (and other such as Barone, Fasiani, etc.) do not make space, as is the case in all sciences and in physics in particular, for the hypothesis in the context of research or analysis or abstract reasoning.

The many who, most likely, inwardly criticised thegnoseological value placed on the hypothesis in sciences, and in this one in particular, in what may appear to be a long-winded *Introduction* to this chapter in the course of these lessons, now can realise the importance necessarily added to the assumption of some premises in the logical reasoning for this fundamental problem.

A) Indeed Einaudi and De Viti De Marco (recognised as reputable experts, representative of a sceptical approach in the context of the economic theory of progressive tax) confuse the atomistic view with the mass vision that, as we have had reason to say before, is more appropriate in the explanation of a collective phenomenon and of State decisions referring to the entire community.

B) They confuse the hypothetical conception of trend variations in economic quantities and their characteristics, and practical or exact measurements of the same quantities, furthermore exactly and absolutely so measured.

C) They confuse the technical and practical possibility of applying legislative criteria (practical finance) and pure knowledge objectives (theoretical abstraction).

D) De Viti, Einaudi and others (Fasiani, for example) confuse the scientific determination of the sacrifice of the various subjects or of the structure of their curves of utility, which correctly mean the logico-hypothetical determination of mass hedonistic problems, with the historico-statistical understanding of utility curves. [It is something else to say that, as curves of utility are statistically unknown, there is no hope of giving real (and by that we mean practical) meaning to the utilitarian principle (in the case of proportional sacrifice, for example, which will be discussed later)].

Now, before considering the logical and symbolic instruments needed for the hypothetical demonstration of the intuitions and the facts they inhabit (fiscal laws that exist and that generally develop in terms of numbers and historical significance), it is necessary to trace the logical need for such a demonstration in the thought of the same authors here mentioned, as sceptical critics.

Indeed Einaudi recognises the abstraction of the average man that explains the activity of the State governing class but, as a theoretician, he does not accept it. He sees it as more legitimate in reality (from the point of view of the legislator) but hypothetically not rationally legitimate from the point of view of the academic. It would appear that we cannot avoid the objective of knowledge even when we carry out academic exercises. That “each individual academic’s conviction is formed on the basis of what he believes to be the sensitivity of the average man with regard to successive portions of wealth” is a hypothesis that cannot be said to be “entirely” unrealistic or in complete contradiction with reality, if intuitions *a*), *b*) and *c*), which I have illustrated in the previous paragraph, are derived from the interpreters of the reality that the academic is attempting to explain.

After stating that “in the matter of foundation, justification, basis, starting point for the distribution of taxes we stumble so completely in the dark that we need to grasp at any *grappling hook* we come across to carry on”, Einaudi resigns himself to the acceptance that we are dealing with “grappling hooks, expedients, predilections, etc., anything but economic or scientific propositions”, and does not contemplate the idea of the hypotheses that any science makes use of.

De Viti makes reference to the *probability* that the utility scales of the various taxpayers might be different, not to the *impossibility* of the contrary (in the previous quotation): science is based on the probability that the hypotheses might interpret the reality to be explained or might approximate it, without in any case having to declare itself impotent to explain facts. In our case, the theory is unable to demonstrate the general and universal intuitions, acknowledged even by those so-called sceptic authors, such as the ones we have quoted, and those who find themselves in this debatable methodological and logical order.

For the purpose of directing students and readers towards what seems to me the most correct and logically legitimate demonstration of the intuitions that dominate the distribution of (proportional and progressive) taxes, I will remind them not only that the issue of the setting of science problems has been abundantly covered in the *Introduction*, but I will also specifically recall the thought of some

economists who did not consider the theoretical study of modes of distribution of the burden of taxes as being outside their remit.

First of all, however, making reference to the first chapters of these lessons and the introductory paragraphs of this chapter, I must again recall that the genesis of the tribute that is *not a free* but *an imposed* price as a proportion of reimbursement of the cost of services with indivisible utility could similarly not be considered to be rational, if we took mental stances akin to those critically exposed here. The maximum utility *for* the community, rationally conceived by Pareto, could not be admitted either in itself nor for the use I have made of it in the univocal juxtaposition of tributes to non-tributary revenue forms. Also, in this case it was a matter of building *bridges* between the ophelimities or subjective utilities of the individuals, for the explanation of the quantum to be collected to satisfy public needs, that is to say, imagined or interpreted by the State in the Pantaleonian spirit of collective hedonistic maximums, imagined and evaluated *on behalf of* several individuals by a third party. Nobody claimed, as far as I know, to want to give historico-statistical value to the coefficients used in the Paretian equation to denote the maximum utility *for* the community. These are coefficients of variation of subjective utility referred to individual subjects or typical groups of members of the community, hypothetically considered to give a rational and economic explanation of the phenomenon. And the hypothesis did not appear to be “entirely” different in reality from those mentioned before or those of other masters of pure economic theory. And yet quantitative variations and comparisons of utility are used in the calculation carried out by the governing class to make them homogeneous.

The concept of the typical or average subject, presenting the most frequent characteristics, is the one that seems to end up also dominating pure economic theory constructions in any case. In the previous edition of these lessons I wanted to recall Pareto – who was at one time a master of methodology, logic and real approach to problems – to deny logical value to the objection about non-measurability of utility. I will come back to this later. For the moment I will refer to Pareto in order to remember that “a general theory must be judged on the basis of general and average facts” (*Corso [Course]*, Vol. I, p. 25). Pareto makes reference to the concept of the average type or the most frequent mode of reaction of the economic subjects to the varying units of available wealth or rather in the context of ophelimity, supporting the hypothesis that can allow the demonstration of the incontrovertible intuitions of type *a*), *b*) and *c*) expressed above.

I make some meaningful suggestions for the purpose of resolving the problem in these pages, in the theoretical context of tax distribution.

“*Strictly speaking*, no comparison between the ophelimities of two different subjects is possible. The affirmation that a human being enjoys a higher degree of ophelimity than another makes no sense: how can something be greater or lesser than another if it is impossible to compare them? How can it be decided that prehistoric man was more or less happy than modern man? Continuing along these lines, how can it be decided that an ant is more or less happy than a man, or a lion more or less happy than a gazelle?” (*Corso [Course]*, Vol. II, p. 51).

“Still, even if these ultimate comparisons are generally avoided, the feelings of men in the same society and, sometimes, of different types of societies are compared every day. Can we, under the pretext that it is not possible to compare the feelings of two separate human beings, admit that this type of reasoning is a misjudgement and a complete illusion? This sort of conclusion goes against common sense and is clearly absurd. It would therefore appear to be a contradiction that needs to be explained”.

Pareto makes an effective analogy with physical sensations evoked by colours, for which “it is true that it is impossible to compare the feelings evoked by a colour in one individual with those felt by someone else”. “And yet” – he continues – “an infinite multitude of actions, even important ones, rest in our society on the conviction that men perceive colour more or less in the same way. The first considers two given individuals; the second, individuals who do not differ too much from a certain average type”. Moving on to the problems of economic science, Pareto warns: “It is necessary to understand well that the phenomena studied by political economy and by social science are general and average phenomena and that absurd results will be obtained if we try to replace them with individual and singular phenomena”.

Going back to the case of ophelimity or subjective utility, he continues: “We now see that there is no contradiction between the affirmation that it is not possible to compare ophelimities enjoyed by two separate human beings and the daily comparisons carried out between the wellbeing of some men and that of others. In fact they are two completely different things. In the first comparison two given individuals are considered; in the second, individuals who do not differ too much from a certain average type”.

“The basis of all the comparisons we make is therefore the assumption that there is a certain ground of common qualities in the people being compared. Later we can take into account the differences between these people; but let’s keep well present in our mind that we always presume the existence of this common ground” (p. 54).

“If it were possible to establish a hierarchical classification of needs, it would be possible to conclude with absolute certainty that those people who can satisfy only the most pressing needs are less fortunate than those who can also satisfy less urgent needs. A classification of this kind can only be established for a certain average type and so we are brought back to the criterion we have already specified (with regard to the comparability of ophelimities).”

With regard to this I will recall another hypothetical position by Pantaleoni, one of the greatest analysers of the hedonistic variable in the economic field, for the confirmation that his thought brings with regard to the assumption of uniformity of variation in the utility curve of the overall income of typical subjects (and families).

It is precisely with regard to the analysis of the comparative effects of the different (direct or indirect) taxes at the same levels – a theory I will deal with later – by analysing family budgets as models of the “modes” of distribution of income among different expenses that he stated (in the essay to be found in *Studi di finanza e di statistica [Finance and statistics studies]*, Zanichelli, 1938):

I) “Family budgets, in their *absolute quantities* and in the *proportional relationships between the same*, reveal *precise movement lines* depending on the variations of prices and incomes, lines that are empirical and that must be so for the purpose of every real diagnosis, but that reflect with a great degree of approximation the law of marginal utilities when we make generalisations”.

[It is necessary to warn that this statement, significant for the inferences deriving from it, is preceded by the explanation of why it applies regardless of the circumstances (age, civil status, sex and social class) and applies to the *type of man* in modern society, taking into account the professional context, residence and family circumstances, and of the difference in levels of incomes, “which is perhaps the most powerful among all of the determining factors of the distribution of income to consumption”]¹³⁴.

II) “The effect of a tax is that of a force that determines a redistribution of income so that, *from what it was, it becomes that which is in the class immediately below it*. Or, if the tax is heavy, it moves to that of an even lower class of income.”

III) Even more important, however, is the link with the mode of variation of marginal utility: “It is necessary (to qualify the proposition in point II) in the first place to remember that we are talking about small variations; if they were great ones, those who experience a significant downward or upward jump in the social scale would not have the psychological experience to ensure that *their utility curves coincide* with those who have been accustomed for some time to a specific income class”.

I wanted to underline the hypothetical admission by Pantaleoni of the presumed coincidence of utility curves of people who are different only in terms of the variation in their income because this assumption legitimises the theoretical possibility of tracing a single utility variation curve with the variation of income, considering different subjects in relation to this representation, when the variations in income are small. The divergences from the theoretical movement are explained by the illustrious author both for significant jumps in income and for other psychological adaptations. The hypothesis, however, is dense with meaning with regard to what is expressed in these pages, even

¹³⁴ I have dealt with the light shed by homogeneous modes of distribution of income to different types of consumption in my early work on the *Crisi dell'imposta personale sul reddito [Impact of personal levies on income]* (Cedam, 1931) to illustrate the logical foundation of a personal and progressive levy on income consumed.

within limitations of degree. The long quotation by Pareto and the further reference to Pantaleoni were not inevitable after Einaudi's explicit statement that the explanation of the progressive tax is not in the remit of economy (financial economy in this particular case), because of the non-comparability of utilities and other, implicit or indirect, similar objections as expressed above.

I want, however, to make reference to the already quoted Pareto, as I did in the 1944 lessons, with regard to the non-measurability of utility in terms of objection to the attempts to find a rational explanation of the distribution mode of taxes in a progressive sense. We read in the *Corso di economia politica [Political economy course]* (vol. I) that we must not confuse two very different issues: that of the existence of a quantity and that of the practical means to measure it. "The distances of Earth from the various stars are quantities whose existence we are certain of. Only some of these distances have been measured, and in a rather imperfect way. We can draw significant consequences from the mere circumstance of the existence of a quantity." In reference to ophelimity and economic phenomena, Pareto observes how "through observation of these it would be possible to *indirectly obtain* values, in the same way as it is possible to deduce the length of light waves from the observation of optical phenomena. Precisely in the same way daily observation confirms the decrease of ophelimities with the increase of the consumed quantity of an asset" (paragraphs 16 and 17).

These latter ones [a cosa si riferisce, "questi ultimi"?] could be references to statistical research projects, such as those attempted by Fisher and R. Frisch to measure the marginal utility of money. These are projects that are not yet satisfactory but which the same Einaudi appeared to trust, in terms of field of observation¹³⁵.

However, it cannot be said that the theory, which is hypothetical, "does not exist" only because there is no way to ascertain if facts correspond to it in any way. Einaudi scolds others – when he finds it useful to demonstrate his own theory (of the double taxation of savings, which I will discuss in Chapter VII) – for the same confusion he also succumbs to, contradicting himself, in the same work (*Miti e paradossi [Myths and paradoxes]*, *op. cit.*). Indeed the real scientific proposition is the one he expresses in the following terms (p. 108): "the inventiveness of a principle is not measured by the immediacy of its application". He states this after telling Stuart Mill's critics off for "roughly confusing the reasoning of the principle with the study of its concrete applications". It is not clear why Einaudi does not think along the same lines with regard to proportional and progressive imposition, as the science has a single methodology: yet he accepts (p. 173) that rational bases recognise the premises of the decreasing utility of wealth, premises that he defines as axiomatic, to the progressiveness of the imposition. However, in contradiction to this, he makes the distribution of the monetary tax dependent on the Salgarian empiric "psychoscopy" to satisfy the principles of equal, minimum and proportional sacrifice.

[It is necessary to keep in mind, occasionally, also to clarify the geometrical and analytical representations of marginal (and total) utility, that the most rationally up-to-date literature in the economic field takes into account the differentiation between *directly measurable quantities*, to which the *cardinal* aspects of numbers can be applied, and *non-directly measurable extents*, to which the *ordinal* aspect of numbers can be applied.

The *utility* of assets and income that represent all of them is considered to be *ordinal*. (Boulding, in *Economic Analysis*, 1948, defines it as "intensive magnitude", as opposed to "extensive" measurements such as length, weight and time, which are directly measurable and in particular capable of being summed up).

It is, however, logically possible to consider a non-directly measurable size as *dependent* from measurable variables. The size (or concept) called utility, which is of an ordinal nature, can be made

¹³⁵ In fact, in *Miti e paradossi della giustizia tributaria [Myths and paradoxes of fiscal justice]* he stated: "Through the observation of a sufficient number of family budgets, differentiated by income class, profession, social origin, residence, and in relation to variations of prices, it might be possible for some future statistician to devise measuring indices, subject to continuous revision, of the psychological reactions to variations of wealth".

For Frisch's work I refer you to "*Economia pura*" [*Pure economy*] of the *Nuova Collana di Economisti [New Economists Series]* and to the critical work, without scepticism, by Vinci in the "Rivista italiana di economia e statistica" [Italian journal of economy and statistics], 1935.

dependent on the measurable quantity, for example, assets or income, according to the function of the total utility:

$$y = f(x)$$

whose derivative $y' = f'(x)$ expresses with marginal utility the mode of variation of utility when the quantity x increases to $ad x + dx$ (for dx tending to zero).

If we consider the area enclosed between the curve of the $f'(x)$ function, the x-axis, the y-axis and the ordinate of a generic point $x = a$, there is the possibility of giving meaning to the defined integral that, in fact, measures the same area, and that, for the interval (a, b) that defines the $f(x)$ function, is generally symbolically expressed with

$$\int_a^b f'(x) dx$$

commonly defined as the sum of the infinite sum of infinitesimal products, which allows us to confer *additional* property to the area, through a process which is, as we can see, *indirect* (of functional dependence of the size of utility, which is *ordinal*, from variations of a directly measurable quantity x , physical asset or monetary income).

With regard to the measurement and logical and hypothetical conception of facts, I want to recall another great economist, Edgeworth, who undertook research precisely in the “mode” of distribution of taxes, to which we will refer later, also based on the hypothesis of decrease and in relation to the marginal utility of income.

Referring to Sax who, with regard to the progressive tax, objected that “it is not possible to obtain a conclusion which must be considered to be proven from unproven premises, it is not possible to derive a real fact from mere hypotheses”, Edgeworth rebutted that “(non ci sono virgolette di chiusura)the character of certainty of a conclusion, while the premises are uncertain, often occurs in that branch of mathematics that, being applied to human relationships, is more strictly affine to pure economy, that is to say, the calculation of probability. In establishing the probability that a given event derives from a certain cause, it is generally necessary to use certain quantities defined *a priori* or antecedent probabilities, of which we know nothing, except that they are not very small (or very large or very different).

With this he stays within the laws of logic that contrast the fear excessively expressed by Einaudi and others regarding the attempt of the assumed hypotheses to give a rational explanation of the progressive tax, with regard to an average or more frequent or probable mode of variation (decrease) of the marginal utility of income, in the study of mass problems, such as the one of the distribution of taxes. Did we not read the admission, in the field of logic, that (JEVONS, *Logica [Logic]*): “We can accept anything as a probable hypothesis, as long as it is compatible with the laws of thought, even though it might be difficult to conceive it or understand it”? The critics of the economic theory on progressive tax would perhaps want a very high probability: however, the same Jevons warns that “an hypothesis that coincides with many facts, laws and other probable hypotheses almost ceases to be an hypothesis, and his great probability makes us consider it as a known fact”.

Here we content ourselves with more or less probable hypotheses in the spirit of the Paretian vision that validates the recourse to the concept of the average type of individual, in those fields where it is necessary to deal with comparisons, *in the judgment of the governing class*, between rich and poor in the distribution of taxes, giving scientific value (demonstration) to the intuitions that have already been mentioned. These are, in themselves, indirect proofs, with universality of consensus with them, of the high probability of the correspondence of the hypotheses of a certain uniformity in the mode of decreasing of utility of wealth with its growing, in a real typical world, from which the same hypothesis is not “entirely” different (Einaudi).

In any case, even those who object to the decrease of utility as the foundation for the progressivity of taxation, ultimately conform to this type of hypothesis. Chapman and Fagan are repeatedly included among these, abroad.

The former objects to divergences from the normal trend law (decrease of marginal utility) that are in part plausible and obvious, with which Fagan agrees. The same Chapman, however, admits that the State must not have too much regard for individuals but accept the same hypothesis that it is essential in such a mainly political doctrine (in the sense that it deals with mass phenomena) and adopt *a form or average type for the entire class*. As can be seen, this is the position of those who object in principle, on the basis of the atomistic differentiation of the individual components of the community! In this regard, see my quoted shifting (in cooperation with Borgatta) of *Principii [Principles]* by Stamp in the *Nuova Collana di Economisti [New Economists Series]*, *op. cit.*

Taylor (*op. cit.*) applies this hypothesis of typical decrease to entire classes of incomes as well as individuals. The negation of this *typical marginal utility curve*, which has been advanced by the already mentioned Fagan (*Recent and contemporary theories of progressive taxation*, Journal of political economy, 1938), is ostensibly defined as empirico-statistical knowledge. This, however, does not authorise the non-logical consequence that, for this reason, the progressive tax can be justified on ethical bases (as Einaudi and De Viti and others saw justified on political bases).

Finally, Cohen Stuart has finely debated the hypothesis of a single utility curve based on the arbitrary premise that “the same percentage of income procures an equal enjoyment to everyone”, by accepting Bernoulli’s correlated hypothesis, debatable but necessary for the scientific and legitimate logical construction, that the degree of utility must be inversely proportional to the increase in income. Having said this, he admits that “regardless of which group or time is chosen”, the utility line can significantly diverge from this position. Stuart Cohen, however, conforms with the hypothesis for a part of the curve, because he believes that “for very large incomes” or “for the last segment” the line “would probably diverge very little from the hypothesis; so little that it is possible to evaluate it as if it coincided with it” (*Contributo alla teoria della imposta progressiva sul reddito [Contribution to theory of the progressive tax on income]*, Bibl. dell’Econ. [Economist Bibliography?/], Series V, Vol. XV, paragraphs 17-20).

V.

IRRATIONAL AND CONTRADICTORY SCEPTICISM LINKED TO THE DENIAL OF A “TYPICAL” DECREASE OF MARGINAL UTILITY OF INCOME, LOGICALLY ASSUMED AS RATIONAL HYPOTHESIS IN THIS COURSE

This concept of the utility curve of average decreasing income or with a more frequent or normal trend relates to provisional or trend results, which are nevertheless meaningful, of other sciences such as sociology or social psychology and also with the term known in Italy, from my shifting of Seligman’s, as the “*Teoria sociale della scienza delle finanze*” [*Social theory of the science of finance*] (in the quoted volume IX of the *Nuova Collana di Economisti [New Economists Series]*).

It is true that, as it is discussed from the position I took in the *Introduction*, there is little credence in these theoretical approaches, which are halfway between intuitions and scientific demonstrations as they claim to substantiate universal generalisations of gnoseologic character. It is, however, impossible to deny a certain orientative value to the uniformities with explicative value, limited in time and space, that in the meantime are derived by the observation of facts, as *mass* phenomena.

We read in the writings by Montessori, the illustrious expert in infant education, what we have known for some time but which, in the specific case, is the result of a long period of observation. That is to say, that what we know about all living things, “that the individual cannot be considered outside the context of his environment”, is all the more valid for psychological life as “its content, as the means of man’s psychological self-experience, is an essential part of him: it is part of the individual himself. And yet we all know that the individual, not his environment, has a life of his own”.

With regard to our problem, however, it is interesting to consider the literature dealing with the *group mind* or *collective mentality* in the field of social psychology or social psychobiology, in

terms of which “it is indisputable that individuals are influenced in their pleasures, objectives, modes and morals by the social group in which they happen to be born or to which they belong in their life”. There are many limitations and exceptions.

Observing a collective organisation with an individualistic mentality which denies that it is dealing with unnoticeable and intangible forces is an exact statement. Denying the problem, however, does not mean resolving it. And in the meantime the ever more frequently reached conclusion of these studies is that, regardless of the individuals who make up the psychological group, however similar or dissimilar are their way of living, their occupations, their respective characters, their intelligence, the fact that they have come together as groups marks them with a type of collective mentality that makes them feel, think and behave in a way which is completely different from the way each individual would feel, think and act in isolation.

This is what Le Bon thinks. For this author, as for MacDougall, Freud, Tarde, etc., and all who deal with collective or group mentality and the influence of instinct, reflex action, imitation, suggestion, sympathy, etc., I refer to J.F. Brown’s bibliography (*Psychology and the social order*, McGraw Book Company, New York, 1936)¹³⁶.

Seligman must have tapped into this type of theoretical treatises, which are in my view devoid of a satisfactory quantitative indication of the modification of pleasures, to use Pareto’s synthetic expression, in his “*Teoria sociale della scienza delle finanze*” [*Social theory of the science of finance*]. What is, however, interesting for the purposes of orientation for readers and students of this subject is that Seligman’s statements, which are on the other hand plausible or very probably close to reality (and not “entirely” apart from the single or collective curve or marginal utility, as Einaudi suggests), have been totally supported by Fasiani in the same (first) volume of the *Principii [Principles]*, a few pages (12) after having *a priori* discredited (9) the “hordes of writers who will feel moved by the idea of a progressive tax and who did their utmost to search a scientific principle that” – in his view – “did not exist and does not exist”. He also refers that “still today finance treatises are full of demonstrations based on the most arbitrary interpretations of the Gossen law” (on the decrease of utility).

Fasiani accepts Seligman’s following concepts and their subsequent uniformities (which of course in these pages are viewed as probable):

I) The action of each individual is not only influenced by the existence of other members of the group, but absorbed by the action of the group. The individual does not now act independently but in unison with others. His personal feelings, as an isolated being, are now influenced by his feelings as a member of the group. His entire psychology has changed. He no longer does anything he would have done as an isolated individual. What he now does as a member of the group is something

¹³⁶ It is useful to remember – in spite of the criticism levelled at Pareto for the sociological references to events of his time – the current testimony, even if linked to news reports, as the incidental circumstance that led to its expression (with regard to an inquest on trends in world prices, of which he wrote about in the newspaper *Tempo*, Rome, on 27 February 1951), by an expert of, one could say, of collective psychology or sociology, such as Prof. Prezzolini, who teaches this very same social science at the Columbia University in New York. Dealing with the average cost of life in the United States, on the basis of family budgets, he reflects that “difference between the ways of life of the rich and the poor is not as perceptible as it is in Europe, and this is not so much because there are no rich or poor people but because the life of the rich is not very different in terms of taste, in essential things, from that of the middle class and that of the middle class is not very different from that of the poor. The rich person will pay for a cruise or travel to Europe that the middle class person cannot afford; and the middle class person will pay for an evening in a night club that the poor person cannot have. The way they eat and spend for common needs, however, is not very different. Truman’s food and reading materials are not that superior to those of a common clerk. Therefore the sum of the average family expenditure in the United States reflects more realistically the way in which the majority live”.

Consider the correlation that Pantaleoni has established in a braver way than other economists between the trend in budget and the trend in utility, and it can be seen how much common ground, as Pareto would say, there is in terms of hedonistic appreciations and the assumption of a uniform utility of income which tends to decrease with growing positive increments available to physical people, which results entirely supported and not at all “entirely” different from reality.

different from what he would have done if there had never been a group ... (I leave out other concepts for brevity of reference).

II) As different individual people become part of a group that satisfies common needs, the separate needs of the individuals are hidden. However, if the personal feelings of individuals are absorbed or changed in the very different psychology of the member of the group, it is practically indifferent that we speak of the existence of the group as such or of the existence of group feelings of the individuals, considered separately from their separate feelings. The important point is that the member feels and acts in a different way from the individual who does not belong to any group or from the isolated individual ... We have, in other words, not just a sum of isolated individuals, but a transformation of isolated individuals in members of the group, that is to say, something more than the sum of its parts.

After Fasiani's unconditional agreement with these concepts by Seligman, it is possible to explain Fasiani's attitude in the sense of the admission (*Principii [Principles]*) by the same Fasiani of: a) that the possibility of constructing a (single) curve that "represent[s] the utility of average subjects in the various classes can roughly represent the evaluations of a metaphysical person that we can define as the *taxpayer*, gifted with the average sensitivity of subjects representative of the various classes of beneficiaries of income"; b) of the existence of "good reasons to believe that in the judgment of the elected class, the curve so constructed has a decreasing trend". On the other hand, however, it cannot be explained of Fasiani: c) the belief that the procedure used to trace the (single) curve of decreasing utility of income "is not scientifically legitimate and not advisable in the treatment of problems of pure science". On this point (c) Fasiani's thought is not only in contradiction with what he admits in points (a) and (b), but he confirms this contradiction just now identified with the contents of pages 9 and 12 of Vol. I.

Indeed, the error or abuse, in terms of probability of movement from the hypothesis of the collective or group mentality, welcomed by Fasiani who supports Seligman's ideas without any criticism, is generically expected in the assumption of hypotheses approximate to but in contrast with concrete evidence, whose typically social reality he has presented that admits (p. 69) as *normal* this behaviour of men. The "personality" transposition the illustrious author discusses does not appear to be in contrast with the assumptions he has derived from Seligman and made his own. And when he legitimises it in the rough calculation of the elected class, a calculation that in fact this science tries to explain – and in relation to which I refer to the type of reasoning adopted by Pareto on the maximum utility *for* the community – he adopts an hypothesis that does not differ from that on which Cohen Stuart and many other authors have set reasonings of pure theory.

What precedes explains how the individualistic, critico-sceptic mental position of authors who reason, so that we understand each other, like De Vito De Marco, Einaudi, Barone and their followers, does not appear to be suitable to be set in the vision that gives life to all sciences in current research in the field of thought.

Many have quoted MacCulloch, who put forward, to those who tended to abandon proportional taxation in favour of progressive taxation, on the basis of the decrease in non-measurable marginal utility, that this was like "going to sea without bearings or a compass". The response to this was that it is sufficient for the theory that marginal utility *typically* decreases.

Above all, however, the responses have included statements such as: I) that of Cohen Stuart: "it is an error to assume proportion; it is possible to search for a progression scale for which it can be said that its assumption is a lesser error"; II) that of Taylor (who echoes other current experts) according to whose vision "the choice between proportional and progressive taxation is (therefore) a choice between certain injustice and uncertain justice". And terms of the probability that the hypothesis reflects facts to be explained, from an economic point of view, this problem continues to be treated on the basis of *variable utility*.

On the other hand, the fact that nearly all experts have addressed this is proof that research belongs with pure science. It is something else for some to come to a conclusion with an atomistic vision in a negative sense, and for some others to conclude in a positive sense about the logic legitimacy and the theoretical inventiveness of the introduction of the marginal utility variable with the uniformity (decrease), derived from pure economy, which characterises it with regard to assets

and money – in the explanation of the modes of distribution of general taxes charged to the community or member groups within it – with Pantaleonian and, even more so, with Paretian criteria in their approach to mass phenomena¹³⁷.

¹³⁷ To give an idea of what would be the scientific position of a passive observer of facts to whom the logical legitimacy of a probable hypothesis on the mode to vary the sacrifices linked, in a hedonistic setting, to the payment of tributes, I will present the paradoxical vision of a society in which the current and dominant *ethics* are the basis of the policy of distribution of levies between rich and poor. I am referring to the humorous and sarcastic vision of men dressed up as penguins in the society described by A. France in *Ile des pingouins [Penguin Island]* (Chapter V), and with a preconceived anticonfessional theory. The dialogues reported by France feel, even though in different terms, rather similar to rallies and parliaments in human societies:

“And old Maël then said:

– Now that we have a register of all inhabitants, it would be a good idea, dear Bulloch, to charge an equitable levy to take care of public expenditure and maintenance of the abbey. So, my sons, gather around the Alca Elders and we will agree a levy with them.

The Elders were summoned and thirty of them gathered in the wood cloister, under the great sycamore. They had founded the first States of Pinguinia. Three quarters of them were large farmers from Surelle and Clange. Greatauk, as the most noble amongst the Penguins, sat on the higher rock.

The venerable Maël took his place among his religious brothers and said:

- Sons, when he pleases, God gives men riches and then takes them back. Now, I have gathered you here to agree the levies to be charged to the people for the purpose of taking care of public expenditure and the support of the religious order. I think that these contributions should be proportional to the wealth of each one. Therefore who has one hundred oxen will give ten; who has only ten will give one.

When the holy man spoke, Morio, a farmer in Anis-sur-Clange, one of the richest Penguins, stood up and spoke: Maël, my father, I think it is right that everyone should contribute to public expenditure and the Church. As far as I am concerned, I am ready to deprive myself of all that I have in the interest of my brother Penguins and, if necessary, I would gladly give the shirt off my back. All the elders are prepared, like I am, to sacrifice their assets; we cannot doubt their absolute devotion to their country and religion. It is therefore necessary to consider only the public good and do what we must. What we must now do, father, what it asks of us, is not to ask too much of those who own much, because otherwise the rich will be less rich and the poor poorer. The poor live on the assets of the rich. It is for this reason that these assets are sacred. Do not touch them: it would be an unnecessary unkindness. You would not get much by taking from the rich because they are not very numerous; and on the other hand you would deprive yourselves of every resource, throwing the country into misery. On the other hand, if you ask a little help of every inhabitant, without reference to his wealth, you will gather enough for the public needs, and you will not need to look into the wealth of citizens, who will view any such investigation as an unbearable oppression. By charging everyone lightly and in the same way, you will save the poor because you will leave them with the wealth of the rich. How could a levy proportional to wealth be possible? Yesterday I had two hundred oxen. Today I have sixty. Tomorrow I might have one hundred. Clunic has three cows, but they are thin. Nicclu has two, but they are fat ones. Of Clunic and Nicclu, who is the richer? The indices of wealth deceive us. What is certain is that we all eat and drink. Charge a levy on what people use. This would be wisdom and justice.

So spoke Morio, to the cheers of the Elders.

– We should engrave this speech on bronze tablets, shouted brother Bulloch. It should be done for the sake of the future. In millennia to come the best of Penguins will speak in the same manner.

The elders were still cheering when Greatauk, his hand on the hilt of the sword, briefly said:

– As I am a nobleman, I will not contribute because contributing is ignoble. Contributing is for lowlife.

And after this statement, the Elders went their own ways in silence.

The academic should cross his arms and not explain matters of tributary equality, by saying that it is all to do with politics and ethics, and not explain the sophistry and the irrationality that is hidden behind the settings in questions in laws and political motivations: that is to say, say nothing of the objective burden of tributes, which can only be clarified with the introduction of the utilitarian variable. Studies in this field however continue, even with relatively recent dedicated monographies such as the one quoted by L. Rossi (1932) or the one by Kovero: *Die prinzipien der Wertproportionalität unter Wertgleichheit in der Besteuerung* (Helsinki, 1938) and current writings and essays.

VI.

ANALYSIS OF THE PRINCIPLES OF SACRIFICE: a) EQUAL, b) PROPORTIONAL,
 c) COLLECTIVE MINIMUM

It is necessary to go back to the criterion of equality, expressed by politicians (legislators), moralists, sociologists and preceptists, for the introduction of (subjective) variable utility in the interpretations of the presumed calculation by the governing class for the explanation of the “modes” of distributing general taxes used to fund the costs of indivisible public services.

A) Going back to a literary interpretation in the old constitutional papers and the standards proposed in precept form by the first fixers of economic science, equality can be expressed in objective or monetary terms, in the sense that each member of the community contributes in proportion to what they have or in relation to their contributive capacity, represented by their wealth in the form of income or assets.

The principle has been defined as *equality of the monetary relationship between the income surrendered to the public body and the overall private income* (or total patrimony), for personal or general taxes. The term “overall” does not apply to real taxes on individual incomes, patrimony of a single type, etc.

Cohen Stuart conveniently said of the principle of contributive capacity that it “does not give a measure for the distribution of the tax, but rather it is useful to determine the object of the tax”.

Indeed, with regard to the numerical examples presented above, from which the objective or monetary equality of tributary relationships can be deduced, there is the opposition of a vast array of intuitions that state that equal sacrifices of utility or enjoyment with the same level of proportional tributary burden that, as we have seen from the *Introduction* to this course, we have represented with the relationship:

$$tr$$

(where t is the tribute percentage, and r the income to which it is applied).

Going back, for example, to Cohen Stuart, he suggests that “the measure of distribution” (in terms of equality) “is given on the other hand by the theory of sacrifice”. The principle therefore becomes: *taxation according to contributive capacity, such that an equality in terms of sacrifice is derived from it.*

B) To be able to give a demonstration of equality, as it is presumed to be considered by the legislator, in subjective terms (sacrifices of utility in the context of general contribution) it is necessary, as it has been seen, to introduce the utilitarian variable in the solution of *mass* problems such as the tributary one. It is necessary to hypothesise, for this purpose, a utility curve that some consider to be *average* (that some others would refer to as with a more frequent trend in the sense of decrease) for individuals who differ mainly with regard to the overall income at their disposal, who live in a determined territory, at a certain period in time (to simplify, leaving aside circumstances such as age, sex, different family composition, etc.).

Indeed, rather than average, to avoid thinking in terms of complex mathematical calculations for the governing class, in terms of definition of the utility expressed in a collective curve, it is best to concede the concept of a *more frequent, normal, etc., trend*, in the sense that the individual manifestations of the phenomenon become more numerous around a certain value (trend, with more or less regular variations from a given movement).

The obvious principle of political economy that is by now adopted as an axiom, of the *decrease* of marginal utility with the increase of individual physical goods, or of the money that instrumentally represents all of them, is therefore extended to a utility curve that is representative of the most frequent or normal reactions of the subject considered, in the judgment of the governing class which makes homogeneous and typical all the utilitarian evaluations of individuals and groups.

Cohen Stuart (to whom I refer because he marked a milestone, as we will see, in the elucidation of the thought and in the demonstration of the intuitions that have been dominant for

centuries) justifies the hypothesis that can be arbitrarily traced, starting from the Bernoullian one (according to which the degree of utility must be inversely proportional to the total income).

Discussing the views of Pierson, Treub, Cort van den Linden, Cohen Stuart justifies the hypothesis in probabilistic terms, in the sense that *the last segment* (of the line), as we will see, for very large incomes will “probably” diverge little from the hypothesis: so that it is possible to presume that it coincides with it.

The widespread representation of the intuitions and of the hypothetical admissions of the theoreticians of the previous chapters, in terms of pleasures, preferences, utility and its sacrifice, allows the consideration of the hypothesis of a decreasing uniform utility curve for several individuals who are part of a group, with relevant common ground. This occurs to the point that, to quote works that have reviewed or have been published (for the first time) these days, Dalton, in considering the hypothesis that the relationship between income and economic wellbeing is the same for all taxpayers, notes: “some economists, especially in the United Kingdom, those belonging to the London individualistic school, have highlighted that this is only a hypothesis – no one who has used it has claimed it to be anything more – and have considered it *unscientific and untenable*. But it is a hypothesis (or assumption) that justice demands and politicians and administrators must abide by, by and large, in civilised countries. *Neither is it so far from reality as some critics suggest* (my italics). Many of us, with given income levels, are much more similar to each other – in our needs and the normal modes of behaviour and in the reactions to variations of income – than theoreticians seem to believe” (*Public finance*, 1949, p. 92).

Similarly F. Vinci, already in dispute with Ragnar Frisch in 1935, did not declare himself “anti-utilitarian” in criticising (especially on a *matter of principle*) the results of the statistical investigation based on family budgets in the United States. The marginal utility curve of money as a decreasing function of income represented “an empirical mass behaviour phenomenon that has a significant importance and that requires an explanation”: R. Frisch thought it plausible only in terms of utility.

In 1950, in discussing the quantitative differentiation of sums individually collected for indivisible expenditure, Vinci made the case for a general tax on the income from each unit of consumption (individual as in taxpayer), “inspired to equalise the great tributary sacrifice of the poor to the small one of the rich”. Therefore, referring to this comparison, he traced a single growing curve for *total* utility, to explain the progressive tax on the basis of equality criteria and proportionality of sacrifices. He did so even while he warned that “while it is possible to state that the value of general gratification tends to grow slowly with the increase of total income, this property cannot be based on rough observations expressed by those who have little; whichever way this issue is considered, however, it must be recognised that the comparison would be carried out by the representative bodies of the individualistic State, which would choose general criteria to implement in the collection of taxes to apply in relation to the magnitude of incomes”. Now Vinci, a great statistician and economist – a coincidence of interesting positions in this field, that has seen Fisher and Frisch undertake statistical research to measure the marginal utility of money – uses a single curve for both the rich and the poor in *Istituzioni di economia [Economy institutions]*, (Zuffi, Bologna, 1950, pp. 141-145).

We will refer later to a growing collective total utility curve, such as the one that Vinci used, to determine some rational tributary collections on the basis of the principles considered here.

First of all, however, a decreasing *marginal* utility curve is used to demonstrate, with Cohen Stuart, that the hypothesised uniformity of the decrease of marginal utility of monetary income, does not *necessarily lead to the abandonment of the tributary constraint of type tr to pass to a tributary constraint of type ar* (already indicated in the *Introduction* and that, for greater symbolic homogeneity, could be expressed with ar^k – where i indicates the tax, r the income and a and h two positive constants that confer progressivity to the tax).

C) The real scientific demonstration, once the legitimacy of the hypothesis is admitted, dense with historical content and not at all in contrast with the reality of the presumed mode of reasoning of the governing class of which, in fact, it constitutes a credible representation, *more or less*, comes after the definition of justice, interpreted in the sense of equality, as a criterion for the distribution between

the rich and the poor and generally between different types of beneficiaries of income, of the general burden of the tax to meet the cost of indivisible services.

Let's suppose that moralists and politicians have contributed to the enunciation of a criterion or principle of justice, in the sense that each taxpayer must pay the tax so that the absolute value of the sacrificed utility is: I) *equal* for each taxpayer; II) or *disproportional to the total utility* of the relative income. We also symbolically qualify these criteria that are psychologically defined as: I) *equality* and II) *proportionality of sacrifice*, and geometrically as I) *the difference* and II) *the ratio of the areas*.

The scientific question Cohen Stuart addressed at the time is as follows: is it sufficient that the single curve of the utility of monetary income, starting from a certain point, decreases to deduce in any case the logical legitimacy of replacing the tributary constraint tr with the tributary constraint of type ar^h (or at' as previously indicated), that is to say, to pass from a proportional tax to a progressive one or more than proportional when the monetary income available to subjects, as taxpayers, increases?

I) To demonstrate how the introduction of the utility variable, with the obvious property of the trend to decrease at the margin beyond a certain point, as the income available to physical people increases, does not in itself imply the progressivity of the rate. The hypothesis, which can represent a minute case, of a utility curve that has the shape of an *equilateral or rectangular hyperbole* has been formulated. (It is known that for this the product of the abscissa and the ordinate is constant at any point; that is to say, it is always geometrically equivalent to the same corresponding total surface).

Now this curve, shaped as an equilateral hyperbole, is traced in reference to its asymptotes. This is considered the simplest mathematical expression of the decrease of marginal utility with the increase in income, according to Bernoulli's hypothesis (degree of utility inversely proportional to assets or income).

Let's presume income OR , that is, half of income OR' . If we imagine the collection of a proportional tax RT (for example 20%) of the quantity (represented by the x-axis) OR , this leads to a sacrifice of utility represented by the area $TRVV'$ (shaded).



Figura 4.

Because of the hypothesised characteristics of the curve (equilateral hyperbole) this area must result in the mathematical equivalent to that determined by collecting the proportional quantity $T'R'$ from income OR' , to which corresponds the shaded area $T'R'SS'$, which expresses the total utility sacrificed for the payment of the same proportion (20%) of collection of income, in measure of $T'R'$, as it has been stated.

In symbols this can be expressed for the defined equilateral hyperbole with the equivalence of the defined integrals (whose extremes of the intervals TR and $T'R'$ are qualified in the way indicated)

$$\int_T^R f'(x)dx = \int_{T'}^{R'} f'(x)dx \quad \text{--- [I]}$$

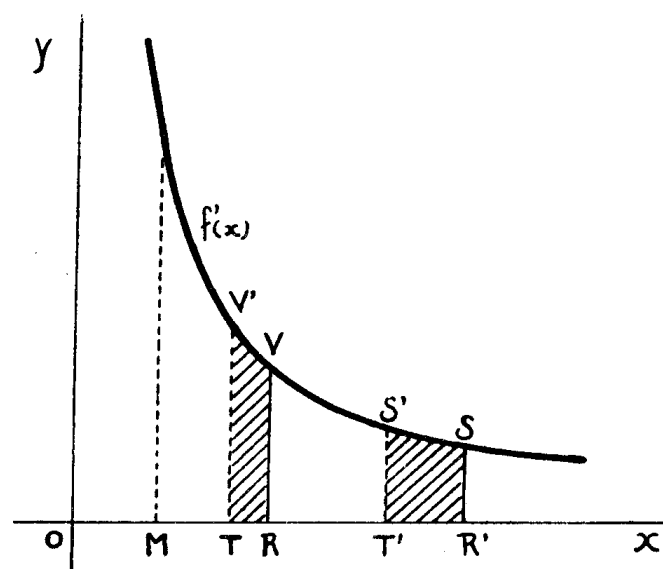
the equivalence of the sacrifice caused by the proportional tax. This is precisely because the shape of the Bernoullian curve does not justify the logical necessity of the progressive tax to realise the ideal of justice of equality of sacrifices. P is sufficient to tangibly translate this political, moral, etc., ideal into proportional imposition.

II) An analogous demonstration can be given with regard to the realisation of the principle of the *proportional sacrifice compatibly with proportional tax*.

In this case it is necessary to hypothesise, for gnoseological reasons, a type of curve with the following properties: for each point of the curve the product of abscissa and of the ordinate forms the *same area of total surface* included between the ordinate, the coordinates and the utility curve, on the left of the point.

Of course, examples of straight line occurrences are easier to identify, as in the case of the line parallel to the x-axis, where the product of the coordinates coincides, for every point of the line, with the surface representing the total utility. I will ignore the cases of straight lines and growing curves, as they are not compatible with the most frequent mode of variation of marginal utility, although they do have the geometrical property described above.

Cohen Stuart has used *decreasing curves* that have this property and allow us to demonstrate that it is not necessary to have progressivity of tax rates to obtain proportionality of sacrifice of utility, with regard to collection of tax from the overall income.

The decreasing curve of type *PQ*, also asymptotic to Cartesian axes, to which it tends to get close towards infinity, has the property, precisely, that the surface included between the ordinate corresponding to a point (for example *B*), the axes and the hypothesised curve, that is to say *OABPy*, remains consistently equal to double the product of the abscissa by the ordinate, that in the example is *OABD*. In this case the



Figura 5.

proportional tax, measured on the x-axis, results in a *sacrifice of proportional utility*.

Given this property, for example with proportional tax *AT* (40%), a sacrifice of utility can be determined, indicated by the geometrical area *TABV*, which has the same ratio to *OABPy* as the sacrifice determined, for example by tax *RN* (40%) to income *OR* and is indicated by the area *NRSV'*

as a ratio to $ORSPy$, which represents the total utility corresponding to OR (as $OABPy$ corresponds to the total utility of OA).

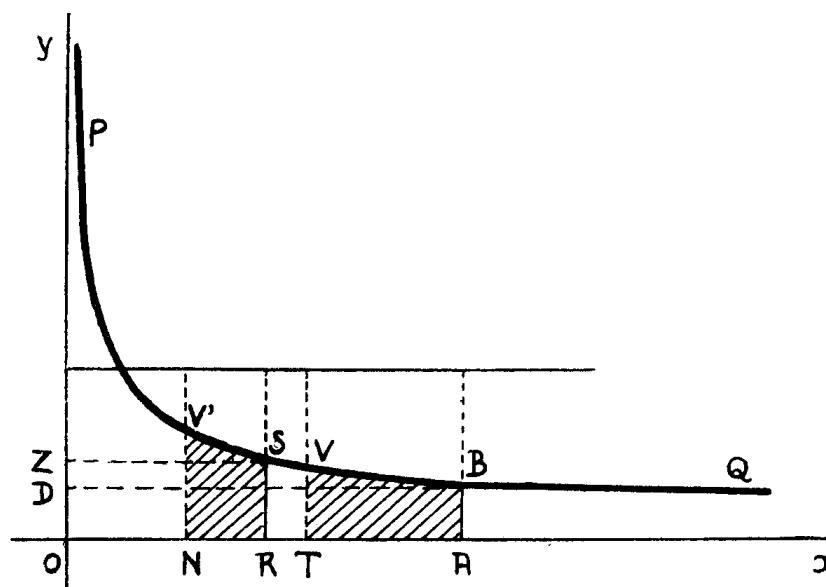
In conclusion, in the cases sketched for I and II, the proportional tax is sufficient (even though there is decreasing utility of income for the taxpayers, as considered hypothetically by the governing class) and the progressive tax with increasing income is not necessary to achieve the principle of equality of sacrifice or that of proportionality of the sacrifice determined by the payment of the tax to the public body.

III) Now it is possible to demonstrate how the logical possibility of achieving equality of sacrifices, between two typical taxpayers, can be derived from the growing trend of the utility curve, through a non-progressive and not even a proportional tax but rather a *regressive* tax, that is to say, a tax that is *less than proportional*.

(The same could be demonstrated for the criterion of proportionality of sacrifices).



Figura 6.

Let's suppose a utility curve that moves away from an equilateral hyperbole (to assume the type described below) in the sense that the left branch rises less strongly in respect of a point of the rectangular hyperbole referred to its asymptotes (the dotted line in the figure), while on the left of this point the rhythm or *rate* of decrease of the curve (or of the marginal utility) decreases to the point of becoming insignificant and null (with the line of utility becoming a straight line essentially parallel to the x-axis).

In this hypothesis (that cannot be said to be very probable in terms of correspondence to the psychological reactions of taxpayers) even a proportional tax, as it is immediately apparent, would cause a violation of the principle of equality of sacrifices caused by the contribution of the general tax. So that this ideal of justice can be rationally achieved in the economic field, it is necessary for the tax to be neither progressive nor proportional, because this latter would indicate an income OR' double that of OR a sacrifice represented by the area $T'R'SS'$ greater than $TRVV'$. To make the sacrifices (and therefore the areas in the geometrical figure) equal, it is necessary that the tax is not, in the second case, $R'T'$ double RT , but less, that is to say Rt such as, in fact, to equalise the two areas. Generally speaking, the legislator that has hypothesised such a decrease of marginal utility must coherently demand taxes that are decreasing percentages of the growing income.

IV) Given this, I make the hypothesis of a decreasing utility curve with such an inclination with respect to the axes as to require, in any case, a progressive tax to correspond rationally to the principles of equal and proportional sacrifice. I will consider the theoretical characteristics of this, in the symbolic-analytical and geometrical representations.

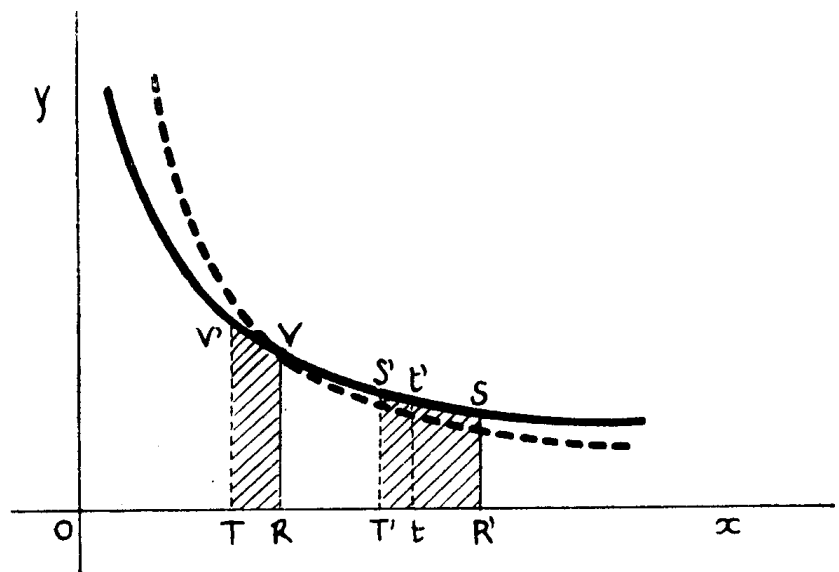
Let's presume, indeed, a utility curve that decreases according to UU' , which moves away from the hypothesis of the curves considered up to now. In this hypothesis the principle of equal sacrifice requires the tax to be progressive.

In analytical terms this principle can be expressed with:

$$\int_{r-s}^r f(x)dx = c \quad \text{--- [II]}$$

where r = the various incomes;

s = the tax;

$f(x)$ = the marginal utility of the generic quantity that, in the specific case, *corresponds* to income r , so that $f(x) = f(r)$

c = constant.

This means that the total utility corresponding to the collection of the tax must be constant (c), that is to say, of equal quantities for different taxpayers. This principle is also defined as *differences of the areas*. As can be inferred by observing the geometrical figure, the difference of the areas under the marginal income utility curve ($R'SUM - RVUM$) before the collection of the tax and the difference of the areas obtained after the collection of the tax (respectively $R't$ and RT , which realise the equality of sacrifice), that is to say ($tsUM - TVUM$), is an *income dependent constant*.

Given the hypothesis that the tax should be progressive, fig. 7 allows us to make the following considerations.

Given that (always without considering the first part of the x-axis, which represents the minimum income for life or to meet the normal requirements of life and, therefore, the corresponding representation of the utility that is considered indefinite), the sum RT is collected from the first taxpayer and proportionally the sum $R'T'$ from the second taxpayer, who has an income twice as large, a greater sacrifice will be caused to the first taxpayer, as the area $TRVV'$ is greater than the area $T'R'SS'$. To make these equal it will be necessary to collect from the second subject or typical taxpayer, as a hedonist, a more than proportional monetary sum and, in the case given by the example, greater than $R'T'$ and tending to $R't$, such as to determine a sacrifice, for this typical subject, measured by $tR'Ss = TRVV'$, which measures the sacrifice of the first typical taxpayer.

[It is a necessary and sufficient condition for the tax to be progressive (as deduced by the curve in fig. 7) that, when the principle of the difference of the areas is adopted, the measure of the variation of marginal utility $f(r)$ for small variations of r is greater than the unit].

To determine *immediately*, using the graphical method, the quantity of the collection that makes sacrifices equal, it is possible to use the representation of the problem in terms of *total utility* (in fig. 8, the shaded curve indicates, precisely, the constant size corresponding to the part of the total utility sacrificed through the imposition).

Let OR be the income from which the tax RT is collected from a typical relatively poor taxpayer that has determined the sacrifice of utility uu' . It will be necessary to collect a quantity of income, represented on the x-axis by RT' from the greater income OR' such as to make uu' equal to vv' : that is to say, the same quantity of total utility must be sacrificed.

I now consider the criticism addressed to this principle (I mean the only essential one when we accept the preceding hypotheses and we think in terms of typical taxpayers and not, atomistically, of individual taxpayers with different utilitarian evaluations and with different utility curves: in that case the traditional objection of non-comparability and non-measurability of utility would apply).

Indeed, with the principle of the difference of areas, we remove a constant (utility corresponding to the amount of income collected with the tax) from *different quantities* of total utility. And this, as we can deduce also from the geometrical representation, increases with the increase in overall income available to taxpayers.



Figura 7.



Figura 8.

In other words, the quantity of utility taken from the rich and from the poor is the same, where this represents a *relatively smaller* quantity for the rich man, that is to say, in relation to total utility.

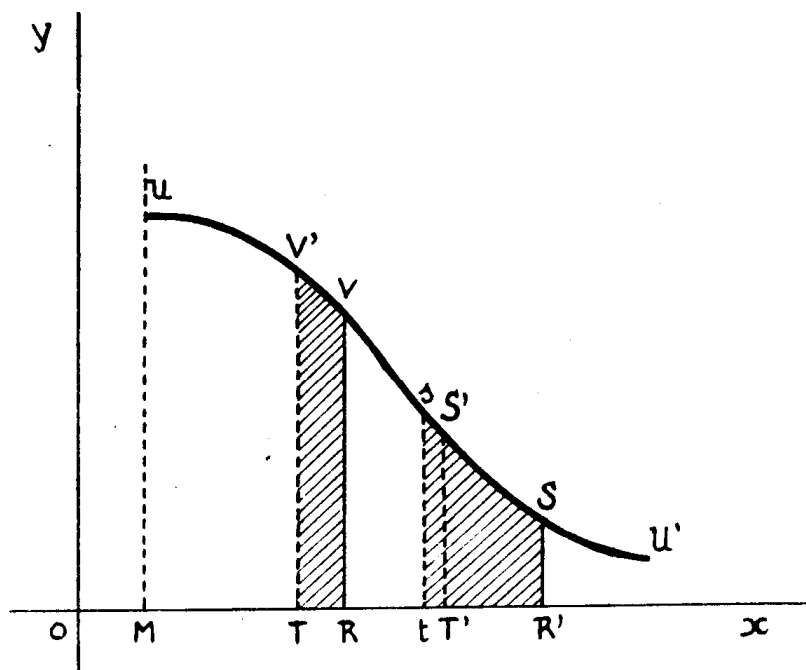
Or, even in those cases in which there is progressivity of imposition in terms of *monetary income collected*, there would be *regressivity* in terms of the utility ceded or sacrificed in relation to the total utility available to the poor and the rich.

V) To remedy this imperfect mode of achieving equality in subjective terms or in terms of sacrifice, the concept of justice in the sense of *equality of proportion* has been defined, in which the utility sacrificed remains in proportion to the total utility of the individual taxpayers, who are typically compared here in consideration of the different quantities of income at their disposal.

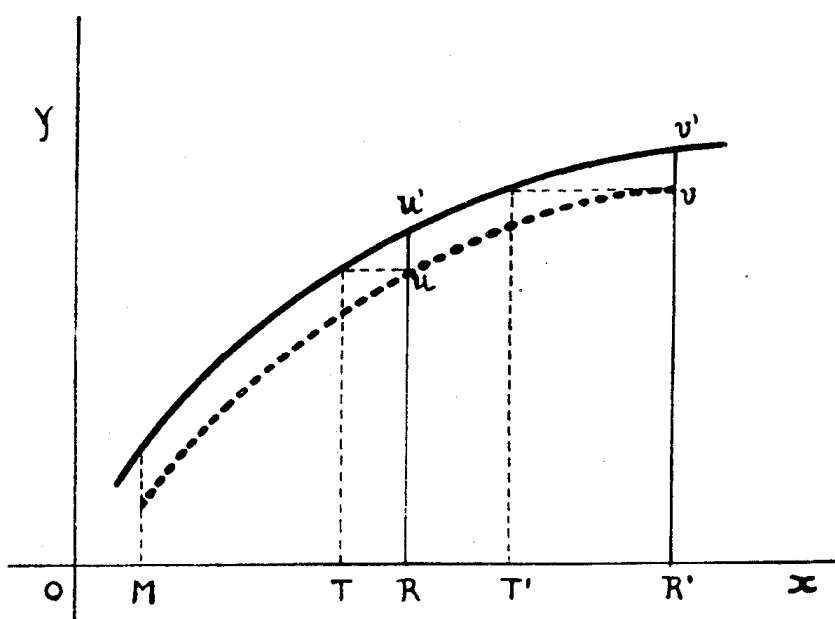
According to the principle of proportionality of sacrifice (geometrically also defined as *areas ratio*), each taxpayer must cede *not* the same absolute quantity of total utility (as in the preceding case of equal sacrifice) but, in addition to personal general imposition, each taxpayer must experience the same *percentage* loss of total utility at his disposal and corresponding to the overall income he enjoyed before the introduction of the tax.

To give a vision of equality of the *ratios* between the areas that represent total utilities and the utilities deducted by the tax, please make reference to a graphical representation analogous to that in fig. 7. Consider in this the ratio between the areas $TRVV'$ and $MRVU$ on the one hand, and that between $tR'Ss$ and $MR'SU$ on the other, respectively representative of the utilities lost with the payment of the tax and the utilities enjoyed before.

Even in the case of the principle of proportional sacrifice, it is possible to determine *immediately* the *quantum* of the tax (for the progressive hypothesis) that makes equal the ratios between the utility ceded with the payment of the tax and total utility by recurring to a geometrical demonstration, using the *total utility curve*.

Let's describe the curve as representing the mode of variation of total utility with the increase of income on the x-axis; that is to say, let's represent $y = f(x)$. From points R and R' of the x-axis indicating, respectively, the size of incomes OR , let's presume of the rich, and OR' of the poor, let's draw perpendicular lines up to until we reach the corresponding points U and U' on the curve of total utility. Let's draw a straight line through these points which will meet the x-axis in point S , so obtaining two similar triangles RUS and $R'U'S$ (A parallel straight line on one side of the triangle, which meets the other two, determines a triangle similar to the given one).

Let $R'I$ be the tax on income OR' , of the typical poor subject, and IT the total utility of residual income OI . PU' then clearly represents the utility sacrificed for the tax.

For the determination of the equality of ratios between the utilities proportionally sacrificed by the two taxpayers, it is necessary to determine the tax (which will result in being progressive, given the hypothesised curve) that must be charged to the typical (rich) taxpayer with an income OR , to which corresponds the total utility RU , compatibly with the principle of justice which is presumed to be applied by the politician, moralist, etc., and accepted by the legislator (and by the academic, as hypothesis).

From the vertex S , common to the traced triangles, draw a straight line passing through point P and which determines segment UV (which, as we will see, is the utility sacrificed with the payment of the tax) on UR , which represents the total utility for the (rich) taxpayer on income OR .



Figura 9.

From point V trace a line parallel to the x-axis to touch the curve of total utility at point Q . The perpendicular line to the x-axis from point Q determines point I' and the x-axis segment $I'R$, which represents the *relative greater tax* (that is to say, with respect to IR' charged to the less wealthy) that must be paid by the (rich) taxpayer on income OR , so as to achieve proportionality of the sacrifices caused by the two tax rates: in other words $U'P : U'R' = UV : UR$.

Generally speaking, in the case of the application or interpretation of the principle of equal sacrifice, the resulting tax is progressive. In the case of the proportional principle progressivity must result from increases in higher rates. In other words, if the principle of the difference of the areas results in a progressive tax, this must all the more be the case when the principle of ratio of the areas is adopted.

This second expression (which can more explicitly tell us about the equality of the ratio between the areas representative of the utility owned and ceded in relation of the tax event) can be translated into symbols by making reference to the geometrical figure (no. 7) and presuming the equality of ratios between areas, as indicated above. The above mentioned definition of justice is then expressed with the equality of the integrals defined by

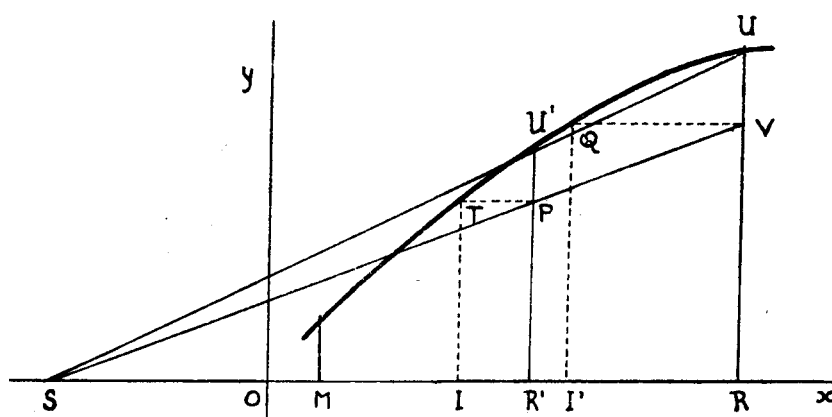
$$\int_{r-s}^r f(x)dx = c \int_r^{\bar{r}} f(x)dx \quad \text{--- [III]}$$

where $f(x)$ is the function of the marginal utility of income; dx is the infinitesimal variation of income; $(r-s)$ is the income net of the tax; c is a constant independent of r that appears as a coefficient of proportionality; \bar{r} an income higher than r_0 (considering r_0 the minimum for existence, in proximity of which the marginal utility of income is *presumed to be infinite*; it would be best to call it *indefinite*).

[A necessary and sufficient condition for the infinitesimal tax to be progressive at every point of a given level of income – when the principle of justice represented by the ratio of areas has been adopted – is that, at every interval, the flexibility of the marginal utility of monetary income $w(r)$ (defined as the increased relative measure of the variations of $w(r)$ corresponding to small increments of (r) of the ratio between rectangular utility raw and total utility W , is greater than I. Through R. Frisch symbols, that is to say, this is:

$$\frac{dw(r)}{dr} \cdot \frac{r}{w(r)} + \frac{rw}{W} > 1.$$

Of course, as I have already mentioned, it is possible to use another hypothesis, very probably representative of a limit case, which presumes that the trend of the line expressing the mode of variation of marginal utility is a horizontal line, parallel to the x-axis. That is to say, the marginal utility does not decrease with increasing income.

In this limit case the principle of proportional sacrifice justifies the proportional tax, as it can be gathered, in the blink of an eye, by considering the geometrical figure that can be easily drawn.

VI) It is necessary to underline the importance of the symbol r , in the analytical expression of the principle of proportional sacrifice.

Indeed, if the utility of the minimal income for existence or tending to r_0 were also to be considered, as we have said before, the utility of OR would become infinitely great (figure no. 7). As the utility of income (of the rich) OR' is equal to that of income OR plus the utility of income RR , represented by the area $RR'SV$, if the utility of OR , because we consider also part $OM = \bar{r}$, the minimum for existence, at infinite utility, becomes infinitely great, regardless of how large the finite quantity RR' is and, therefore, the corresponding area $RR'SV$, the utility expressed by this area would become a relatively negligible quantity, so that the ratio between infinite total utility of OR and that of OR' , tend to the value of the *unit*.

As Cohen Stuart determined, and R. Frisch reported, the differentiation between the principles of equal and proportional sacrifice disappear. In other words: the principle of the *ratio of areas* is transformed into that of the *difference of the areas*, because the integral of the second member of the relationship [III] becomes independent of its second extreme r for $\bar{r} \rightarrow 0$; that is to say, it tends to infinity.

We have, however, already seen that the principle of distribution of the tax, regardless of the size of income (r), is precisely that of the equal sacrifice expressed already in the ratio [II] $\int_{r-s}^r f(x)dx = c$.

Considering the tax-free minimum with regard to relative utility, the principle of proportional sacrifice would therefore fail.

And this is the principle that Cohen Stuart in particular, followed by many other authors (in Italy especially by L. Rossi) considered to be the ultimate ideal of justice in the distribution of taxes among physical people, considered for their overall income.

[It is to be observed that marginal utility of the first units of income tending to infinity is not a sufficient condition to balance the difference between the two principles of equal and proportional sacrifice. In fact, the surface (total utility) contained by the curve of marginal utility, the x and y axes and the extreme ordinate can have infinite value. This depends, clearly, on the type of function adopted.

For example, the following very simple function is one of the infinite functions having the property in question:

$$y = x^{-n}$$

where y is the marginal utility, x is the income and $n > 1$. For $n = 2$, total utility takes a finite value $2\sqrt{r}$ (as r is the income). In fact:

$$\lim_{\varepsilon \rightarrow 0} \int_{\varepsilon}^r x^{-2} dx = \lim_{\varepsilon \rightarrow 0} \left[-\frac{1}{x} \right]_{\varepsilon}^r = \lim_{\varepsilon \rightarrow 0} (2\sqrt{r} - 2\sqrt{\varepsilon}) = 2\sqrt{r}$$

Let's keep in mind, on the other hand, that the observation made by Cohen Stuart and Frisch is valid, in any case, when we take the hypothesis that the trend to infinity of marginal utility of income becomes apparent in correspondence of the units after the minimum necessary for existence. The utility curve would therefore be asymptotic to the parallel line of the ordinate and abscissa corresponding in fact to the minimum as it has been said before. In that case, then, the total utility of income, *including also the units indispensable for existence*, necessarily becomes of infinite value].

In the atomistic view, which does not admit the existence of typical or average individuals and which therefore excludes the possibility of tracing collective or single utility curves, criticisms of non-measurability and non-comparability of utilities is not levelled at the principle of proportional sacrifice, based on the equality of homogeneous relationships between the removed and available individual utilities. However, once this rational vision has been accepted, the sum to be paid to the State would become a *voluntary offering* of the single taxpayers charged with the utilitarian calculation that leads to the equality of the hedonistic relationships in question. This conclusion is sufficient to logically legitimise the transfer of the calculation from the individuals to the governing class, whose judgment can be explained with the mass hypothesis on which we insisted earlier.

What must be theoretically stated with regard to the two justice criteria considered here is that they both imply (equality and proportionality of sacrifice) that, with the exception of those who have a minimal income for life and no utility to spare to fund public needs with their means, *all the members of the community*, regardless of their means or income above a vital minimum, *must contribute in some way* (progressive, according to the most common hypothesis of decrease of marginal utility of income) to fund the cost of indivisible public services.

I) When faced with this conclusion, the vision of the collective minimum sacrifice, in terms of utility, of the author who has supported it mostly in a theoretical setting must be considered, that is to say, Edgeworth (in *Teoria pura della tassazione [Pure theory of taxation]*, Bibl. dell'Econ. [Economist Bibliography], series V). (Carver had also covered this in *The Ethical Basis of Distribution and its Application to Taxation*, 1895, in "The Annals of the Am. Ac. of Soc. Science", and later in the study: *The Minimum Sacrifice Theory of taxation*, in "Pol. Science Quarterly", 1904).

Unlike preceding principles, this does *not* imply that *all* taxpayers who have an income over the previously mentioned minimum must be taxed and contribute in some way. Indeed, entire classes of taxpayers (whose income is less than the level of residual income equivalent to higher incomes after imposition) are exempt from taxation.

II) Furthermore, “the principle implies” that, when the tax is collected, the *residue* of all taxed incomes, after the application of the tax, is constant, and that all incomes are *levelled* at the same value. (This consequence, as we will see, has been denied under some hypotheses dealing with the mode of variation of marginal utility).

III) This disregards the *mode* of decrease of the utility of monetary income as long as it decreases in any case to require the tax to be progressive (maintaining the assumption of a single curve of income marginal utility). According to our approximate hypothesis of concrete reality, the modes of variation of utility, for subjects that are considered to be typical, are imagined by a presumed legislator.

Edgeworth rightly reports the substance of the principle of collective minimum sacrifice to Bentham’s vision expressed by the condition that total disutility is a *minimum* (to which the proposition of the total net utility caused by maximum taxation is reduced).

If we use t to indicate the tax and x for the income, the levelling towards a minimum of subsistence (m) is given by the expression

$$t = 1 - \frac{m}{x} \quad \text{--- [IV]}$$

Edgeworth, however, in the geometrical representation presented in *Teoria pura dell'imposta [Pure theory of taxation]*, hypothesises tax and marginal utility of income so as to obtain the levelling of net incomes well above the minimum level for existence. This is important for what will be considered later.

This principle of distribution of the tax has been symbolically expressed with the relationship:

$$w(r - s) = c \quad \text{--- (constant)--- [V]}$$

according to which the marginal utility of income [$w(r)$], net of the tax (s) is constant; and by the relationship

$$r - s = c \quad \text{--- (constant)--- [VI]}$$

which expresses that the tax (s) will be determined so that the residue of all incomes (r) after the application of the tax is constant; in other words, incomes result in being levelled at a single level.

I will explain these characteristics with numerical and geometrical representations:

Let’s presume that three typical subjects hedonistically evaluate the units of income in terms of the utility connected to them:

Units of income	Subject A	Subject B	Subject C
1st	10	10	10
2nd	9	9	9
3rd	8	8	8
4th	7	7	
5th	6		
6th	5		
7th	4		

If we presume that the total cost of indivisible public services requires 5 units of private income, and we want to realise the assumption according to which the collection of such units should determine a *minimal sacrifice* for the community, of which the three subjects (*A*, *B*, *C*) form representative types, it is necessary to collect the 5 units by asking for 4 from subject *A*, 1 from subject *B*, and none from subject *C*.

Generally speaking a representation that explains the principle needs to take into account the trend *not* necessarily characterised by an equal decrease, as long as it does decrease, of the curve of marginal utility. In the representation that follows, the hypothesis of equality of the mode of decreasing utility is used to demonstrate the following levelling of incomes on the x-axis.

Repeating the same line of thought, if the State wanted to collect a certain sum, to continue to comply with the criterion of collective minimum sacrifice from the three typical subjects, the State would have to demand sums $s - s'$ and $z - z'$ from subjects *A* and *B* and nothing from subject *C* (as the sums indicated above meet the required needs). The areas $ss'tv'$ and $zz'nr'$ represent the smaller sums of utility sacrificed in relation to the collection of the monetary amounts indicated. The equality $ts' = nz' = u'm$ demonstrates the condition [V], $w(r - s) = c$, that is to say, the constancy of the marginal utility after the collection of the tax. In this representation the equality



Figura 10

$os' = oz' = om$ can be noted, in terms of income, after the collection of the tax on the basis of the already mentioned principle. And this proves the relationship [VI]

$$r - s = c.$$

In this way the indivisible cost of public services is distributed by collecting units of income having the least utility for the overall set of typical taxpayers taken into consideration. This however would lead to the levelling of *current* incomes (at the moment of the introduction of this system of distribution of the tax). This effect has been used as a criticism of Edgeworth's principle.

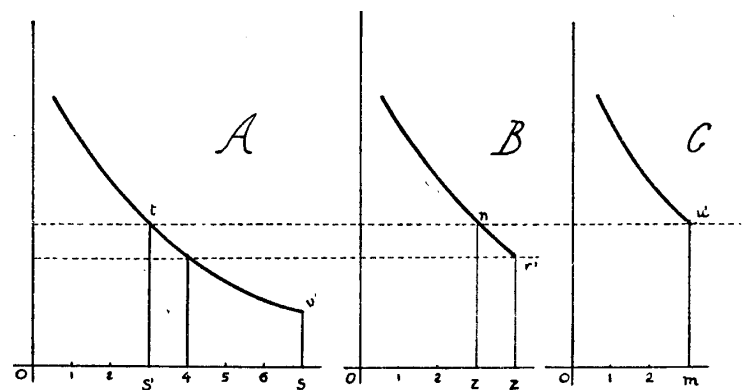
It is possible that this represents, in some countries and in some historical periods, the *ideal* of some political constitutions. However, in this case too, it would be necessary to take into consideration the future effects of such an evocation of higher incomes to the State, that is to say, of the effects on the production of new incomes and on the accumulation of new savings and assets.

However, to give due credit to the brilliance of the above mentioned economist, it is necessary to differentiate between reasoning in the context of pure theory and of practical applications. For this differentiation it is necessary to consider his thought in its entirety, even if summarily. Having adopted the principle of maximum satisfaction as the criterion of State action at least with regard to taxation, Edgeworth writes that, in the distribution of taxes, if the condition that the total net utility achieved by taxation is a maximum, then the condition of total disutility is a minimum. In this regard he quotes¹³⁸ Bentham for whom "every government is but a collection of sacrifices. The best government is the one in which the value of these sacrifices is reduced to the minimum".

¹³⁸ *Teoria pura dell'imposta [Pure theory of taxation]*, in Biblioteca dell'Economista, series V, Vol. XVI.

Edgeworth, however, sees the ultimate consequences of the *application* of the principle where he writes that: who is richer must be taxed for the benefit of the poorer up to the point where the complete equality of fortunes is achieved. He continues: “In this way it is possible to see briefly the acme of socialism, but it is immediately blurred by doubts and reservations”. And, adopting Sidgwick’s ideas, he sees “the enormous obstacles in the way that discourage practical common sense from moving towards the ideal of equality”.

“Such a strong progressive tax that leaves no motivation to the taxpayer to increase his wealth through savings would be an obstacle to social wealth even though it would improve distribution”. This would be a disadvantage offset on balance by the “probable” increase in savings among the poorer classes and the increase in productivity of workers. There would also be “abuses” and “evasions”. And also: 1) “These widespread but succinct reservations would reduce the mandate, revolutionary at a first consideration, of pure utilitarianism as it is normally understood”; 2) Mill states that “more than anyone, the utilitarianist wishes for provisions to reduce inequalities in wealth, with taxes on hereditary successions and increases in non-earned assets”; 3) After recalling that for Carver the minimum amount of sacrifice, with regard to the entire community, is ensured by collecting the entire tax from those few incomes that have the lowest final utility, Edgeworth suggests that the principle of minimum sacrifice is the absolute criterion for the tax; without doubt it must be limited *in practice*, so as to be applied to justify differential taxation, on the basis of other differences other than that of the magnitude of the income (differences in the continuity of income, civil status, number of children, age and other relevant circumstances); 4) He criticises the criterion of sacrifice equal to that of proportional sacrifice because: *a*) first of all (in the hypothesis that the decrease in marginal utility is more than proportional to the increase in income) it can lead to a collection of income so large as to leave the owner very little motivation in increasing his income beyond a certain limit; *b*) from a theoretical point of view, in the previously mentioned hypothesis of the decrease of marginal utility, the limit of application of the principle of equal sacrifice appears to be arbitrary; 5) He believes the principle of equal sacrifice to be implicit in that of the minimum collective sacrifice, this latter “tempered by the consideration of the development of wealth and other benefits”. To support his own statement, he quotes a passage from Mill, in which it is said that “whatever the sacrifices that a government requires of people and classes, it is necessary to be such so that, as far as possible, they affect all equally. This mode, it is observed, causes the minimum overall sacrifice”.

However, the hypothesis on the basis of which this has been considered is that of the *equal trend* of the *curve* of marginal utility of income for all taxpayers in the previous graphic demonstration.

If we hypothesise some *diversity in the curves of utility*, it might be useful to remember and extend Ricci’s fine demonstration, with graphical representation, of the thesis according to which *the effect of levelling of incomes is not derived* from the application of the criterion of taxation leading to the *minimum collective sacrifice* (“La Riforma Sociale” [Social Reform], No. 6, 1933).

This shrewd author, after assuming that individuals belong to homogeneous classes of beneficiaries of income, here limited for simplicity to two (the rich and the poor), considers two corresponding subjects with regard to the hypothesis that they are perfectly identical with regard to the most urgent needs, while they differ from each other with regard to other needs (and for the corresponding utilitarian appreciations).

From the premise of this hypothesis derives the fact that the curves of utility of the respective monetary incomes will be the same or *coincide* along the first arch, corresponding to the x points OA and OA' of the geometrical representation¹³⁹. In the second arch, the curve of the taxpayer R (rich) has a slower decrease compared to income OD' , greater than income OB of the (poor) taxpayer.

Presuming that the State needs to distribute a quantity of income equal to $B'D'$ between both typical taxpayers, if income P is equal or less than OB , then he will be *exempted* from the tax, which will be *collected entirely* from income R .

To help the student, I will assign numerical values to the geometrical segments. Let’s presume that P ’s income is 3,000 units (equal to OB), and that the income of taxpayer R is 8,000 units (equal to

¹³⁹ Here completed.

$O'D'$). The State collects a tax of 4,000 units. In this case it will seek this only from taxpayer R by collecting 4,000 units, corresponding to the abscissa $B'D'$, and will ask nothing of taxpayer P .



Figura 11.

From the figure it appears that, because of the effect of the imposition so distributed, the *final degrees of utility* of the two incomes are *equal* ($BZ = B'N$), but the corresponding *incomes* are not *levelled out*. In fact taxpayer R is left with 4,000 units ($= O'B'$) and taxpayer P with 3,000 units, even though OB is less than $O'B'$.

If we make the hypothesis that income P is less than OB (for example 2,500 units), there is *no levelling* of either *marginal utilities nor of incomes*, because, as it can be understood from the graph, CF is greater than $B'N$ and, as we have assumed, OC is less than $O'B'$.

Finally, if we hypothesise that income P is greater than OB and equal to OQ (for example 3,500 units), the tax will be distributed between the two typical taxpayers (for example to the extent of 3,700 units $= TD'$, charged to R which is left with 4,300 units $= O'T$; and 300 units charged to P who will see his income OQ of 3,500 units reduced to 3,200 units $= OK$). In this case there will be *equality* between their respective *marginal utilities* ($KM = TS$), but the two *incomes will not be levelled out*, as $O'T$ is greater than OK .

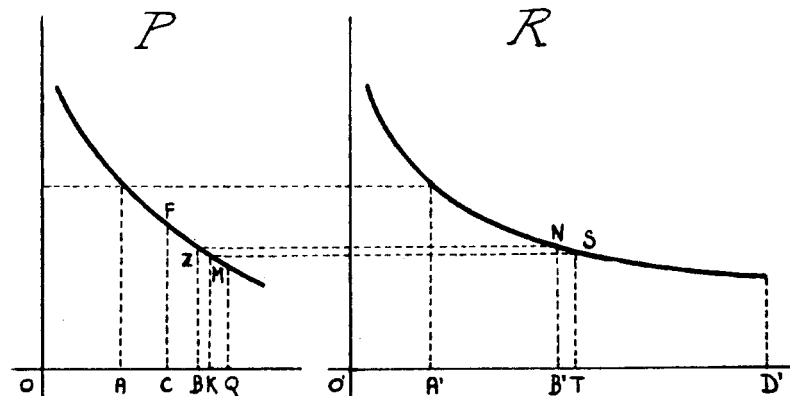
As can be seen, in the context of Ricci's hypotheses, there is no longer a base for the greatest objection, which is legitimate only in an empirical and not a theoretical setting, that is to say, that the economic and social effects that would derive from the integral and consequential application of the principle of minimum collective sacrifice no longer apply.

However, this demonstration, typically considered, where Ricci has made hypotheses that have some probability of corresponding to real events, still belongs to pure theory, which pursues the objectives of abstract knowledge that inspire these lessons.

F) Ragnar Frisch gives two examples, as "modifications that are necessarily applicable in the *practice* of the principle of levelling out", which he qualifies as:

a) *The principle of the marginal difference*, according to which the absolute *increase* experienced by the *marginal utility* of money, as a consequence of the collection of the tax, will be the *same* for all taxpayers; that is to say, it will be equal.

This principle is expressed in the relationship

$$w(r - s) = w(r) + c - (c = \text{constant}) - \text{ [VII]}$$

b) *The principle of the marginal relationship*, according to which the tax should be limited so that, in its application, the *marginal utility* of money is *increased* in the *same proportion* for all taxpayers.

This relationship should result

$$w(r - s) = (I + c)w(r) - \text{ [VIII]} .$$

For a perceptive illustration of these principles, we need to consider the graphical representation in figure 7.

For brevity, I will refer readers to the work of R. Frisch, quoted several times, for its analytical developments and for the expression of the *general marginal principle* (the expressed ones are cases of these, especially the principle of collective minimum sacrifice). I will limit myself to say that it takes into account the nature of the *relationship* that links the *values* of the *marginal utility of money, before and after the application of the tax*. This relationship has been expressed with a function: $w(r)$ indicates the marginal utility of money *before* the collection of the tax and $w(r-s)$ indicates its value after this, as a function of $w(r)$. Indicating this with $G(w)$, we have

$$w(r - s) = G[w(r)]. - - - [IX]$$

Each form of $G(w)$ is in relation to a definition of justice.

After discussing the various cases, Frisch asks himself if the formulations of “justice” adopted have any practical utility: he finds this in the possibility of formulating the problem of *interpolation*, applicable to the graduation of the rate of tax on the income. Let’s presume that, for political and social “considerations”, for a “common sense judgment” or for other reasons, it has been decided that the three incomes of 3,000, 5,000 and 1,000,000 are subject respectively to a tax rate of 1%, 7% and 50%. *If we presume marginal monetary utility to be known through statistical observations*, the author believes it is possible to determine the *intermediate* rates with minimal arbitrariness, or at least with a “much less damaging” level of arbitrariness than that which would be introduced by *directly* interpolating the function of the rate of the tax.

Einaudi, arguing with L. Rossi, thought that the construction of an entire progressive scale after having fixed the two extreme points of the scale according to politico-juridical directives was a *simple mathematical calculation*. (He recalls the formulae of continuous progressivity, adopted in Italian personal taxes). It is known that *infinite curves* pass through two fixed points and so the problem is therefore indeterminate. R. Frisch, rather than directly interpolating the function of the rate, believes it opportune to use the *knowledge of the curve of utility of money* in the statistical procedure (discussed until now by academics). In this case also the degree of arbitrariness is apparent, limited however to a sector illustrated by rational premises, only in a *certain way* statistically confirmed.

After what precedes, I do not share Fasiani’s opinion (or that of those who think along similar lines) when he (at page 9 of the *op. cit.* Vol. I) states, as I suggested in paragraph V of this chapter, not only that there is no scientific principle for the progressive tax, but also that the attempts to “explain”, in pure theory, the dominant feelings of justice are nothing but “logical distortions” when we presume a hypothetical definition of it. On the other hand, I see with pleasure that there is an affinity in approach between Fasiani and what I have already stated in previous editions of these lessons, here reproduced with regard to this point. That is to say, the illustrious academic confirms this and more widely demonstrates it, overcoming his previous apriorism, that it is not “absolutely impossible to reach some induction with regard to the structure of the curve of utility” (p. 68 and subsequent ones of Volume II of the *op. cit.*).

VII.

CONSIDERATIONS OF FINANCIAL POLICY AND STATISTICS INFLUENCING THE QUANTITATIVE DETERMINATION AND THE INTRODUCTION OF PROGRESSIVE TAX. PROGRESSIVE SYSTEMS.

In conformity with the orientation of this course of lessons, which intends to use logical economy, as pure theory, for the setting of problems of financial economy, there is no scope in this for the study of the *political* aspect of the problem left to those who believe in political science. In the previous pages I have not claimed the attempt to give uniformity, such as those demonstrated to have universal value but limited spacial-temporal application, to this science. Here we limit ourselves to

remembering that the political aspect, considered in juxtaposition with the economic and other aspects, is certainly *in practice* one of the important *components* of the determination of the resulting, *concrete* progressive graduation of taxes, in the *positive* legislation of the various States. The political component helps the reaching of diverse solutions to the *concrete* problem, as a function not only of the utilitarian variable, that is to say, of the judgment that, on average, governing classes formulate about the variation of sacrifices of enjoyment of utility, with the increase of tax rates in relation to increasing incomes, but also of other factors of objective, statistical, etc., economic character, that *I will limit myself to recognising here*.

A) The French Revolution had led to the vision of the ideal system of distribution of the tributary burden in *proportionality*, as a typical case of equality. Social currents, in the conflict between rich and poor, have led to the fiscal burden being charged to wealthier rather than poorer subjects, with strong exemptions of minimal incomes and progressive taxes.

Wealthier people have tried to resist the adoption of proportional tax rates, which coexist with progressive measures in tributary systems.

B) The political economy concern of avoiding discouraging the *production* of income and the *accumulation* of wealth has limited progressivity, leading to progressive taxes rates becoming proportional after a certain point.

C) Finally, the different *degree of concentration* or of convergence of incomes and of wealth in the various countries has led to the adoption of rates with different levels of progressivity¹⁴⁰; in this aspect, generally speaking, progressive taxes apply to a higher taxable income in those cases in which the average income is higher and incomes and assets are more concentrated. Let's think of Pareto's representation (fig. 12): in this, incomes are represented on the *x*-axis and the corresponding number of beneficiaries of income on the *y*-axis.



Figura 12.

In this way, the sections of surface included by the curve give the number of individuals with an income between X and $X + K$.

¹⁴⁰ I will refer the reader to another edition of this course for the analysis of the *objective* principle through which the disequality in the distribution of incomes must not be increased or decreased by the imposition. This, according to some, *therefore*, should be proportional, and according to some others, progressive. The issue is still the subject of scientific discussion, which can lead to a different formulation of the principle, in the sense that the progressive imposition does not change the type of distribution of incomes.

If two different curves (tsn and $t's'n'$) expressing two different income distributions are taken into consideration, the repercussion of this on the revenues derived from taxation with a similar trend of progressive rates is clear. Generally speaking this will have *ceteris paribus* a lower tax revenue when the distribution of income leads to few very high incomes and very numerous modest incomes. The case is approximately represented by the curve tsn and is very different from that expressed by curve $t's'n'$, if not its reverse from the fiscal or State (tax revenue) point of view.

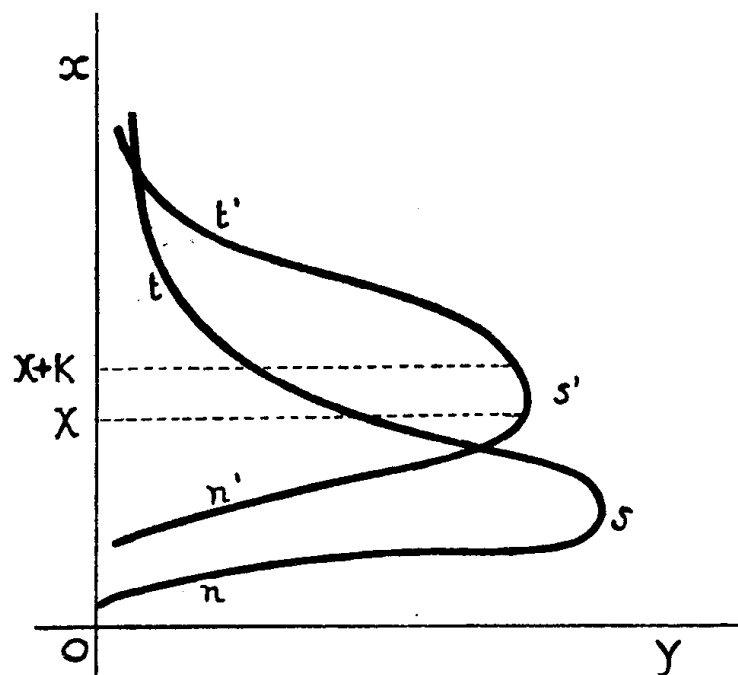
D) All the economical, social and political considerations in this paragraph have an influence on the determination of the *concrete* scale of progressivity of the tax rate. It is understood that the preceding thinking regarding progressivity refers to the real case of the *personal* progressive tax.

Furthermore, as has been mentioned in the classification of tributary revenues, for now it is possible to consider the decrease of the marginal utility of income (or of wealth), as we consider *all* the income available to individual physical people for the satisfaction of needs. That is to say, it is not possible to imagine the case of real taxes as progressive tributes.

The preceding thinking should take into account the relationship between the overall debt of the tax and the overall sum of the income available to the taxpayer. However, by and large, it is possible to apply the preceding premises to real cases of general global taxes (such as the extraordinary Italian taxes of 1919 and 1947 on overall assets or the income supplementary tax, integrated with that for unmarried people for the progressive rate correlated to the income variable).

The progressive rate cannot be applied to real taxes for the following reasons: 1) by definition, real taxes, when they do not present personality characteristics (which we will discuss with regard to differentiation of taxable incomes), normally consider quotes of income as homogeneous to each other, and this is admissible because such tributes consider income (or assets) *in themselves*, independently of the conditions and the hedonistic evaluations of the subject receiving the income (or owning specific forms of assets); 2) from a rational point of view, which is more apparent when the issues put forward in this chapter are taken into account, it is not possible to apply hedonistic appreciations relative to the utility of income and the political and social premises of progressivity to the utility of income and the political and social premises of the progressivity in the case of individual incomes, that is to say, deriving from single (estate and moveable) sources. In fact, it is not known if the 100,000 units income, deriving from land, represents a single voice of entry for a taxpayer or one of the components of a total of 1,000,000 units, whose remaining 900,000 units are made up by rents from buildings or industrial or professional revenues. It is not possible to verify this for the same reason that *real* taxes (on incomes, for example, from land) are independent from the economic (overall income) condition of the physical person or the taxpayer.

This does not mean that in practice it is not possible to find real taxes with progressive rates. For example, during the 1915–1918 war, Italian real taxes became progressive (on incomes from land, buildings and moveable wealth) but this was due to exceptional circumstances, due to the State needing to source extraordinary revenues, regardless of the respect for rational principles. Such rates were returned to be proportional with the Royal Legislative Decree of 10 October 1924. Later there was the case of the progressive tax on share dividends (established with Royal Legislative Decree no. 1744 of 5 October 1936), which is real because it is charged to the income from *a single source* (shares) and it disregards the personal situation of the taxpayers (partners). However, progressivity is admissible in this case, as a means of achieving *extra-fiscal* objectives, which consist of protecting the future prospects of commercial companies by reinforcing the conditions of their assets, and at the same time by preventing high dividends attracting capital and savings to investment in shares rather than the purchase of State titles, given the historical circumstances. Similarly, progressivity of the tax on war profits, obtained from *some* sources of income, is justified in the light of concepts that are *in part fiscal* (relative or special or of differential contributive capacity), *in part social and political*, in legislation in Italy and abroad, as we will see when dealing with the main objectives for the distribution of taxes.

E) Having made these premises, we now consider through which procedures the progressivity of the rate of the imposition has been realised.

First of all, a *system of progression by class* was applied. For this method, incomes are divided into classes, and a percentage rate of tax, which increases progressively, is applied to *each*

subsequent *class* in a growing order. For example, incomes between 5,001 and 10,000 units attract an 8% rate; those comprised between 10,001 and 15,000 units, 10%; those between 15,001 and 20,000 units, 11%, and so on. In symbols, with $(x_1, x_2), (x_3, x_4) \dots (x_n, \infty)$ as n classes of income, the corresponding rates t_1, t_2, \dots, t_n remain constant in the interval. In a geometrical sense, according to a graphical representation of immediate intuition, in which the classes of incomes are drawn on the x-axis with the corresponding rates on the y-axis, the y ordinate maintains a constant value when we pass from x_1 to x_2 . And the function of progressivity takes on the trend of a broken line, shaped like a *ladder*, growing for classes of x , with steps parallel to the x-axis.

The problem that until now has been unanimously declared by academics and the most conspicuous of this real type of progression is given by the fact that, in the *immediate passage from one class to another*, sudden increases of tributary burden occurs so that it can happen that a taxpayer with an income close to the lower limit of a class *is left*, after the collection of the tax, *with a net income which is lower than that of taxpayers at the top* of the immediately lower class. If, for example, the 9,001 to 10,000 units income class is taxed at a rate of 10% and the 10,001 – 11,000 units class is taxed at 11%, a taxpayer with an income of 10,100 units will pay 111 units of tax, and will be left with 8,989 units, while a taxpayer with a 10,000 units income will pay 1,000 units of tax, and will have 9,000 units left to his disposal. The difference becomes more significant when passing to higher income class or with increases in the rate of the tax.

This problem (until now, and also recently, universally condemned by mathematicians such as Folliet and D'Addario, to whom I will shortly make reference) was first solved according to a first logico-technical approximation, applying the *income bracket progressive tax*. That is to say, consecutive brackets of taxable income were identified and for each one a corresponding tax rate was established, so that the same taxpayer would pay the income taxes corresponding to the consecutive brackets of which his income was made up. For example, in our case, the taxpayer with an income of 10,000 units would pay 10% of 10,000, i.e. a tax of 1,000 units, plus 11% of 100 units: 1,011 units in total, with a residual income of 9,089 units.

Symbolically, let's say that the consecutive taxable income brackets are quantitatively as indicated for the progressive tax per class:

$$(x_1, x_2), (x_2, x_3) \dots (x_n, \infty).$$

The difference in the measurement of the rates in the “bracket” system consists in the fact that corresponding $t_1, t_2, t_3, \dots, t_n$ are not applied to the *entire* income, and increasing with each higher class, but respectively to the *differences* between the amounts that make up the increasing brackets. That is to say that the tax varies according to the expression:

$$i(x) = (x_2 - x_1) t_1 + (x_3 - x_2) t_2 + \dots + (x_n - x_{n-1}) t_{n-1} + (X - x_n) t_n$$

Even this system, however, is not perfectly rational because it does not take into account, within the limits of the same income bracket, the presumed continuous decrease of the utility of income and therefore the different contributive capacities.

Rather than try to *correct* – in the restricted meaning specified here – the irrational points presumed by these two modes of distribution of the income curve, there has been a switch to *continuous* progressivity. I have expressed this for the tributary constraint of this type, according to the symbolic expression indicated in the *Introduction*, with $y = ar^r$ and better with $y = ar^h$ where y is the tax rate, r is the income and a and h are two “constant” parameters. This represents the ascending curve, with increasing income and decrease of its utility in the vision of the legislator. With this formula the tax rate can be calculated and applied through tables that allow rounding up, in connection with the law. So dramatic jumps in the passage from one bracket of income to another are avoided and a tax rate that varies minimally with consecutive, infinitesimal increases in income, is obtained in perfect correspondence with the objectives of the legislator.

For the supplementary income tax, according to the scale of tax rates in 1923, tax rates resulting from the interpolation of the following function were applied in Italy:

$$y = 0.04186 x^{0.39637}$$

where y , the dependent variable, represents the tax, and x , the independent variable, represents the taxable income, while the two decimal numbers are the two (constant) parameters.

The prevalent circumstance that determines the choice of *points* (minimum and maximum rates) between which progressivity varies is given by the dominant *political* trend of governments and parliaments and of other already mentioned *economic, psychological, etc.*, circumstances. The progressive tax, fuelled by excesses, has been in many cases a powerful party political instrument, used by one class for the damage of another.

In conclusion to this paragraph, I will repeat that the measure of the tax rate is not regulated on the basis of *a single* assumption, but results from the coming together of economic, political, juridical, psychological, etc., elements. It is therefore difficult or very rare that the problem of the determination of the “optimum” progressivity of taxes can be solved on the basis of a purely economic and abstract treatise (*analysis*). This is because, in *practice*, the solution is influenced by the action of the previously mentioned factors that *synthetically* have put forward different historical solutions. In this sense, at the start of this course, it was specified that cooperation between scientifically distinct disciplines that study the financial phenomenon was necessary for the purpose of finding a solution to given tributary problems.

Here we have insisted on the contribution of pure economic theory to the explanation of an aspect of this complex problem.

VIII.

CRITICISM OF THE “FUNDAMENTAL” PROPERTY OF PROGRESSION AND ITS RELATIVITY

Several modes of variation of the progression of the tax are theoretically conceivable. This tax is represented by curves having different progressivity at each *point* and diverse *global* progressivity. These are concepts that some authors, the quoted Folliet and D’Addario among them, have considered with contributions that synthesise the measurement criteria and the representation of the two types of progressivity (see in particular D’Addario’s interesting article on the *Giornale degli Economisti [Economist Journal]*, November – December 1950, which we will consider in another edition of these lessons). In the meantime it is important to consider the difference between: *a) the degree of progressivity* that expresses the *variation* of the tax rate with the variation of taxable incomes; and *b) the burden* of a progressive tax, which regards the magnitude of the tax rates.

However, the “general” properties that appear to many authors as rational conditions of progressivity and even intrinsic to this type of imposition, according to D’Addario’s critical synthetic presentation (in the “Archivio Finanziario” [Financial Archives], 1950, Padua, Cedam, and in the quoted journal, “Economia Internazionale” [International Economy], May 1952), are as follows:

- a) the rate $[t(x)]$ must have positive values;*
- b) it must be continuous;*
- c) it must be increasing and must converge, for x (taxable income) tending to infinite, at positive value $k \leq I$, assumed as the rate’s upper limit;*
- d) it must increase so that a higher taxable income must correspond to a residual income not lower than that corresponding to a lower taxable income.*

I will not pause on the two first intuitive properties of the rate of a progressive tax.

However, the properties expressed in *c)* and *d)* deserve a comment.

A) Point c) indicates that the tax must not absorb the entire taxable income.

This specification is interesting because, in treatises and in some specific texts (famous also for this affirmation, which was taken as granted, necessarily in broad lines, is the text by Martello),

the aphorism or paradox can be found, according to points of view, that: “the progressive tax consumes itself”, because it makes the taxable object disappear.

This vision may be compatible with a very specific case, among the many numerous modes of variation of the curve of progression, represented by the trend of the function whose ordinates increase with income (represented on the x-axis) up to 100%, that is to say up to final absorption.

[It is not stated that history ignores such cases: recently there have been cases where there was a desire to proceed with a revolution of the social system in the collectivistic sense, inducing rioters to adhere to this with the apparent legalitarian form of the “persuasive” progressive tax, evoking assets as well as incomes. Other cases of fiscal policy can be found in extra-fiscal progressive taxation of excess profits due to circumstances created by history and by State action, without merit for individuals, and when “justice” or the “morality” of the time leads to the belief that the enrichment of individuals or groups belonging to a given community is inappropriate and inadmissible].

Generally speaking, the condition *c*) is to be interpreted in the sense that, normally, tax rates are different from what is the “pure” progressive tax, with a constantly increasing trend, but confer to the tax characteristics of a *degressive* tax. For this the tax increases from a minimum, corresponding to a quantity of non-taxable income (*m*) (exempt minimum) up to a maximum income (*M*), from which point the rate remains *constant* and therefore the tax becomes proportional.

(We have seen this to be a limitation that normalises the extreme deductions of the principle of minimum collective sacrifice, according to Edgeworth’s warning and geometrical representation).

In other words, *practical* reasons suggest the elimination of the case limit of the evoking tax, which *theoretically* derives from a type of imaginable abstract progression.

This is said to be a property that responds to an empirical need and is not necessarily linked to the rational vision of the problem. From this derives the probable choice of the term “pure” for the progression that can reach the point of absorbing the taxable income until 100%.

B) Furthermore, I want to demonstrate first of all the opinion that has been presented as the one suitable to characterising a property of the progressive tax (*d*), also an empirical one and which, at least theoretically, corresponds to an hypothesis that reflects a particular psychology. This psychology, however, is not that of the entrepreneur to whom it is referred in the words that appear to interpret “the common sense and human nature” such as it has been formulated by D’Addario and described by Einaudi in typical pictorial style.

With these arguments, *in any case*, it does not become a *defect* or an *inconvenience* for the tax by class corrected by the system of income bracket measurement, or even better, with the system of continuous progression: a correction that is based on the criterion that is taken as a *general property* where it can meet the needs of a *special* hypothesis.

I refer to the studies of second approximation that have been carried out by modern economists and which figure happily in the most up-to-date treatises of international literature and that I have recalled in part in a relatively recent essay in which I criticised some of the effects of the opposite assumption, of those who have excluded other expansions of meaning to be assigned to the psychology of producers of wealth and have criticised the classic hypothesis of the coincidence of maximum achievement of income with the maximum satisfaction of entrepreneurs. This is a coincidence that is the only hypothesis that justifies property (*d*) of the progressive tax, in my view.

(See E. D’ALBERGO, *Effetti delle imposte e teorie del full employment [Effects of taxes and theories of full employment]*, in the journal “Economia Internazionale” [International Economy], August 1948). D’Addario introduces the psychological variable in the calculations of objective quantities. In one of the quoted works (see *Archivio Finanz. [Financial Archives]*) he suggests that property (*d*) is “essential”. “Human nature and common sense justify its importance”.

“Ordinary flattening taxes, that is to say, that flatten out incomes or assets, ordinary or extraordinary depressing taxes, that reduce incomes or assets to decreasing values as their total value increases, not only are no longer deemed to be acceptable by even the most reputable theoreticians of the principle of minimum sacrifice (Edgeworth), but in particular are damaging to human nature and common sense”. “It is not possible to pretend that men forget their nature and cease to wish they could live and operate to achieve the objectives they have a propensity to achieve; and for this reason it is necessary for the tax to be collected taking into account that men do not work, do not produce, do

not save, do not take risks without the expectation of an income sufficient to justify their efforts in working, saving and do business". Property (*d*) synthesises therefore the need that the tax does not nullify or stifle the interest of the taxpayer in the production of a higher income or the accumulation of greater assets, as the main effect of the application of flattening or depressing taxes would be to terrorise owners and savers, to quash their interest in industry and therefore to lead to an increase in misery and unemployment (EINAUDI, *ibid*, according to D'Addario).

Even though I reserve the opportunity to examine, in another context, the relationship between the psychological variable and the concrete mode or objectives of distribution of tax rates, according to property *d*), for now I observe that this *is not essential* in the sense of being typically universal and absolute of what in a very literal and accepted meaning "serves as a principle, of primary reason, of support to human behaviour". It is however a property that responds to a partial vision, *relative* to a type of hypothetical psychology of the producer of incomes, and therefore presumes the uniformity of human nature (in other words psychology) interpreted by the common sense of the observer or of the legislator, of whom it would explain the logical premise that most likely directs the distribution of tax rates of the progressive tax, according to the above mentioned property.

Indeed, it is sufficient to think of another psychology that explains the behaviour of subjects or men who work, produce and save and take risks, to obtain an income sufficient to legitimise the effort of working and doing business, different from that postulated by Einaudi's words, which D'Addario makes his own. In fact, if the trend to obtain the maximum (compatible with the type of fiscal constraint) income or profit, according to the classic vision, is taken into consideration, it is presumed that the behaviour of the producer of income complies with the mental attitude of those for whom the maximum *income coincides* with the *maximum satisfaction* deriving from work, especially that of the entrepreneur, which is explicitly kept in mind when considering the explanation of the uniform need of distribution of the tax according to the progression that avoids the defect of the one "for classes".

I refer the reader to my previously quoted essay with regard to all converging opinions in this sense that are presented and they are now to be found in treatises of economic analysis published in particular in English in the last few years, and to which I will return for the analysis of the economic effects of taxes. I note, in a second approximation by contemporary economists, who have in mind hypotheses suggested by case histories in which the mental attitude of entrepreneurs is highly representative and strongly analysed (United States), the *divergence* between maximum satisfaction and maximum income produced and obtained by the protagonists of economic life, because it states:

I) What is expressed in terms of "*supply of enterprise*" is a *subjective and variable* quantity, whose *difficulty of measurement* is recognised but which does not deny the existence, represented with indifference curves, of point (or points, generally speaking) where the curve is tangential to the utility.

II) In consequence, the assumption of the classical or traditional theory according to which the entrepreneur's tendency to realise the maximum profit, viewed as a rational behaviour, rises to the role of clearly Cartesian axiom and such as not to require verification or justification, makes theoretical analysis easier but responds to a particular psychological mental attitude as an existing special hypothesis, but this hypothesis does not explain all facts, many of which are based on "*non-pecuniary motives*" that dominate – spontaneously or as a social *constraint* – the behaviour of entrepreneurs.

III) The case of coincidence of maximum profit and satisfaction derived from work would be present in the hypothesis in which the indifference curve is parallel to the x-axis, a hardly plausible or a special case (in the diagram relative to the case of monopoly that figures in my essay, to which I refer here, production is represented on the y-axis and income in monetary terms on the y-axis).

IV) Very distant from this (III) assumption is that of the typical subject as entrepreneur, extremely ambitious to operate as the "captain" of a large industry, lover of prestige and power, who prefers to promote the *expansion* of his own business at the cost of minor profits, that is to say, compared to those which would otherwise be achieved (without the unemployment and misery Einaudi speaks of: on the contrary, where an increase in employment derives from the hypothesis).

The subject as it has been configured above:

a) in conditions of monopoly will renounce maximum utility and will aim for a level of production to the right of that identified on the x-axis by the ordinate of the maximum net utility, in the traditional representation of Cournot. In fact, in figure 13, the tangency point r of the indifference curve β (which represents the existence of a sensible *supply of enterprise*) with the net utility curve (derived, as it is known, from positive and negative differences – respectively profits and losses – between overall revenue and overall costs: in other words, between the ordinates of the line OM' and of the curve $OH'P'K'$) on the x-axis identifies production (effort) OR greater than that of OP . This is so in spite of the net utility PM , corresponding to the latter, being the maximum, in monetary terms – and therefore greater than Rr – compatible with the trend of the previously mentioned overall revenues and costs.



Figura 13.

[The indifference curves y are configured with a trend appropriate to indicate a limited *supply of enterprise*, typical of the so-called “lazy” entrepreneur, who finds the maximum satisfaction in correspondence of minor monetary utilities (ZZ' in the example) of the maximum PM obtainable, but accompanied by a lesser (production) creative effort ($OZ < OP$). The indifference line α , parallel to the x-axis, graphically translates case (III), in which the coincidence of the maximum satisfaction with the maximum monetary gain can be found: this is, as we have said, the implicit hypothesis by Cournot. As I have said before, I will return to this subject at length in another chapter, when I will address the study of the economic effects of the imposition].

b) in conditions of imperfect competition leading to increasing revenue, will push production towards a limit compatible with the minimum satisfaction obtainable in the profession of entrepreneur.

That is to say, presuming income to be divided into two quantities, in the spirit of Marshall: 1) salary for the direction or management of the enterprise and 2) profit as residual income with nature of return, the minimum income needed for the entrepreneur not to abandon his function and become involved in something else, is that which leads to the maximum *satisfaction*, correlated to the *salary* for the management of the enterprise, not with differential profits.

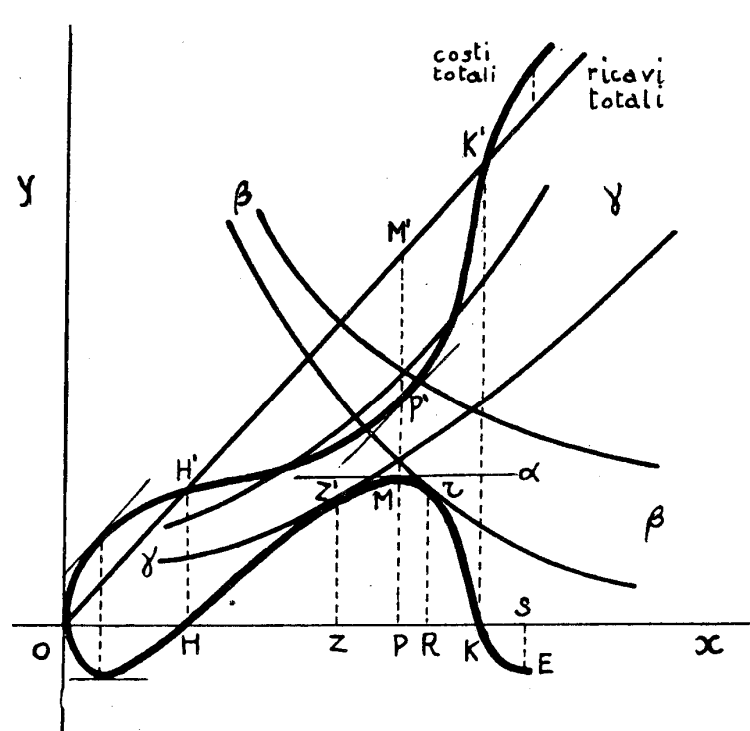
[Moving the thinking to the traditional graphical representation (Fig. 14) of the equilibrium conditions of the dominant enterprise in imperfect competition (here simplified in a case of partial

monopoly), there is the entrepreneur who, rather than stopping at production OG , where the marginal cost and marginal return



Figura 14.

of the enterprise are equal (meeting the curves mm' and ER in T) and where its monetary earnings ($PZSQ$) are at their maximum, finds greater satisfaction, in the terms indicated, by increasing efforts and leading for example to OG' (where the marginal cost is equal to the partial demand ED for the enterprise), in spite of the fact that the return is reduced to $ABT'D$; if not even to production correlated to the equality of the average cost (curve uu') and of the price, in which there is an absence of differential earnings, and the entrepreneur behaves *as if* he operates in conditions of perfect competition, that has exhausted its effects].

c) In conditions of free, non-ideal (Fig. 15) perfect competition he will tend systematically to increase production OP , whose marginal cost is equal to price PP' and where the maximum income is $HFP'S$, with

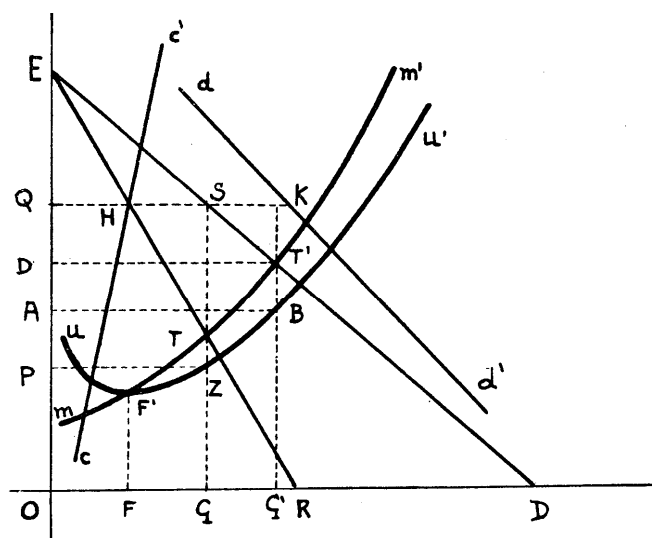

Figura 15.

the nature of income (AMOROSO: *Economia di mercato [Market economy]*, *op. cit.*, XXVII) and push up to OR a level of production which, realising the equality of average cost and price in R' , does not allow any differential income.

V) The assumption of the coincidence of the two maximums – objective or monetary and subjective or psychological – which could be traced back to the puritanical mentality of success which

considered “making money” an end in itself – responds to hypotheses appropriate to explaining the first phase of the capitalist world and which can be admitted as a first approximation.

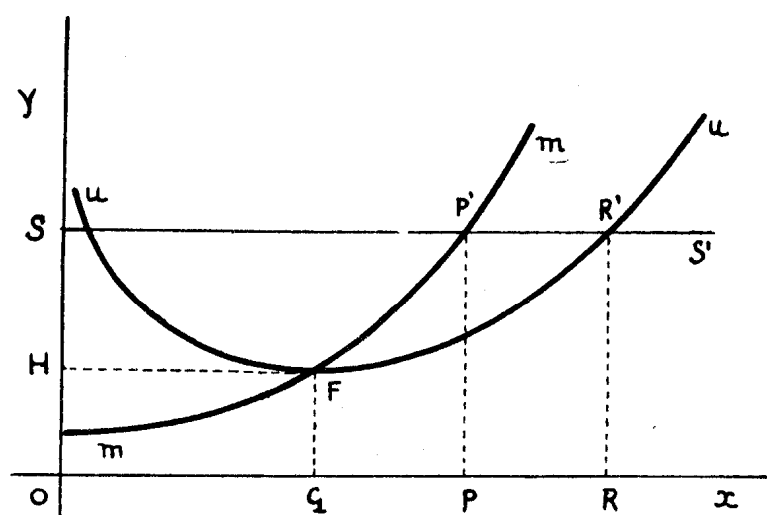
The type of men who consider work as a pleasant labour, who derive satisfaction from work – other than that achieved from the income they receive for it – dominated by ambition, by the desire of emulation and rivalry, by pride and similar impulses, when they organise their activity, is believed to be *typical* of the entrepreneur in our times.

VI) The assumption that the entrepreneur maximises profits as a rule of behaviour is based on partial observations and implies a *special hypothesis* regarding the psychology of the entrepreneur. It represents an empirical law that is not necessarily applicable to each entrepreneur and that can be considered not true in relation to a typical entrepreneur.

Let's make reference to property (*d*), based precisely on the “human nature” whose trends and inclinations with regard to attitudes towards wealth or income flow have been examined in a second approximation. It will be noted how, in the context of a progressive tax, other illustrious authors have considered *only one* trend for their utility in relation to cost or effort or productive enthusiasm, extending this to *all subjects* who are considered as being in receipt of an income reduced by the progressive tax.

This tells us that the function $\lambda(x)$ in the following expression:

$$\lambda(x) = x [1 - \tau(x)]$$

that expresses the residual income corresponding to taxable income x (after the collection of the tax) and that D'Addario pragmatically considers must be “generally” increasing, may not be so or must not necessarily be so, without this necessarily leading to irrational settings or to those effects feared by Einaudi and other interpreters of the psychological world that may characterise a certain type of case history.

There would have been no need to insist on this “essential” characteristic or property (*d*) if a logical thread did not link my entire presentation to students regarding the graduation of rates of the tax. Indeed, even in those studies in which statisticians (such as Fisher and Ragnar Frisch, Folliet, D'Addario and others) coherently support the shifting of economic premises into quantitative (and, according to Folliet, philosophical) terms¹⁴¹ of the progressive tax, we find the *psychological and subjective variable*, arbitrarily shaped into a general or normal vision of a field in which personal taste, inclination and very variable individual hedonism are dominant. This may lead to the belief that property (*d*) is neither essential nor necessary as a characteristic of the progressive imposition, in mathematical expressed real systems.

In other words, property (*d*) has a validity that is limited by the hedonistic hypothesis linked to “human nature” and “common sense”. Property (*d*) is not *general* if the psychological assumptions it implies is not. On the other hand, as we have seen, reputable and current economic literature considers the coincidence of the maximum monetary profit and satisfaction as a *special hypothesis* or a first approximation in the constructions of pure theory.

I also want to recall Samuelson (*Economics, op. cit.*, pp. 173–174) who, with regard to the *net effect* of the progressive imposition – that is to say, when considering the concern that it may discourage productive effort and risk taking – states that it cannot be considered as *dogmatic*. In other words, there are hypotheses that do not require property (*d*) to be necessary or rational.

C) Furthermore, all this legitimises the belief – *mutatis mutandis* and by analogy – that the criticisms based on *no bridge*, inflamed by individualists and exclusivists like Robbins, are nothing but an interpretation of *one* hypothesis regarding collective hedonism. That is to say, individuals may *absolutely* be very different in terms of pleasures, inclinations and utilitarian evaluations.

This could also be seen as a *special hypothesis*, in other words, linked to a set of facts and to given territory, where that hypothesis is realistic. In the meantime, it may appear to be a *general* or normal hypothesis that presumably directs financial laws, in other words, when the legislator assumes

¹⁴¹ P. FOLLIET – Les tarifs d'impôts (Essai de mathématique fiscales) [Tax rates (Essay of fiscal mathematics)], Payot, Lausanne, p. 56 onwards.

a *uniform* decrease of utility as a function of income (as the main variable influencing utilitarian evaluations).

[Indeed a unique mode of thinking, a psychological second nature, has been admitted as a hypothesis (or as an axiom) by Einaudi, D'Addario and others in the logic of the graduation of progressive tax rates.]

I can't deny that some might demonstrate that the hypothetical vision I oppose here, which contributes to explaining the financial event, is special in terms of supplying a premise to correct the problem of the progressive tax by class. Like its rival vision, however, it is true that it explains a certain number of facts.

The important issue is that it is recognised that we are dealing with *relative* issues and that old theoretical positions need to be reviewed or denied the *absolutism*, in terms of criticism, in particular of the premises or hypotheses that explain progressivity as a mode to resolve the problem of distribution of taxes between rich and poor, whose "nature and common sense" [to use expressions which would legitimise property *d*)] help us understand the diversity of sacrifice, according to a common normal or general decrease of the utility of marginal income as this increases.

The assumption or hypothesis of a common or uniform or equal *mode* of reaction for subjects, when faced with a progressive tax that reduces income in the hands of those who set convenience calculations of production or the achievement of the same, should induce me to oppose their criticism of *no bridge*, like a *boomerang*. This is a presumption that Einaudi and D'Addario and other academics who think in this way base on *intuitions* drawn from the observation of "human nature" and the practical reverberations of "common sense" in individual hedonistic choices.

Indeed it is a *mass* problem. What precedes might authorise me to say to these illustrious academics that there is *no bridge* from emotions, from physical reactions, from utilitarian judgments of a subject to those of another, in judging hedonistic evaluations that the component parts of a mass formulate in imagining the convenience to proceed to the act of production of wealth, of income, in a manner compatible with progressive tax.

It is true that in the rational genetic explanation of the progressive tax (*A*), within the limitations of the hedonistic-economic aspect, we keep in mind the *fact* represented by the subjective attitude of the members of the community (in the judgment of the governing class, as I have discussed in this chapter), considering the *moment* in which *it is available* to them to meet their needs, when we hypothesise a *uniform mode* of decrease of the utility of marginal wealth or income, and that in the case (*B*) of the rational distribution of the tax (that is presumed to have been already explained or whose economic explanation has been disregarded, precisely because of the *no bridge* context), those who study the concrete way of distributing the tax presume or postulate or hypothesise a *uniform mode* to react psychologically for different subjects, at the *time* of the *achievement* of the income, unfavourable to the "defect" of the progressive tax that violates the above mentioned "essential property" (*d*).

In cases *A* and *B*, however, it is a matter of comparing utilitarian or hedonistic evaluations of different subjects, of evaluating hedonistic and subjective reactions of different subjects, when faced with the reality of the progressive tax.

In the two cases, *A* and *B*, it is a matter of discussing whether it is possible to rationally start (as we have done in these lessons) from *intuitions* based on observation (even introspective ones) of human nature, or on common sense, extending to the entire community (mass problem) the assumption or hypothesis of a uniform or common utilitarian mode of thinking and reacting of individuals, with regard to the fact represented by the tax that modifies quantities of wealth or income, to which individuals assign utility for the subjective needs or desires to be satisfied.

In brief, in cases *A* and *B* it is necessary rationally to solve the mass problems that the fiscal legislator needs to tackle and that require a judgment of psychological nature that encompasses the hedonistic modes of argumentation of the different components of the mass, and the uniform mode of reacting psychologically that is admitted for the formulation of property *d*) articulated by D'Addario.

However, coherence with the wide and most universal vision I have attempted to conceive in the presentation of elements of this science prevents me from pointing the finger at the inhibiting sign of *no bridge*, as I should rationally do on the basis of what precedes with regard to the psychology of

producers of wealth which is diametrically opposed to that hypothesised by D'Addario, Einaudi and others, in dealing with the imposition of the progressive tax. That is to say, I should recall the attention of the illustrious academics to their violation of the axiom of non-comparability of emotions, feelings, hedonistic evaluations or of ophelimities of the diverse members making up the community that they consider as a mass, applying to all the *same* utilitarian mask of protagonists in the production of wealth.

However, the *no bridge* position is not an axiom, after what we have abundantly expressed in our premises in this chapter, in particular in reference to the solution of the mass problem of the homogeneous judgment of the current governing class. Einaudi, D'Addario and the other academics who admit uniform hedonistic bases, derived from a singular vision of human nature, are not guilty of any violation in sharing the content of property *d*) of the progressive tax. I do however admit this to be their *hypothesis*, of which I have demonstrated the *speciality*, and I am the first to admit the legitimacy of this in the sense in which it has been formulated or justified by the above mentioned authors.

As long as they, however, also admit that my hypothesis of the uniform decrease of the utility of income with its continuous increase, presumed in the judgment of the governing class resolving the mass problem of the progressive tax, informing their decisions *also* with regard to the hedonistic variable – the one on the basis of which I have argued in this chapter – is also legitimate.

If there is an attempt to deny the genetic explanation of the progressive tax on the basis of insufficiency of hypothesis or even more so because of contradiction (*no bridge*, in short), then property *d*), as formulated by D'Addario, also fails because of its non-compatibility with *no bridge*, here demonstrated.

All this must lead to a greater scientific tolerance, and this means the enlightened consideration of horizons in terms of supremacy of the hypothesis in this science of ours that deals with mass or collective problems: this is so in the sense that what is legitimate in the context of *realisations* (distribution or real and mathematical graduation of the progressive tax), presuming for this purpose an *equal* psychological approach for all members of the community, must coherently also be legitimate in the context of explaining the rational bases of the progressive tax for the economic-hedonistic aspect. In other words, this is so because we are arguing about hypotheses, that is to say, the assumption of an *equal mode* of reacting subjectively on the part of individuals with regard to variations in income whose availability the tax modifies, in the unique and homogeneous appreciation of the governing class.

In this way what is a criticism directed at one of the conclusions of the investigation, of the type that is very well thought of by D'Addario, becomes an indirect logical comfort that reinforces the logical legitimacy of the hypothesis that appears to be most appropriate – among those already closely linked to the hindrance of *no bridge* – when faced with mass phenomena. In the same way in which a partial psychological presumption dominates the demonstrated rationality of the mode of statistically distributing the progressive tax [property *d*)], so must be admitted the hypothetical vision of the most frequent mode of argumentation hypothesised by me in this chapter as being specific to subjects with regard to the wealth at their disposal, in the explanation of the rational bases of the proportional and progressive imposition and, in particular, of the switch from proportionality to progressivity.

It is understood that this explanation remains limited to the economical aspect of the problem of the distribution of the imposition coherently with the concept of public finance economy that I have exposed.

CHAPTER IV

ABOUT THE PRINCIPLE OF “CONTRIBUTIVE CAPACITY”

I.

ATTEMPTS TO GIVE MEANING TO THE CONCEPT OF CONTRIBUTIVE CAPACITY IN OBJECTIVE TERMS:

CONTRIBUTIVE CAPACITY RELATIVE TO THE BENEFITS (EFFECTS) OF PUBLIC EXPENDITURE

In the wide treatment of the subject that was intended to explain, with the help of suitable hypotheses, the mode of distribution of taxes used to distribute the cost of services called indivisible (by definition), the concept of contributive capacity was introduced. This is the basis (reason, proportion, etc.) *according* to which legislators, moralists and economists would like to realise the previously mentioned tributary distribution.

To assign a first meaning to this term (contributive capacity), which *in itself* means nothing and does not shed any light on the rationality of the modes of distribution of general tributes, the concept has been linked to the mode of variation of sacrifices of utility of owners of wealth with the variation of its total, from which the public body intends to draw to cover the cost of indivisible public services.

However, creating *a relationship* between (a) the criterion or concept of sacrifice (equal, proportional, minimal, etc.) and (b) the principle or criterion of the contributive or performance capacity, for the purpose of conferring some determinate sense, in a hedonistic or subjective field, to this expression (b) that recurs in constitutional documents or in moral codes, does not necessarily mean the identification of the two principles or criteria.

Cohen Stuart, who as we have seen has mainly analysed the subjective variable (sacrifice of utility) for the determination of the problem of the mode of distributing taxes, having admitted a definition of equality, coordinated the two criteria or principles, (a) and (b). Indeed, for this author, the “principle of the imposition according to the contributive capacity” “does not give a measure for the distribution of the tax, but rather it is useful to determine the object of the tax”. “The measure of distribution is given on the other hand by the theory of sacrifice”. And the principle of the contributive capacity, that Cohen Stuart coordinates with the principle or the theory of sacrifice, is expressed in this way: “taxation according to contributive capacity, such as an equality in terms of sacrifice is derived from it” (*op. cit.*, p. 445).

Whichever way the relationship between the two principles or criteria or concept is perceived, it is certain that, by hypotheses some will consider to be arbitrary, there has been the attempt, through the utility variable, to determine the concept or principle of contributive capacity, otherwise empty and prone to tautological statements. This capacity is the reason why it is opportune to contribute to public expenditure, *a truism* that is characteristic, as we have seen, of the declaration of the Italian constitution. The hypotheses regarding the variation of utility may well be considered to be arbitrary, and the explanation of the mode of thinking of the State in the choice of modes of distributing tributes might be regarded as formal. It is, however, certain that a specific logical significance has been imparted to the criterion of contributive capacity either subjectively or by imagining the hedonistic evaluations of the individuals with regard to the wealth or income at their disposal.

In the attempt to give meaning from this point of view to the concept of contributive capacity and to the criterion that it is meant to represent, it was felt that the relationship between tributary contribution and the consumption of public services or utility of services for the members of the community was neglected. Indeed, *given* a definition of justice or of equality, the coherent deductions of these with regard to the modes of distributing tributes on the basis of the hedonistic variable of the subjective utility have been considered.

However, another rational attempt to determine the criterion of contributive capacity has been carried out – in particular also by the author – in an *objective* manner, in other words taking into account, in a further approximation and with direct observation of the facts, relating the wealth or income of the taxpayers with the presumed and actual consumption of public services on the part of the taxpayers, as individuals but mainly as groups of members of the community. I am referring to services that, by definition and in a first approximation, appear to be *indivisible*.

Otherwise, after the explanation given of the mode of distributing taxes by introducing the hedonistic variable (subjective utility), it would be necessary to abandon this principle or criterion because it is misleading and undetermined, or an “empty box”, as some have defined it.

I quote, for example, the following conclusions, concordant with this view, reached also by the indicated authors:

a) E. Sax (in *Principii teoretici di economia di stato [Theoretical principles of State economy]*, Bibl. d. Econ. [Economist Library], Series V, Vol. 15, p. 372) states that “with that principle” it is not possible to “say anything positive from the economic point of view”;

b) Graziani, at the end of a reasoned review of hedonistic visions (*Istituzioni [Institutions]*, p. 267), considered the links of the concept with the quantity “income”, stating that “from whichever point of view contributive capacity is considered, *in itself* it does not provide criteria of distribution of the tributary burden”.

c) The concept of contributive capacity remains undetermined, Borgatta stated in his lessons (*Appunti [Notes]*, 1932–1933), arguing that “considering earned income, net assets, consumption and free transfers as indices of this capacity does not in any way indicate how the tax should be measured against the same indices, nor does it justify either the proportional or the progressive tax”. He continues by saying that “to reach these conclusions it is necessary to take into consideration the subjective utility of income”. In other words, as I have observed, a first determination of the contributive capacity has been offered by the utility variable whose sacrifice we have considered, on the basis of the equality criteria examined.

d) Other authors, however, insist on the emptiness of the principle of contributive capacity included in this concept: Myrdal certainly states that “the expression *contributive capacity (or ability)* in A. Smith is really a rather subjective and, in a way, demagogic statement, without any deep meaning”, They don’t look at this as a contribution to the anthology of sceptical conclusions tending to consider the concept of contributive capacity in itself, or in its absolute sense, as a “myth” likely to induce serious errors.

Therefore, the institution of a relationship or reference of this concept of contributive capacity to the presumed or actual consumption of public services, even if defined as indivisible, to identify *at least* the typical cases of differential consumption when technically possible, has appeared to be necessary. This has been considered as conferring some meaning to this principle in the context of evaluations gravitating in the field of the *objectively determinable* or at least presumable quantities, and as explaining the numerous special tributes that have such a rational basis, other than variations of general tributes.

However, also in this logical order, it is possible to make space for assumptions of *first approximation* such as the one by De Viti De Marco, notable for the significance assigned to it in his vision. To resolve the unknown quantity represented by the individual consumption of public services (which is determined by the demands for them by individuals for *non-tributary* revenues) De Viti De Marco, like other authors, assumes that all members of the community are users of general public services and that the income of each member of the community is the index measuring his demand for general public services, that is to say, those that are defined as indivisible. As the difference between the assumption and reality is clear, De Viti De Marco hypothesised that the *average* consumption, in time and space, of (indivisible) public services is proportional to the income of each citizen.

English authors, such as Benham and Dalton, consider the starting point of this argumentation to be inaccurate: Dalton simply defines the benefit derived by individuals from expenditure for the purpose of the common good as *unverifiable*.

In any case De Viti’s assumption can be accepted as a first approximation in generally explaining the arising of the imposition and for the solution of problems of pure theory that, as we

will see, pivot on this general hypothesis. It is true that Edgeworth considers the principle of contributive “capacity” or “ability” as belonging to the domain of pure theory, “in a rather objective way” (p. 325, *op. cit.*). However, the hypothetical thinking as such, as we saw in the *Introduction*, logically legitimises the deductions that we derive from hypotheses of the type of the one that, in a first approximation, we recognise in De Viti’s formulation, even though it fails further logical and historical approximations.

Indeed Borgatta, for example, who like me intended to proceed to further approximations, when faced with the assumption of a relationship of proportionality between the magnitude of the income and the consumption of indivisible public services, admitted that it “dispenses with the need to calculate the economic value of services individually consumed, and establishes at the same time the relationship of consideration on the basis of an *objective* criterion”. However “this generic assumption” – he added – “is not supported by any specific evidence: there are services for which it is more rational to presume that the overall protection offered by the State is constant (protection of life and of personal integrity, military defence); there are services, whose benefits are assured to various forms and levels of incomes, which vary (at the same level of income) according to the nature, mode of production and consumption of income, place of residence of the taxpayer, pleasures and subjective feelings, etc. (viability, remediation, social assistance); there are services that directly benefit some groups, while their benefit for others is not apparent and important” (*Appunti [Notes]*, *op. cit.* pp. 250-253).

After having counted the cases where the assumption of proportionality of consumption in relation to income could provide positive criteria of distribution, on the basis of territory, he does not believe that it is possible to derive precise criteria for the distribution of the tax from the contributive capacity conceived in this way.

This is a conclusion on which many agree, even those who tend to empirical solutions for these problems, like Beuhler, to whom I will make reference later, who considers the reference to objective indices of the contributive capacity (income, for example) for the distribution of tributes as a reference to a presumed, not a real contributive capacity (*op. cit.*, p. 322). In my view, this represents an *apparent* improvement with respect to the criteria of the cost of the service and the benefit that taxpayers derive from it. “However, this principle of contributive capacity indicated or measured by objective elements leaves problems of justice (or of equality) in taxation largely unsolved” (*id.*).

Let’s keep in mind that, more for reason of economic logic, the assumption of the proportion between objective indices of contributive capacity and the consumption of public services has been expressed, as a first approximation, for technical reasons or practical difficulty in determining the effective, or most probably credible, of public services on the part of individuals and groups of the community. Those who have closely followed De Viti De Marco’s vision now have the possibility to note that the special public service is only *technically* different from the general one. Still, as we saw at the time, in cases of taxes and betterment taxes, the State controls the group consumption more closely than that by the community.

All this is important for what I will say later. That is to say, the true rational solution of the problem of the distribution of the cost of public services is found in special taxes, a system which allows for a more rigorous management of the use of public services by groups and regions. This tells us that the general tax is used not for logical but for technical necessity, in other words because of the empirical difficulty in identifying and verifying the differential or specific benefits of public services for which there is no direct demand by members of the community.

According to De Viti, the special imposition is abandoned when there are adjustments of consumption between the various groups of citizens, in overall public services, in the sense that a group pays a special tax for service *A* and another for service *B*: *what then*, in the case that these adjustments do not take place or are insufficient or do not compensate for differential advantages in favour of groups or individual members of the community? Logic mathematically suggests the extension of differential, special, etc. taxation to re-establish a relationship between specific tributary duty for the similarly specific presumed or effective (when it can be approximately calculated) consumption of public services.

In other words, the defined indivisible services category does arise not out of logical necessity, but out of technical requirements: the empirical difficulty of verifying differential consumptions of public services. I will remind the reader that the legislation of many countries continues to: *a*) forecasts and extends special, particular, extraordinary and also substitute or supplementary taxes with respect to general normal or uniform ones; *β*) contemplate the “management” of the same imposition of general tributes, to neutralise in total or in part the *revenues* that derive from benefiting in a particular way from public services without contributing a corresponding differential taxation.

I had extensively covered this type of argumentation in the quoted essay (of 1936) – partially reported in the 1944 edition of these lessons – in which I had observed that the concept of a contributive capacity that is absolute or simple or considered in the sense of the hypothetical assumption of a relationship of proportionality between the indices of contributive capacity (magnitude of income, assets, etc. in monetary value) and *quantum* of consumption of public services, leaves the concept *undetermined*. Furthermore, as I have recalled earlier, this does not offer a rational norm on the mode of distributing tributes (proportional or progressive reason).

In brief, in addressing mainly academics and students familiar with the symbols, I had indicated with *y* the *absolute* contributive capacity (that is to say *not* referred to a *differential* consumption of public services), with *r* the monetary income, with *g* the enjoyment or consumption of public services, presumed as a function of income.

This leads to the expression:

$$y = f[r, g(r)]$$

which means that the absolute contributive capacity is a function of the monetary income of taxpayers, and of the consumption or enjoyment of public services. This, in turn, is a function of income, according to the hypothesis of the type expressed by De Viti De Marco (and others).

In other words, ultimately, the contributive capacity that I define *absolute* because it uses the magnitude of income as an index measuring consumption of public services, is a function of the same income, as the two functions *f(r)* and *g(r)* have the same variable in common. So that it is possible to write (as I did in the essay: E. D'ALBERGO, *Discriminazione delle spese pubbliche indivisibili ed elisione delle rendite di protezione [Differentiation of indivisible public expenditure and elision of protection revenues]*, in the journal “Studi Senesi” [Siena Studies], 1936, and in the volume in honour of Prof. Flora, Zanichelli, 1937):

$$y = f[r, g(r)] = F(r) \text{ --- [I]}$$

which tells us that the De Viti-type hypothesis, as it is generic and not suitable to the differentiation or the “rigorous management of consumption of public services” that the same author explicitly assumes to be the ideal basis for the distribution of the cost of the same services, essentially ends up not taking into account their consumption in clarifying the principle or concept of contributive capacity.

Furthermore, it does not even tell us in what *proportion* the tax should vary with the variation of the income, as $y = F(r)$ logically legitimises the type of tributary constraint

$$t(r) = tr$$

as the hypothetical base of proportional taxation when the consumption of public services is in a direct and constant relationship with the income, as a tributary constraint of the type:

$$t(r) = ar^h$$

when it is suggested that the generic relationship between the magnitude of income and consumption of public services justifies progressive imposition.

If it is wished to remove from the field the principle or concept of contributive capacity, linked to its objective indices or measures from the area of non-determination, it is necessary to leave the absolute field to get closer to the *relative* one¹⁴².

Rather than be satisfied, in a first approximation, with *always* considering the costs of public services as technically indivisible, qualified as such (indivisible) for the benefits to the community – in other words, rich in purely common benefits – it is necessary to proceed to further approximations, specifically along the path that De Viti defines as the “more rigorous management” of the use of public services.

This is so not to “advocate” new and complex systems of imposition, in addition to the general imposition, *defined* as necessary to distribute the taxes used to fund the indivisible cost of services with indivisible utility or benefits, but because it is the task of the academic to: I) *explain* the coexistence of general taxes with taxes that are special, supplementary, particular, temporarily or permanently introduced in the tributary system of many States, based on the differential verification of the consumption of public services; II) in other words to explain the reason of some variations of the formal, juridical or technical regime of taxes that are called general by definition.

The indeterminate principle of the absolute contributive capacity, that is to say, as function of income alone, does not appear to be suitable to provide this explanation as it assumes the costs and benefits of services defined as general as being effectively and technically always indivisible.

Furthermore, I have made reference to the differentiation of expenditure, not to *support* or *suggest*, in the shape of *precepts*, a specific policy, but to take into account the *effects* desired by the hypothetical legislator in a *finalistic* sense, effects that need to be rationally linked to the distribution of revenues. With a further approximation to the facts, a classification was presented by the American financier Plehn (who took into account Cohen’s criteria). I will differentiate between objectives or motivations and effects because other critics of these ideas have confused them.

From this point of view, the benefit that is derived from it (the effect, not objective, what the legislator hopes for), considering the members of the community of whom the State meets the needs, has been broken down into:

- 1) expenditure that allows for a benefit that is common to all members of the community (indivisible advantage);
- 2) expenditure that brings a particular advantage to some “classes” and that is indirectly useful to the community overall;
- 3) expenditure that benefits some “people” in particular;
- 4) expenditure that benefits some people exclusively.

It was thought that the expenditure of the fourth category tends to disappear and that the historical trend is in the sense of passing from the fourth to the first category.

¹⁴² The concepts of *absolute* and *relative* contributive capacity can be found for example in Dalton’s work, with a completely different meaning. He considers as subjects two communities that need to contribute to a common expenditure. For each of them there is an *ability to pay* or *taxable capacity* that, in absolute terms, according to some, is measured from the overall production of a country less what is necessary to maintain the population at a level of subsistence. However, this concept is not useful in determining how two countries should contribute to the cost of something they both benefit from. Dalton states that the concept of absolute contributive capacity does not resolve the problem; that is to say, it does not offer a specific solution to the problem. He thinks of relative contributive capacity in the sense that, if a common expenditure increases, the proportion paid by the wealthier taxpayers must increase and that paid by the poorer taxpayers must decrease. This brings us back again to the comparison between the rich and the poor, even if it is extended to entire communities, as it is apparent from the examples of common expenditure between nations, that is to say, in a field that is *independent* from that which here leads us to wanting to find an explanation: 1) for replacement and supplementary tributes, mainly of a real nature, with? respect to those that are normal and general; 2) for the management of these to place in correlation the indices of the contributive capacity with the facts of consumption of public services in the context of individual States. Indeed, as it has been seen, the problem of the progressive levy (distribution of the levy between the rich and the poor) has been kept separate by that of the simultaneous participation to the consumption of public services.

Furthermore, Dalton’s concepts may be applied to the comparative pressure both of overall and specific impositions, of different States vis-à-vis a common expenditure.

However, it has not been observed that the first (see number 1) category, with respect to the real phenomenon, is an *abstract* category to which some exceptional historical cases correspond. And expenditure, for so-called indivisible needs (for their effect), assume mainly the characteristics of the second category, and sometimes the third category, of Plehn's classification.

Once this has been noted, as I highlighted in the quoted essay, public indivisible expenditure *discriminates* often in favour of "groups" of the community, giving rise to protection revenues for them, in the form of a relatively lower cost or greater production of income or lesser income expenditure in relation, precisely, to *differential* consumption or enjoyment of public services.

The specialisation of the imposition in relation to this process is not new, as the examples of fiscal institutions corresponding to the denomination of betterment taxes and of special taxes quoted above demonstrate.

[Normally, however, groups that benefit in a differential way from public services and from which the public body "claims" special tributes in *consideration*, are historically identified through territorial *constraints*¹⁴³ juridical, generally associative¹⁴⁴ and, as exceptions, economical (the case for example of excess profits determined by war expenditure).

Furthermore there are the normal and in any case frequent cases of taxpayers not tied by associative constraints but by abstract elements, historically changeable, contingent and extrinsic, determined by the same process of differentiation of the public expenditure for services presumed to be indivisible (such as belonging to determinate income classes, to the category of producers of goods and services, to that of exporters, of suppliers to the State, of estate assets owners or specific types of moveable wealth, etc.). These often take advantage, systematically and in a *differentiated* way in comparison with the general public, for some period of time, of general public services, without their contributive capacity being considered with regard to the particular consumption of specific services funded by expenditure defined as indivisible but not always technically so.

This is a way to confer determination on the concept of contributive capacity, placing it *in relation to the differential consumption of public services*, and for this I define it (in this sense) as *relative* contributive capacity. It is the logical spirit of taxpayers and special taxes, extended where technically possible to a sector that, in a first approximation, regards general taxes and only these and not also the differential "management" of them (as the example will clarify) and their integration.

In comparison, if we wanted to use symbols, which are proven to clarify concepts for students, as the results of studies suggest, the relative contributive capacity (y') can be expressed with

$$y' = f[r, g(r, s)] - - - \text{[II]}$$

where s expresses the particular or special advantage that the public expenditure brings to given groups or classes of taxpayers with respect to the rest of the members of the State community. The value of s in quantitative terms can be given by the *lower cost* or by the *super income* into which the particular benefit of the indivisible public expenditure can be *translated* (effects), when taxpayers are considered as producers of income; or and also the *lower expenditure* in individual budgets, when the same benefit *is resolved* (effects) in replacement of a public expenditure and a private expenditure, real or virtual, of the taxpayers, as consumers of income.

II.

DIFFERENTIAL TAXATION OR ELISION OF "PROTECTION INCOMES" IN THE LIGHT OF THE "PRINCIPLE OF RELATIVE CONTRIBUTIVE CAPACITY"

¹⁴³ The case, for example, of the betterment levies on given groups of estate owners (see Chapter II).

¹⁴⁴ Among the examples are those of trade unions, councils, chambers, etc., as they are organisational processes through which the State also pursues general interest objectives and that benefits some individuals in particular, as members of specific groups.

The scope of the expression [II] can be widened when the differentiation of public services in general is considered as well as the differentiation of the expenditure (s)¹⁴⁵. The reference is to general provisions of customs and administrative protectionism, which can be taken into account for the theory that we are considering, with regard to public expenditure, for the formation of incomes deriving from public protection”, susceptible to particular taxation. It is clear that the validity of the concept of relative contributive capacity is *limited* with respect to that of the principle in the expression [I]. This can be stated *not* from the *logical* point of view but from that of *empirical acceptability* and, in terms of quantity, of the process of differentiation of public expenditure incurred for indivisible public services in the strict sense. However, the merit of the expression [II] of the concept of contributive capacity consists in placing as the *determining element* in the otherwise meaningless concept of the principle of absolute contributive capacity, which is “formally” more general in comparison to others, but is based on extremely hypothetical or first approximation *assumptions* and on arbitrary premises. Indeed no account is taken of the developments of the real phenomenon of differentiation of public expenditure, which as we have seen is equivalent to not taking into account expenditure generally, in considering the criterion of contributive capacity.

Of the two great sectors of financial activity that are affected by expenditure, I have considered the following as examples:

I) Expenditure for *economic development* (roads, remediation and public works generally, grants and subsidies for industry, grants and warranties for exporters, etc.) that has as its effect an increase in the production of revenue.

Expenses and provisions that have as an *effect* or as repercussions or reflex (and not only as objective) the increase of production in specific sectors through public expenditure are incurred in the case of organisation of military defence. Expenditure outside the State budget is charged to consumers and taxpayers, through protective duties that intend to facilitate the start and expansion of manufacturing, agricultural, etc. industries. From the point of view of the *effects* of this, it is *as if* the State collected tributes and used the revenue for awards and subsidies. The difference in the case of awards is essentially *technical*.

II) Expenses for “social services” (unemployment, pensions, education, hospitals, marine and mountain settlements, dwellings, etc.).

As these are expenses for services or goods that – to use De Viti De Marco’s words and refer coherently to the State function as a factor of production in the conventional sense (*Introduzione [Introduction]*) – are instrumental for production and conditional for the consumption of goods produced by the private sector. Many of the general services, “benefit directly some groups more than others, but indirectly they benefit all” (De Viti).

I wanted to use De Viti’s words and not the equivalent ones I used in my specific essay to differentiate, as hurried readers are unable to do, between *objectives* (expenses aimed directly at satisfying needs of the community) and *benefits* or *effects* that indirectly or on average benefit the community, but that immediately or directly (even in a temporal sense) benefit particular groups. In this sense Plehn’s above mentioned classification is admitted: that is to say, benefits are the effects of the financial activity.

The investigation of effects of this type of expenditure, of which Sykes, Shirras and Dalton have dealt with abroad (see my quoted essay), contributes to the evaluation – I wrote – of “the *repercussions* directed to individuals as belonging to distinct groups of social classes, as well as indirectly in favour of the community, of the two typical cases of differentiation of the public expenditure indicated above with illustrative notes”. Clearly they do not constitute the entire case history, which is forever renewed with the historical extension of the State intervention, of which theories intend to explain the logic for the part which is scientifically organised.

“*Generally speaking*, public expenditure has effects on production and on the distribution of wealth. In particular, according to the orientation and differentiation, it modifies the capacity to work and to save and influences the disposition to saving, and the effects on the efficiency of workers is

¹⁴⁵ The formula [II] could become $y' = f[r, g(r, s, z)]$ where z represents the differential advantage deriving from legislative provisions, from administrative or customs protectionism.

extended from current to future generations. Indirectly there are benefits for the community". More apparent are the effects of the participation of financial activity on production combinations, with creation of differential revenues due to this State interference.

In any case, the growth of State expenditure and of other equivalent forms of differential protection requires *time*; this is a factor that I have underlined but that has not always been understood, as I will shortly make reference to. Indeed, over time, State or public initiatives contribute to the creation of surplus income that translates into expenditure or equivalent actions of differential protection, by providing for collective needs (general protection). That is to say, differential revenues or benefits are created in favour of groups.

Over time, replacing private with State expenditure in the individual budgets of classes, for example lower classes, with various forms of assistance, the *real* income of these same classes of people in the community increases, or their capacity to obtain monetary income is increased, in a greater way than would have been possible without the differential favour or protection conceded in a *first* instance.

In other words, financial activity lays the rich bases for a *subsequent* differential taxation or a partial or total elision of protection incomes. Let's keep in mind that we are still explaining the institutes and tributes that are becoming more common in the legislation as well as differential variations of the extent of normal taxes, with the same function assigned to *ad hoc* taxes (I have generally made reference to the meaning of "management" of normal tributary revenues and of expenditure, in the quoted essay).

"In modern States, theory and practice consider the taxation of *protection incomes* as just. It is therefore not possible to ignore d'Albergo's thesis on differential taxation where its assessment is easy, *especially in the sector of expenditure for economic development*". One of his attentive readers so comments¹⁴⁶, after having clearly summed up the logical premises of the relative contributive capacity, an expression I used in 1936 in an attempt to give some content to this expression, otherwise devoid of meaning.

He does however add two observations: *a)* the adoption of a rational taxation system of normal income may perhaps make differential taxation superfluous; *b)* as these "incomes" originate from a policy aimed at encouraging the development of some social productions or initiatives, their taxation might induce the interruption of the stimulated activities: "the two policies may be in contradiction".

I will remind the reader that my theory does not advocate reforms but rather it is an *explanation* of how States operate so that the mere reference to specific cases offers a first response to these cautious observations that have stimulated less cautious observations in others, and that I keep in mind simply to clarify my thinking, in the case of some students nursing similar doubts.

The response to the first observation was obvious in the science that coherently explained the legislation dealing with these subjects: for this reason I had not insisted on this in 1936. For example, with regard to the taxation of surplus values due to public initiative (public works specifically or generically likely to create surplus value), the same Borgatta gave the example of an exceptional event (war, etc.) that suddenly increases the collective demand of products offered by industry.

After having identified, according to the obvious science, the basis for a differential taxation, in light of the contributive capacity (that I have defined as *relative* to the differentiation of the benefits of public expenditure), Borgatta had already responded to those who, in the long-distant theoretical past, had objected that "if there is a permanent general tax on the income from assets, then also the increase in the value of the capital is automatically taxed".

Given the example of a sudden doubling of the level of rents, Borgatta (*Appunti [Notes]*, pp. 147–150) added that the justification for the differential tribute on increases of capital value [that is, the present value of the higher income] we must not search the increase of the contributive capacity (in fact, in the case of an increase of ability to pay, a higher tax burden is already automatically). This could be because of the conditions (specific or differential State tender) in which the surplus value is formed in part without adequate personal input by the owner of the assets; according to Borgatta this

¹⁴⁶ Gangemi (*op. cit.*, p. 425–526 and 473–474).

is because of the incidence of the tax on whoever is the owner at the moment when the surplus value is formed.

In 1936 I also wrote: “It cannot be argued that, admitting a *normal* or general system of taxation on all incomes, it is possible with it to address automatically the differential benefit brought by public expenditure to given groups of taxpaying producers. This is so because this benefit would translate in the production of a *greater* income (with respect to the *time* in which there was the differentiation of public expenditure and therefore after the increase of differentiating public expenditure)”.

Indeed the relationship between production of income and consumption of public services is not uniform (as it is presumed only in a first approximation): the public body has supplied the external conditions for a differential income to arise. The taxation of “protection incomes” arises from the justified assumption of *greater* relative benefits that the average subject can derive from public expenditure discriminating in favour of specific groups.

Furthermore, the second reason why “normal” taxation is not “enough” to exhaust relative contributive capacity is in the obvious theory that, for at least the last half century, has explained and justified the historical documentation, in various countries, of the coexistence of general and uniform taxes on produced incomes and ordinary and extraordinary special taxes on groups of formally and technically identifiable groups of taxpayers that benefit in a *special* way from general utility services.

The readers will recall the logical genesis of the betterment tax. This affects the part of the increment in value determined by the public work: could not the public body be satisfied with normal taxation of the greater produced income (tax on buildings) or used income (tax on rental value)? The long-standing answer is against the observation, corrected by Borgatta and by me, that I recall is the particularly unanimous theory and the logic of the events according to the vision of the governing bodies of public administrations, not negatively criticised by the authoritative and obvious science that has considered it as a hypothesis.

The same could be said of the differential taxation of the consumption of viability services by enterprises that use transport: could not the State collect only the greater income produced because of the efficient viability service offered by the public body and tax it (for example in Italy) with the real tax on industrial and commercial income (of mobile wealth)?

However, the greater income arises from particular and differential participation of the public body with particular effect and benefit for some. Furthermore, the differential intervention of productivity, in this specific case, could fail because of the subjective inability of entrepreneurs to take sufficient benefit from the factor (external economy) represented by the public contribution in the context of instrumentality of the service established with public expenditure: then, as I observed in the quoted essay, the State *presumes* the benefit offered, discounting the *average* ability to make use of it in an economic context¹⁴⁷. It collects a contribution charged to those who benefit in a differential way from the service of viability, consuming it more or in a particular way.

The examples could go on (see my quoted source) with the implicit proof that statisticians and academics have not thought the two types of taxation incompatible, as some feared. Furthermore, this legislative policy *is not contradictory* and does not lead to the suspension of the stimulated activities.

As far as I know, it has never happened that someone has given up building or being an investor or a proprietor because of the burden of the specific betterment tax, and it may have happened rarely because of the tax on building plots logically based on the differential use of more public expenditure by local bodies, that create social and economic development; or that someone has given up owning a means of transport simply for fear of the road user contribution or circulation tax for motor vehicles; or that someone has given up being an entrepreneur as suppliers to the State for

¹⁴⁷ J. Stamp, in *Principii fondamentali [Fundamental principles]* (p. 434 of my translation in the *Nuova Collana di Economisti [New Economists Series]*); referring in particular to the war situation, he even considers the levy on surplus profits, motivated by the fact that the State has created the conditions to give birth to the same surplus profits. The State qualifies this levy as based on special contributive capacities as a payment on “gross” profits, “before they become real and true incomes”.

arms and military defence only because the State might elide totally or in part the protection income, due to the fact that suppliers benefit immediately and the community only in part¹⁴⁸.

Borgatta had already noted: taxes of this type do not depress production activities and economic initiatives (making reference to those about differential taxation of excess return). The same author states that surplus incomes made possible by the limitation of the competition should support the tax on surplus income, in addition to the normal one. This goes against the thought expressed by Einaudi with regard to the excess of income derived from the ownership of patents, from customs protection, from laws limiting new industrial plants, etc.: “The legislator cannot at the same time want the cause and deny its possible effects, which would be the excess of income, even if they wanted to obtain and hasten the achievement of the objective. He cannot expect to tax the excess of income and in spite of this achieve the desired results” (EINAUDI, *Miti e paradossi [Myths and paradoxes]*, op. cit., Chapter III).

Einaudi however did make the premise that the legislator wanted those patents, those industrial protections, and those limitations not with the purpose of enriching the privileged few, but for the public benefit. This is the cause of the confusion. Indeed, what the legislator coherently desires is that the *effect* does not remain or does not remain entirely in the hands of those who are the instrument for the achievement of certain general interest objectives or purposes.

When he undertakes public works for general interest *purposes* and, as an *effect* of this he gives rise to protection incomes or differential earnings, the legislator is not deluded into thinking that he has applied betterment taxes or taxes on the profits of the economic situation created precisely in their favour by using entrepreneurs, capitalists, investors, etc., to satisfy (*objective*) the needs of the community. He has not always or definitely removed the protagonists of economic life from the task that they have completed, determining indirect benefits (effects) for the community and immediately for their own profit.

The contradiction *seems* even more evident for those who do not look deeper into the problem and don't think according to economic logic, in the case of *social expenditure* or for the benefit of the community.

It would be contradictory to direct differential taxation (management of normal taxation in this sense, as we will see as a blatant case in the policy of public expenditure of the English Labour government) in favour of those categories (the less well off) whose economic condition has been systematically improved by the expenditure that I have defined as for social services.

Never mind the term *time*. Indeed, to “initiate” a contributive capacity relative to differential benefits, it is necessary to have a period of *time* during which the activity of the public body, which normally is implemented with expenditure in favour of specific classes, is instrumental in *encouraging* private activity. In rigorous treatises words have their own meaning, which cannot be disregarded without reaching absurdities.

I) So in explaining the concept of protection, used by the classics to sum up the complexity of public services provided by the State to the community, I wrote that differential benefits deriving from public expenditure can be considered to be *a concomitant cause determining a lower cost* or *a greater production* of income, and as the cause of *a lower expenditure* of individual income to *replace* a private expenditure with a public one in the phase of consumption of wealth.

II) The process of transformation of economic quantities, over time, including through their use for the purpose of improving working capacity and its productivity, was seen by Barone as a quantity to maximise, when he mediated the unilateral vision of those who placed greater importance on the variable represented by monetary saving and real assets.

This, however, is anything but contradictory to the intention of increasing and improving the process of capitalisation from which the wellbeing of people depends, a direction of public

¹⁴⁸ With regard to the effects of public expenditure over *time*, let's keep in mind – something that the would-be critics of these visions have not understood, even though unconsciously underlining the word *time* – that in the United States, as soon as the troops started to come back, the introduction of a tribute on surplus profits linked to the public expenditure that exceptionally immediately benefited State suppliers was discussed in 1950; the responsible authorities stated that the efficiency of the defence, in other words the *effect* of the service for the community, would be felt as a general rule in spite of the fact that it is the direct *objective*.

expenditure aimed at improving the conditions of life and the quality of “workers”, in the sense of their efficiency as productive units.

Barone gave an intuitive vision of this through graphic expression, representing on the ordinate axis both the productivity of work (according to curve p and q) and the magnitude of the income produced in relation to this productivity. The flow of monetary savings that “accompanies” workers is shown on the x-axis (*Principii di economia finanziaria [Principles of financial economy, op. cit., p. 160]*).

While the productive efficiency of workers remains constant, due to the absence of public expenditure discriminating in favour of a given class (in this case workers without their own capital), an increase of nl in monetary savings “accompanying” workers, that is to say when work productivity remains unchanged, leads to an increase in the income measured by RS .

However, if the monetary savings were destined also to improve the conditions of life and the efficiency of workers, for example in the measure nl , both directly on the initiative of employers, above all through the social function of the public body, and in particular by means of the public expenditure discriminating in favour of this category, it would be possible to have a higher productivity curve (q) and therefore an increase in income MT greater than RS with respect to the previous situation. (These were the ideas in my lessons in 1944).



Figura 16.

At the end of this process of transformation of monetary savings into greater efficiency of a factor, here represented by work, it is possible to coherently review thinking in the tributary field. While $Rl - t$ (t being the tax, for example direct or indirect, with specific incidence on the income of workers as providers of labour), could give as a result m , that is to say, a minimum income without contributive capacity according to historical judgment; on the other hand the quantity $Tn - t$, (with Tn greater than SR), given the tribute t here hypothesised, could represent a residual $r > m$. That is to say, in accordance with the effects hoped for from the differentiation in public expenditure, there would be the creation of a taxable matter without contradiction between social policy and fiscal policy, the first providing the logical bases for the second¹⁴⁹.

¹⁴⁹ In the English case, indeed, on the one hand there were formal benefits, such as the increase of the minimum taxable income (from 135 to 140 pounds for unmarried persons: however, taking into account the devaluation of the currency on the basis of a decrease in purchasing power of around a third, the minimum was *actually* lowered).

In the case of married taxpayers without children and especially for married people with three children, there was a decrease in the fiscal burden through direct taxation. This however was more than neutralised by the introduction of a new levy, with such organisation and such reach, before public expenditure discriminated in the social sense in favour of categories of those less well off in terms of work income.

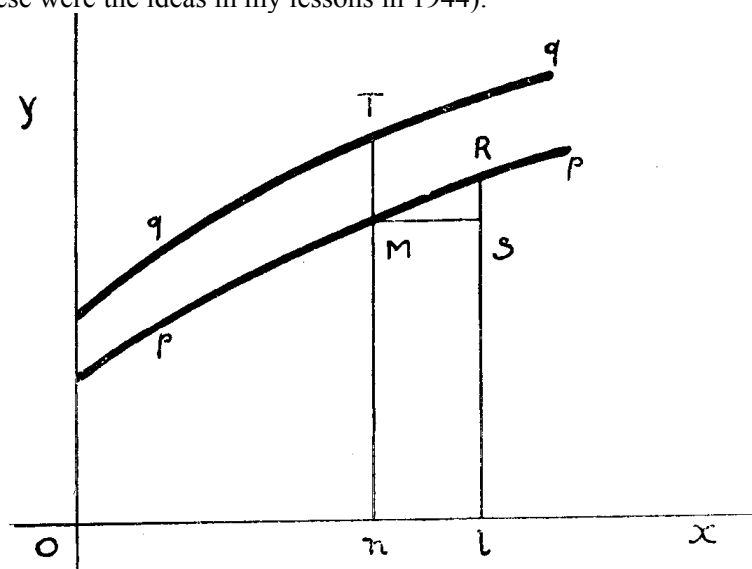
III) Facilitating subjects or members of the community, in the context of consumption of wealth in a first place, creates effects on the capacity to work and on the efficiency of workers in a second place, as well as *increasing* instantly the *real* income of those in lower earning classes. I have quoted Sykes (*British public expenditure 1921–1931*, London, 1933) for the documentation of the *fact* that: *a*) the poorer classes have benefited more than the richer ones, in the period examined (time factor), from the expenditure for social services, that have been *translated* into a relative increase of real incomes; *b*) these classes have been able to save more than richer ones, comparing the period before the war and that after it. I have also recalled Shirras (*Science of public finance*, Vol. I, 1936, p. 65) to observe the analogy of the conclusions, in comparing variations of incomes and savings and investments of the rich and the poor in the two periods.

IV) It is a matter of *profiting* from discriminating public expenditure, of contribution of the expenditure in the higher income, of expenditure that *results* in differential benefit. And so on. They are all creative processes, over time.

Borgatta did demonstrate (see: “Studi in onore di Giovanni Pacchioni” *Taluni problemi della finanza* [Studies in honour of Giovanni Pacchioni, *Some issues in finance*], Giuffrè, 1939) as the burden of tributes becomes lighter “in the measure in which the expenditure of tributes becomes an increase in the economic benefits, enjoyed by those who pay them”; and did justify “a great interest of the most recent doctrine to phenomena of public expenditure and to the study of the economic effects of the same expenditure”. He also quoted my essay (see: *Discriminazione delle spese pubbliche indivisibili ed elisione delle rendite di protezione* [Discrimination of indivisible public expenditure and elision of protection revenues], among the writings of Shirras, Pigou, Dalton, Adarkar. On his part, not used to these theoretical analyses, he did not find any contradiction other than the capacity to explain the institutions and orientations of fiscal policy that, otherwise, would remain without any explanation.

He criticises the supposition (“erroneous methodological approach”) “that the wealth collected by the State is not accounted for in the economic equilibrium, modifying in turn demand, costs, private incomes and values”. He also discusses the criterion of exemption of minimum income: “As there are State services and functions that are necessary to create conditions essential to existence and work for all classes, there would be no reason to exclude the part of income that corresponds to the cost of these functions”.

This reference is not out of place but it is useful in giving the reader some explanation of the extensive historical example in the post-war years in England, a country where, as the bibliography

Indeed, from 181 million pounds in 1946–1947, the burden of this levy, which affects clothing and household goods for more than half of its revenue, accounted for around 300 million pounds in 1950–1951. In parallel and also because of this new indirect levy (and the rearrangement of other indirect tributes), the ratio between direct and indirect tax revenue, which accounted for 64.1% and 35.9% respectively, has significantly changed. In fact already in 1949–1950 direct taxation accounted for 55.7% of the total, and indirect taxation accounted for 44.3%. Let’s think of the earlier period, when the Tories were in power (1938–1939) and we find that these proportions are practically identical to those observed after five years of Labour’s “social” experiment, in particular with regard to differentiation of public expenditure, “indivisible” by definition. Indeed, in 1938–1939 55.7% of tax revenue was accounted for by direct taxation and 44.3% by indirect taxation; that is to say, the same proportion reached by the Labour social policy. Contradiction? No, certainly not. However, the management of public expenditure, together with fiscal policy, has most likely modified the relative contributive capacity so that this base has had to be used for the distribution of the tributes, ensuring the capacity to sustain new fiscal burdens in those sectors particularly advantaged by public expenditure, discriminating in a finalistic sense.

Without introducing the criterion of relative contributive capacity it would not be possible to give an appropriate explanation of these facts that, otherwise, in fact, would appear to be contradictory where they respond to a logic linked to redistribution of the purchasing power over the entire market and with the new distribution of income.

mentioned above demonstrates, the set of effects and revenues due to State action in the field of public expenditure is rationally examined¹⁵⁰.

In fact the same type of government (Labour), with a social programme highly relying on assistance, has introduced measures that might appear to be *contradictory* to superficial observers. In 1948–1949, in an *apparent contradiction*, indirect taxes were increased even on mass consumption in budgets in which account was taken of the incentive nature of measures with regard to the increase of incomes and of employment of labour, and while (*time*) the huge social expenditure produced its *effect* (of which the new distribution of income gave an indication) for the benefit mainly of those who were less affluent. Similarly the minimum threshold for exemption from direct *income tax* was maintained at the exceptional level of the pre-war period, with deductions which were substantially lower than those of 1939, keeping in mind the monetary devaluation in the intervening years.

¹⁵⁰ I had the aspects of the post-war British financial policy examined, without any doctrinarian prejudice, in a degree theses of 1950. This highlighted not only the reaffirmation of the imposition based on the criterion I define as contributive capacity relative to the differential benefits (effects) objectively confirmed or presumed of general purpose public expenditure, in the case of *excess profits tax* on the revenue deriving from the war economic situation next to the *income tax* and as transformation of the *excess profits duty*. It also consolidated under the name of *profits tax* the special imposition (alternative to *excess profit tax*) that, as *national defence contribution* with the 1937–1938 budget law, before the war in 1939, affected the increase in industrial profits over the average of 1933–1935, deriving from the presumed differential use of the defence service (See the quoted essay E. D'ALBERGO, *Discriminazione delle spese pubbliche [Public expenditure differentiation]*, etc.).

This, however, regards the instrumentality of production facts. Let's consider what happened in the case of expenditure destined for social services or wellbeing, according to Beveridge's programme ("cradle-to-grave" assistance).

To provide for these social needs, the State has contributed with sums collected from people with higher incomes with an avocatory aggressiveness that has modified the form of distribution of incomes in England, if not the (constant, according to Pareto) type.

The statistics I have reported elsewhere, before publishing them in the "Rivista di studi economici aziendali" [Journal of commercial economy studies], were so impressive that Griziotti referred to them in treating *relative contributive capacity*, unintentionally adopting my terms and my concepts in 1936, in his essay on contributive capacity ("Rivista di diritto finanziario e scienza delle finanze" [Journal of financial law and the science of finance], 1949, N. 1). It was a matter of provisions in favour of workers financed (other than with voluntary initiatives) with progressive imposition that "for its progression up to 90% and upwards, has reduced the number of people with incomes of over 6,000 sterling from 7,000 in 1938–1939 to 60 in 1944–1945".

Let's consider the full table below:

Number of individuals by class of net income (in sterling) verified in 1938–1939 and 1945–1946 (net of other levies):

		1938-39	1945-46
from	250 to	1,820,000	5,225,000
500			
" 500 "	1,000	450,000	652,000
" 1,000 "	2,000	155,000	137,000
" 2,000 "	4,000	56,000	34,605
" 4,000 "	6,000	12,000	840
" over 6,000		7,000	45

The figures go beyond the decimation of the pyramid or of the higher part of the triangle that represents geometrically the distribution of incomes (as we have seen with regard to the progressive levy in the previous chapter). The flattening of the expected shape is however accompanied by a significant increase in the number of those with lower or average incomes, in great part brought about by the increase in those whose income used to be less than 250 sterling.

Let's not go too far in the interpretation of events, to avoid the linking of events that are not necessarily connected to each other. It does however support the belief that public expenditure policy has given rise to "protection incomes" and the set of measures to elide them, in part.

I wanted to insist on this notorious case to highlight how the vision of general economic equilibrium and of the variations of interdependent quantities, *over time*, lead to the understanding that it is not contradictory to ask those who have differentially benefited from the effect of discriminating public expenditure in their favour (*first place*) to pay in a differential way (*second place*).

It would be opportune to reflect on De Viti De Marco's words, when he illustrates the policy of *special* or class *benefits* with expenditure in favour of lower classes. The illustrious author demonstrated: 1) that it results in an increase for *all* taxpayers and, with progressive taxes, in a trend levelling of incomes; 2) how it becomes impossible in the long term to avoid the fact that those classes who benefit from expenditure, and were *before* exempt from contributing, are the same classes as those who pay for it.

Smaller taxpayers may react to this, he wrote in his *Principi [Principles]*, compared to the proletariat; these will not, when they are advantaged by public expenditure to the extent that this even changes the social structure. Classes who benefit from this cannot be surprised about variations of the impositions charged to them, in the spirit of elision of protection incomes, when the purchasing power to provide for a given public expenditure, in total or in part, has been transferred to them. This is logical mathematics, *given* a certain level of essentially unchanging or increasing level of expenditure. It is a sociological remark, according to which the group benefit is inseparable from the collective one, when the legislation clearly denies these gratuitous statements on the basis of economic logic that places the instrument of the elision of benefits of the common action (expenditure) in the hands of those who, like groups, are instruments of general wellbeing, that does not explain anything¹⁵¹.

To leave aside the time factor with regard to the *effects* of the distribution of wealth generated through the management of revenues and expenditure is a mistake because of the implied belief that the State behaves in a contradictory manner, like a farmer who, after the seed is planted, the fertiliser added and irrigation completed (public expenditure, in the example), *immediately* repents and takes it all or part of it back. If he does however wait for the *effects* of the sowing, with the help of natural humus, fertiliser and irrigation, he then reaps a greater crop, where he has applied his fertilising action. Taylor seems to have understood this well (*The economics of public finance, op. cit.*, p. 142) in his conclusion of the *effects* of public works and programmes of social safety and collective wellbeing (including education, assistance to young people, nutrition, public hygiene, etc.). Development projects, implemented by using public resources, not only increase productivity and the quality of life in the "areas" in which they have been carried out, but also open opportunities of investment for private parties. Furthermore, the "expenditure for social wellbeing acts as an irrigation system that distributes the purchasing power widely over the entire country, increasing the level of expenditure on consumption and productive activity as its effect (intended over time)".

These ideas were partly implicit and partly explicit, as I have recalled, in the approach to the concept or principle of the relative contributive capacity. In 1949 Griziotti not only used terms and expressions and identical concepts to this in the quoted essay, but in 1950 (December issue of the quoted journal) he also makes them his own, dealing with the *principle of the benefit* and the *imposition of fiscal revenues*, using a title that paraphrases the one I adopted in 1936. He makes professional reference to my investigations and makes these expression his own, with the satisfaction of the writer who may differ only in terms of his interpretation of some concrete institution or some example derived from antique and recent legislation.

To demonstrate the inventiveness of the criterion and of the explicative approach of the principle of the relative contributive capacity, I recall some examples derived from a legislation introduced in recent years or in discussion, as well as that of the differential taxation of profits deriving from re-armament:

¹⁵¹ If a more or less arbitrary definition of collective interest were sufficient, and in the case of the simplistic sociological fiction were appropriate, it would be necessary to bury the legislation, in other words the facts, and the theory that gave it an explanation in the context of special and differential taxation that has for some time concerned statisticians and scientists worthy of the name. They continue with their gnoseologic work, concerned only with avoiding that pseudo-analogous logical argumentation that arise in the minds of those who deal with the close examination of tributary problems of this type.

a) The same English legislation has introduced, on Labour's initiative, a *special contribution* on incomes from investments that are presumed to be advantaged by the *incentive* policy that directs the English budget (revenues and expenditure);

b) The Italian legislation (28-4-1947, no. 330) has introduced a tax on the contingency profits of foreign trade, of which I have discussed the partiality in another context. I will not mention other well-known extraordinary taxes on the profits deriving from the economic and political situation in the post-war period;

c) The *tax on inflation* is discussed. This tax, which was first introduced in Germany after the First World War, aimed at elision of protection incomes deriving from public expenditure implemented *also* through exceptional and excessive emission of (money) notes. This tax did not aim to hit the "apparent" surplus profits that Einaudi refers to (*Miti e paradossi [Myths and paradoxes]*, *op. cit.*, pp. 82–83) but effective *differential* earnings deriving from the net balance in favour of those operating in the economic field at given times, when α) costs (rents, taxes, tariffs, salaries, etc.) and β) unprofitable items (certified debt, etc.) do not change in the same way. The motivation that in α) gives content to the logic that, in part, was at the basis of the Italian tax of 1936 on estate assets, while the second reason β) explains the German inflation taxes of 1924–1925¹⁵².

All this is briefly remembered to prove the inventiveness and the attitude of the principle of contributive capacity, as I conceived it (*relative*), to explain facts and laws that otherwise could be considered to be arbitrary.

These references demonstrate that the category of *indivisible* expenditure, of indivisible costs, of indivisible services whose historical content is variable as a function of the capacity to ascertain the contrary, that is to say, to identify sectors of differential use of public services. As illustrious authors have observed, the long persistence of general taxes is a matter of *technical* powerlessness, in other words the difficulty of a distribution according to the criterion of special imposition.

¹⁵² With the decree of 24 February 1924, the German government introduced four special tributes, applicable to the *benefits* that some large categories of debtors were enjoying, following the *devaluation* of the mark that, as it is known, had reached levels such as to practically nullify debts incurred, at their time, with good money. (It is sufficient to remember that in November 1923 the gold mark was equivalent to a thousand billion paper bills; on foreign currency exchanges the quotes were even higher).

This decree came to regulate the widely disputed issue of the revaluation of credit towards which jurisprudence was positively moving, after numerous controversies, having recognised that the repayment of mortgages, for example, for buildings that were still nominally owned by the mortgagee, with currency of nominally unchanged currency whose purchasing power was however practically nil as being an act against good faith.

1) With regard to shares loans, industrial companies, which had generally benefited from the devaluation, were subjected to a levy equivalent to 1.7% of the original gold value of the shares; for those already reimbursed for a sum lower than the level of revaluation fixed in the same decree (15% of the original gold value, so with a limitation of the loss to 85% in real terms), the levy also absorbed the resulting difference: in other words, in this latter case, the State replaced the private creditor in the enjoyment of the revaluation granted.

2) With regard to mortgages, the benefit created by their devaluation was hit with two levies, respectively targeting mortgages on rural land and buildings.

The technique of the first levy was analogous to that of share loans, that is to say: 1.7% of the original gold value for re-evaluated mortgages and the absorption, for those already paid off, of the difference between the amount in paper marks corresponding to the level of revaluation (fixed at 25%, normally, by the law of 15 July 1925) and the amount reimbursed.

3) The other levy, the so-called "rent" levy, was designed so that the residual revenue net of the levy left to the owners of houses was not less than 30% of the income from rents in the pre-war period. Indeed, because locations, after an initial period of restriction, were subject to free negotiation and gradually adjustment to the monetary reference values, the owners of houses came to benefit from increases due to the economic situation as a result of the devaluation of mortgages on those buildings.

4) Finally a special levy was established for application to benefits enjoyed by State debtors, mainly for the supply of timber, through the postponement of the relative payment in periods of very high inflation and, consequently, of strong monetary devaluation.

However, there is no reason to add intellectual powerlessness to the organisational powerlessness that regards facts, in other words, history, with criticisms of the criterion of relative contributive capacity.

Wicksell had stated that the “principle of service and consideration” is “justified any time it is *applicable*”, after having: α) demonstrated that “calculating the tax in such a way so that it is exactly tailored to the use that an individual makes of the public service” is only a matter of empiric difficulty, and β) held that the principle of consideration has the advantage, at least, of maintaining a certain contact with the other side of public economy, that of expenditure. He would like to extend the principle of the interest or of the “economic equivalence” or of the “benefit” obtained by members of the community to all State activity, where it deals with the “rational limitation of expenditure”.

And yet he considers as “victorious” in practice the criterion of contributive capacity (which I have defined as *absolute*) in the sense here indicated and demonstrated to be indeterminate, compared to the other theoretical principles for the explanation of the distribution of taxes. It is a victory of light over darkness. One part of this reverberates in the field of imposition, through the criterion of the contributive capacity *relative* to the events with verifiable approximations, at least in the sense of more or less. The association between the principle of contributive capacity and the benefit that Seligman would have liked to suggest finds no development at all in his treatise. This can only be implemented with that of the *relative* contributive capacity that, as it is demonstrated in these pages, appears to be inventive and suitable, in the judgment of the masters of finance that have welcome it, to justify tributary events and laws that would otherwise have no logical interpretation and explanation from the economic point of view, which is taken into consideration here.

CHAPTER V

ABOUT SO-CALLED “ECONOMIC”, “NEUTRALITY”, “PRODUCTIVISTIC” PRINCIPLES AND OTHER CRITERIA FOR THE DISTRIBUTION OF GENERAL TAXES

I.

ENRICO BARONE’S “ECONOMIC PRINCIPLE”

In the field of distribution of tributes, Barone believed he had expressed the “economic principle”, based on the Paretian empirical law of distribution of incomes (in *Principii di economia finanziaria [Principles of financial economy]*, Zanichelli, 1937, *loc. cit.*).

I will start by saying that he based himself on the Paretian uniformity, expressed through a “carelessness of language”, as F. Vinci defined it (*Sulla legge della distribuzione dei redditi [About the law of distribution of revenues]*, in the essays in honour of F. Flora, *op. cit.*) in recalling how it had been highlighted by Bresciani-Turroni and by D’Addario.

Indeed, Barone adopts the following uniformity, expressed in Pareto’s *Manuale [Manual]* (p. 373) as follows: “Every time total incomes rise more rapidly than the population, that is to say, when the average income increases, the following effects occur, separately or together: 1) an increase in the minimum income; 2) a decrease in the inequality of incomes”. So had Pareto already concluded in the *Corso [Course]* (Vol. II, no. 965).

[Those who have followed courses of political economy in Amoroso’s volume *Economia di mercato [Market economy]* will have found a clear demonstration of how Pareto’s second proposition proves to be turned upside down, in the sense that with the *growth of the average income*, measured on the natural scale – that is to say, common to all distributions – *the inequality of conditions increases*. In this sense this uniformity is by now obvious to statisticians and it is logically compatible with the progressive direct tax, as will be seen]¹⁵³.

Barone, in fact endorsing Pareto’s statement, formulates the “economic principle” in these terms: “*in the distribution of the fiscal burden, the system that is able to achieve specific requirements, with the fewest obstacles to the development of the average income, is to be preferred*”.

The correction of the statistical uniformity presumed by Barone is not devoid of meaning with regard to theoretical-fiscal problems, as can be observed using Lorenz’s well-known diagrammatical representation.

Indeed, as the average income increases, the ratio of the areas increases, as we move away from the line of equal distribution *AC*. (The percentage of tax is shown on the abscissa while that of incomes is shown on the ordinate axis.)

For an average income *X*, the ratio of *ACN* to *ABC* is less than that of an average income $X' > X$, as the area *ACE* will need to be compared to area *ABC*.

I am using this representation because it was used, for example, by Samuelson to demonstrate that the effect of the progressive imposition (that I identified for the English example) can be that of reducing the inequality of *disposable* incomes, passing from inequality *AEC* to *ACN*. It is to be understood that this is on the basis of the hypothesis that the tax has not been redistributed. It is a problem of degree of progression in a first approximation, and therefore of a policy of redistribution of public expenditure.

However, this is an indirect effect of the imposition, that is to say, a different problem from that formulated by Barone, for whom the imposition must impede as little as possible the increase in the average income, in the (mistaken, as will be seen) forecast of a *direct* decrease of the inequality of incomes for the increase *r* (average income).

¹⁵³ Vinci, considering the total distribution of revenues (including the first branch of the distribution curve under the minimum) admits that average income variations are compatible with any variation of the dispersion of incomes (quoted essay).

Let's, however, return to the "economic principle", expressed by Barone for the distribution of taxes. He reaches this point (as I had previously reported) after having criticised the "minute analyses of the utility of the various parts of income" as "devoid of any serious basis" (as if morally qualifiable hypotheses existed), and having considered them "unsuitable" (in the empirical field) in "practice" to be "translated into legislative formulae". "Arbitrariness would reign supreme" with regard to the subjective aspects of individual psychological problems. It is sad to have to insist on the criticism of this author, well respected with regard to other issues, for the progress of this science. It is not, however, possible to be silent when faced with this contradiction. He defines utilitarian hypotheses as arbitrary. However, having accepted the hypothetical concession, it is not possible to define as "presumed" the relative thinking and as unfounded the theories that derive from that, moreover appealing to reasons of applied practicality. (The difficulty of investigating different individual psyches.)



Figura 17.

The contradiction is highlighted in the conclusion he reaches at the end of the reasoning on this theme: "If we now give the name of objective finance to the finance that follows the precepts of the economic principle – and which, following these precepts, impedes the development of the average income the least and best ensures the long-term interest of all classes – and we call democratic or aristocratic the finance that, by considering the short rather than the long term, tends to benefit one class or another without being concerned with the long-term damage that is caused to the same class that it is intended to favour, by moving away from the economic principle, we conclude that it is the political constitution that causes a movement away from the achievement of *maximum utility*, or the *minimum sacrifice*, in a way, in the distribution of the fiscal burden. This is so in the sense that in the least advanced economic stages an aristocratic finance can stand withstand a greater upward pressure, and in the most advanced stages a democratic finance can push the fiscal burden much higher than would be convenient for the collective welfare".

I wanted to underline the incidental but conclusive expressions that precede and that are typical with a univocal meaning in economic science, which Barone skilfully deals with. However, whoever has read the preceding paragraph on the "principle of the minimum collective sacrifice" cannot but notice:

A) that Barone also uses Edgeworth's language, to give an example of the most important author. This latter economist deals with the *minimum sacrifice*, with which Barone associates the

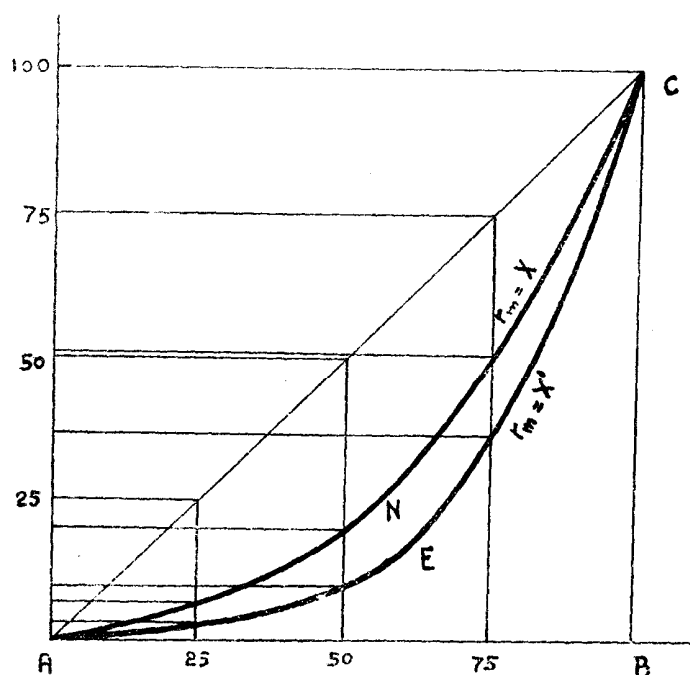
maximum utility or uses this expression as an alternative, which dictates thinking on the basis of the hedonistic variable that, in the meantime, he would like to reject;

B) Furthermore Barone is concerned with a finance compatible with the *collective welfare*.

A) In respect of the first point of view that Barone considers in the conclusive phase of his argument, it is necessary to remember that, for example, Edgeworth expresses the following concept: "The condition that the total net utility provided by taxation is a maximum is then reduced to the condition that total disutility is a *minimum*. From the condition that total disutility is a minimum follows generally that the marginal disutility experienced by each taxpayer should be the same."

In spite of the fact that Barone talks of achieving "the minimum sacrifice" – or maximum utility – I do not want here to reduce Barone's "economic principle", which is supposed to be objective, to the mainly subjective one of minimum collective sacrifice, which Edgeworth supports in the field of rational explanation. It is sufficient for me to state that the utilitarian variable inevitably creeps into these reasonings that try to exclude it, as Barone suggested, even though he reaches opposing conclusions.

To remain in the field chosen by our author, I recall that the quoted English economist states, among other things: "If the inequality in fortune is significant with respect to the specific amount of the tax to be collected, there will be no tax sufficient for the purpose, as it were. The solution to the problem is that *greater* incomes should be *lowered* to a certain level" (*op. cit.* 342-343). This can be read in the essay in which, again, we find that "the deduction from the principle of minimum sacrifice (an entity that the same Barone wants also in the context of objective finance) does not presume an exact relationship between utility and means. It simply presumes what is universally accepted, that is to say, that utility does not increase in proportion to means, according to Jevons' law of decreasing utility".

What's more, however, in introducing the criterion of minimum sacrifice, Barone rejects it because of concerns that are unrelated to this thinking (effects on the production that would "certainly decrease"), defining the relative doctrine as "one of the major aberrations reached in such arbitrary calculations of pleasures and pains". They are arbitrary, as can be seen, because they are hypothetical, but they are necessary if we want to discuss coherently sacrifice of minimum and maximum utility, as Barone in fact intended in the context of the conclusion of his specific study of the mass question, such as the financial one. Current philosophy, reinterpreting the classics, also recognises the "social function of the utilitarianistic principle" or the "social character of utility". It is maintained even that "collectivistic motion is at the basis of the utilitarianistic doctrine, which is a doctrine that concerns the individual because it is, first of all, a doctrine that concerns the community" (S. Castellato, *C. Stuart Mill e l'utilitarismo inglese [Stuart Mill and English utilitarianism]*, Cedam, Padua, 1951).

B) Barone's recalled incidental but conclusive reference to the category of "collective welfare", which should conciliate the distribution of the fiscal load, and what he calls the "pressure" or "burden" also leads, by inevitable logical necessity, to coordinating the previously mentioned conceptual category with the hedonistic variable, correlated with the distribution of incomes.

Those who are experts in the area of distribution of incomes (Dalton, as the author of the volume *Some aspects of the inequality of incomes*, London, G. Routledge, reprint of 1925) consider the "system" (most likely this includes in the term "system" collection and expenditure) of public finance that ensures the "maximum social benefit" to be better. In a "strictly economic" sense this benefit is expressed in terms of *welfare* (p. 11 of *Public Finance*, quoted). The main conditions for an increase in the economic welfare of a community – according to what seems to be a generally accepted theory – are first of all the advances in production, in the sense of a greater productive capacity or productivity; in other words the attainment of a certain product for each component of the population, with a lesser effort, with a lesser waste of resources or factors such as might derive from a deviation from more fruitful employment or unemployment. (In this spirit I talk of the *productivistic principle*, essentially and coherently objective, in paragraph III that follows.)

The second condition is an increase in the economic welfare that is represented, as Dalton proves, by an improvement in the distribution of what has been produced. This results, for him (and for others I will shortly refer to as representatives of an uncontested thought), in a decrease in the

inequality of individual and family incomes. (The condition of the reduction in the variability of incomes is also taken into account in a subordinate position.)

In this way a reduction in the inequality appears to be desirable so that the revenue might be distributed in greater harmony with needs, over time, of individuals and families and with the ability to make good use of income.

Barone's argument revolves necessarily around the field of the relationship between welfare and distribution of incomes, through the interpretation of his conclusions, already quoted.

1) In fact, from the time of Marshall's teachings, material wealth welfare is measured by the flow of wealth and the possibility of making use of it, from which derives "an income of happiness in which naturally the pleasure of ownership is taken into account. There is, however, very little direct connection" – continues Marshall – "between the overall extent of that mass and total happiness". It is in the discussion of welfare, correlated to the "utility of wealth", that the English master adapts to "Bernoulli's advice", as a mode of variation of the "satisfaction that one person derives from his income", as it grows (para. 107).

2) A clear fixer of our times, Jannaccone, defines "welfare", for a single individual, as the feeling of satisfaction of the needs of his physical and psychological organism, which can be achieved with the application of income. The collective welfare is ensured at its maximum when the collective body achieves (or ensures the achievement) of the maximum net total income *and its distribution* among individuals so that the maximum possible amount of satisfaction can be derived from it. Having perceived the difficulty of comparisons between individual members of the community, the author observes, among other things, that the inequality of individual incomes is resolved in a corresponding inequality of the quality and degree of intensity of the needs that can be satisfied by them and therefore of the individual's economic welfare. Therefore Jannaccone logically outlines the possibility of influencing personal distribution in the sense of lessening inequalities, in part also through the coercive transfer of incomes from the most affluent to those who are less well off, as happens through taxation (*op. cit.*, pp. 314-336).

3) Samuelson (*Economics, cit.*), as we have seen, represented the perfect distribution (taken as that in which each percentage of the population receives exactly the corresponding percentage of total income) using Lorenz's procedure (diagonal AC in Figure 17) and, referring then to economic welfare, suggests the correction of the deviation from the social *optimum*, which he correlates to the optimum (or perfect, as elsewhere referred to) distribution of incomes with "an appropriate fiscal policy" (p. 602). In the case of the capitalistic system, from the point of view of economic welfare, he underlines the improper or imperfect distribution of incomes among the modes of moving away from the social *optimum*.

4) As my now dated approach to mass problems, in which the hedonistic or utilitarian variable is dominant, is that of the governing class judging and making comparisons on behalf of the community, I like to recall that Demaria (*op. cit.* pp. 155-161), another representative and fixer of current thinking, follows the same path, after having framed the concept of community welfare in the field of utilitarianism. As, in order to be able to judge welfare, it is necessary to compare satisfactions and dissatisfactions, he also assigns this task to the State that "coercively presumes different objectives and sensitivities for different classes". "In this case there is maximum collective welfare, if the distribution of the *sources* of moral and material emotions, based on the different psychological sensitivities attributed by the State to the various social classes, is carried out precisely so as to maximise the sum of moral and material emotions".

5) This need to correct severe inequalities in the distribution of incomes and assets, in the context of welfare, can be found in Bresciani-Turroni (*op. cit.*) who also assigns this action to the State (*op. cit.*, Vol. I, pp. 366-367).

After considering these quotes, chosen randomly among many similar ones, which the attentive reader will see are linked by a logical thread and referred to as a criticism of the expression of Barone's "economic principle", this authors arrival at a conclusion by unfortunately introducing the subjective or utilitaristic or hedonistic variable cannot lead to the acceptance of Barone's statement of the economic principle, which is, moreover, as has been seen, based on an oversight. That is to say, if the inequality of conditions increases (does not decrease) as the average income

increases, this inequality leads to the divergence from maximum utility or welfare or minimum sacrifice, the criterion of distribution of general imposition. This criterion, which acknowledges one of Barone's propositions (the exemption of a minimum income which can be justified and explained also through theories based on the subjective variable) must tend towards progression (or differential taxation of higher incomes), as an instrument of redistribution.

I start from objective data such as the distribution of incomes, and their dynamics, which are the result of complex circumstances that lead to greater or lesser inequalities. That is to say, I start from *external indicators* of welfare (such as the average income of the members of the community or the mode of distribution of the total incomes and their respective variations). Consequently these external indicators can be interpreted in light of the utilitarian theories in Chapter III, for a further insight into the maximum welfare or utility or minimum sacrifice, by highlighting the distribution of incomes.

This concept, I want to remind you, is considered in the sense of the other propositions that precede Pigou, whose thought, expressed for a similar explicit purpose in *Economia del benessere [Welfare economy]* (Vol. XI of the "Nuova collana di economisti" [New economists series], Utet) was concisely expressed, in a meaningful way from the point of view in question here, in the quoted essay titled: E. D'ALBERGO – *Sviluppi di un teorema finanziario ecc. [Development of a financial theory, etc.]*, (in an extensive summary in Chapter XI, para. V).

Links between the correction of inequalities in the distribution of wealth (incomes and assets) and "social justice" have been made from the time of Lassalle (Pareto himself, in *Corso [Course]*, Vol. II, no. 964, recalls Lassalle's correlation between the progress of welfare and the decrease in inequalities in wealth) up to our times, as is the case for example with Bresciani-Turroni (*cit.*), with Samuelson and others. For this reason the integration of this paragraph with those in Chapter III becomes more significant in terms of a rationale.

Instead Barone denied, contradicting himself, the explicative function of the hedonistic variable in the collective or mass problem such as the fiscal one. This, in the field of pure deduction, allows conclusions with universal logical value. On the other hand, considering the (wrongly linked) objective data in the empirical field, in concluding, Barone states that a response to the "preference for either the proportional or progressive taxation *cannot be expressed a priori for all cases, that is to say, for all countries and for all times*".

Furthermore, Barone's (*Principii [Principles]*, Chapter V) propositions, such as the ones to follow, move away from the rational field and converge in the domain of empiricism or of practical concerns or of financial policy (which presumes the problem of the rationality of the fiscal instrument to have been solved).

In fact, still leaving aside the mistaken statistical basis of the reasoning (which does not take into account the *direct* correlation between variations of average income and income inequalities), he suggests: *a*) the *impossibility* of taxing the minimum for existence with an imposition because it would be necessary to return the revenue through public assistance or similar means; *b*) the *difficulty* in taxing small incomes; *c*) the fact that fiscal burden would become *intolerable* if it was intended to meet the needs in the given hypotheses of concentration of incomes (pp. 63-67) only through direct and progressive taxes; *d*) the *convenience* of exempting small incomes (in countries with average small to medium incomes); *e*) *impracticable* burden on high incomes; *f*) *mild* fiscal burden compatible with graduation of progressive taxes. In this sense it is an illustration of the "economic principle" for the distribution of taxes (pp. 159-166).

To conclude, given a need or a revenue to be achieved, it is obvious that *accounting* coherence should keep track of the *given* distribution of incomes or of the dynamics of the distribution of incomes (the effects of the increase or decrease in the average income). However, this correlation between need or revenue and the mode of collecting it – *given* its amount and the distribution of incomes and its dynamics having been presumed – also presumes resolved the problem of the rational mode of having the rich and the poor contribute to *single taxes* and requires, if anything, *adjustments* in the sense of partial application of the analytical conclusion of the complexity of the real problem, as was seen in the quoted paragraph VII of Chapter III.

II.

THE NEUTRALITY OF THE IMPOSITION IN RELATION TO THE DISTRIBUTION OF INCOMES DALTON'S FORMULATION

Dalton had dealt with the *principle* of the distribution of taxes, in the sense that the imposition should “leave the taxpayers as it finds them”; in other words, it should leave the distribution of incomes unaltered by the fiscal imposition, in the sense that the inequality should not be increased or decreased, under the influence of the fiscal event, by the mode of distribution of taxes.

Literally, “leave them as you find them”, and also “do not alter the distribution of income by taxation”. Considering this, there is reason not to find novel the condition of distribution suggested by Crosara (*op. cit.*), and criticised by D'Addario (“Economia Internazionale” [International Economy, *cit.*]), of the “perfect conservation of the proportions between incomes before taxation”.

D'Addario's criticism insists in particular, against Fasiani's opinion, on demonstrating that the distribution prior to the imposition should not be, as is easily deducible, of the Paretian type. Indeed, whatever the pre-existing distribution, the principle that I have defined as that of the “neutrality” of the imposition consists in distributing it so as to leave the position unchanged with respect to taxpayers, with regard to residual income.

The condition expressed by the slogans that follow and on which the status of principle has been conferred, is actually entirely independent from the particular form of distribution of taxable incomes.

However, the pure and simple search of the formula of graduation of tax rate that satisfies this condition (a formula in which D'Addario recalls the equivalence to one of Cohen Stuart's, who, as has been seen, dealt with very different utilitaristic principles) is not the competence of financial economy. Indeed, from the economic point of view, the so-called principle of “neutrality” is in fact negative or devoid of content. From the point of view of this science applied to the financial phenomenon, the reasoning and the theory of distribution of taxation is disregarded and replaced with the aprioristic acceptance of any given empirical factual situation, or structure or constitution of any “market” revealed by any distribution of incomes. Instead of starting from a hypothetical factual situation or distribution of incomes, implicitly admitted in order to theorise about the distribution of taxes, as has been done in the various explanations of the “modes” of being of the imposition, the theory or economic explanation is rejected, and what is the implicitly hypothetical starting point is viewed instead as the finishing point (maintenance of the position of each taxpayer so that residual income remains proportionally average after taxation).

In other words, it is a mathematical exercise irrelevant to financial theory, which says nothing about the search of the mode of variation of the tax rate, compatibly with the condition that is enshrined in the English slogans quoted above. These slogans have been rekindled in Crosara's vision, and by D'Addario's criticism, from a statistical-mathematical but not from an economic point of view. As is the case with the mode of distribution of taxes so that results are gradual, this is a necessary result that derives from the mathematical link between the assumption of any given distribution of incomes and the condition that it remains the same also in respect of residual incomes after the collection of the tax.

The same casual and non-logical coincidence, observed by D'Addario, between Crosara's formula that expresses his thought and one of Cohen Stuart's, who considers something completely different, suggests that the function that indicates an increasing tax supports the caution adopted by the same Cohen Stuart, in the introduction. “Certainly: mathematics can but perform a humble serving function to political economy”. The servant, however, should not replace the “master”. Leaving metaphors aside, a purely mathematical exercise searching for necessary quantitative relationships cannot be adopted as a principle nor replace a theory that refrains from elaborating, precisely for the reason I have defined, on the “neutrality” of the imposition with regard to a factual situation, whose maintenance and consolidation becomes the purpose of the process or the independent variable, in

function of which the mode of distributing the imposition is technically or mathematically expressed, without any autonomous economic logic.

The “principle of structural stability”, whose merit of expression D’Addario attributes to Crosara – in spite of the fact that he admitted that the principle of distribution depends on the definition of the relative economic position of the taxpayers – can be sufficient to determine in accounting terms a method for distribution of taxes. The economist takes indulgent note of these demonstrations, not because they are relevant to the science, since there is no thought involved: on the contrary, he rejects an autonomous explanation of the mode of distribution of the imposition. He does so because he needs to comply “a priori” with a casual, or natural, hypothetical circumstance, the casual result of complex and not strictly economic forces such as the empirical distribution of incomes.

Dalton, who dealt with economic and statistical problems of the distribution of incomes (he is the author of *Inequality of incomes, cit.*) thirty years ago, promptly realised the emptiness and, it could be said, the shortcomings of the principle in such “slogans” and relative formulae from the point of view of financial theory.

Presenting the “principles” for the distribution of taxes, after those that we have examined in Chapter III, in which the subjective hedonistic variable of the sacrifice (of utility) was introduced, he listed the principle expressed with the above mentioned “slogans” as the “fourth principle”. He however hastens to add that to apply (to the financial phenomenon) each of them, it is necessary to presume some *relationship* between monetary *income* and *welfare* (intended, of utility) deriving from it.

Starting from the premise that the “great” inequality of incomes is resolved in the potential loss of welfare and referring in particular to the so-called “principle of constant inequality of incomes”, he immediately feels the need – that D’Addario had felt but *had not searched for in the economic field* – of a definition of inequality. He defines it in the sense of a relationship between the overall welfare achievable in the hypothesis of *equal* distribution and the overall economic welfare achievable in the hypothesis of a *given* distribution of incomes. The measure of inequality, so defined, will depend on a precise functional relationship between income and economic welfare (i.e. utility), so that a different measure of inequality will correspond to each possible relationship.

If, for example, Dalton writes, it is hypothesised that equal increases in welfare are permitted by increments more than proportional to the income (and even if it is admitted that these are ensured by proportional additional increments), each conceivable measure of inequality must satisfy the condition that proportional increases to all incomes lead to a decrease in inequality.

However, if proportional increases to all incomes decrease inequality, as it has been defined, proportional subtractions (such as tax collections) should increase it. This means that, from this hypothetically determined point of view that presumes a relationship between welfare or hedonistic evaluations and variations in incomes, *proportional imposition* must lead to an increase in inequalities of income.

If, as for our assumption, the inequality in incomes must be left unchanged by the imposition, this must be progressive in some way.

The degree of progressivity required will vary according to the precise relationship between income and economic welfare that has been hypothesised.

As has been seen, the graduation of the imposition is not *directly* linked with any given statistical distribution, but with the correlation between it and the corresponding welfare (compared with the welfare corresponding to an equal objective distribution of incomes). The subjective economic welfare factor that can be attached to an objective distribution of incomes is determining or dominant.

We cannot criticise Dalton’s vision in the way that such a concept deserves, a concept that refers to incomes and not to the properties or attitude of incomes of creating welfare or utility and that leaves aside the hedonistic variable of interest to the economist who wants to find a reference point for the presumed calculations, performed by economic experts, that the governing class is interested in. This point of view (of the governing class, which throughout my treatise is the guiding star to

which we must look to for the solution of utilitarian mass problems) allows us to overcome the *no bridge* situation that would creep into all problems relating to collective welfare.

This welfare, referring to subjects with available incomes, in Pigou's specific treatise, is defined in terms of "states of consciences" and generally, in economic works, in utilitarian and hedonistic terms, as it has been seen.

If this point of view is disregarded, it would not appear to be possible to achieve theory status, for example in considering a *rational* criterion of distribution of taxes to: *a*) maintain the ratio between incomes before the imposition; *b*) exempt the minimum for existence that, as has been seen in the examination of Barone's economic criterion, is the pertinence of the empirical, statistical and political domain. This is so unless a solution is found in Bentham's formula, illustrated with regard to the principle of collective minimum sacrifice demonstrated by Edgeworth, when units of incomes are collected from individuals to the point of leaving them, as residual income, what is necessary for minimal existence, through the utilitarian thought that makes the collection start with those units of income that have the least relative utility.

Indeed, *in itself* the existing distribution of incomes, even though it is *natural*, and precisely because it is the result of the different abilities to obtain income, of the different attitude or propensity to saving, of the diversity of initial positions and other institutional factors (as the effect of laws on heredity, etc.), is not helpful in a field in which it has been attempted at least to refer to some premises such as that of equality, in subjective terms or in terms of sacrificed utility, which has allowed coherent explanations of the calculus of the governing class for the distribution of the fiscal burden.

Ensuring that the imposition leaves unchanged the distribution of incomes, without other explanations in the sense that gives content to the economic theory on the basis of the hedonistic variable, means accepting a moral or historical judgment on the goodness, desirability or the collective utility of the permanence of such a distribution. This leads us outside the science, as I have insistently warned in the *Introduction*.

This warning is enough to help us understand how rational "principles" of distribution of tributes do not derive from the empirico-statistical law of the distribution of incomes, considered in *itself*.

In the meantime, in these reasonings, the influence of public expenditure is disregarded. This is not logically legitimate, when reference is made to distributions that are as given hypothetically, so are worthy of consideration, but that can be necessarily modified by the financial event, in the case of collection and expenditure of tributes. [The powerful English example I have previously given is significant.] Our science must give an explanation of events that are complex, when they are considered as they are. Indeed the distribution of incomes is necessarily influenced by collection and expenditure on the part of public bodies. To resolve the problem (presuming it is a theoretical one) of the non-variation of the distribution of incomes correlated with the introduction of the (progressive, in this instance) imposition, by leaving aside the influence of the distribution of expenditure, leads to an imperfect solution to the problem. This problem is not correctly set when the intention is to give procedural standards, that is to say, suggestions on the rational or logical or just distribution of taxes, especially if reference is made to the details of a concrete or particular problem for the purposes of historical simplification.

In the case put forward by Crosara and already recalled in the *Introduction*, Fasiani criticised it in detail when he observed that, by itself, the distribution of incomes that, contrary to D'Addario's demonstration, appeared to him to be Paretian and natural by necessity, with the flows of approximation to reality, because based on fiscal statistics (affected by evasion), does not allow the expression of rational and theoretical criteria of distribution of the imposition. This is so not only because it is an abstraction – as I have said before – of the influence of public expenditure but because, by disregarding the due introduction of subjective variables such as the utilitarian one to which reference has been made for some time and that Dalton feels obliged to recall to give meaning to the principle of the type expressed by Crosara, we end up formulating *subjective historical preferences* on real systems and distributions of incomes, or formulating value judgments or ethical norms. It is sufficient, among other things, to consider each distribution and in particular the set of

factors that influence the form of the Paretian curve, as analysed by Pigou¹⁵⁴ as the causes of the volume and of the distribution of the national dividend, to understand that we are gravitating towards the historicistic and not a rationally determined field in the sense in which financial economy is conceived.

III.

THE “PRODUCTIVISTIC PRINCIPLE”

A definition of imposition or productivistic finance could coincide with that of imposition of “neutral” finance. In this sense, of “fiscal tax” as opposed to “extra-fiscal tax”, the subject has been addressed recently by Laufenburger (in the journal “Economia Internazionale” [International Economy], in May 1949), adapting ideas similar to those that in the previous paragraph have been qualified with regard to the science we are dealing with. The “financial” tax – as he calls it – is *neutral* in the measure in which it does not modify the (compared) relative material situation of the taxpayers.

Laufenburger, however, is careful when he believes, for example, that the progressive tax is perfectly compatible with neutrality, as it is derived from the “justice principle”: “adapt fiscal burden to needs pressure (marginal utility)”.

This brings us to the long-pursued theoretical field, as a function of the subjective variable. For the rest, the author examines problems of financial policy, in other words, of congruity of the effects hoped for from the fiscal instrument, with respect to the objectives of economic policy; that is to say, it is limited to making reference to the differentiation of the imposition, a problem we will shortly come to.

Generally speaking, in the previous expressions of the “productivistic principle” as theoretical criterion of taxation, it has been said that a tax should satisfy the following conditions: *a*) its introduction or an increment of it *should not disturb* or *should alter with minimum friction* the pre-existing economic equilibrium; *b*) it should allow the *maximum* return for the State and similarly it should not be an obstacle to productive activity, its subsequent flow of income and the formation of savings.

Marshall, Bastable, Sidgwich, and in part Barone, De’Stefani, Mann, Moli, Terhalle and the academics of the London Colwyn Committee in the first post-war period, all intended this “principle” in this sense¹⁵⁵, while nearly all academics in the last post-war period have mentioned it with different formal expressions. It was and still is one of the cases in which the observer is induced to take into account current historical events. Having witnessed the enormous destructions of wealth brought about by the two World Wars of this century, and the consequences of worldwide crises, theoretical investigation in the field of public finance turned, among other things, to the search of fiscal forms that allow the maximum production of new wealth. However, recalling contingent events that led to renewed interest in studies of this problem does not deny the conclusive value of recent theoretical investigations with regard to the productivistic principle. For now we state here that they nevertheless generally retain a *provisional character*, because in the study of the (productive) “economic consequences” of the tax: *a*) the method used in the study of “effects” has been followed. Notoriously this method generally *disregards the investigation* of the repercussions of the *employment of the revenues from tributes* carried out by the State and therefore disregards the effects on production of income of the use made of the fiscal revenue by people (to whom the State transfers it); *b*) furthermore forms of financial activity that (without necessarily causing collection of taxes) benefit the economic subjects in different ways and influence therefore the extent of social income that is produced in those periods.

¹⁵⁴ *Welfare economy*, in «New economists series», Utet.

¹⁵⁵ See E. d’Albergo – *Reddito e Imposte [Incomes and Levies]*, critical essay on productivism in financial activity, “Rivista Internazionale” [International Journal], Milan, 1932.

If it is recognised that the investigation conducted by making such first (a) general type of abstraction as imperfect, in the context of the study of the effects generally (alteration of the economic equilibrium) of the tax, so it is also the specific investigation, which aims to assess the consequences of the financial event on the production of income and of wealth, for the understanding of which, even if an approximation of it, it is necessary to follow the revenue of the tribute when it passes from the State to private individuals, and to take into account also the second type of abstraction (b) implicit in the studies known up to now.

Indeed, the purpose of the essay quoted in the last note and in the *Introduction* was to criticise the current formulation of the “conditions” necessary to identify productivity in the tributes or tax systems, as well as to research the conditions that must contribute or occur so that the tax (or rather the financial activity, in that context) can consequently determine an increase (trend or to be ascertained in a given period) of social income, disregarding other casual circumstances.

Therefore, with all the cautionary notes involved in an attempt at inductive investigation on the basis of our historic-sociological and indeed limited knowledge, it is necessary to approach the problem in a different way. Taking into account the effects of collection of taxes and expenditure of them at the same time, as well as the effects of financial events other than those that are purely fiscal, it is necessary to replace the current formulation of the productivistic principle with another that sounds more or less like this: “*the financial activity (or the taxation in itself necessary and instrumental to the production of revenue) becomes susceptible to the promotion of a progressive increase of production) if conditions favourable to entrepreneurs occur or are caused to occur*”.

Supposing that *the financial activity* should favour entrepreneurs (to achieve the purpose of maximum production of social income), in the sense indicated before, as a condition for financial productivity, implicitly they are considered as the *most effective instrument to achieve* the same purpose. The meaning of the term (entrepreneurs) overtakes the technical one commonly considered in manuals of political economy to indicate, in the Paretian sense of “speculators”, those people who *more promptly and more effectively* are able to take advantage of economic combinations (to which individuals or collective bodies correspond) and those who similarly, in the judgment of the State that favours them, are better able to carry out an instrumental activity with regard to the effect that the financial event, in a wide sense, intends to cause. It should not be necessary to recall that this effect is the premise of productivistic finance.

In recalling this treatise, I remember the repudiation of the term (productivistic) by Einaudi, who had however used it in the same sense to comment on Italian financial policy during the World War¹⁵⁶.

The terminological issue in itself would be irrelevant. I do not, however, see a reason to reject the term “productivistic”, which can also be abbreviated to “productive” to classify an approach in financial policy. Einaudi thought the word more appropriate to indicate the case in which taxes were engineered so as to “reduce to the minimum their pressure on producers to encourage growth of the maximum flow of income to be distributed among capitalists, proprietors, entrepreneurs and workers”.

It is, however, known that, from the terminology point of view, Einaudi’s responsibility in using the adjective “productivistic” is shared by other experts, and I don’t see, indeed, a strong reason to abandon the use of this very meaningful term in order to replace it with others with a more generic meaning such as tax and “optimum” or “economic” finance¹⁵⁷. In any case, Einaudi, who has many merits in terms of methodological clarifications, in particular with regard to his influential intervention in the recent disputes between Italian authors in this science, knows well that this is a matter of conventional questions.

¹⁵⁶ L. EINAUDI *La guerra e il sistema tributario italiano* [The war and the Italian tax system], p. 489 and following ones, Bari, 1927.

¹⁵⁷ The term is not unequivocal and therefore, as such, was criticised by U. RICCI (*A proposito del primo volume di una raccolta* [About the first volume of a collection], in the “Giornale degli Economisti” [Economist Journal], September–October 1942) and who, with the ethical qualification, seems to put forward judgment values that we have considered irrelevant to our science.

Considering, however, the essence of productivism, it would appear that Edgeworth wanted to delete this term because in his view: *a*) the State cannot commit, as a fundamental norm of its behaviour, to an objective such as that of minimising destruction or maximising production of wealth as this is an objective that the author believes to be irrelevant to the nature of the same State; *b*) the State acts for purposes that have nothing to do with production of wealth.

Einaudi's paradox becomes apparent only if we talk not of objectives of the State, but of the "citizens who act through the coercive State instrument". Indeed, he seems *to limit to the citizens as such* the concept of economic objectives or of increments of collective wealth or of objectives of a different nature. I will address here the sociological issue at the basis of this distinction. My only interest is to highlight a significant point of convergence of opinions with regard to productivism.

Indeed, given the objective – be it of the State or of men acting through its means – of the maximum (as a trend) production of social wealth, it is a matter of knowing if (among other things) the financial activity, as collection and expenditure of taxes, is "congruous" (in the sense of adhesion to a minimum price) with regard to the achievement of the objective, in other words, if the tax or the "fiscal system" is designed so as to favour it. Einaudi's expressions, here summed up, run along the lines of the approach I outlined in respect of the problem of productivism, in the essay I recalled earlier, in which I concisely and precisely logically linked: 1) the (direct or indirect) objective of the State of "encouraging" the maximum production of income or of social wealth; 2) the financial activity (in the sense of collection and expenditure of tributes) as concurrent causes to be examined in the effects, to understand if and when it is more or less adequate to the objective: this latter one becomes, rationally, an expected or wanted "effect" of specific real events of financial policy.

The reason put forward by Einaudi (to repudiate the "productivistic principle" because he meant a standard way to perform and not an abstract concept) was mainly based on the feared limitation of men's objectives (enrichment as material objective). This reason was reviewed by Ricci in the earlier quoted issue of the "Giornale degli Economisti" [Economist Journal]. He considered an economic good even the *spiritual good* that men want to get when they use State action to get *that spiritual good* because it is expensive to buy it on the market.

Furthermore Ricci differentiates among the modes of increasing national production (I would add, of material goods and services): can the State produce *direct services* (*immaterial* things) that immediately satisfy the desires and aspirations of individual users of public services? And can it produce *indirect services* that are instrumental to economic production?

What can be added now is that we can coherently talk about the productivistic principle, with the "dignity" of theoretical vision, in the logic of the vision of the public finance economy, as introduced in the *Introduzione* [Introduction] of this course.

We have seen how the financial factor, or the State as subject of the financial activity, has been considered an active factor or component for the purpose of production of income.

The instrumentality of the functionality of public finance in the context of distribution of taxes and distribution of expenses has been furthermore clarified in the logical Keynesian-type vision that I had already articulated in the sense of the modern expression of "economy of incomes" in 1932, according to what I recalled under letter *f*) of p. 125 and following ones of the *Introduction* to this course.

The logical sequence could be as follows: if the *State factor* is instrumental for economic activity with regard to financial activity, then coherently it must be directed, in the context of the distribution and deployment of tributes, so as not to hinder with the result of each combination tending to maximum productivity in terms of *quantum* of real goods.

If we want to retain the term (productivistic) "principle" in connection with the criterion to which financial activity must coherently correspond, it is certain that it has some theoretical content. This is so in the sense that, at least, once the hypothesis of the instrumentality of the State factor with regard to the events of production of wealth has been formulated, collection and expenditure *should not* logically contradict it.

In this sense the formulation of a productivistic principle or criterion coherent with the hypothesis of instrumentality of State activity with respect to combinations performed on the market in the field of production could be considered to be theory. If the (dependent) variable made up of the

national or collective income to be maximised, which I have systematically considered (in the study quoted in this paragraph), needs to be coordinated with the fiscal problem in the concept of current logical approach to “economy of incomes”, it is logical to conceive a mode of distributing taxes and apportioning expenditure that does not contradict the trend of this variable. In this sense a principle or criterion can be expressed that covers all financial activity, in other words, modes of collecting and spending tributes; this vision of mine, which considers incomes and expenditure in respect of the effects on overall income, has been defined as “integral” (Gangemi).

Of course, without the illusion of conciliating the hypothesis of lack of turmoil in the economic equilibrium (that the tax event necessarily modifies, as we will see further) of this vision, it is a necessary and sufficient condition, in the field of the logic of the instrumentality of the State factor with respect to the orientative fact of maximum collective income, that the modification of the economic equilibrium brings to the absolute maximum value of the dependent variable (income).

Unlike in the case of (Barone’s) “economic principle” and that of “neutrality”, essentially expressed by other authors, which we discussed in the previous paragraph, the productivistic principle *is not* expressed in the sense of *replacing* the others examined earlier, as the ultimate “principle” that could explain all phenomena in the context of the *modes* of distribution of tributes.

In other words, by talking or writing in terms of “productivistic” objectives, we do not claim to undermine such principles on subjective bases that have been discussed for a long time and that, as has been demonstrated, can carry a relevant weight in respect of the solution of the problem, as they do in the logical context for the explanation of the events. However, these are complex issues, so these principles can be *coordinated* and logically conceived as co-existing.

This was what, for example, Edgeworth had realised¹⁵⁸ when he suggested caution with regard to the ultimate effects of the application of the principle of minimum collective sacrifice. He was concerned, precisely, with the obvious criticisms that could be addressed (levelling of incomes) not only to the principle of minimum sacrifice but also to those of the equal and proportional sacrifice, of the development of wealth and the accumulation of the same.

It is true that he talks about the limitations of principles but it is the intervention of other points of view on the single issue that operates in his mind as a theoretician: this tells us that the *combination of several principles*, in further and subsequent approximations to the real phenomenon, can contribute to helping us understand other aspects of the wide and complex domain of events.

It is not therefore possible to replace other principles with the contribution of new schemes. Generally, however, all simultaneously and without necessary contradiction, operating in the field of subjective entities (utilities) and in that of objective quantities (the amount of incomes and assets) bring waves of understanding, even if they limit each other’s degree of applicability to facts because of having to conciliate multiple principles.

IV.

THE SO-CALLED CRITERION OF EXPEDIENCY

Finally, I do not believe it is possible, as I have observed in previous editions, to assign the dignity of theoretical principle to the factor called expediency or convenience. For example, also in the 1948 edition of his essay¹⁵⁹ Prof. Alfred G. Buehler, of the American Vermont University, after presenting the theoretical notes in which the doctrine has attempted to explain the distribution of the cost of indivisible public services, places the principle of “expediency” alongside or in place of traditional principles.

This “principle” would explain many of the fiscal institutions or modes of distribution of the fiscal burden because: 1) without it, many taxes would have no rational foundation; 2) the legislator, under the pressure of conflicting interests, adopts compromises that reflect the route of least

¹⁵⁸ This was Fasiani’s exact wording in the essay: *Schemi teorici ed “exponibilia” finanziari [Theoretical systems and “known financial propositions”, Riforma sociale] [Social reform], 1932).*

¹⁵⁹ Titled: *Public Finance*, McGraw-Hill Book, first edition, 1936.

resistance, that is to say, a policy of “expediency”, “convenience” or contingent opportunity; 3) the evolution of fiscal systems has more a chronological than a logical nature; that is to say, it is the result of political approaches, traditions, chances, theories of justice, fiscal concerns and other contingent circumstances; 4) the expediency “principle” has a greater influence on fiscal events than the theories of contributive capacity or of *benefits*, and represents the best guide in the field of imposition, when there are no other regulatory criteria.

It would be possible to dismiss such propositions, some of which are *derivations* in the Paretian sense, and consider them as manifestations of personal ideals, if the obvious influence on Buehler’s thought of works he quoted in the bibliography was disregarded. The author thought he was promoting to the status of “principle” the synthesis of the circumstances that I have mentioned for some time and that feature in paragraph VII of Chapter III and that, *effectively*, determine in total or in part fiscal reforms. He did so after reading in I. A. Hobson: 1) that the fiscal system evolved in an environment of “fumbling empiricism”; 2) that it is the result of expediency and contingent opportunity and not of principles of financial theory clearly understood and adequately applied¹⁶⁰.

Similarly, Buehler was affected by T. S. Adams’s scepticism, moreover in part contradictory. As president of the American Economic Association, Adams stated in a debate, among other things, that: 1) the being of taxation is permitted by the conflict of classes. In his view this truth refers not only to the formation of positive fiscal laws but also to the economists’ theory on the subject of imposition; 2) the branch of economy that deals with fiscal problems can never be purely or mainly a science (the author contradicts himself by suggesting the probability that what is true about imposition is true of other branches of economic science in which the uniformities searched for by the economist depend essentially on the conscious and planned action of social groups)¹⁶¹; 3) in the fiscal field, the truth researched by unbiased economists exercises a real influence on fiscal policy. The action of such scientific truth is largely critical, negative and indirect but it is also intense and powerful; however it represents only a factor of the conflict known as imposition. To think that such a factor prevails in practice is a sin of “intellectual arrogance”.

I will not continue with the quotation of other “axioms” expressed by Adams; Buehler clearly felt their suggestive force in reaching the claimed expression of a *new principle*.

Furthermore, this is another *empty box*, that is to say, a concept devoid of any rational or in any case scientific content. The author seems to invoke the combination of sociological or politico-historical elements that, in practice, the man in government takes necessarily into account in any case. This, however, is not the pertinence of science: science can observe that the real financial phenomenon is also dominated by political factors and, generally speaking, that it is complex or synthetic, without claiming that it gives genesis to *new theoretical principles*.

¹⁶⁰ *Taxation in the New State*, First part, Chapter I.

⁽¹⁶¹⁾ However, Adams also admits: the work of economists mobilises forces that modify the action in question. This and the preceding concepts can be found in *ideals and idealism in taxation*, “American Economic Review”, 1928.

CHAPTER VI

QUALITATIVE DIFFERENTIATION OF TAXABLE INCOMES

I.

REASONS THAT DICTATE THAT THE STUDY OF DIFFERENTIATION OF TAXABLE INCOMES COMES BEFORE THE PURGE OF THE OBJECT OF THE IMPOSITION

In coming at this point to the chapter relating to the qualitative differentiation of incomes, we continue to abide by the logical vision of the subject in this course. That is to say, the *mode* to distribute tributes precedes the analysis of their effects, in the various hypotheses of economic organisation or market conditions. Because the discrimination or differentiation of tax rates or taxable incomes means, as we will see, perfecting the criteria of equality that dominate in the field of imposition, it is necessary to be rationally aware of the modes of implementing this equality, such as they have been empirically enshrined in the legislation of many States, for example, and not always or not entirely interpreted by theory when academics have been concerned with the so-called “qualitative” differentiation of incomes.

a) Indeed, the long-problematic presentation, having as its object the logic of progressive imposition, has dealt with, as has been indicated warned, the *quantitative* differentiation of incomes, in particular as disposable incomes (or wealth) for the consumption or enjoyment by physical persons, in whose hands they flow as incomes (or assets).

Furthermore, in light of educational experience it is not effective to distance, in the presentation, a problem of quantitative differentiation from a process of *qualitative* differentiation. This is so not only because this latter is another *mode* of implementing the equality of the imposition, but also because, as we will see, strictly speaking it is necessary to return to the *subjective* criterion of overall and *effective* availability of incomes (as well as their *formal* and *monetary* expression) in the hands of physical persons including in the field of qualitative differentiation. This is primarily limited to the sector of real taxes in the current treatises of these problems; real taxes to which, furthermore, the legislation of all countries has conferred aspects that are characteristic of personal tributes, as if to reveal the intuition of the pertinence of the matter that I demonstrate here, to the field of the personal and general imposition.

b) The same warning of methodology that regards the connections between the various parts of the matter in hand needs to be taken into account, considering all that has been said regarding the concept or principle of the contributive capacity. I have tried to confer meaning to this otherwise vague concept or principle from a determined point of view, making the capacity of pay taxes a function of the differential use of the State action, as a factor of production of income (with public expenditure and other forms of financial activity).

Now, in the literature that has dealt, to the greatest extent, with the problem of the qualitative differentiation of incomes there has been discussion about contributive capacity or *ability to pay*, always in the search for empirical criteria or logical principles of equality of taxation. At a similar level of monetary taxable income, a *lesser* contributive capacity has been noted in incomes relatively temporary, discontinuous and uncertain compared to the capacity revealed by the perception and the availability of permanent, continuous and certain or relatively less uncertain (or risky) incomes¹⁶².

As a logical sequence, it would not take long for the differentiation or discrimination of incomes (performed, as will be seen, through deductions of quotes from incomes as not available for taxation and through formal inequality of proportional fiscal collections) to be taken into account, as it was indeed necessary to explain why incomes quantitatively and completely equal in the *monetary* expression do present, as many can observe, unequal contributive capacity, so justifying the already

¹⁶² From a technical and administrative point of view, verifiable with a different approximation to reality or with a different degree of evasion.

mentioned deductions of taxable incomes for some *forms* of them (nature or source) or the different corresponding tax rates.

What can be said of the imposition through the means of a single hypothetical tribute (real or personal) with regards to differentiation or of formal and differential treatment of taxable incomes, can also be said of the entire fiscal system or of a large sector of it (especially in terms of direct imposition). Indeed, it is necessary to explain the logic of the system, from the point of view of the *effective* equality of the tributary burden, in spite of, but also in particular because of it, by using the empirical criterion of *coexistence* of different tributes on different types of incomes and on assets, for the purpose of targeting relatively more closely incomes that have the characteristics of perpetuity or greater certainty, as legislators and academics normally suggest.

c) The logical links between the problem of qualitative differentiation of taxable incomes, as revenues, and those recalled in the previous letters *a*) and *b*) are theoretically immediate and necessarily suggested by a logical priority over those that connect the problems mentioned before (in *a*) and *b*)) and the purging of incomes and assets in terms of their shifting, precisely, into taxable incomes that it is preferred, in these pages, to postpone the logical treatment of the system of shifting to the net value of the object of the imposition represented by wealth, in its more general meaning.

In fact, in saying that qualitative differentiation is a phenomenon *completely different* from that of purging (as De Viti De Marco defines it) because the first consists “of some further deductions that the law grants to specific categories of incomes in addition to the quotes deducted for their shifting into net value”; or in stating that the deductions as differentiation presume already purged incomes so that, *after* having translated (incomes) into net values the law concedes *further* deductions; or in saying that the *different* percentages are applied *after* incomes have been translated into net values, De Viti helps, in these expressions that I have highlighted, the understanding of a certain logical independence of problems and a mainly or entirely chronological sequence of phenomena.

In this way no greater discretion is needed in assigning to the study of the differentiation a greater rational connection with theoretical problems of equality of the imposition, examined in detail in the previous chapters, which might be more in line with that of equality implemented with the differentiation, than with the study of purging of incomes to make them taxable because they are net (produced and perceived or disposable). It is, however, a lesser discretion than it might appear to those who put the illustration of the process of purging before that of the differentiation, without adequate rational explanation.

In any case, as it is necessary, in the context of the illustration of this latter process, to have a definition of taxable amount, in particular with reference to income, for the purpose not only of producing a coherent concept with these financial analyses, but also for the solution of the problem of the rationality of the same differentiation, we will anticipate some notions of the concept of net income, particularly as a result of the purging system such as it is considered in financial theory.

II.

POLITICAL AND SOCIOLOGICAL EXPLANATIONS OF QUALITATIVE DIFFERENTIATION

After these warnings, which introduce us to the treatment of the problem of qualitative differentiation from the point of view of economic theory, it would be appropriate to recall some mainly extra-economic explanations of the differentiation of taxable revenues, in particular as incomes. This is necessary from an historical point of view as well as in order to differentiate what is relevant to the science from what is more relevant to the field of ethics, politics and sociology, as some people believe.

We can state that attempts to explain the phenomenon of qualitative differentiation such as those that follow do not belong to the field of public finance economy.

a) One is expressed in the comparison of incomes that are differentiated as *earned* or *unearned* to indicate that they are socially or morally “deserved” or otherwise, in the meaning that each time has been conferred to the terms indicated here.

For example, the incomes are not earned or deserved that have been obtained “without working”, if they have come through heredity or in other words an income from such a source, whereby the heir makes the most of using someone else’s work, or when it does not come from one’s own savings or work.

Others express the same concept by stating that earned incomes imply a cost sacrifice in their production, which is something missing in the case where the source of the income is an inheritance.

b) Some authors believe that non-earned income is that which exceeds what is necessary to remunerate activities that maintain in being existing productive capabilities: such is the case of an interest rate that exceeds the minimum for the use of capital plus an amount for the risk involved.

c) The basis of differentiation for fiscal purposes is recognised in the Marxist theory that was dominant at the time that *income tax* uniformity was being criticised in England, in spite of the different nature and quality of incomes.

In this case the “social” interpretation of Marx’s ideas stated that the “profit” of the capitalist derived from the exploitation of the “worker”, who was the only creator of the income. Only a salary would be deserved (earned) income as it derives from the worth of work, while profit is undeserved (unearned) or stolen from “workers”.

When the production factor (work) is missing so is its product. Thus it would appear that the entire product derives from the missing factor: capital would be useless, in spite of the lesson in the parable of Agrippa, if work did not have the merit of making capital productive. On the other hand, it is clear that what is a relationship of interdependence is therefore transformed into one of cause and effect. Furthermore, this disregards the fact, with regard to worth, that capital in all its forms is the result of *previous* work that has produced income, a part of which has been saved, in other words, taken away from consumption to become a form of instrumental asset, to be combined with new work.

[In truth Marx’s view, summed up in imperfect synthesis and only to suggest meaning, was quite different. He started from the ideas of Ricardo, who identified the “cause of the value” of products in the cost of production. Reducing this theory to that of value-work, Marx was expressing the theory of *surplus value*; that is to say, he maintained that both the profit of the capitalist-entrepreneur as well as the income of the landowner derive from the difference between the total value of the product measured in terms of work and the portion of it used to pay the workforce. These differences, therefore, according to this concept, resulted in being undeserved or unearned, from the point of view that is of interest here, in this quick list of points of view, that are *irrelevant* to the theory that we are considering in these pages, and that have been indicated for cultural purposes or for the history of ideas gravitating around the economic problem of the qualitative differentiation of the subject of the imposition.]

d) A purely political explanation of the differentiation of incomes, with an approach similar to that which the illustrious author had with regard to the progressivity of imposition, was put forward by De Viti De Marco who concluded his argument by stating that the diversification of work incomes is an institution in itself, which finds its immediate and sufficient explanation in the political preponderance that industrial, professional and working classes have and exploit to achieve fiscal exemptions. As a consequence of subtracting from the taxable amount and reducing tax taxes, tax rates on those incomes that do not benefit from deductions must be increased. “Therefore the phenomenon of differentiation must necessarily be linked to phenomena of shifting. And when differentiation is applied to smaller incomes, then the tax becomes progressive. In fact the policy of *special benefits* in favour of lower and working classes represents a great proportion of this differentiation” (pp. 207 and 266 of *Principii* [Principles]). This vision, which can be relevant outside the domain of financial economy, is also referred to as a comparison of fields of study of the same event that shapes fiscal laws.

III.

DIFFERENTIATION EXAMINED

On the other hand, their differentiation, as incomes, in *founded* and *unfounded* retains a meaning that is contextualised in the economic explanation of the process of differentiation of taxable incomes.

In a distinction based on the *source* of the incomes, the first expression refers to incomes that derive from estate and moveable capital assets considered in themselves, in other words combined with other factors which are relatively less durable (work in the wider meaning of the term or in its various forms).

The second expression (*unfounded*) refers to incomes derived from the pure work of the physical person (in the various typical applications and specialisations, actually noted).

These expressions lead us to the field of interest of public finance economy. Indeed, incomes are qualitatively differentiated through this comparison of terms, as a function of factors recorded above in the definition of the phenomenon; that is to say, as a function of *duration*, *probability* or *degrees of uncertainty* (risk, continuity) referred to production or more coherently to the availability of incomes of the subjects of the economic activity, considered as taxpayers.

We will pause at these synthetically indicated prerequisites of the process of differentiation to integrate and complete them and, in short, to interpret them, for the purpose of giving a rational explanation of the phenomenon which normally consists of a relatively different taxation of more or less founded incomes.

This limitation of the rational content of the study to only the economic problem was intended to remain compliant with the vision that shapes the *Introduction* to this course of lessons, in the sense that it is irrelevant to the type of State that frames the problem of the equality of the imposition, and that its bases and rational developments are studied from the point of view of qualitative differentiation.

This also excludes the need for this treatise of pure economic theory, raised from the solution to a problem about the *mode* to measure the imposition on incomes (here examined as direct), to necessarily refer to the principle that shapes the “cooperative State”, as Fasiani would have it. This rational and objective demonstration applies to all types of abstract States and to all historical periods in which the problem of the qualitative differentiation of incomes is framed and that, in the context of economic logic, cannot but be framed in the terms here reported (for the history of theories) and in particular in the terms I believe should be used to frame this problem, as I will demonstrate.

If we reason on the basis of non-economic elements and criteria, whatever the type of State whose governing class has adopted them, and if for example the argumentations were to be of the types that have claimed to explain the differentiation according to the sense indicated in letters *a)*, *b)*, *c)* and *d)* of para. II of this chapter, it would be necessary to state that we are without the financial science that has been considered in respect of the aspect that, up to now, we have believed to give rational content to public finance economy.

IV.

THE TWO THEORETICAL APPROACHES OF THE PROBLEM: A) ONE OF
 OBJECTIVE OR RICARDIAN TYPE;
 B) THE OTHER, APPROPRIATE AND RATIONAL, OF MARGINALISTIC OR
 SUBJECTIVE TYPE, IN THE MEANING THAT WILL BE SPECIFIED

I will start by saying that my vision, stated mainly in the 1944 edition of this course of lessons, is subjective and so expressed since the presentation of the matter in the sense that, from the point of view of the *availability for consumption*, *not* all incomes are the same, if the source they are derived from is considered.

However, a more explicit position, which I introduce with the purpose of directing generally the reader or student, is contained in the following proposition that followed the close examination of various aspects of the qualitative differentiation of incomes according to their duration and the probability of their being produced over time: "These and other analogous argumentations already presented in favour of differentiation should rationally presume the *synthesis* of the economic conditions of taxpayers (subjects) such as it is expressed by the *overall* incomes differentiated according to their source"; that is to say, the differentiation should more logically take place in the context of *personal* imposition rather than in the context of real taxes, which do not take into account the overall economic condition of the physical person or the family unit (subjective concept).

I have been supported in this vision by the approval of Borgatta (who is well aware of the attempts, in a subjective context, to give an explanation of the phenomenon of the differentiation of taxable incomes or tax rates empirically found in legislation concerning fiscal systems and individual complex taxes). In reviewing the 1944 edition of these lessons, with regard to the logic of qualitative differentiation, probably keeping in mind the conclusion I reported above in his critical presentation, he commented: "It is not clear how, with the rise of personal taxes, it has not been felt that the logical context to evaluate the need or otherwise to apportion a part of the actual income to future needs is not the real but the overall personal tax: only with the knowledge of the overall income and of all sources available to a taxpayer, it is possible to evaluate his need to save a part of his current income". (See review of the 1944 edition of these lessons, recalled in the preface of the current course).

This paraphrase of my thinking, in the sense of the reconfirmation of the rationality in the presentation to third parties by Borgatta, as one of the "elements that stimulate the reader to new thinking and thoughts in the theories presented", elements that he had the kindness to find in my lessons, is useful here in the comparison of the points of view in the letters *A*) and *B*) of this paragraph. Indeed, to understand this, it is necessary to recall previous presentations, that is to say, the vision I defined as being of a Ricardian type, to remember the words of Fubini, who demonstrated not to have understood Stuart Mill's thought on this subject.

If I insist on making continuous reference to my own thinking at this regard, it is not because of the priority of this *intuition* that, as we will see, could be found in other authors, such as Giuseppe Ricca Salerno and Graziani, but because I believe that: 1) the treatise should follow the vision in the chapter regarding quantitative differentiation, in other words, according to the premises and approach I set out regarding the problem of the progressive imposition; 2) the *demonstration* is yet to be given according to the most up-to-date *dynamic* theory, that is to say, by introducing the time factor into the hedonistic reasoning: this demonstration is attempted in these lessons.

In other words, with regard to the aspect in 1), over and above the difficulty of a verification of subjective evaluations or of a measurement of the marginal utility of the subjects' mode of reacting hedonistically when faced with the imposition that measures incomes of different natures from the *point of view* of the idea formed by the State governing class, it is necessary also to resolve rationally the problem of qualitative differentiation that, with good reason, I have logically placed alongside that of quantitative differentiation (progressive imposition).

I will come back to this later. For the moment I will make reference to the evolution of points of view from which the problem has been studied.

A) Traditional English experts and also our own academics turned their attention to the explanation of the empirical and incidental event represented by the introduction of *income tax* since 1842. Prior to this date taxation had mainly the character of an extraordinary tribute, which had contributed to the expenditure of the Napoleonic wars.

This tribute represented a real category of the type of tax that, according to some, is called *general* and is theoretically characterised by the uniformity of taxation, in the sense that it should, as such, give rise to a uniqueness of treatment, with the absence of discriminations, whatever the source of the various quotes or parts of income or the nature of them, in the sense indicated above, comparing "founded" and "unfounded" incomes.

This characteristic of the uniformity of general taxation, with proportional rates, deserved criticism because the same imposition was applied to non-homogeneous incomes, as parts of the overall income represented by various categories of incomes deriving from estate investments or

moveable employments, from industry, professions, annuities and incomes from pure dependent work (salaries).

By considering the various incomes as heterogeneous *in themselves*, the focus passed to the differential character of the different *durations*: permanent and temporary incomes should not be taxed equally, as this appears to be a clear “injustice”. This *objective* consideration or of itself of single incomes leads to the comparison of the same terms of respective capital value, that is to say, as a function of the different duration. For example, according to Giacomo Mill, what was expressed in the following terms appeared to be “justice”: “if an income represents a capital corresponding to half the years of income of another, it should bear one half more tax; if it represents a capital corresponding to a third more years than the income of another, it should bear one third more tax, and so on” (p. 235 of the Italian edition of 1831 of the *Manuale di economia politica [Manual of political economy]*).

Parliamentary and technical staff contributed to the debate on this subject; among these there were actuaries, always considering objectively in themselves the various types of incomes, differentiated by different *durations*. It is clear that from this point of view a temporary income was less valuable, in terms of capital value, than a permanent income. Given an interest rate, for example, of 5%, a permanent income of five units is worth 100 units: in other words it is equivalent to a capital of 100 units; if it lasts for ten years its capitalised value is 38 units.

From this realisation, in itself faultless, with a logical leap actuaries reach the conclusion that: *therefore*, two incomes of five units in perpetuity and of five units for ten years must be taxed in a non-uniform manner if the intention is to have “justice” expressed in terms of equal taxation. Essentially a higher tax must correspond to perpetual income.

Thinking in these terms attracted the criticism of J. S. Mill who, in brief, observed that if an income is capitalised in function of its duration, then its corresponding income must also be capitalised using the same criterion. With a 10% flat rate applied to five units in perpetuity, capitalising 0.50 leads to a figure of 10; at the same time, capitalising 0.50 for 10 years gives a figure of approximately 3.80, so it is not possible to suggest that there is no equal treatment, in terms of reduction of the capital value due to taxation, given the equal incidence of the uniform taxation. Indeed, as a negative element, it is necessary to capitalise the tax that, even at a *uniform* rate, affects the two incomes hypothesised for *different* durations. This can be read in the text, on p. 980 and on the following pages, of the *Principii [Principles]*¹⁶³.

This criticism, based on objective terms, has remained unchallenged in Ricardian-type thinking, in which subjective factors are not considered. [Of course, as we are dealing with capital values that find their genesis in the market, even if this imposition were appropriate it would not be able to explain the equal taxation of different incomes if the 10 units were presumed to be, for example, the income from dependent work (salary) which is not subject to capitalisation as the human person is not the object of exchange in civil society.]

¹⁶³ “The current tax treats all *types* of income in the same way, taking seven pence for each lira from the man whose income *dies* with him, as from the landowner who can *transfer* his entire wealth to his heirs. This is a clear injustice: at least it does not mathematically violate the rule that taxes should be in proportion to means. When it is said that a temporary income should be taxed less than a permanent one, the response is obvious, that is to say that in fact it is taxed less; this is so because an income that lasts for only ten years pays taxes for only ten years, while the one that lasts in perpetuity will always pay taxes. On this finance reformers are very mistaken. They deny that incomes should be taxed not in proportion to their annual amount but on their capitalised value: that, for example, if the value of a perpetual annuity of 100 units from 3,000 units, and an income of the same amount for the duration of a lifetime could not be sold for more than 1,500 units, the perpetual income should pay twice as much; and if one of these pays 10 units per year, the other should pay only five. However, there is a great flaw in this argument because it evaluates incomes in one way and payments in another: it capitalises incomes but not payments. An income of the value of 3,000 units should be taxed twice as much, they say, than one of 1,500 units, and there should be no discussion about this; but we forget that an income of the value of 3,000 pays 10 units per year, while a non permanent income pays the same 10 units only during the lifetime of its owner. For this reason an income that is half of another pays half the tax; and if this portion should be reduced from 10 to five, it would pay not half but only a quarter of that asked of a perpetual income.”

However, the criticism from Mill about the objective criteria of actuaries and of those who think like them cannot exhaustively address the question, which had not been rationally set. To do so it would be necessary to abandon the objective vision as inappropriate to explain the phenomenon that is not, normally or only, represented by equal taxation or by uniform taxes and rates, but that has empirically presented in the historical cases: I) differentiated taxation of equal monetary amounts of income deriving from different sources; II) taxation with uniform rate, but charged to taxable incomes obtained by deducting from equal monetary amounts of income from different sources deduction portions of nominal value, in function of the different source or nature of incomes more or less founded, in the sense exposed above.

The same J. S. Mill, who had *denied* the real inequality of taxation of incomes of different duration, subject to equal or uniform formal taxation, would not be able to explain the phenomenon of the different (and yet really equal) taxation (differential tax rates or deductions from similar monetary amounts of different incomes) other than by abandoning the logical position of Ricardian type and introducing criteria of *subjective* nature.

Unlike what Fubini observes with regard to this (*Contributo alla determinazione del concetto di imposta generale [Contribution to the determination of general taxation]*, in the “Economist Journal”, May 1932), it is not a matter of “*one of the tortuous routes that Mill sometimes used, to insert the subjective extra-Ricardian elements in his own system, strictly based on a Ricardian structure*”, but of the logical and necessary abandonment of a route for another, as the first was inadequate for the explanation of the phenomenon of the qualitative differentiation of incomes, in the context of taxation.

B) A step towards this *subjective* vision of the problem was taken by MacCulloch. He had abandoned what in political economy manuals is referred to as the concept of objective income, referred or linked to a determined form of capital from which it emanates (land, buildings, moveable capital, etc.), in favour of the subjective concept of income, referring in other words to the subject that performs the economic operations through which it is formed and of which he feels the benefit. In this way we have the income of a landowner, an industrialist, a professional, a salaried person, and so on, perceived and to be enjoyable, or enjoyed.

Indeed MacCulloch had already stated that “to proceed according to justice, we should take away from the owners of temporary annuities, professionals, etc., the portions of the temporary annuities corresponding to an insurance on their lives, for sums equivalent to the actual value of their incomes, and tax the rest” (on p. 88 of the *Trattato sui principi e sui pratici effetti delle imposte [Treatise on the principles and on the practical effects of taxes]*, etc., Italian edition, Economists Library).

The quantitative suggestion of this classic academic is not of interest: however the introduction of the subjective principle is, with reference in his thinking to the income of the person or to the *subject that perceives it*, even if roughly made.

Passing from a Ricardian type of vision to that of a marginalistic type, even though in the phase of intuition rather than of development of this current economic analysis, is much more apparent in J. S. Mill when the passage quoted from the *Principii [Principles]* is interpreted in respect of the following propositions, drawn from the most representative ones, that I coordinate to simplify the text of the reasoning:

a) “To the shame of nominal equality of income, subject *A* (intended as subject), enjoying an income of 1,000 units per annum, cannot easily pay 100, as (subject) *B*, who derives the same annual income from an inheritance; as *A* has more demands on his income than *B*, that is to say, of having to provide with his savings for his children, to which, in the case of salaries and earnings from a profession, the need to provide for his last years should normally be added; on the other hand *B* can spend all his income without suffering in his old age and still be being able to transmit his wealth to others after his death.”

b) “For this reason the principle of equality in taxation, interpreted only in his right sense, the equality of sacrifices, requires that those who do not have the means to provide for their old age other than through their own savings, are exempted from tax in so doing.”

In this way it is possible to explain concepts that, previously used by him with the terms “feelings and human necessities”, according to the mistaken current literal interpretation, relegated from the field of science factors on the basis of which Mill reasoned, to compare, as can be seen, the objective (or *mathematical*) vision with the hedonistic or subjective one of marginalistic type, as it is called today¹⁶⁴.

Therefore Mill proposes “expedients” to implement differentiation as suggestions “to be weighed by those who can judge competently on such difficulties”. “If no plan can be applied so that exemption can be restricted to that part of income that is now saved, it still remains a rough expedient of different reasons for taxation”. With this, J. S. Mill introduces the subjective element, enabling it to explain (with the diversity of the *sacrifices* suffered by those who have to plan for current and future needs, with means that are not equally available) the difference in tax rates used both in fiscal systems and in individual taxes for empirical taxation of incomes of different natures or founded differently. For completeness of vision, he also makes the case of net profits perceived by business people, suggesting an intermediate reason (rate) among those that should be adapted to interests from capital and to work salaries, as extreme cases of simplification. From this follow other complications of subjective situations that are difficult to regulate in law, but always on the basis of the principle of equality in taxation, according to which “each one should be taxed, not in proportion to what he has but of what he can spend” (*i.e.* the disposable income after having taken care of future needs).

Some might see this latter concept as an echo of the problem or theory of the so-called double taxation of savings. I will not discuss this here but will dedicate Chapter VII to this unfounded case of inequality of taxation, which has engaged many supporters of this theory to no avail.

Here I will limit myself to saying that, as it is not in my view absolutely logically necessary to go back to this “theory”, as Fasiani suggested, before changing his mind on this problem of the double taxation of savings (that is to say, in the essay: *Di un elementare problema di tempo [About an elementary time problem], op.cit.*), Mill responded with the arguments that on their own justify the empirical differentiation of the general tax and explain the logical bases of the procedure that implements the equality of the sacrifices with the differentiation of tax rates.

I say that there is no logical need to recall this theory, on the basis of another demonstration. I am referring, for example, to the fact that L. Einaudi, who stubbornly insisted on wanting to see the double taxation of saved income (in the system of taxation of produced income, as I will explain later), in the wake of Mill and Fisher, and discussed later the diversification of the tax with respect to incomes from capital, from work and mixed incomes (I quote from the 1940 edition of *Principii di Scienza delle finanze [Principles of the science of finance]*, pp. 177-188) on the basis of the origins and nature of incomes, *did not use at all, in forming this logical explanation, the famous theory*. He deals with the possibility of the taxpayer consuming his income in total or in part; of the different availability of incomes with respect to payment of the tax and the different degree of “concern” of those people who receive incomes of various kinds, and a different degree of need to save, as an action that needs to be presumed by the legislator as a function, precisely, of the different availability of incomes, as founded more or less on capitals or on a combination of capital and work.

Furthermore Einaudi refers to the illustration of the Italian legislative empiricism, both regarding the individual law (tax on moveable wealth) and the fiscal system, integrated, as we will see, by the ordinary tax on assets coexisting with the personal, progressive imposition, that discriminates, but only in quantitative terms, between the overall net incomes. However, in this explanation of the real differentiation, there is no sign of returning to Mill’s demonstration, carried out

¹⁶⁴ It appears to be significant that J. S. Mill, on occasions of the *People's edition* (1865) of *Principii [Principles]*, modified the expression he had previously used, highlighting the hedonistic and subjective aspect of his vision. Indeed, while the 1849 (II) edition, which was used for the translation in the Economists Library, Series I, Volume II, p. 981 (1851) reads: “The claim does not rest on grounds of arithmetic, but of *human feelings and necessities*”), in the subsequent popular edition indicated above, it reads instead: “... but of human wants and feelings”.

In the Italian translation, Mill’s thought, in the indicated sense, is not rendered with due care by the words: “The pretence will not be given on the grounds of arithmetic, but on the grounds of feelings and human needs”.

mainly by the same Einaudi, of the presumed double taxation of savings, in the traditional meaning that will be explained later.

Here it is sufficient to know that even this presumed demonstration of Ricardian type, that is to say, one carried out on an *objective* basis, gives way to the explanation of *subjective* elements of the qualitative differentiation of incomes, as non-necessary and insufficient.

These elements are necessary and sufficient to provide a hedonistic base to the scientific treatise of the problem of the equality of imposition, also through a process of differentiation of tax rates or deductions of quotes (presumed savings) of incomes judged to be variously available, because variously “founded”. The simultaneous consideration of present and future needs is suggested, specific to the familiar type, that the legislator or the governing class believes to be carried out by the average human behaviour, as utilitarian judgment, by the taxpayers subject to the mainly direct taxes that engage us here as hypothesis.

Observing that in this way the differentiation of incomes with regard to the physical persons who receive them and enjoy them and in addition not with regard to those subjects who are not physical persons¹⁶⁵, is not important when faced with facts and in a theoretical context, both: I) because everyone can consider the inconvenience for the legislator (for example the Italian, French and English ones) of the various “abatements” and deductions, in the context of largely real taxes, with the infiltration of the subjective element for a logical necessity that leads to the degeneration of the positive juridical institutions, as it delays the qualitative differentiation of the personal State imposition; II) and because a rational solution can be found, more or less, for example in the synthetic Italian “family” tax, that takes into account the mainly subjective element of relief, placing it, among other things, in relation to the *set* of incomes, and with the *nature* of incomes, depending on whether they are patrimonial, industrial or professional.

It is sufficient to have this reference to events in order to give realistic foundation (even though it is necessary in a hypothetical context to at least avoid “idle” science, as said in the *Introduction*) or meaning not only to the inventiveness of the logical bases of the standard way to do things that, as I said to start with, would suggest a personal imposition in respect of the differentiation of incomes that is both quantitative and qualitative at the same time, but also to the inventiveness of the *subjective* vision on which I have insisted, as appropriate in order to give a hedonistic explanation of the differential treatment applying to incomes of diverse natures, in the hands of physical persons as beneficiaries in the widest sense.

A quick *intuition* of this order of reasoning, as I have just mentioned, is to be found in the works of G. Ricca Salerno and Graziani, an intuition that is here overtaken in the light of appropriate demonstrations on hedonistic bases. I want to quote this short text of Graziani, who had the thought of Ricca Salerno in mind, at this instance (*Istituzioni [Institutions]*, U.T.E.T., 1929, pp. 290-91):

“Whoever owns a perpetual income has earnings capable of continuous repetition; with that he can therefore provide for needs that are periodically renewed.

“On the other hand, whoever receives a temporary income has to face needs that are renewed but he has earnings that at a certain point will stop recurring; it is therefore necessary for him to save for it in part, transform it into capital to procure a continuous income, to match to his needs. At the same level of income the final utility of perpetual income is less than the final utility of temporary income, as its owner can apply to the satisfaction of luxury needs the part of the income that the owner of a temporary income reserves for more urgent future needs. Therefore a differential participation in public burdens is necessary to implement the equality of the subjective value of the wealth ceded. The principle of diversification of incomes is not sanctioned to avoid tributary duplication nor for a general principle of exemption of imposition on savings, but because incomes that are quantitatively equal but different in duration, all other circumstances being equal, imply a different ultimate degree of utility, so that a different rate of imposition ensures the equality of the subjective value of the wealth ceded to the State. These considerations certainly apply to the general tributary system, or at least to a general tax on income, not where this or that tribute is applied to one or other type of either product or income, as it is clear that the owner of a special temporary income

¹⁶⁵ For them the criteria of *objective* capitalisation of incomes with different duration and probability apply.

may have other incomes of different natures, and our observations regard the overall general economic condition of the individual.

So Fasiani contrasted Graziani's thought, which he certainly had in mind, with this artificial devaluation of the same, usually confusing, as many other authors had done, the measurability of the utility entity with the reasoning about this entity on the basis of *the idea of it that the governing class has*, which resolves in such a way the problems that the theoreticians explain. We have covered this abundantly when dealing with the progressive tax. In the meantime, however, the criticism aimed at Graziani in the following terms is out of place: "Only those who apply the principle of the decrease of utility of income to financial problems, without being too concerned about the possibility of comparing the feelings of different subjects, state that" ... which I have said above about Graziani.

It is not necessary, as I have nevertheless suggested, to go back to the chapter on the progressive imposition to refute this erroneous interpretative position on financial mass phenomena. However, remaining in the context of Fasiani's monograph, covering the qualitative differentiation of incomes¹⁶⁶, we find that he formulates the figure of the "income of the unmarried man", which cannot be based on the judgment regarding hedonistic evaluations that are normally formed by the governing class to resolve the problem of the relative differentiation. Therefore this judgment cannot be based on the idea that this class forms of the attitudes of the typical subjects it hypothesises with regard to their evaluations of present and future goods; therefore it is in relation to the psychology of the subject that the "third" (State) is considered to be "normal or abnormal" with respect to an "economic period" considered for the consumption of the income, over time (phenomenon examined by Fasiani).

Moreover, it is not enough to carefully avoid using the logical category of "utility" that the subjects link to present and future assets, consumable in a varying ratio as a function of the availability of temporary or perpetual incomes when this category is decisive and inevitably implicit in the evaluation of the same typical or average or normal private subjects that emerge from the mass observed by the subject of public finance (State), of which the academic tries to explain the behaviour in the differentiation of incomes in a qualitative sense.

It would have been more coherent, also with regard to this problem (as it happened in the case of the progressive imposition, against the prejudicial presumption of the type of criticism aimed at Graziani), to assume the logical position that relentlessly and against the theory transpires elsewhere (in the work of the same Fasiani), precisely with regard to utilitarian evaluations relating to present and future goods (Principii [Principles], Vol. I, p. 162) and to the illusions of the subjects with regard to this, and the admission of the intervention of the judgment of the governing class with regard to presumption, on its part, of the utilitarian evaluations of the typical members of the community, in its view: "only the experience and the political sensitivity (of the State or governing class, of course) can allow the determination of the tribute in such a way as not to exceed the limits of the illusion of the majority".

In this way, inevitably, the same Fasiani, to whom I make reference in terms of a widespread position, must admit the intervention of the judgment of a third party (State) in the context of utilitarian evaluations that it hypothesises or imagines, to resolve mass problems, without measuring feelings or emotions in statistical and objective terms. He confirms this after repeating for the sake of theory the criticisms aimed at those who set problems of progressive imposition on the basis of the uniformity of decreasing utility of money: therefore, inevitably he admits (Vol. II) that it is not impossible to express some sensible judgment regarding the ophelimities of subjects; in other words, it is not absolutely "impossible" to reach some induction regarding the structure of the curve of utility (p. 68 of the 1941 edition) understood as collective or average by a third party (governing class) as I have already pointed out in Chapter III.

I point out the contradiction again because *one* of its propositions was contrasted by Fasiani with Graziani's intuition.

Having said this, I continue also in this chapter to approach theoretically and in hedonistic-subjective terms, as they have been hypothesised by the governing class that solves them in practice,

¹⁶⁶ Already quoted, to which I refer the reader, published in the "Annali di Statistica e di Economia" [Statistics and economy annals], Genoa 1936.

too, the problems of the qualitative differentiation of incomes with a scientific vision that remains coherent with the one I introduced regarding the quantitative differentiation of incomes: both are problems of the interpretation of the equality of the imposition.

[A clear proof of the intellectual discomfort, which leads to the contradiction or the partiality of demonstrations, can be found in the case of *Una interpretazione matematica della discriminazione delle aliquote nell'imposta di ricchezza mobile* [*A mathematical interpretation of the differentiation of tax rates for moveable wealth*] (“Rivista Bancaria” [Bank Journal], 1951) in a small note by V. Amato. Indeed, the author writes, “*the contributive capacity cannot be measured against incomes of a single year, but must refer to the overall income of each taxpayer*”. This refers therefore to the physical person as taxpayer (even though this tax objectively differentiates the tax rates aimed also at the incomes of juridical entities). The reference to the physical person is confirmed with the reference to the *necessary savings*, as the proportion of income exempt from tax.

Having recognised this, however: *a)* this thinking is based on the duration of incomes, *objectively* considered, for the purpose of making homogeneous the perpetual and temporary incomes, on the basis of a process of capitalisation; *b)* it takes into account *single* incomes, without warning that those in the categories of the tax on moveable wealth should be presumed to be the *only* or *overall* ones available to distinct subjects, and not as additions to a sum of incomes; *c)* it translates into mathematical terms, deducing from the difference in tax rates the presumed duration of work incomes as opposed to perpetual ones, from capital; *d)* it does not however explain the *why* of this presumed duration or of the necessary linked saving, in light of the subjective criterion or on the basis of the marginal utility, referring to the *overall* set of incomes presumed to be of different duration, probability and risk. This is the unacknowledged linchpin that directs the ancillary and technical and exercisable shifting of the hedonist premise, *not demonstrated* as being determinant to the differentiation of tax rates and corresponding to the idea that, as I have stated several times, the governing class has of the necessary savings, with respect to *overall* incomes of different natures].

In other words, this criticism does not deny that the *objective vision* has any gnoseologic worth or that it cannot explain any *part* of the phenomenon: think of those cases where the subject that produces and receives incomes is not a physical person but a collective entity or a juridical enterprise separate from the physical persons that give it life. In this case it is clear that *objectively* considered factors such as *duration, probability, degrees of uncertainty* contribute to giving a partial explanation to the differentiation of incomes subject to direct imposition, which continues in practice to provide a differentiation of real incomes, with expedients that betray a shifted solution to this problem.

However, the case where the producer, receiver and potential consumer is the physical person (as subject of both the economic event and the fiscal event of the subsequent taxation) is not only not negligible, but it can be said to be dominant, especially when the criterion of equality is introduced as an expression of justice. Mill, who nevertheless followed the actuaries, did criticize them on their own ground while he was studying objective factors, but he could not consider utilitarian evaluations of the subjects, as physical persons.

The presumption of the *need to save*, to be rational, needs to be linked to the hedonistic evaluation that is believed, on the part of the governing class – as it has been postulated in order to explain the progressive tax – to be formed by subjects that it imagines with regard to the utility of incomes differently available (duration, dynamic risk or uncertainty, etc.) with respect to the present and future needs appropriate to this kind of situation. From this derives the intuition of the quoted authors and the thought I expressed and that Borgatta confirmed, and which now needs to be illustrated with current theories: that the real context, in which to resolve the problem of the (not only quantitative, but also qualitative) differentiation of incomes, should be, in terms of a rational hypothesis but also in *reality*, in part¹⁶⁷, that of personal and general imposition: this would also include the case of incomes produced by juridical entities as, for the differentiation, it would be necessary to take into account the logical “time” of their utilisation after their receipt, in other words,

¹⁶⁷ Family levy, in Italy and similar tributes abroad.

their enjoyment or, even better, their enjoyability, being the time that I think Mill essentially had in mind, in my view.

V.

DEMONSTRATION OF THE QUALITATIVE DIFFERENTIATION ON HEDONISTIC BASIS (FIRST APPROXIMATION)

To explain the hedonistic bases of the qualitative differentiation of incomes it is necessary to refer to a notion of income that is essentially *dynamic*, in other words, referring to the *time* when the subject foresees having to satisfy any needs. This concept was not necessary in the case of the quantitative differentiation in which (theory of the progressive, proportional, etc., imposition) it was of interest to know, given certain needs, the hypothetical mode of evaluating different amounts in a utilitarian mode in respect of subjects that make up the mass, whose governing class it is presumed wants to interpret, from *its* point of view, the psychological reactions of typical subjects, with regard to the quantitative (income) variable instantly considered.

However, the introduction of the factor represented by different *durations* and in particular by the *uncertainty* that influences the duration and the existence of incomes, defined as more or less “founded” on capitals or combinations of capitals with work or deriving only from work, coherently compels non-static hypotheses; that is to say, it leads us to take into account subjective hedonistic evaluations such as are imagined to exist, in the judgment of the governing class, in typical taxpayers that must match more or less durable or probable incomes to future needs, according to the expectations subjectively considered by the subjects.

It now seems obvious (whether or not we follow Fisher’s vision, which came close to this trend in the last years of activity of the late American economist, or current concepts now linked to the real and monetary aspect) that *income* is viewed as a *series* of goods/assets that an economic *subject has available* over time or during a specific finite interval.

Let’s start with *monetary income*: it must be converted into physical or *real* income, *as* money is exchanged for other goods, destined for uses according to the preferences of the subject, so obtaining a *psychological* income.

This latter is constituted by the flow of utilities or satisfactions derived from the use of real income.

This latter vision implies the existence of a subject’s complex plan or economic landscape, and therefore the concept of subjective income (already indicated at para. IV-B, in a first approximation), intended as a set of incomes.

As I have, in the meantime, reserved myself the opportunity to define the *net subjective* income (while waiting to illustrate the purging process), I will say (recalling notions that the student should have) that it is obtained by adding together all the objective and monetary incomes that flow to this same person within a given time interval, and deducting the sum of the monetary values of goods and services that the person or subject has given up in order to obtain those individual incomes.

This subjective view of income has the merit of being compatible, as I have said, with that of Fisher (who conceived it initially exclusively as a flow of services and uses), because the uses of the economic goods (see above) cannot be conceived separately from a subject (JANNACCONE, *Lezioni di economia politica [Lessons of political economy]*, 1934) as they are determined by the desires, the preferences and the objectives of the subject or person who uses them.

Correlating the objectives that the subject proposes to achieve in future and the needs that he expects to satisfy with his expectations of available means, gives rise to the vision of income as a quantity to be considered in perspective. From this derives the vision (that has already been considered statistically in the explanation of the quantitative differentiation of incomes) of the net disposable, available or consumable available income, *over time*.

So we introduce typically dynamic elements: *a)* predictions of the future; *b)* the imperfect knowledge of it as the subject enters the realm of uncertainty and of risk in the sense of uninsurable uncertainty (discussed concept) or, better, linked to the subjective expectation of the person setting the

hedonistic plan projected into the future, on the basis of his own experience; c) rate or mode of variation of utility over time.

For the purposes of the problem of interest to us (research on the logical and hypothetical bases of qualitative differentiation), we presume unchanging future needs, simply for convenience of reasoning and we ascribe the uncertainty to availability of means (in other words to the series of incomes to meet needs) over time.

Having said this, it is necessary to integrate the reasoning that appears in the chapter regarding the mode of implementing equality of sacrifice determined by the imposition, differentiating incomes only quantitatively: in that set of temporal hypotheses limited to the *instant* (in which reasonings considered from the point of view of the governing class were referred to, interpreted as mass problems), the theoretical solutions are found on the basis of uniformity of the decreasing utility at the margin, referred to as the income available to the typical imagined subject, at *a given moment* in time (*static vision*).

However, modifying the above hypothesis with the pre-vision of future and with the uncertainty regarding the availability of means over time (keeping needs to be satisfied at the same level) and by adhering to the logical concept of the category of income as prospective quantity, it is necessary to relate the marginal utility of income to the use of it over *time*.

Research in this field has led to the conclusion by economists that the average attitude of the subjects, appraised with foresight, in the area of dynamic hypothesis, leads to a disposition of the doses of corresponding incomes or goods and to marginalistic utilitarian evaluations, different from those presumed in the static hypothesis of the decrease of utility for subsequent units of disposable means for the satisfaction of needs referred to the moment in time.

Making the marginal utility a function not only of the quantities of available income, but also of the probable use of them because of the uncertainty subjectively viewed of availability over time, the subject is presumed to be led to review his own distribution plan of the same means. That is to say, to put aside a *reserve* and to proceed, in his own plan, to what has been defined as “latent insurance” by recent theory, linking thus different and essentially greater utility to portions of means relating to the future than that which they would have at the present time, if leaving aside the solution of the problem of the satisfaction of needs over time.

Indicating marginal utility with U' , the condition of equilibrium will be compatible with the maximum satisfaction of the subject when a distribution of the probable or uncertain or more or less certain income can be found in the prospective plan such as to ensure the following equation:

$$U_1' = p_2 U_2' = p_3 U_3' = \dots = p_n U_n' \quad - \quad [I]$$

in which U_1' represents the marginal utility of the part of income that is certainly available and that can be destined for the satisfaction of needs, and the series of p represents the subjective probability correlated to the uncertainty (of the source: incomes more or less founded on capital and work and combinations thereof) of the means that can be destined for future needs.

If $p_1 = I$ represents the certainty of the availability of a portion of income whose marginal utility is expressed with U_1' , and p_2, p_3, \dots, p_n , fractions $< I$ of decreasing value with the decrease of the subjective probability of having means available to satisfy future needs, necessarily, for [I] to be true it is necessary for the marginal utility of the probable portions expressed by U_2', U_3', \dots, U_n' to increase progressively.

That is to say, to have absolute equality between the degrees of marginal utility it is necessary to neutralise or compensate hedonistically the degrees of uncertainty or of subjective probability that decreases as the incomes that make up the set available to the subject that intends to satisfy needs over time become ever less “founded”.

As we have made reference to the “latent insurance”, it is necessary to have a redistribution of availability, so that portions of income can be put aside for the future: from this derives the explanation of the so-called *need to save* that is presumed to be felt by those who have available means that are progressively less certain according to judgment of the subjects, imagined by the State.

Others have made reference to compensation factors relating to the probable losses of means for future needs.

We can express the portions of savings or reserves that normally increase in value with the increase of the interval of time that runs between the present and the future, to which reference is made for moments of probable availability of incomes, with r_2, r_3, \dots, r_n . This identifies portions to be put aside for the so-called "latent insurance" and such that, added to the portions of future expected incomes, will make up the absolute equality of marginal utilities in the distribution of the portions of income between needs of later periods in the course of time.

So that

$$(I - r_1) U'_1 = (I - r_2) U'_2 = (I - r_3) U'_3 = \dots = (I - r_n) U'_n \text{ [II]}$$

as the explicit mode of obtaining the equality of the marginal utilities of the portions of income assigned, in the calculation presumably carried out by the subject who arranges for a plan of availability of incomes unevenly funded or certain, over time.

[Clearly, when dealing with certain incomes $r = 0$, as is the case in fact presumed here of r_1 .]

The extent of the series r (savings) as a function of the subjective uncertainty, an extent such as it is *imagined* by the governing class for the State, should theoretically provide the guide for the deductions of taxable income as a function of the different degree of "foundedness" of incomes, in other words, a guide for the differentiation of tax rates at the same level of current monetary expression of incomes differently available in the future because differently founded.

VI.

FURTHER DEDUCTIONS AND WARNINGS ON DIFFERENTIATION

a) Up to now we have reasoned in abstract about the certainty or uncertainty of the availability of incomes, giving some examples of the differentiation of incomes as being more or less founded, depending on whether they are derived from the use of capital or of work.

It is necessary to further clarify that this theory applies generally, with differences in degree of the hypothesis of coefficients that express the subjective probability or compensation factors, for the following typical events object of fiscal imposition:

- a) incomes of uncertain sums and duration, compared to those with certain sums and duration;
- b) incomes of uncertain sum and certain duration (theoretically perpetual) compared to those of certain, perpetual and indefinitely lasting sums, from the point of view of the subject who makes the hedonistic calculations over time.

From these cases in which the differential factor is represented by the *uncertainty* of the sum or of the duration, we pass to that in which it is represented by only the diversity of the duration by degrees without essentially modifying the type of reasoning that the governing class presumes to be carried out by typical subjects.

Therefore, it is possible to assimilate with this order of reasoning and explanations, Graziani's intuition quoted above, which compared only perpetual and temporary incomes. The intuition was rejected by Fasiani for empirical reasons (difficulties of practical statistical verification, which we have also excluded as not necessary in this "*Corso*" [*Course*], in which the focus is on what might be the hypothetical judgment of the governing class on hedonistic reasonings by it presumed in typical representatives of the mass of taxpayers).

It is necessary moreover to note a contradiction in Fasiani's quoted essay: that is to say, he systematically uses the concepts and reasonings of Rosenstein-Rodan and Morgenstern with regard to the "economic period" and "time factor", in respect also of the economic plan of the consumer as hedonist and he nevertheless believed it was possible to discard the marginal utility variable on which these concepts necessarily pivot. Indeed, Morgenstern in particular tries to explain Gossen's law of levelling of marginal utilities (*Il fattore tempo nella dottrina del valore* [The time factor in the doctrine of value], "Annali di economia e di statistica" [Annals of economy and statistics], Genoa

University, 1936), referring to the calculation of the subjects to the time forecasting or waiting time. In particular, in this logical order that also validates Graziani's intuition, with the due warnings, and even more so this approach to the problem of differentiation, Morgenstern states: "The particle of income set aside today t_0 for the need x of it at point in time t_i , in this application, has a value greater than that it would have if it was used today as an addition". I do not make reference to other collections that would indicate that the plausible interpretations of the phenomenon or event of the differentiation of taxable incomes in the systems of direct imposition are necessarily linked to the uniformities regarding marginal utility, in the average of positive systems.

β) Furthermore, with this sort of reasoning, it is possible to account for the *coordination* between quantitative and qualitative differentiation of taxable incomes in a single logic order even when the two procedures are implemented by means of distinct events (direct personal and real taxation, separately) and not in a single more rational institution, according to the example that, in the Italian case, can be found in the family tax and that is traceable in the fundamental direct taxes of the English type.

For De Viti De Marco, the valiant thinker who did not consider it opportune to make space in his thinking for the variable represented by the marginal utility and its laws, "it seems contradictory that small capital incomes are benignly treated in regimes of progressive tax (that "aim to shift the tributary burden from smaller to larger incomes without differentiation of quality") to be then later harshly treated by differentiation (that "aims to shift the tributary burden from work incomes to capital incomes, without limitation of quantity")".

However, the intuition – in spite of these propositions – of the lack of substantial contradiction, led De Viti to find a coordination between the two institutions, on the "ground of *political battle*" "both qualifying the differentiation by quantity and weakening the rigours of progression towards greater work incomes, in respect of the greater capital incomes".

On the other hand, it is possible to remain in the scientific field, hypothesising that the political class implements a process of coordination between the two differentiations on the basis of presumptions it formulates regarding the psychological attitudes of a typical subject when faced with hedonistic plans involving, at even levels of needs, different means available to the subjects, in terms of quantity and quality (duration, certainty, general subjective probability).

So the margin of error is corrected so that the solution to the problem of the mode of distribution taxes, informed by the equality of sacrifices, could lead to the adoption of proportional and progressive or regressive taxes in the hypotheses studied in Chapter III of this course, precisely *leaving aside* the nature or quality of incomes that are here differentiated. For a coordination on a rational basis, such as that represented (para. V) by the trend of hedonistic uniformities on average supported by events, it is necessary to complete the logical system for the actuation of equality of the imposition, a rational vision that we would search for in vain on the grounds of "political battle", an historical event about which we still wait for obvious, univocal and universal scientific uniformities. This rational aspect of the problem justifies and explains once more why I had the chapter on differentiation first, as I indicated at the start.

[γ) What is not included in this rational scheme is the empirical explanation of the differentiation of personal and real tax rates for incomes of a *different nature*, when the additional or preeminent reason for qualitative differentiation is not rationally intrinsic, in other words linked to points of view listed in this chapter, but rather focuses on the empirical and extrinsic field of the technical modes of the application of the tax (degrees of approximations to reality, in the verifications). It is the norm to give the example of incomes and assets differently affected by taxes, depending on the degree of evasion in the context of verification of taxable incomes. It is an empirical criterion that has its practical influence but that does not require particular explanations in this course, which is concerned with accounting for aspects of phenomena that gravitate in the rational world, referred, in this case, to the behaviour and to the hedonistic evaluations of subjects and taxpayers that are typically considered when resolving the problem of distribution of taxes (or of the quantitative relationships between entities or incomes, etc., relationships typically modified in the context of a study of the effects of taxes by the interference of the tributary event).]

VII.

SECOND APPROXIMATION ANALYSIS FOR THE EXPLANATION OF QUALITATIVE DIFFERENTIATION

Let's, however, go back to the scheme that, to adopt the terms used in current English language theory, intends to "rationalise" the behaviour of typical subjects when faced with the wait for more or less certain incomes, in the introduction of the "uncertainty" variable in economic theory.

In demonstrating, in a first approximation, the logical necessity to deduct portions of income as not available (considering needs over time) or to reduce tax rates for the same reason, the thought has kept in mind a uniform psychological attitude, orientated in the sense of a normal preference for incomes that are certain or founded or lasting with respect to those that are uncertain or less founded or temporary.

This hypothesis could be considered more or less implicit or explicit and in any case dominant from Smith to Marshall. Let's leave aside Smith's vision of the relationship between profit rate and degree of risk, the first not increasing in the measure needed to compensate for the second factor of the economic calculus. Making reference to Marshall, however, according to whom, in having to choose between a certain income of 400 annual units and one that might have the probability of reaching 600 units but also of going down to 200, people of even temperament and who like to look forward prefer the certain one of 400 units. The uncertainty would not therefore (with the exception of those with great ambitions) be attractive to many and it would lead people to hesitate in the choice of a career. As a rule – according to Marshall – "certainty of a mediocre success (*aurea mediocritas*, as Horatio would say) is more attractive than an uncertain success that might have the same actuarial value". However, the same Marshall adds: "On the other hand, if an occupation offers few but exceptionally high recompense or awards, the attraction it exerts increases out of any proportion with its overall value" (*Principii [Principles]*, *op. cit.*, p. 550).

The temperament of Marshall's exception does not take anything away, I believe, from the normal case of the average subject, cautious and not fond of uncertainty.

Cannan, who makes reference to investments, outlines the figure of an average investor who prefers neither the most secure nor the riskiest employment, but belongs to a class of persons that has "neither the instinct of timidity nor that of the gambler" (*Dizionario di economia politica [Dictionary of political economy]*, Palgrave & Higgs Editors).

However, the most recent empirical observation, on the tastes of masses of operators (preference for risky actions and enterprises), especially due to the widening popularity of gambling (lotteries of various types) has led to the review of the hypotheses that explain the rationality of human behaviour in relation to typical subjects. So that, at the same level of actuarial value of incomes, often the *expected utility* appears greater than the most uncertain incomes. In other words, the psychological attitude favouring "games", risk and uncertainty is quite frequent, even if not normal.

It is necessary to warn that the reference is only to the function of total utility of *monetary* income and disregards other psychological and in any case non-monetary benefits that accompany, as motives, the monetary ones in determining the action of subjects as producers and, therefore, as subjects that enjoy income and other satisfactions linked with the productive activity.

It is also necessary to add that this hypothetical complication (that, as we will see, is useful in providing elements for the explanation of real facts in the context of qualitative differentiation of incomes) is compatible with what precedes with regard to the equilibrium of the hedonist over time, who tends (explanation on the basis of the finality principle, indicated in the *Introduction*) to the maximisation of expected utility.

This trend is admitted in the well-known work by Morgenstern and Neumann (*Theory of Games and Economic Behavior*, Princeton University Press, 1947 edition), a work that has a wide

wake of consensus and criticisms, in the hypothesis of the choice between various alternatives that imply risk and uncertainty.

Of course the resolutive variable, also in this case, is utility, that is to say, the progress of the curve of total utility, i.e. in relation to the *modes* of variation of the marginal utility.

I summarise the contraposition of hypotheses put forward by Friedman and Savage (in the article: *The Utility analysis of Choices involving risk*, in "Journal of Political Economics", No. 4, 1948), to resolve, as can be seen from the title, a general economic problem¹⁶⁸. I avail myself of a single representation to resolve the financial problem considered here, in a further approximation of the real phenomenon; a financial problem that the two authors probably did not even imagine would exist, and even less so in the terms that the vision of Neumann and Morgenstern and subsequent analyses allow me to introduce in the field of public finance.

Let x be the income of a consumption unit, in the most frequent case the physical person, and $u(x)$ the total utility linked to that income if it is considered as *certain*. This quantity of monetary income is measured here on the abscissa and the corresponding total utility is shown in the ordinate axis. Remaining in the hypothesis of only certain incomes, the hedonist will generally choose, all other things being equal, the income tending to the maximum, that will give him maximum utility. (This derives from the hypothesis of the total utility increasing with the increase in income). Let's consider these reasonings based on certain incomes, indicating them as alternative (B), opposed to that (A), which is of interest in this second approximation, in the further definition of the explanation of the rationality of qualitative differentiation.

Generally speaking, and without reference to the geometrical representation, let's indicate with (A) the alternative that implies risk or uncertainty, an alternative that includes two possibilities: I) that measured by the probability of $\alpha < 1$ of an income r_1 , and that measured by the probability $(1 - \alpha)$ of an income r_2 , greater than r_1 .

The utility of the alternative (B), in other words $u(x)$ is expressed with $u(B)$; the expected utility of the alternative (A) is expressed, given the coefficient of probability of the two possibilities indicated above, by

$$\varphi(A) = u(\alpha r_1) + u[(1 - \alpha) r_2].$$

In accordance with the hypotheses made, the hedonist will prefer the alternative (A) if $\varphi(A) > u(B)$. It is possible to imagine the opposite case and that of the indifference in relation to the signs that needs to be related to in the previous inequality.

Let's indicate with $v(A)$ the actuarial value of the same alternative. If $x = v$, and in spite of this the hedonist *prefers* the alternative (A), he will demonstrate preference for this risk. If he chooses the alternative (B) he demonstrates a preference for certainty, that is to say, $\varphi(A) < u(x)$, as $u(x) = u(B)$. In the first case [preference for the alternative (A)], it is said that the hedonist would be prepared to pay a determined sum for the "privilege to play", to use the terms used in the recent theory abroad. In the second case he would be prepared to pay to ensure an income for himself.

Passing to the graphical representation, if for every point of the abscissa the total utilities of the corresponding incomes were to be indicated on the ordinate (certain or equal to in actuarial terms) in the two hypotheses of preference or not for play, two curves are obtained, for example in the graph, mm' and nn' . It is clear that, in the case of an individual who loves play, the curve of the utility of incomes subject to risk is above that relative to the utility of certain incomes. From the graphic it is also possible to derive, with a quite obvious construction, which certain incomes give the hypothesised hedonist a satisfaction equal to that of an income linked to an unpredictable outcome, of lesser actuarial value. In the graph the two incomes $v(A)$ (actuarial value) and x (certain) appear to be equivalent, in the terms indicated.

¹⁶⁸ As such, it continues to be discussed, for example with reference to a significant prior theory by A. Alckian, in the same journal, June 1950.

Of course the representation of the opposite hypothesis is analogous to the preceding one. It is also clear that, in the case of an individual who is indifferent to the presence or otherwise of risk, the curves of total utility of certain and uncertain incomes (actuarial value) coincide.

There is no shortage of actual cases corresponding to these hypotheses on the function of utility and they can become relevant because of the mutual *imitation* between individuals. We can infer this evidence observing the passions of the masses for the risk of the type, both in countries with communist or capitalist order, where people prefer bets, lotteries, etc. This allows the State to derive from this attitude a non-negligible part of its own ordinary and extraordinary revenues (loans). (With regard to these real proofs of trends or preferences of the masses, see also what Friedman and Savage noted and make reference to qualified reviews of public finance in the various States of our time).

These empirical approaches, that lead to the inventiveness of hypotheses and of which some rational expression has been given here, are useful in this chapter to demonstrate in *a second approximation* how their interpretation, on the part of the governing class, can induce the same in order to give a solution to the problem of the qualitative differentiation of incomes, distinct according to the diverse degrees of uncertainty, *different* from that which could be presumed by implementing the *normal* hypothesis of the average subject that prefers, in any case, a certain income to an uncertain one, on the basis of his own utilitarian evaluations.

The consideration of logical hypotheses that are diverse and opposed (that the case studies of the various countries and States can more or less support, from an historical point of view) is useful in the meantime to explain how it is possible to *differentiate* “in favour” of *non-founded* and less certain incomes, *less than what might be imagined* by focusing reasonings on hypotheses (and corresponding facts) of *average* preference of typical subjects, for certain incomes, instead of by reasoning about subjects belonging to numerous classes of taxpayers who prefer uncertain incomes to certain ones, in the proportions in which the expected utility is more or less higher than the current one, according to the guiding graphic representation.

In other words, the *need to save* on the part of taxpayers with non-“founded” incomes, which is explained in para. V of this chapter, *may appear* to the governing class, which has to resolve the problem of the qualitative differentiation of (overall) incomes of physical persons, to be a *less intense* need than previously hypothesised. This is so if it can be demonstrated that, in place of the “need to save”, typical representatives of the mass of taxpayers may even feel the need to *spend* to gain the privilege of “playing” or to run the risk of probable incomes.

Furthermore, what appears in para. V and what is clarified in this paragraph, as a second approximation search, can be useful in giving an explanation of why one same problem, which is presumed to be abstract, can historically have different solutions, not only in relation to the diverse hypotheses put forward here, or more complex than these, but also as a function of the real different case histories (in relation to the evolution of tastes and the preferences of individuals and in particular of masses) that governing classes have to deal with, in different times and different countries, within the limits in which the theoretical visions here indicated can contribute to rationalising the same solutions, which we discuss here for purposes of pure knowledge.

If it is still needed, it is once more demonstrated how the utility variable (actual or expected, in other words, of certain or uncertain incomes, “founded” or not, etc.), which is the logical guide in the explanation of the quantitative differentiation of incomes, still has this decisive clarifying function when we want to give a rational and immanent meaning to the process of qualitative differentiation that rationally integrates quantitative differentiation from these points of view.

VIII.

THE “FUNCTION OF CONSUMPTION” IS INTRODUCED IN THE REASONING

The previous considerations were not, finally, in contrast with some of the current visions of the explanation of the rational behaviour of the subject as a consumer and saver: I refer to the studies prompted by the interpretation of facts, with some systematic reference to the *time* factor, due to Keynes and later critics and followers.

It is known that this author introduced, as a contribution that many recognise, the psychological attitudes of the subjects, linking them with the rate of variation of quantity of the economic system. The “propensity to consumption” is considered central to his theoretical construction: similarly he makes reference to expectations and to uncertainty, preparing the way, according to some, rather than building his own in this field.

In this logical order it has been demonstrated by the subsequent theory that the behaviour of the consumer is influenced by accumulated and available assets, by the current income and the *future*, in other words, expected, one, as well as the current and future prices and the rate of interest seen also from a prospective point of view. Furthermore an attempt has been made to explain in this way the *average* behaviour of groups of consumers. In this scheme too, as in traditional ones, the level of savings represents the result of the conflict between the desire of the typical subject to improve his own current or actual lifestyle, consuming more, and the desire to obtain a future benefit, through savings.

As in traditional schemes, it is imagined that the subject or individual (*i*) tends to maximise the function of utility:

$$U_i = F_i(C_i, B_i, \dots, B_{i,t,k})$$

that depends on consumption *C* and the availability of assets *B* in the present and in the future period *t* that it considers (time *t* of period *k*).

However, the function of consumption is expressed in terms such as, for example,

$$C_i = f(R_i, S_i, P_i, \dots, B_i)$$

that make the same consumption a function of *expected* income R_i , of the future variations of the interest rate s_i , of future prices P_i , of the future value B_i of assets or values already available to the subject (*i*) that sets the plan, as discount of the relative future incomes (different from the interest already considered separately).

From this derives (as consequence of the variation of the complementary fact that is consumption) a variation of the rate of saving. This variation is in relation, of course, as statistics also suggest, to the level of income of the individual subjects (and to the position they have in the distribution of the same incomes, as some would suggest).

The influence on the rate of savings of the prospective or forecast of *future income* deriving from *personal services* (salaries and wages) and of the prospective or future value of property assets, is underlined in some post-Keynesian writing, and in theory and on the basis of statistics relative to family budgets (for example in the summary monograph by J. S. DUESENBERY, *Income, saving and the theory of consumer behavior*, Harvard University Press, Cambridge, Mass. 1949). The uniformity that should be obvious, in the sense that the rate of savings increases more when the future income is made up of revenues of work of the type indicated above, is not explicitly formulated by this author in the context of *interpretation of statistics*, given the psychological case studies that influence the assessment of future incomes. In this context it can be formulated hypothetically, converging with what has been explained with regard to the rationality of the qualitative differentiation of incomes. Indeed, in the interpretation of the behaviour of the consumer, the Keynesian-type scheme also makes the rate of saving dependent on the *nature* of incomes that is hidden behind the *expectation* of them, naturally more or less probable or certain (and lasting).

However, capitals are also differentiated depending on their value over time, that is, the discount of the value of future income, on the basis of experience. When the income increases, the rate of saving tends to increase *if* the value of property assets considered increases less than proportionally and vice versa. This is an empirical uniformity, but one that confers a certain historical basis on the hypothesis that regards the evaluation of one of the variables concerning the future, which influences the behaviour of the beneficiary of income as consumer and saver.

This Keynesian type of point of view of the interpretation of the behaviour of the typical subject that *expects* incomes and value discounts over *time*, provides another logical proof of the

necessity of keeping account of the *need to save* of the subjects, as taxpayers. This is so when general and personal taxes are charged to current incomes that are necessarily in relation to the expectation of future incomes from work, capitals and their combination, which is appreciated by individuals in the context of hypotheses not unreal, to judge from empirical research that, at least in part, and this fact makes the inventiveness (of the same hypotheses).

It would appear that this vision confirms not only: 1) that, with regard to qualitative differentiation, it is necessary to consider, as it is suggested in these lessons, the *general* equilibrium of the taxpayer (beneficiary of income, consumer and, here, saver) over time and therefore the position of the subject when he disposes, today, and plans for the future, the set of incomes and of the property values available (personal imposition, therefore); but also 2) that a single logical order shapes all hypotheses, whether (a) the reasoning is based on traditional theory, updated particularly especially with the introduction of temporal elements that imply developments in the sense of economic dynamics; or (b) if weight is given to Keynesian-type visions that continue to influence, even if in the context of criticism, the evolution of economic theory.

APPENDIX

I) Incidentally, by making reference to Italian legislation as an example, I have observed the rationality of the family tax that includes *directly*, in the context of the same fiscal institution, both quantitative and qualitative differentiation, in harmony with the principles of the tax, as it has been demonstrated, rather than in contradiction to it.

I have also mentioned (and I return to this point to allow the student to interpret from this point of view the regulations of positive law that are the reason for my long-standing request for a specialist treatment of this matter) the lack of coexistence of the two institutions in the complementary Italian tax and inappropriate attempts of the legislation to apply the logic of qualitative differentiation in the primarily real imposition such as that applied with the Italian tax on moveable wealth.

From the same point of view just as inappropriate are, in a logical context, the theoretical argumentations found in Cosciani's *Riforma tributaria [Tax reform]* (La Nuova Italia, Florence, 1950) and in Fasiani *Principi [Principles]* (1952 edition).

α) Such impropriety does *not* refer to the differentiation of *tax rates*, that is to say, to the empirical attempt to take into account the diversity of incomes, objectively, depending on their presumed relative *risk* in function of the source being more or less made up of perpetual or less lasting capital and from work; this is a factor that can be taken into account in the precise context offered by real imposition. This essentially compares, from this point of view, incomes deriving from land as a theoretically perpetual and generally at least a certain source with those deriving from buildings and riskier moveable wealth; it is again the real imposition that, in the context of the tax on moveable wealth, graduates the tax rate in function of the risk presumed to be linked to the lesser contribution of the capital factor compared to that represented by work, as we move from incomes from pure capital (cat. A) to the mixed incomes from capital and work (cat. B), or pure work (cat. C₁ and C₂) (differentiated for the reasons of administrative characteristics mentioned in paragraph VI-y of this chapter). It is possible in fact, from this point of view, to explain the differentiation "in favour" of persons, also *juridical ones*, producing mixed incomes from capital and work, real estate companies, etc.

β) What appears to be inappropriate, however, is the introduction of what, for example in Italian law no. 25 of 11 January 1951, is referred to as *allowance*, which was intended to be limited to physical persons and to "companies or associations made up of two or more physical persons, as a single subject". Indeed, the implicit argument that probably led to the introduction of the allowance, on the basis of examples from foreign systems (which implement it, however, in the context of general imposition) as it applies to the physical person, relates to the "need to save" in the sense that has been extensively explained in the chapter this note refers to. To be able to admit this allowance in the context of an essential real tax such as that on moveable wealth, we must forget that this is a real tax and consider it, at least with regard to this aspect, as personal imposition. This hybrid occurs in fact in Italy, where the qualitative differentiation could directly and more rationally be referred to as the complementary rate on income.

In fact in the end an allowance of 240,000 liras is applied to categories B, C₁ and C₂ but it is granted only once to the subject who benefits from all three types of income. We consider, therefore, out of its appropriate context (which would be the complementary tax), the sum of, furthermore partial, *some* incomes in the sense of their overall and simultaneous consideration, granting the allowance once only to the *overall income*, granting it first to incomes in cat. C₂, then those in cat. C₁, and then to those in cat. B.

Of course the careful legislator is aware that the complementary tax on income would have been a more suitable tax for this differentiation on the basis of "need to save", the explanation that was given earlier with regard to qualitative differentiation. In fact, by absorbing the minimum taxable income (which remains much lower, at 36,000 liras for juridical persons) and increasing it somewhat as empirical evidence, by logical necessity it is admitted that the taxpayer, a physical person, can contemplate the *entirety* of the hedonistic world, which leads us to consider the overall *quantity* of disposable income available to the physical person. However, the overall quantity admitted by the

quoted law of 1951 for moveable wealth is both imperfect and partial, because it neglects the availability of incomes from lands and buildings and those from pure capital.

Therefore the argument is revisited in the context of the complementary tax by *excluding* the allowance from the part (partial “quantity”) of incomes subject to the tax on moveable wealth cats B, C₁, and C₂, that have already benefited in the context of real taxation. An allowance of 240,000 liras is granted to all *global* incomes, regardless of their composition, perhaps presuming that at least one corresponding part of overall income is income from work or mixed income (which it cannot be); in other words by admitting that funded and certain incomes, or certainly expected, perpetual, etc., also must guarantee a minimum (allowance) to provide for one’s own future or the future of one’s own (deductions for dependent persons at the rate of 50,000 liras each). This denies the qualitative differentiation, confusing it with the quantitative one, and making quantitative differentiation worse, as an institution of equal distribution because the allowance is granted also to subjects with *high* incomes subject to the highest tax rate, in which cases it translates into quantitative differentiation in the context of progression. A contradiction in terms is, therefore, due to the fact that a partial argument was introduced in the explanation of the tax on moveable wealth, an argument that relates to the reasons expressed in the previous chapter, rather than implementing it in a logical context, such as the complementary imposition on income, as the family tax would be.

Finally, if the allowance is considered as an updated minimum non-taxable income, we find ourselves back in the field of only quantitative differentiation and the new logical problem does not arise (qualitative differentiation).

II) An *indirect* method to refine, both from the point of view of the objective risk (tax on moveable wealth charged also to non-physical persons) and from the point of view of the need to save, as it has been illustrated through the arguments in this chapter, (presumption that would introduce qualitative differentiation on the complementary tax) is represented by the coexistence of taxes on income and on assets. More specifically: *a*) for the risk objectively considered, adding a proportional tax on the corresponding assets to the real tax on produced incomes; *b*) for the presumed need to save by having a progressive tax on the overall asset coexist alongside a progressive complementary tax on the available income of physical persons.

This contrast (*a*, *b*) that I expressed in the article on the basis of fiscal reform, to which I refer the reader (“Giornale degli Economisti” [Economist Journal], February 1940), was not understood by the legislators of the time, who introduced the ordinary tax on assets in Italy, and by some of their advisers, who were also the actual collaborators on the projects and laws to which it refers (1951). The 1939 ordinary tax on assets (later abolished for purchases in the post-war period), as it was not a general and proportional tax, could have had the function of refining the objectively considered differentiation of incomes, because of their differing levels of risk, produced by physical and juridical persons, precisely by targeting the source if this had been in the form, even if partially, of assets.

Indeed, in the context of the same category of mixed incomes, the proportions of assets and work are not uniform, if enterprises that are highly capitalised, especially in the form of an anonymous company, are compared with small industrial and commercial enterprises, whose income derives essentially from human work.

However, this exclusive function of the proportional tax on assets was not understood by the authors of the law, including the already mentioned advisers, who wanted to ascribe the basis of the tax to pure economic logic.

When they were apprised of this, summarily, through the relative communication from the Council of Ministries of 30 September 1939, various commentators in the daily press focused their attention on the illustration of the function of the tax on assets in a sense that appeared to me to be unilateral and not correct: that is to say, only and especially the corrective function on the complementary tax on income was identified in the new tax.

From my point of view, in the comment I refer to above, I noted as not rationally identifiable in the new tax the characteristics and the functions of the complementary tax on assets, such as it had been considered in theoretical schemes or implemented in practice for the purpose of integrating the complementary tax on income. I saw in the fiscal reform the accentuation of the differentiation already present in real taxes charged to incomes. The reasons for my opinion, to which I return in this

context, which is more suited to a wider treatment of the matter, were underlined and accepted by some experts, in particular those who were like me concerned by issues of principle.

What should then instead have been the formal structure of the new ordinary tax on assets in order to rationally address the purpose of completing and integrating the fiscal function of the personal and progressive tax on income, complementing it rather than replacing it?

Those who have just started in this field know that financial theory supported by fiscal experience has led in many states to the concept of a tax on assets (added to the complementary tax on income) as a *personal* and *progressive* tax. Already the revenue tax in place in Italy presumes that, as the overall income available to the physical person grows, so does the capacity to support additional burdens, other than those represented by real taxes. The totality of incomes allows the comparison of the more affluent with the less well off, the “rich” and the “poor” protagonists of the “battle” for the distribution of the cost of public services.

The personal tax aims, as we have seen according to how it is ordered, to differentiate incomes according to their extent, with the application of progressive tax rates as the overall income increases. And as, even though the taxable income is made up of the sum of net incomes (produced and received), we want to understand what is the total income *available* to the physical person or family unit, a subjective differentiation criterion is introduced in the evaluation of the degree of availability of income, by means of allowances (for each “dependent” person, for interest on debts of any nature, for premiums due to insurance institutions) that aim to take into account subjective elements.

Having said that, it would have been possible to add a tax on the *totality* of *assets* for each physical person to the tax charged progressively to overall available incomes depending on their extent and taking into account subjective elements that affect their availability.

Overall incomes, higher or lower, will be more or less *available* (need to save) depending on the overall composition of the relative corresponding sources. If there are reasons to introduce a personal and progressive tax on income, the same reasons should be considered as applying when this form of personal taxation is refined, by coordinating the permanent taxation of assets with it.

The late Ministry Meda seemed to think along the same logical lines of reasoning when, with the purpose of targeting capital more heavily than work incomes (the same aims that the tax we are considering is supposed to have, according to the authors of the law), he suggested the institution of the *personal* tax charged to the physical person as owner of assets, having as object the accumulation of individual assets.

With regard to the trend in the tax rate, in principle (on the basis of the considerations of the illustrious experts making up the reform committee), Meda was in favour of progressivity: “There is no reason in *principle*, for those of us who perceive the tax on assets as a variation of the tax on income, to have to choose between proportionality and progressivity other than that which can shed light on the choice between the two methods of treatment of the tax on income: when it is thought to be correct to apply the principle of progressivity to income, there is no reason (in principle) not to apply it equally to assets” (*La riforma generale delle imposte dirette sui redditi [General reform of direct taxes on income]*, Treves, 1920).

The reasons that lead to a preference for proportionality are mainly of a *practical* nature. To generate “financial illusions”, it was thought to be more convenient to introduce and “settle” a new tax “by presenting it under the form of proportional tax” with a low tax rate. It was also desirable to avoid incentives for evasion, or rather it was planned to ascertain with a greater approximation to reality the extent of assets, so as to take this into account to determine, in due course, the value of the hereditary assets subject to succession tax. The circumstance whereby the proposed tax on assets would have acted simultaneously with the succession tax, which is an important branch of personal assets taxation to which the progressive characteristic can be limited, had more theoretical value. Einaudi also suggested a “contingent” reason, represented by the absence of taxation for State bonds, declared exempt from any type of current and future tax. As such a large portion of taxable matter is outside the scope of taxation, there would have been no certainty of being able to charge with the highest tax rates the owners of the greatest assets, when such assets were invested in exempt State

bonds¹⁶⁹. The same author mentioned Benini's "statistical law" according to which a *proportional tax on assets* works as if it were a *progressive tax on income*. In justifying the proportionality of the ordinary tax on assets, in my view we go beyond the theoretical conclusion of the illustrious statistician who was perhaps the first to regret the excessive reliance on the results of a rather remarkable scientific research, assuming it to be the standard approach in fiscal circumstances different from those considered by Prof. Benini.

Before remembering how Meda had already taken this into account in summing up the experts' arguments and stating that there was no reason in principle to exclude, in spite of the above mentioned statistical correlation, the progressivity of the tax rate as one of the attributes of the characteristics of taxation of overall assets, I will recall the reservations and warnings used by Benini to limit the theoretical and real extent of the uniformity linked primarily to his name. I had already recalled¹⁷⁰ how Benini, responding to the director of the "Rivista di diritto finanziario e scienza delle finanze" [Journal of financial law and the science of finance] on the range of the formula found by G. Lasorsa (double incomes from double assets), stated that he did not think it to be "admissible to have a simple and direct proportionality between income and asset, because this would equate to the assumption that the *rich* convert into *assets the same percentage of income* as the middle class or the majority of people who live hand to mouth". He did not think that the statistical notes confirmed this. Benini thought that who has at his disposable an *income double* that of another saves "much more" than double: and nevertheless he had reservations in confirming the similarity of his formula in 1906. Already some months earlier¹⁷¹ it was possible to read about some other of Benini's reservations in the sense that the verifications attempted on the basis of double entry tables for total incomes and assets in different countries did not always provide univocal proofs of the already mentioned correlation law. Among other things, the percentage of income that in some countries families do not spend but assign to savings is not very different between social classes. In any case, the scientist's scruples extend to the point of warning that it is best not to give too much weight to his fiscal ~~inference~~ theorem, according to which: "a proportional tax on income works as if it were a progressive tax on the total corresponding incomes".

This formula, which establishes (if used with great care) a relationship between *total income and corresponding assets*, was taken into account as a guide in the reform considered here. The Ministry of Finance in 1939, responding during parliamentary work to members of legislative committees favourable to the progressivity of the tax rate of the ordinary tax on assets, among other things thought proportional tax rates preferable, both because this is a real tax, and because the asset tax "practically represents a progressive tax on funded incomes". I do not however believe that this interpretation of Benini's formula, in reality, is completely adequate. Indeed, as I have already recalled, a proportional tax on assets is progressive on the *entire income* of the taxpayer (*and not on the individual funded incomes*).

To clarify the relationship between assets and overall incomes on the one hand, and incomes from the same assets on the other, I make reference to the illustration by Barone who, without making explicit reference to Benini's statistical uniformity, demonstrates that "a proportional tax on assets is a progressive tax on income".

Completing Barone's representation (figure 87 in "Principi di Economia Finanziaria" [Principles of financial economy]), we indicate the assets on the abscissa axis and incomes on the ordinate axis. Total or global incomes result from the sum of the incomes deriving from assets, plus the sum of incomes deriving from work.

Assuming two assets *Op* and *Op'*, the second double the first, it can be said (generally or "roughly", as Barone observes and the statisticians and economists mentioned above believe) that the *corresponding incomes* are *proportional* to the same assets.

¹⁶⁹ *La guerra e il sistema tributario italiano [The war and the Italian tax system]*, Bari, Laterza, 1927.

¹⁷⁰ In the quoted article on the characteristics of the new levy.

¹⁷¹ In the May–June issue of the same journal.

This can be noted by measuring the incomes of, presumably pure assets, dp and $d'p'$ on the line Or . In this case a tax that is proportional to the *assets* is also proportional to the corresponding incomes.



Figura 19.

Let's consider, however, *total* incomes represented, as it has been said earlier, by the *sum* of incomes from assets and from work. In this hypothesis the total income corresponding to asset Op' and which in the geometrical representation is equal to bp' , does not have the same *relationship* that ap has with respect to asset Op .

Indeed, the *inclination* of Oa is different from that of Ob and, generally speaking, *decreases as the assets grow*. (The relationships would be the same *if* incomes were measured by the *same* line Oa , its dotted extension identifying the height $b'p'$ here traced only hypothetically, and in contrast with the empirical-statistical uniformities that confirm the relationship of "non-proportionality between total incomes and assets").

Within the limits in which the statistical uniformity applies in the sense indicated here, between total incomes and concurrent assets, it is clear that a proportional tax on assets acts as a progressive tax on total income. This is the consequence of the reducing relationship between overall income and assets when this latter increases.

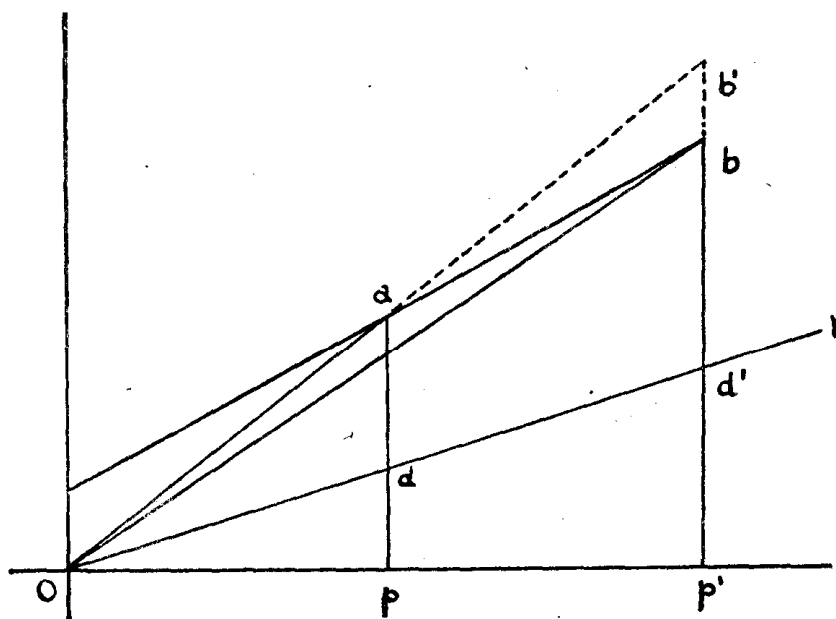
When Meda took into account Benini's suggestive investigations, on the basis of the elements supplied by the study Committee, he completed the table of the illustrious statisticians so as to demonstrate that a proportional tax on assets is also *proportional* to the *part* of total income that derives from assets (that is to say, funded incomes). The constant tax rate becomes progressive with respect to *total* income, made up of incomes from assets and incomes from work. In the case of interest to us here, of a tax on assets balancing existing taxes on incomes, as has been seen earlier, the objective of the authors of the law is that of targeting in a differential way *only* incomes "*funded*" on capital elements. For this reason it is not possible to make reference, without any limitation, to Benini's correlation to identify a case of rational progressivity in the ordinary imposition on assets such as that envisaged by the new legislation.

In projecting the introduction of the tax on assets as a tribute complementing the personal tax on total income, Meda himself (and the study Committee with him) declared that Benini's conclusions, despite the reservations of the same author, could be considered to be applicable to the case of the tax on assets as an "independent" and not a "supplementary" tribute. At Benini's time there did not exist a progressive tax on total income in many tax systems and the pros and cons of the progressivity of the imposition was discussed only in a theoretical way. The proportional tax on

assets, acting as a progressive tax on total income (so wrote Benini), would have implemented the principle of progression “without the risk of being accused of arbitrariness, which is normally the objection to the application of this principle”.

I think that what precedes is sufficient to explain how the statistical correlation in object has been applied, not entirely with justification. At any rate, and also in the case in which it would not be possible to apply the new progressive tax on *individual* funded incomes, there would occur, as I have explained earlier, the not rationally acceptable case of a progressive taxation of *individual* incomes in the context of *real* taxation.

Furthermore, an additional point worthy of careful consideration is the one that follows, identifiable in the authors of the law and some academics who have illustrated it in its original text. For the purposes of financial policy, as explained by academics, it was the intention to exempt assets made up of *State bonds* (or similar from the point of view of the exemption from any current and future tax) and some other exemptions were allowed that, like the one in favour of bonds, would not be admissible in the context of personal imposition. Instead of arranging the tax as a personal tribute (with the appropriate attributes of this type of institution) if aimed at integrating the complementary tax, its structure was made *dependent* on that which (extension of exemptions) should, if anything, be the consequence of logical criteria of distribution of taxes.

In turn, the *proportionality* of the nominal tax rate was a *consequence* of the exemption of various and important sources of capital-based incomes.

Indeed, in terms of the tax on assets, I have not read of any reasons of a systematic nature that exclude the personality of the institution and the *progressivity* of the tax rate (this is understood to be at comparable levels of forecast tax taxes). The few indications to the contrary, of some distinguished theoretician, have identified difficulties of administrative nature or the risk of evasion, in other words unfavourable psychological effects: circumstances recognised by all as being irrelevant to the logic of the system.

What I write here with regard to the claimed objective of wanting to rationally and directly integrate with the ordinary tax on assets the complementary tax, which does not differentiate addition to the total being considered, from the point of view of the differentiation between incomes from capital, from work and mixed.

In conclusion, the ordinary *proportional* tax on assets, if well designed, could be a rational tribute when it is considered as a means of achieving more limited and yet converging objectives than those taken into consideration up to now, that is to say, if it considered as an institution that *accentuates* and refines the *differentiation of incomes* that is already in place in the context of *direct real taxation*. This is the second objective put forward by the authors of the law, when they intended to concentrate the pressure of new burdens on more funded incomes.

CHAPTER VII

ABOUT THE “DOUBLE TAXATION OF SAVINGS”

I.

THE SOLUTION TO THE PROBLEM OF EQUAL TAXATION IS IMPLICIT IN THE HYPOTHETICAL DEFINITION OF THE TAXABLE OBJECT

1) The long treatise of the theme of differentiation of taxable incomes, in the sense of incomes subject to direct tributes, corresponds to the content of the science of finance as a study of the modes of distribution of the burden to meet (collection of) the cost of public services. Compliance with the criterion of equality is achieved through the demonstration, from an objective and subjective point of view, of the logical need for a formally unequal imposition, to prevent an essentially equal treatment of taxable incomes subject to direct tributes.

Indeed in dealing with differentiation, it has been argued, keeping in mind that two quantities of income that are homogeneous and equal in their monetary expression may not be economically equivalent if they are available under different conditions, for example in terms of time and of risk.

In the preceding discussions I have carried out a “generous” and wide interpretation of J. Stuart Mill’s argument, especially in the introduction of the hedonistic and subjective vision that, for the purposes of equality of imposition, requires the overall economic situation of the subject to be rationally considered, as typically presumed to be viewed from the governing class.

2) However, its scientific merit, which I have tried to extrapolate from the interpretation whereby I thought it opportune to give to some quoted statements of the established English academic, is clouded by the doubt he introduced, with a presumed criticism of the direct “income tax” system being liable to lead to a double taxation of the same quantity of wealth. It was as if he had thrown the bone of contention among the economists, as a reward in the battle of ideas, the one who proved himself worthy in the discovery of the truth: this caused about a century’s worth of discussions around this idea that Einaudi, who has kept the debate lively for 40 years from the point of view of his convictions, defined as “extraordinary and extravagant controversy of the taxation of savings”. [The exemption of this has been considered in light of a very different problem of equality in the previous chapter on differentiation.]

Stuart Mill’s vision, according to Fisher’s interpretation, which I demonstrate to be a partial one, contrary to the view of all those who have dealt with this issue, appears to have been circulated, with his compliance with Mill’s theory, by the American economist in his well-known 1906 work (*The nature of Capital and Income*, translated by the Economist Library, Series V, Vol. IV). It is certain that Fisher had a direct influence on Einaudi. However, as I will demonstrate here, being the first of all those who have considered this issue, that only a definition that includes in the concept of income a simultaneous increase in value of a capital and its relative income could justify the compliance of Fisher with the theory of the English economist. Another group of (total or partial) supporters of the so-called double taxation, in the sense that will be specified, came together alongside this illustrious triad of staunch supporters of Mill’s considerations. Borgatta, Del Vecchio, Fasiani (in the first instance and from specific points of view, as I will recall) and Pigou, for example, were among this group. The same claimed inequality of imposition or double taxation of savings was denied by Ricci, De Viti, Lolini, by Loria for some aspects, Cabiati, Griziotti, Fubini, generally¹⁷²; by Stamp, Black, Guillebaud, MacGregor, Masci, Capodaglio, L. Rossi, Villani, to follow a certain chronological order, with different arguments and adhesion to the main ones of those arguments. The main bibliography is to be found in some of their works, which I will quote later.

Some aspects of the thought of those quoted or of other authors will be covered in what I will observe hereafter. For now, before reconfirming with some further explicative development the view I expressed more than ten years ago and developed prior to that, I want to present the text of Mill’s

¹⁷² In the *Lezioni di scienza delle finanze [Lessons of the science of finance]*, pp. 157-8, Cedam 1934.

concept, around which “writers from all over the world have picked upon” for one reason (of tenacity) that does not reside, as Fasiani believes, “in the usual anti-scientific concern with the practical consequences of the theory”, which is appropriated eventually by the legislator in the sense of “reducing tributary burden on savings” and to increase “the pressure on consumption”. However, more or less adequate arguments of those developed by those who have opposed Mill’s theory, focus on the field of logic or of the attempts, at least, to bring this question into the domain of pure theory, to correct and eliminate errors, oversights, blunders or sophisms.

This can be read in Mill’s *Principles of Political Economy* (Vol. II, para. 4): “If it were possible to rely on the taxpayer’s conscience, or if it were possible to guarantee to a sufficient extent, with checks and expedients, the precisions of declarations, the most correct way to distribute the tax on income would be to tax only that part of income that is destined for expenditure, and exempt the part saved. This is so because when this part is saved and invested (and all savings are, generally speaking, invested), it will pay a tax on the interest or profit that will derive from it, in spite of the fact that the capital has already been taxed. If savings are not exempt from income tax, taxpayers are taxed twice on the part that is saved and once on the part that is consumed. The subject who completely spends his income pays a tax of 3% and nothing else; on the other hand, if he saves one part and invests it in public funds, in addition to the 3% that he has paid on the capital he pays also 3% on the yearly interest, which is equivalent to a second lot of 3% on the capital. So that, while only 3% is paid on unproductive expenditure, 6% is paid on savings or, more precisely, 3% on the original amount and another 3% on the residual 97%. The defect of equality that is so determined at the expense of foresight and savings is not only inappropriate but also unjust. To charge a tax on the invested sum and then also on the fruits of the investment means charging twice the taxpayer’s same portion of wealth. The capital and the interest cannot simultaneously represent the taxpayer’s income: this means accounting for the same sum twice; if he gets any interest it is because he does not use the capital; if he uses the capital he does not receive any interest. Nevertheless, as he is not free to choose, he is charged as if could have both, the advantage of savings and that of consumption.”

This long presentation of Mill’s view is normally simplified and interpreted by saying, more or less, with different numerical examples and that I report in the present simplification, as follows.

Let’s have two incomes of 100 units of two taxpayers, subject to a tax of 20%. The residual 80 units are consumed by one of the two. The other saves 80 units and invests them at 5%, deriving an annual income from it of 4 units.

The annual income of 4 units is, in turn, taxed on the basis of the tax rate of 20%: this results in a net income of 3.20 units.

If we calculate the actual value of the 0.80 tax in perpetuity at 5%, we obtain the total of 16 units and the 80 units are reduced to 64.

Ultimately it is as if the second taxpayer is responsible for a tributary burden of 36 units (on an income of 100) while for the first this is 20.

In conclusion, with this system there is an infringement on the Mill-type postulate of equality that indicates that “two equal incomes should be equally taxed”, according to the synthesis of one of these same ideas.

3) In part anticipating my thinking, what is not expressed in these terms and that needs to be explicitly stated to ensure that the postulate is satisfied is this: “two incomes equally *defined* should be equally taxed”.

The integration of the postulate might appear to be a formality. Conversely, in the case of the so-called theory of double taxation of savings, I have made it clear to students, in what might appear to be a paradox, that *the solution is already hidden in the hypothetical definition of the object of the imposition*, a solution of the equality of the imposition that is rational and coherent.

As a student and disciple of the illustrious Einaudi, in the text book in which the postulate of equality inspired an entire vision of the world, I read that, according to Stuart Mill and Fisher, taxation of “earned income” leads to the double taxation of the same quantity of wealth (*Corso di scienza della finanza [Course of the science of finance]*, “La Riforma sociale” [Social Reform], Turin, 1916). However, before reproducing Mill’s view, which I have introduced above, Einaudi warned that “the same Mill did not bother to define explicitly what he meant by income; however, from the

context of the argument it can be understood that by “income” he meant what was defined above as *earned*¹⁷³.

The definition is essential also and above all in the demonstration of the theory that intends to highlight the violation of the equality postulate when the object is “earned” income. This should all the more have been indicated by Stuart Mill, who is referred to, for example by Poincaré, mentioned in the *Introduction (La science et l’Hypothèse [Science and hypothesis], op. cit., p. 59)*, as the author who “claimed that each definition contains an axiom, because the existence of the defined object is implicitly stated by the definition”. Poincaré hastens to add that, for mathematicians, an entity exists as long as its definition does not imply a contradiction with itself and with the propositions previously admitted. The French thinker had already made reference to Stuart Mill (in *Science et Méthode [Science and methodology], op.cit., p. 162*) to say that Mill’s thinking becomes more precise if it is rectified by saying that the existence of the object signifies that there is no contradiction. And this is so after the premise that to define something means not only to reveal the defined object but also the objects near it, from which it is necessary to differentiate it (p. 141). In current philosophical thought and scientific methodology, to define is to explain the characteristics that objects have *in common*. The arbitrariness of the definition is in the designation and the enumeration of the common characteristics.

Having made this premise, and using the elements of *duration* (time) or *use* they are destined for, which is *common* to several types, we will see how, in a famous example by Fisher, Mill’s denial falls (capital and interest cannot both be part of income from the same): therefore the equality of the imposition of sums equally “defined” as incomes is demonstrated.

However, I want to remain with the propositions of the English economist for now. In this case then, what becomes decisive in my view is the adoption of a definition of the object of the direct imposition on income that avoids the contradiction expressed by Mill and highlighted by followers and critics of his theory, in terms of the part of it that I believe is worthy of being considered and which is, to paraphrase the classic English academic, that “capital and interest cannot be part simultaneously or at the same time of the taxpayer’s income”.

Indeed, a definition of income that is free of contradiction in this sense is already considered in the treatment of the differentiation of taxable incomes, in this course of lessons. As the same Einaudi only found interesting (in respect of the theory) the calculation of the income of the person or subject, I will recall that I have already written that “the subjective net income is obtained by adding together all the objective and monetary incomes that flow to this same person within a given time interval, and deducting the sum of the monetary values of goods and services that the person or subject has given up to obtain those individual incomes”.

Even though this vision lends itself mainly to the explanation of the object of the personal and overall imposition, it is for now important to observe that there is no contradiction in this, in terms of considering simultaneously as the subject of the imposition both the instrumental assets or capitals and their relative income.

For the purpose of the demonstration of the coherence of the argument without contradiction, it is now possible to define the net income produced and received in the exchange by the subject as a sum of money, considered *before* it is available to the same subject for saving or for consumption and *after* he has integrated the capital that generates the income, to make constant the capital. It is one of the many definitions available and it is useful in that it contrasts this concept with that of an income that the subject has *already* allocated to savings and consumption. Greatly stressing the moment of production (and the inflow of produced income into the hands of the subject or rather the subjects to whom the equality postulate is intended to be applied) is interesting, in part not least because this

¹⁷³ “*Earned* income, for the individual, is the consumed income, or the consumed wealth *plus* the increase that occurs during the period in consideration with respect to the assets or capital owned at the initial point (an increase that can be savings in the common sense of the word, implemented with part of the fruits of wealth, in other words an increase in the value of the assets), and *less* the decrease in value of the assets with respect to the initial point (a decrease due to objective wear and tear or to the consumption of it by the owner).” (p. 178 of the *Corso [Course]*).

(production) process is taken into account in reputable denials of the theory of the double taxation of savings (De Viti De Marco, Ricci and others).

The reader may wonder at this insistence on the definition of the object of the (direct) imposition on income, given that at first (reading so on p. 44 of the *Contributo all'«ottima» imposta [Contribution of the "optimum" tax]*¹⁷⁴) the definition of income does not appear to be a "starting point". (It is understood to be an abstract definition that meets the theoretical needs of demonstration of the postulate of the equality of the imposition, not necessarily a concept adopted by any form of legislation.)

Later on, however, the same author does not disagree with De Vito De Marco when, presenting the specific theory, he finds that *the essential questions is: "what is the income the tax due by each citizen must be proportional to?"* He also admits that "only after solving this, will it be possible to ask the particular questions relating to the direct tax on income or indirect tax on consumption or on transfers and those relating to each individual tax on income" (p. 85).

The adoption of the definition is so decisive that the claimed violation of the postulate of the equality of imposition, of which Fisher, after Mill and in fact highlighting Mill's position, was the greatest supporter in particular from 1937–1939, dissipates into nothing by destroying the bases of the theory of the double taxation of savings. It does so in particular if given homogeneous objects are adopted, with *common* characteristics, as I said before, for all subjects or taxpayers, by taxing income directly and not the capital at the same time. From this point of view, whoever considers some of the statements in Fisher's demonstration in the quoted text (which I have sourced in the Economist Library), cannot but agree with what I now state, to further explain my position, which was concisely expressed with regard to the controversy at the time.

Indeed, Fisher's treatise is bound by the definition of income: *a)* "in its true meaning"; and *b)* in its "spurious interpretation". In the first case there is no violation of the postulate of equality; in the second (which considers the *increase* of capital as income) there is confusion between income and capital, and therefore taxation of the capital and of the income that the subject derives from the accumulation (double taxation).

Generally speaking, "according to the different interpretations given to the word *income*, there will be different consequences", Fisher states, referring to the famous example of the three brothers. In this, it is assumed that each brother inherits the same *assets* (I stress the term because it is essential in the argument) of the value of 10,000 units. The first invests his 10,000 units in a perpetual annuity of 500 units per year; the second saves it in a deposit account to accumulate 5% per annum for 14 years, at which time it has doubled in value and is then invested in an perpetual annuity of 1,000 units; the third, being a big spender, purchases an annuity of 2,000 per annum for six years only. Let's presume a *tax on income*¹⁷⁵, Fisher writes, referring later to "income that actually *derives* from

¹⁷⁴ In Einaudi's "Annali di Economia" [Economy Annals], Milan, 1929.

¹⁷⁵ So that the student can understand how there is no confusion in the definition *a)* of income, which Fisher takes into account in reaching the conclusion of *equal* taxation, and can be made aware of the expressions used by Fisher, that clearly refer to the direct imposition of *income* "deriving" from capital (or assets) to explain the obtaining of an income from it or its relative genesis, it is necessary to keep in mind the available theories on capital and income. I will recall some concise propositions drawn, for example, from one of the clearest syntheses of our economic literature; that of Jannaccone (quoted), which has precisely kept in mind Fisher, Smart, Ricci, Alessio, Einaudi, Cannan, Fraser, Cohn Clark, among the economists he recalls regarding:

a) Both physical capital as much as monetary capital (that which I consider in Fisher's example), as well as capital in the multiple forms of rights to an income; they are not only wealth considered in a moment in time, but also wealth considered to be *productive* of another type of wealth (I stress the term for the purpose of the illustration of Fisher's example);

b) Income is wealth that flows to an economic subject over a continuous or finite period of time;

c) Income, in its various forms, is strictly linked to essential economic operations: production, exchange, consumption of wealth. [I need this quote to remember that the economic events that Fisher hypothesises in the case of the three brothers focus on the field of production and exchange (investment, deposit of capital and purchase of annuities in exchange for capital); we are not therefore dealing with consumption of wealth, in spite of the mistaken *apparent evidence* in respect of the third brother, as I will clarify on the basis of the obvious theory.]

capital". If this is "taken in its *true* meaning", that is to say, as (monetary) "profit", whose capitalised value corresponds to the 10,000 units the three brothers started with, then a tax of 10% on the income will collect 50 units from the first brother, nothing from the second brother for the first 14 years and then 100 units after that, and 200 units per annum for six years from the third brother. The burden of the three impositions over the three brothers will be, in these circumstances, exactly *the same*, when the three sums are compared on the basis of their current values. Each brother could discount, at the compounded interest rate, his imposition at an equal cost, that is to say, for 1,000 units, as 10,000 is the current amount that corresponds, respectively, to 50 units payable in perpetuity, to 100 units per year for 14 years from now, and to 200 units per year for six years. There is therefore no violation to

d) When it is a matter of physical or monetary capital, made up of assets that cannot be used for immediate consumption, it is less evident that each capital is considered essentially on the basis of a choice of *several incomes of different entity or different duration* (such are in fact, as we see in Fisher's example, those of the three brothers). In the other cases, the conversion of capital into income ordinarily requires first the transformation of capital into money and then a second transformation of money into assets for immediate consumption. Someone who, for example, sells his land, house or titles for 100,000 units, from which he derives an annual income of 5,000, or who spends the 100,000 units in a single year on clothes, food, travel, shows and other short-term assets, or distributes the expenditure with 50,000 units spent over two years, or 25,000 units over four years, in practice has *replaced a perpetual (nearly) income* of 5,000 per year with an income of 100,000 over one single year, or 50,000 over two, or 25,000 over four, and so on. In the current terminology, such an operation would generally be defined with expressions such as "eat one's capital, living on one's capital, spending one's capital" and similar, which indicate the material destruction of capital rather than its *transformation into income*. However, it is clear that the capital in this case is not materially destroyed but simply transferred from one subject to another and converted from one form into another ... Here again, therefore, the use of any capital is resolved essentially into the choice of a subjective income of a longer duration but smaller entity and another subjective income of shorter duration but greater entity.

e) On the other hand, if the distinction between capital and income is rooted in the concept of *productivity*, the operation of whoever sells his capital assets for 100,000 units and then spends the revenue from the sale on consumption goods over four years, at a rate of 25,000 per annum, does no longer *appear* to be one of *transformation* of capital into income, because the 25,000 units are not the *fruit* of the 100,000 units but a *part* of them; therefore converting the capital sum into consumption goods *appears* to *destroy* the possibility of obtaining an income and therefore to destroy the capital itself. However, the concept of *economic* productivity cannot be identified with that of *physical* productivity, and in any case a sum of money never physically produces anything at all. Deriving a sum of 5,000 per annum from a sum of 100,000 for an indefinite number of years or only for 20 years, deriving 10,000 for 10 years or 25,000 for four: these represent different *uses* to which the sum can be applied, and *if the first sum can be called an income, there is no reason why the others cannot be income too*, unless this concept and this word are reserved only for an income of perpetual duration. There are good reasons to give a marked significance to constant and perpetual income in comparison to incomes of variable and arbitrary extent and duration; however, this should not lead us to the *common delusion* that in the first case there are two distinct entities of wealth, one represented by the capital and the other made up of its fruits, while in the second only the capital exists and this is destroyed by spreading the use of it over a shorter period of time.

These clear and concise statements, the result of a long and close examination and re-elaboration of concepts (hand-picked from pp. 180-258 of the *op. cit.*) help us understand how the incomes derived by Fisher's three brothers are *all*, including that of the third brother, produced with investment or exchange of capital (assets). This can be done without confusion, in the object of the hypothesised levy, between capital and income, in the three cases, going back through a process of capitalisation to the respective homogenous source, and therefore through the separation of economic entities and times, by adopting the preceding definitions.

If an economic subject (such as the third brother in Fisher's example) prefers greater incomes of shorter duration, earning himself the moral qualification (which is not necessary or relevant to the science) of being a "big spender" (Fisher's expression), this does not mean that the achievement of this income is a matter of consumption of income (later time), as excluded by Jannaccone's interpretative criticism with respect to common or vulgar expressions reported above ("eating one's capital", etc.). The same can be said of others who morally qualify the subjects as "having a wider or more narrow economic horizon", "prudent or improvident" (in Demaria, *op. cit.*), with the mentality of an "unmarried" person (in Fasiani's work, *op. cit.*, that defines the subject with preference for short-term incomes) or "a player" (as was discussed in the context of the differentiation of more or less probable incomes of a different entity, in the previous chapter), etc.

Mill's postulate because "a tax on income, applied according to the exact concept of income, would not perturb the comparative merits of these different streams of income": so Fisher expressed himself, denying in fact that in this case there is a double taxation or inequality, despite considering the hypothesis of the direct tax on the income produced or received by the subject, through exchange, as monetary "profit".

When is it then that the American economist is considered, especially by Einaudi and other academics, as the one who demonstrated the truth contained in Mill's quoted passage? When he adopts a ("spurious") definition of income, that in truth I could not endorse¹⁷⁶: when he places as object of the tax not only the income but also the increase in the value of the capital, in other words the source of the income, at the same time.

However the definition already found in my treatment of the matter in these lessons with regard to differentiation, or that which I have adopted here, does not include increases in the value of the capital, and neither did Fisher's "true" definition. There are no violations of the postulate of equality on the basis of this because, it has been seen, elements of *capital* value (variations) were *not* included in the concept of *income*, so there is no contradiction in the type of that declared by Mill when he complains that it might be possible to tax the capital and the income at the same time.

So, to clarify the issue, I recall that Fisher addresses his own criticism to the United States' *general property tax* and not the *income tax* in the same or other countries. That is to say, he rises up against that type of American tax on assets that is measured on the value of capital assets. This tax has been the object of many criticisms (in relation to which I refer the student, for example, to the detailed review of them by A. G. Buehler, in *Public Finance*). It is easy to understand how the tribute Fisher disapproves of violates the postulate of equality, when the traditional example used in all treatises is kept in mind: the one, already mentioned, of the forests. The increase in value accumulated during the period in which the wood has not been harvested is considered as income, as is also, *later*, the income from the wood harvest. Furthermore, in the period before the harvest, there has been no revenue and, in spite of this, an annual tax is applied to the value of the forest. Some suggestions have been put forward to avoid the violation of the postulate that refutes the simultaneous taxation of the accumulated capital and of the income, including the deferment of the property tax until the time the income is realised with the wood harvest; or the reduction of the annual tax on the *value* of the forest to a rate that is equivalent to the property tax measured against net income.

It is in any case interesting to observe that the definition, which contains an implicit contradiction, in particular in the meaning criticised by Mill, because this is a matter of the measure of the collection with regard to the *value* of the property, affects essentially the imposition on *assets* and *not* on *incomes*. In addition, by including elements of capital (increments), it considers a concept that is very different from the one that Fisher himself defined as not "spurious" and that *does not determine a double taxation* or from the ones I have previously expressed.

It needs to be said that the same Einaudi admits that the various taxes that can be hypothesised, and the effects of which we intend to study, must be presumed to "be different one from the other only because one collects the *defined* income in a certain way (my italics) and the other income defined in other ways". He however inevitably admits this after retaining as inadmissible, in pure theory, the presumption that income must be given "that definition or periodicity that this or that investigator prefers". Against everything found in methodological works, some of which have been quoted here and that appear in the *Introduction* of this course, Einaudi states that thinking based on such gratuitous premises does not have any value. Furthermore, the premise (that in his argument is equivalent to a definition) must be demonstrated, with a vision that does not find any support in any of these works. Indeed, it has been specified above in which sense the definition, as the hypothesis, includes in itself typically arbitrary and conventional characteristics – because they are linked to the

¹⁷⁶ Everyone can, in theory, adopt the definition he thinks opportune, as long as he can derive the logical consequences, in the theories or problems in which he uses it. However, for example Seligman in the United States, in a specific close examination ("Nuova Collana di Economisti" [New economists series], Vol. IX), does not recognise as income the earnings derived by increases in the value of capital, if it is not "separated and realised", precisely also using (Fisher's) typical example of the forests. He does not believe that the increase in value of capital is income until the trees have been cut down.

inventiveness of the investigator – of each scientific classification; this is legitimate, even if arbitrary, inventiveness of explicative analyses and does not require any *a priori demonstration* other than that of the non-contradictoriness we have mentioned, *a posteriori*.

Indeed, if I insist on this point it is because, for example, Einaudi rejects the premise of one of Ricci's arguments, based on the imposition of the income produced at different times, against Mill's demonstration of the double taxation of savings and the fruits of savings (p. 46 of *Contributo all'«ottima» imposta [Contribution of the "optimum" tax]*, *op. cit.*).

However this negative position, which clashes with the methodological rules of scientific thought, clearly cannot stand even in Einaudi's argument until about ten years later (in *Miti e Paradossi della giustizia tributaria [Myths and paradoxes of fiscal justice]*, of which I have quoted G. Einaudi's II edition in 1940). Stating that "in front of the court of reason" there is no infallible judge in the choice of premises (I call them definitions), he limits himself to recognising that the premise (which he defines α) exists. Through this, the wealth that in each given time interval flows into the economy of the taxpayer, net of production expenses, in addition to the capital owned by the same taxpayer at the beginning of the same time interval, is defined as taxable income with a tax x (for example 20%, such as the one that figures in the numerical example we will return to) at any time interval (financial year).

The same Einaudi considers as a premise (defined with β) the condition – which on the other hand I have considered as the constraint of non-contradictoriness of the definition of income (that he defines as premise α) – that in the mentioned time interval the taxpayer does not suffer damage greater than any x chosen by the legislator or, generally, hypothesised as collection of a tax on income.

After this essential and in fact decisive clarification of the object of the imposition, according to different definitions that link the solution of the problem, a clarification that I have to make, having made the premise, with an *apparent* petition of principle, that the hypothetical definition has the solution within itself, I return to express more extensively the argument that, incidentally but firmly, I have expressed with respect to the long-lasting controversy on the claimed double taxation of savings.

4) After a brief indication of the points of view, contained in the summary reference of the *sense* in which, for example Mill and Einaudi on the one hand, and De Viti De Marco and Stamp on the other, affirm and deny the double taxation of savings, an indication that appeared in my "Principii di scienza di finanza" [Principles of the science of finance] (Milan, Giuffrè 1939), I expressed the meaning of my concept in 1941.

In a paragraph (no. 7) of an article (titled: E. D'ALBERGO, (*Politica finanziaria, reddito e risparmio nell'economia del dopoguerra [Financial policy, income and savings in the post-war period]*), published in the journal of the Cassa di risparmio delle provincie lombarde [Savings bank of the Lombardy provinces], No. 3 of 1941) I summarised this vision of the controversy, formulating the following conclusive propositions, that presumed, for example, that which appears in the paragraph preceding this chapter. (These propositions were inserted in the previous edition of these lessons, in 1944).

a) I qualified, as an objective *antithesis* of points of view, what derived, without the authors being aware of it, from the multiple reasons put forward, with regard to the unmitigated dispute, by those who support Mill's position and those who deny it.

b) I stated that the supporters of the need to exempt part of the income saved (it would be better to say, after what precedes and will follow, that can be saved) for the purpose of avoiding a *greater* taxation of such quantity, included in the income subject to tax, were perhaps wrong to contrast this point of view, which is legitimate in itself (which is *not* that of the *double* taxation but that of the *greater* taxation) to those premises on which the imposition of the produced income is based.

c) I considered *parallel* and not necessarily opposite points of view to be those from which a tributary system can be built, on the logical bases respectively of premise A) of the income consumed, as object of the imposition, such as it was that considered by the Mill–Fisher–Einaudi triad. Alternatively it is possible to start, again logically, from premise B), that each event of production of

income, in the wider sense, as such (which means, because the income is *defined* with reference to such an economic “moment”), irrespective of its subsequent destination, must be subject to direct tax.

d) Finally – and the observation seems to be very important for the autonomy of the concept – I placed *among the many ways* to support the premise B) the original construction of De Viti De Marco, in the sense that at any period in *time*, when production events take place, in respect of which the function of the State is instrumental, as is that of other productive factors, the credit of the State for the tax on the produced income becomes due.

Of course I concluded a detailed demonstration worthwhile, in another context: the expression of the coexistence of parallel, and nevertheless logical from their respective points of view, criteria and presumptions.

This theoretical position, linked to the apparently paradoxical vision proposed to students (in the terms referred to above: “the solution is included in the definition of the object of the imposition”), has not gone unobserved. Gangemi, the careful academic, sensitive to the novelties and the divergences of opinion, noted in the quoted *Elementi di scienza delle finanze [Elements of the science of finance]* (p. 488): “As d’Albergo precisely observed in considering the reasons adopted by the supporters of the two theories, we find ourselves facing a coexistence of criteria and presumptions”; he highlighted the following words in the sense that they are “parallel and nevertheless logical from their respective points of view”.

However, already before this time, the vision I expressed first in person to Fasiani (Congress on the problems of autarchy in 1940, in Milan) and then included schematically in the quoted publication in 1941, had the effect of persuading that fine mind to reconsider the theme considered before, with the unilateral conclusion of the re-affirmation of Mill’s position and, in particular, that of Einaudi, his mentor in the scientific field. Villani must have overlooked this anecdotal clarification, that I made on the occasion of a brief obituary for Fasiani (“Rivista Bancaria” [Banking Journal], October–November 1950), in the vivid reintroduction of the evolution of the late academic’s thinking, writing that “Fasiani, while in his writings on the same subjects, follows essentially the traces of Mill and Einaudi, and he strangely recognises as logic the conclusion of De Viti De Marco”. Indeed, the subject re-discussed with Fasiani (quote from the “Banking Journal”) “gave the opportunity to the writer to formulate this question, with what the late Amico defined as the *disconcerting* alacrity that is typical of the man of the South: that is to say, whether he had asked himself if the solution to the problem was not in the hypothesis itself, in the sense that what is presumed to be logical in an initial assumption (equal taxation of two produced incomes of the same sum) is not (equal) every time that the presumption (production) occurs or is hypothesised, over time. So, the coherent effect of such a type of tax is something very different from the claimed *defect* identified by Mill onwards, by some (Einaudi to start, in Italy) in the system of direct imposition in produced incomes. Fasiani’s attention suddenly addressed this mode of seeing the problem, which, *in different terms* from those according to which I think, was mainly that of De Viti De Marco: from this came Appendix VII of the *Principii di scienza delle finanze [Principles of the science of finance]*, lessons in which Fasiani, in an enlightened way with regards to the scientific honesty he demonstrated to students and readers, candidly confessed not to have read with sufficient attention (he had not “given to it, on other occasions, all the import it deserves”) the criticism masterly expressed by De Viti De Marco. Given the premises, De Viti’s theory appeared to him to be exemplary.

[Another anecdote in the context of lessons (and not of treatise) needs to be recalled for readers and in particular students. A degree thesis was being discussed at the University of Bologna. A valiant economist, mentioned in paragraph 2) was present. The thesis was connected to Mill’s vision of the double taxation of savings. To the illustrious interlocutor, the exemption of a part of the saved income appeared to be dictated by the need to comply with the postulate of equality. I thought of asking *which equality* he intended to be discussed. And the controversy came to a sudden end, because it is an easy intuition to recognise that there is equality (I) in the imposition of the income defined as consumed, and (II) in the imposition of the income defined as produced or received or streamed into the hands of the taxpayers compared with the opposing economic events (I and II). However, it is not possible to criticise *one* of the two criteria of distribution of taxes starting from the definition and using the argumentations that explain the logic of the other.]

In any case, as I have recalled, the same Einaudi admitted the logic legitimacy of different hypothetical definitions not necessarily corresponding to the empirical ones that implicitly, in different legislations, define the object of the taxes considered or of different systems (α and β). My interpretation of Fisher, of the first manner (1906) of thought with regard to this, indicated that there is a concept or definition of income or “profit” obtained from the investment of capital that makes the positions of the receivers (the three brothers) equal with regard to the tax. Furthermore, around 30 years later, the same illustrious American economist expressed his concept better, improving on his first expression. To call into question the statement of one of our masters, Jannaccone, who clearly highlighted the transformation of income into savings and capital in his *Nozioni preliminari di economia politica [Preliminary notions of political economy]*, *op. cit.*, I recall his view with regard to Fisher’s evaluation of the conceptual evolution or conversion¹⁷⁷. He “had” persistently supported the exclusion of savings from income but ended up admitting that goods destined to become converted into capital are part of the income, before the transformation is completed. He therefore proposes the differentiation of income *before* savings from income *after* savings: this is the same as differentiating, concludes Jannaccone, “total *produced* or acquired income from *consumed* income, which is one of its part and the last of its transformations” (p. 249). Fisher subsequently (1939) reconfirmed these positions.

These are now widespread in the United States: I recall, for all finance experts, Taylor (*op. cit.* pp. 397-401) with the following summary propositions:

- The point (or moment) in which the monetary income should be measured is that in which it comes into the hands of the beneficiary, that is to say, when it becomes available to be destined for consumption or for savings. Indeed it must be presumed that the disposal of income follows the principle of “maximisation” of satisfactions, whether income is destined for consumption or for savings.

- If the income is defined in its strict sense, as enjoyment derived only from consumption, then savings are not income, and the monetary income must be measured *after* it is divided into the flow of consumption or the flow of savings.

- If income is defined in a wide sense, so as to include in it all the satisfactions available with monetary income (after the deduction of their cost of production), it is measured *before* it is disposed of, and savings are income.

- From the tributary point of view, there is discrimination against savings if the part of income that is destined for savings is taxed before it is saved and after, again, when it is *spent*.

- From the theoretical point of view there are elementary aspects of justice (in our sense, of equality) when the position of two people is considered: with the same net income, before the income is disposed of and in the same personal position, they have the same contributive capacity.

- Defining income for tributary purposes, such as income received before it is available for consumption and savings, we measure the tax against those means destined to become a part of the capital of the subject. However, to say that this is imposition on the capital is to deny that capital is created with income; that is to say, savings are derived from income.

- The tax on income is not intended to be paid with capital: it is necessary to avoid portions of capital being considered income, and this is achieved by excluding reserves for the depreciation of capital or its devaluation and destruction. In this sense, paraphrasing Hicks, Taylor finds the definition that emerges from what has been said in this chapter, with regard to income produced and received before it can be disposed of¹⁷⁸: monetary income in a given period is that part of gross income that can be used without preventing the prospect of an equivalent gross income, for each successive, analogous period.

I think this statement (drawn from current North American literature, 1948) is most likely influenced also by Fisher; I also think that his criticism is appropriate enough to reinforce one of the opinions that, independently, had for some time been part of my vision of the problem.

¹⁷⁷ *Income in Theory and income taxation in practice*, in “Econometrica”, January 1937.

¹⁷⁸ For savings or for consumption, and drawn from *individual* sources of income, without proceeding to the synthesis of available = enjoyable typical of the object of personal imposition.

II.

*HETEROGENEITY OF THE TWO SYSTEMS OF TAXATION: A) OF CONSUMED
 INCOME, B) OF PRODUCED INCOME.*

1) The long logical premise, contained in the previous paragraphs, allows us to proceed quickly in commenting on the numerical example in the first one, a shortened shifting of the Mill-type thesis, and in remembering some points of view that permit us to overcome the criticism in the thesis itself aimed at the system of taxation of produced or received income, *before* it is available for consumption or saving.

This numerical example needs to be considered while keeping in mind my apparently paradoxical statement, that the solution of the problem of equality is in the hypothetical definition of the object of the imposition. And since the definition must be reconciled with Mill's postulate, which requires that income and capital are not charged *simultaneously*, it is necessary to demonstrate, for example, that the sum of 64, which would represent a reduction of the capital of 80, because of the double impact of the tax on income (100 - 20%), after a first period of time, and of the tax on the revenue from 80 (4 - 20%), does not occur in the market, capitalising the income net of the tax.

A) As the incomes of 100 of the two hypothesised taxpayers have not come about out of thin air, let's presume that they are the result of a previous productive process. Let's presume that Tom and Jerry, taxpayers, have obtained, in a *first* period of *time*, a gross income, respectively, of 116 from a capital of 1,600 units. 16 of these 116 are allocated to maintaining the economic value of the capital unchanged, and 100 remunerate the capital, gross before a 20% tax. The net income of 80 units, the residue after taxation, at the market capitalisation rate of 5% leaves the capital invested unchanged, at a value of 1,600 units.

That is to say, in addition to finding room in the gross income for a sum for amortization, according to the adopted definition of produced income, it is necessary to implement adaptations and "re-adjustments", detailed analyses by the same Einaudi¹⁷⁹, due to the expectation of the application of the tax of 20% on the income. Therefore, in the hypothesis, an *increase in the cost of the use of savings* occurs, *due* to its dissipation caused by the forecasted tax, and a temporary *increase in the cost of the instrumental goods*.

The same set of adjustments, in expectation of the tax of 20%, to be paid at the end of the *period of time* (II), which is a hypothetical "production period", must be extended to the process regarding the transformation of the residual income (100 - 20) in savings, with the function of capital employed in the period in question (II). Redoing the calculation, 80 units will produce, gross of the amortization or devaluation rate, 5.80 units (of which 0.80, or 1%, for the reintegration of the economic devaluation rate and for the forecasted tax of 20% on the residual income). This is the same as saying that the return of 4 units, with respect to the 80 that figure in the example in the first paragraph of this chapter, are net of the tax (20% on 5 units). This allows us to calculate that these 4 units, capitalised at the market interest rate that is presumed to be unchanged, signify a capital value of 80. Therefore there is no double impact, simultaneously, on the income and on the capital and this remains unchanged at 80 units, without the contradiction of the example used by supporters of the double taxation of savings taking place. Indeed 80 is never the same as 64; and 4 units of income are not gross of the tax, as they are reduced to 3.20 after the claimed collection of 20% on 4.

That is to say, that the market does admit the existence of values of 80 and 64 only because of the adoption of the system of taxation of produced and received income is adopted *before* it is apportioned to savings or consumption.

The equality, conceived by me in the sense that incomes that are equally *defined* should bear equal taxes, is realised without implication in the definition of the *contradiction* claimed by Mill, when he suggests that the system in question gives rise to simultaneous imposition of capital and income.

¹⁷⁹ "Ottima imposta" [*Optimum levy*], *op. cit.*, even if not endorsing the general conclusions drawn.

Therefore it can be said that equality is realised when the following proportion is applied, *in time*, to *all* taxpayers:

$$\frac{P_n - t}{C} = \frac{p_n - t}{c}$$

where:

P_n - is the produced income, decreased by the capital economic amortization or devaluation (in the example, 100);

C - is the capital (1,600) from which an income (of 100) is obtained, gross of the tax due for the *first period of time*;

p_n - is the income defined as above, referred to a capital of 80 (5, in the example);

c - is the capital of 80, from which an income of 5, gross of the tax, is obtained in a *second period of time*;

t - is the tax (20%, i.e. 1/5, applied respectively to 100 and 5).

In this thinking *the interest rate* of 5% on the market, as rate of capitalisation of net incomes, is presumed as *unchanged*.

In this obvious conclusion, which, as Einaudi would have it, can be defined as “thinking in circles” to deny its inevitable truth, or petition of principle, to try and shed doubt on the logic that is intrinsic in the adoption of the criterion of taxation of net produced or received income available before its apportionment to savings (and subsequent investment) or to consumption, there is no duplication of the object or contradiction of Mill’s meaning. In fact no capital quote (dp) is included in the object because, according to the definition in these pages, the part (dp) that is destined for the re-evaluation of capitals that are here presumed to be material and expressed in monetary value, is not considered to be part of taxable income. Similarly therefore there is no contradiction, which Mill rightly wanted to avoid, in the double incidence of the tribute, on the capital and on the income. That is to say, the same quantity of wealth, capital and income (interest) are not part, *simultaneously*, of the taxable income of taxpayers compared *according to the definition*.

B) This argument could be repeated presuming that, in the two periods (I and II), the capital, respectively 1,600 and its 80 units, produces a 5% return, net of the amortization or economic devaluation quotes. The income net of the tax would be, in the *two* cases, for the two taxpayers considered, 64 and 3.20, having deducted 20% (with the tax). This would appear to work with the reconsideration of the numerical data of the example that precedes the theory of double taxation in paragraph I (No. 2). However, the same Einaudi (albeit in a doubtful form), Ricci, Loria, Masci and also others admit that the *interest rate* for the capitalisation of the market *could decrease* and for some it could fall from 5% to 4%, leading to capital values, on the basis of respective net incomes of 64 and 3.20 to 1,600 and 80. This second criterion has given rise to discussions in respect of which I refer the reader to the quoted sources and in particular to “*Ottima imposta*” [*Optimum tax*]¹⁸⁰, which did not appear to me to be very relevant as a demonstration, if Einaudi’s well-known and significant argumentations (*Osservazioni critiche intorno alla teoria dell’ammortamento dell’imposta* [*Critical observations regarding the theory of the amortization of the tax*], [*Accademia delle scienze* [*Academy of sciences*], Turin, 1918-19), which he applies in order to demonstrate the admissibility of the *possible* decrease of the rate of interest, following the tax, are disregarded.

2) Logically, *two* events of production of new wealth or income figure in scheme A), in the *two periods* in which it is presumed that *transformations* of (saved) income into capital *have taken place*, as well as increases in wealth or income in the hypothetical periods of production. In other words, thinking about gross incomes t , 100 with respect to 1,600 and 5 with respect to 80 at the end of the respective periods, represent *additional* quantities; it is therefore possible to imagine the *sum* of $C + P_n - t$ and of $c + p_n - t$ at the end of the respective periods ($T_0 - T_I$) and ($T_I - T_{II}$). In this way, taxing

¹⁸⁰ For the bibliography, I refer the reader not only to Gangemi but also to Fasiani (1952 edition) and Villani (Rivista di Politica Economica [Political economy journal], Vol. III, 1952).

200 with 20% does not create the intention to charge *also* or simultaneously the 1,600 (irrespective of the known phenomena of amortization of the new tax); the same can be said of the lack of double taxation of 5 and 80 that is not apparent from the example, on the basis of the *equality of treatment* of the events of production and perception of net incomes, that was intended to be stated.

On the other hand, Einaudi believes that we are faced with “the miracle of the multiplication of loaves and fishes”. He does not believe that to tax 100 and then 5, and 5 and 5 ad infinitum means taxing different incomes “because a series of incomes of 5 units per annum, ad infinitum, is equivalent, at a discount rate of 5%, on which there is absolutely no doubt, to 100 units at present” (*Miti e Paradossi [Myths and paradoxes]*, *op. cit.*, p. 105). According to Einaudi, it is an error “to think that the interest is profit, an addition to the capital, as it is simply a mode of levelling current and future goods, current and past assets” (“*Ottima imposta*” [*Optimum tax*], *op. cit.*, p. 151). “The quantity 100” – he wrote – “at the start of the year, at an interest rate of 5%, is *equal* [my italics] to the quantity of 105 at the end of the year. If the two quantities are the same, one cannot be, even though it appears to be numerically higher, greater than the other”.

To this, already in 1930, Gobbi responded (in writings in memory of G. Prato, at the initiative of the Higher Institute of Economic Sciences of Turin): *a*) that it is not correct to say that 100 and 105 (or 103 in his example) respectively now and at the end of one year, “are economically *equivalent*”. 100 is the value of the 105 available one year since, if there is someone who is prepared to *add* 5 units to the account of whoever deposits 100 (in the savings bank). To say, at any given time, that the value of 105 due in one year’s time is 100, means that we expect that, in one year’s time, 5 will be added to 100. Choosing a future sum if the interest rate is positive means taking advantage of circumstances that allow one to *increase* one’s wealth. Many are content to delay the gratification of 100 now to obtain 105 (or 106) in one year’s time, “because 105 is *more* than 100, *not* because it is the *same*”. (It would appear that Einaudi had taken account of these observations in *Miti e Paradossi [Myths and paradoxes]*, p. 103, 1940 edition).

To Einaudi, who admitted (“*Ottima imposta*” [*Optimum tax*], *op. cit.*, p. 119), that “it is difficult to persuade oneself that the use of an interest rate *does not create a new income*, but it is a simple method to conciliate values existing at different times” E.U. Ricci – in addition to Gobbi – responded:

a) 1) first of all correcting the expression, that is not the rate but the interest that is “a slice of the net product”; 2) when talking of net product, it is essential to fix the time period; and, as the product referring to an instant does not make sense, generally it is best to refer to a duration of one year, also for the net product (as to income, for individuals). Imagine that the production process is repeated ad infinitum: I say that a capital of 100 will give me many sums of 5 units, in a successions of years. The *actual* value of these various quotes is respectively 4.76, 4.53, 4.31, ... and the sum of the series is, as we know, equal to 100. But the capital of 100 does not contain *now* the 5 units that will exist only at the end of the year, when all the addends will have increased a little and the sum of the increases of *all* the addends, for the entire year, will be equal to 5. At the start of the year the capital of 100, compared to a succession of annual incomes of 5 each (a succession of delayed annuities of 5) can be replaced by the sum:

$$4.76 + 4.53 + 4.31 + \dots = 100 - \text{[I]}$$

At the end of the year, each one of these quotes is increased. And it has increased exactly according to the law that follows: the first figure (4.76) has become equal to 5, and each of the others has taken the place of that before, as follows:

$$5 + (4.76 + 4.53 + 4.31, + \dots) = 5 + 100 - \text{[II]}$$

b) We now have the new product. At the end of the year the owner of the old capital of 100 owns the value of 105; that is to say, he can really say that he has earned an *excess*, a net product

equal to 5 and at the same time he still has the original capital of 100 *available*. (See “Financial and corporate studies Journal”, 1942).

While what was presented was easy to grasp, nevertheless the reference to the significant points of Einaudi’s opinion of two critics is helpful in correcting the thinking of this academic. After admitting that Jerry, who in year I earned 100 units and saves them, and in year II earns the interest of 5 units, and now owns 105 units, he also admits that the sum of $100 + 5$ is logical if referring to year II, as it is made up of two quantities, 100 and 5. He, however, denies that, taxing 100 and then 5, all and *only* income is taxed.

The previous presentation confirms that 100, before being transformed into a producing capital of 5, was the income from 1,600 (gross of 20% tax), as 5 was the income from 100, at the end of two periods, and 80 from 16.00 and 4 from 80, after the tax; and that charging a tax first on 100 (income at the end of period I) and then to the income or new wealth from 5 at the end of period II, as quantities produced and available before their transformation into savings, only income is charged. This is so if care is taken to define so as to exclude from it any quantity of capital, as it was done above.

In any case, the result is that all taxpayers who receive produced net income and are charged this type of direct imposition, are the objects of *equal treatment*, in compliance with the postulate of equality. Clearly they cannot have, with this system, 100 at the end of period I and 5 at the end of period II. However, the curtailment of the produced and received income, available for saving (or consumption), before it has been transformed in the use of the residual 80 units (of the example), limits precisely to this amount the function of capital that the 80 units have in the *second period*. From this we therefore obtain the reduction to 4 of the *new* produced and available income at the end of period II.

3) Up to now we have argued on the basis of the content of letters *a–c* of point 4) of the preceding paragraph I, which concisely sums up my position, expressed on the matter at the time. However, De Viti De Marco’s construction supported the logical legitimacy of the periodical, hypothetical direct imposition of income as product. I refer the reader to it (Chapter XV of the *Principii [Principles]*, *op. cit.*) to avoid quoting and spoiling, in summing up, the effectiveness and harmonic coherence of his argument. I will limit myself to saying that it pivots on the demonstration of the existence of two productive cycles: 1) the one in which the income was produced *later* presumed to be having been saved; 2) and the second in which the interest that is the new income is produced (in Mill’s example). However, De Viti accompanies this demonstration (which, even though it is personal, is based on an intuition that can be widespread, in the experts’ opinion) with another, particular admirable one: that of the accrual of State credit, in respect of the new production taking place in given periods of time, using public services as raw materials and human work. “The position of the State does not differ, in the case in question, from that of the worker or any other production agent”¹⁸¹. From this derives the imposition which is renewed, without giving rise to what A. Cabiati considered the *misunderstanding* of the double taxation of savings (in introducing De Viti’s *Principii [Principles]* to readers of the “Giornale degli Economisti” [Economist Journal], 1928). Ricci also admitted that the State collects *its* share of contribution to common production from incomes produced in successive periods.

¹⁸¹ Fasiani formulated the hypothesis that De Viti’s premise fails. However, it is necessary to advise that, even if this were to be admitted, double taxation would not be acceptable in light of what precedes in these pages and it is not a necessary linked to De Viti’s explanation. Furthermore, the explanation of De Viti does not lack value, even in the case of real events, when the fact that the State participates in collective production of wealth and wellbeing or improvement with public services (even Einaudi recognises the atypical instrumentality of these), when it is considered that the State activity produces *utility*, whether private individuals produce or consume their own income. Fasiani (“Giornale degli Economisti” [Economist Journal], 1942) did not recognise this when he compared facts to De Viti’s abstract vision, which is very general and comprehensive with regard to the contribution, even indirect, to production on the part of the State.

4) Einaudi seems concerned with the fact that, when the fascinating theory of the double taxation of savings fails, the *inventiveness* of the vision might be lost, as this vision would help to give a rational explanation of the numerous cases of *exemption* of savings found in different positive legislations, which he lists (mainly in *Miti e Paradossi [Myths and paradoxes]*, *op. cit.*). In Einaudi's view, these exemptions are dictated essentially by the lack of a taxable income, in light of the theory he has long supported. On the other hand (leaving aside what was covered in the previous chapter of these lessons, on the differentiation of taxable incomes), visions of the type of that which we have defined as "financial policy" in the dedicated chapter of the *Introduction* to this course, apply each time.

In any case, for all those who are not persuaded of the sense of the explicative inventiveness (of real, legislative and trend cases of the exemption of savings) of the theory, as Einaudi intends, I will quote Borgatta. His literal fidelity to his master's theoretical vision, expressed with the concise reproduction of the arguments used by Einaudi to support the double taxation of savings as deriving from the taxation of "earned" income, fails where (pp. 197-99 of the *Appunti [Notes]*, *op. cit.* 1933) Borgatta interprets the historical trend of the tributary system to exempt savings. Various measures of this type are qualified by the author, who nevertheless abides by Mill's vision, as having been "adopted by legislators for reasons other than the concern to avoid the double taxation of savings".

In the expression of Borgatta, indicative and significant author, falls what might be the main (perhaps) reason why Einaudi did insist in the unsustainable demonstration of the so-called Stuart Mill theorem, even though he did so with great richness of expression.

5) After what precedes with regard to the illustration in these pages of the coherence of the definition of produced and received taxable income at a time when it is still available for consumption or transformation into savings, and of the inventiveness of the definition for the ideal construction of an abstract system, that is to say, compatible with the postulate of equality of the imposition, I will save the reader from the obvious demonstration that could be carried out in the same sense, assuming as object of the imposition only consumed income, equally charged in different subjects-taxpayers. That is to say, I will trust the reader to easily realise the logical development of the content of my statement, included in point *c*) of the propositions on the subject (at the start of point 4 of the previous paragraph).

A comparison is irrelevant because it would be irrational when we make claims to criticise the *effects* of one in the same way as the different *effects* of the other: that is to say, the comparison between what happens in the field of imposition of produced and received income available for savings or consumption, and that which would be a different and parallel – but not comparable because heterogeneous – taxation system that assumes as object the income actually consumed, irrespective of the equality of the respective imposition.

6) In the presentation of the ideas that I have developed for some time with regard to this, already succinctly mentioned earlier, the reasons to dispute, from the point of view from which this title takes its name, vis-à-vis the central problem of the "mode" of distributing tributes, appear to be essentially non-existent, in the logical field. If the use of geometrical representation were to be permissible, it could be said that the two systems, *A*) and *B*), the first relating to the taxation of consumed income and the other to the taxation of produced income, would be two parallels, where a point of contact between them *could not* exist other than in infinity.

Therefore equality – as postulate that dominates the solution of the problem of the modes to distribute tributes, in any type of State and market conditions – needs to be seen *not* in the sense of relating the effects of the two processes, compared with a common *intersection* line, but it needs to proceed along *parallel lines*, automatically, comparing the positions of the taxpayers subject to taxation according to each system, with the exclusion of the double taxation.

If this analogy of visions is permissible, let's observe that the two systems, in the long term, in the indefinite succession of periods of time (i.e. as a trend for the precalculated periods of time) for the two parallel lines, end up having the *same object*, if we consider the decisions of the taxpayers as producers, savers and consumers, or the decisions of State political financial art policy.

In this controversial theory there is no thinking of two modes along, I believe, parallel lines, of distributing the tax, *in terms of parity of collection* for the State. Indeed, *sub b*), in the just quoted point 4), I admit that the assumption of produced and received income and available (for savings or consumption), as object of imposition, provides a *greater taxable matter*. This is why, at parity of tax rates, the instantaneous revenue is greater *generally* if the income so defined is taxed, rather than on the basis of income consumed by individual taxpayers.

Therefore, from the point of view of the State, it is indifferent to charge a produced income of 100,000 with a 10% tax, or to charge only the consumed income of 50,000 with a 20% tax. Obviously this leads, at the *time* the alternative is suggested, to the same fiscal revenue.

However, the two systems, of which we have highlighted the autonomy and parallel adherence to the postulate of equality of imposition, offer the possibility of an *equal* revenue, at parity of tax rates and *parity of objects*, as *quantity* of income *definitely taxed over time*; however, the revenue is *deferred* when consumed income is taxed. Therefore an equal but *not equivalent* revenue is obtained, because equal quantities are available in different time conditions.

After revealing his own negative criticism towards the claimed double imposition of savings, J. Stamp writes: "Let's presume that an individual saves 100 units and at the end of ten years he has obtained 5 units per year. As he still has the 100 units, he now spends them. He pays a tax on 150 units in total, according to the current system, with a tax on 100 units in a first place and then, with regard to the 50 units of the annual return, an alternative system of taxes on expenditure applies, which he pays yearly for 5 units per year and then on 100 units on the tenth year. In both cases he pays for 50 units more than he would have done if he had spent the 100 units in the first year". (It would appear not to be correct to call this process "double taxation", Stamp concludes. In the meantime he has demonstrated that, assuming a given period of time, with an average behaviour of typical subjects, a parity of taxable income as quantity in object is obtained).

Generalising, after having given other numerical examples, from which it appears that the different hypothetical distribution of "earned" and consumed income amounts to the same, over time, U. Ricci concluded that the diversity of the two systems of taxation consists, *for the State*, in receiving a tax ("earned" income as taxable sub) earlier, while with the other system (consumed income), it would receive it at the end of the period in consideration (in the example given, 4 years). The generalisation consists in saying that "the tax applied to *earned* income is paid gradually as savings start and are then incorporated in the capital that will then become a consumption asset; and also as interests mature and similarly are incorporated in the same capital".

The tax applied on *consumed* income is paid on the consumption goods, which is a transformation of the instrumental asset. Therefore *the total amount of the tax does not change*, but the payment of it is *deferred*. "This does not mean, of course, denying the difference of time implies difference in value, but it is simply a clarification of the economic effect of taxation of savings" ("Studi economici finanziari e corporativi" [Financial and corporative economic studies], *op. cit.*, Nov-Dec, 1942).

CHAPTER VIII

THE PROCESS OF “PURGING” OF ECONOMIC QUANTITIES FOR THEIR REDUCTION TO TAXABLE QUANTITIES

I.

THE PURGING OF TAXABLE QUANTITIES IN THE HYPOTHESIS OF TAXATION OF INCOME: 1) THE PRODUCT, 2) TOTAL AVAILABLE INCOME, 3) CONSUMED INCOME, OR FROM ASSETS.

In traditional treatises, the process of purging is viewed in the context of *technical* modalities through which the “base” or the object of the imposition is determined, keeping in mind as usual the most frequent cases of taxation of income.

It is necessary, however, to warn that the technical procedure conceals problems of economic *logic* converging on the field of the theory of public finance and which relate, according to the definition of the discipline, to the “modes” of distribution of the cost of indivisible public services in the strict sense.

In fact, to specify the *object* of the imposition, it is necessary to define it. Having coherently admitted such a definition, it must be taken into account both in abstract argumentations and in terms of making the defined concept correspond to the facts that it is intended to explain, adhering to the criteria of *equality*, for example, if the justice that politicians require as a guiding principle for legislators in this field is to be translated in terms of equal position of quantities and subjects with respect to the fiscal collection.

The object of the imposition is normally wealth in the form of: *α*) income or monetary flow, or a series of services deriving from a single source; *β*) sum of incomes, at a given *moment*, in the temporal and logical sense of the expression; *γ*) or *capital* value (or assets, as they are mainly defined in the legislation of various States), corresponding to income considered as in *α*) and *β*).

However, indicating the *species* of *income*, it is necessary to specify if it is the intention to choose the subject of the imposition in the hypotheses or in fact: 1) net income produced and received from individual sources; 2) net total available income; 3) total available income. Similarly it can be conceived as (*a*) an individual capital-based income or (*b*) total assets, owned or transferred, considering the *capital* as the object of the imposition. In both cases it is intended to refer to the net value of wealth in the species of *fund* of values (as opposed to flow or income).

When considering the qualitative differentiation of taxable objects, mainly as incomes, the definition of net income was incidentally given, in the sense that this quantity results from subtracting (from gross income) the expenses and burdens needed to be met to produce income. Expenses therefore are considered quantities to be deducted as causal and economic prerequisites of the production of income. As for production it is necessary to use instrumental (capital) goods; to have a net income it is necessary to deduct (from the gross income) the expenses necessary also to the conservation and renewal of instrumental (capital) goods; in a static vision these represent the amortization rates for employed capital.

Furthermore, the (according to some, “earned”) income is defined as the amount of wealth formed during a given period of time and that is available to its owner for the purpose of consumption so that, after consumption, the capital remains unchanged. This means that it is necessary to put aside proportions of gross income for the depreciation of the capital employed, for the purpose of leaving its value unchanged.

1) The purging in case I) indicated above is a process that needs to be considered in the same logical way whether it hypothesises the *production* of incomes in itself, regardless of the subject having the perception of the income from *individual sources*, or whether it considers the subjective moment of the *perception* of income, from individual sources, on the part of subjects in whose favour this is produced. In both hypotheses the *subsequent* destination of the net income is disregarded, whether it goes to consumption or, in part, to savings.

The process of purging is made more complex if it hypothesises as object of the imposition the overall *available* income, deriving from all sources, in the hands of physical persons. In this case the category of available income requires deductions of quotes that, at similar levels of overall monetary incomes presumably already net of expenses and burdens incurred for their production, are assumed to make differently available the overall incomes in function of given subjective conditions of the physical persons and of their “species”, which modify the enjoyability or availability of the overall income.

By definition, it is a matter of admission of minimal proportions for the existence of physical persons and the persons for whose existence they need to make minimal quotes available (dependent persons), or proportions for savings recognised by the law or of interest on debts. These are deductions that, as we can see, logically concern the field of quantitative differentiation (as there is no reference to the nature of the income) but that coherently derive from the hypothesis of a taxable object defined as a synthesis or complex of net incomes available to physical persons or similar consumption units (families), after purging of these proportions for the need of *equality*. This is so because the availability, variously influenced at the time of assessment by the *different* specific already mentioned conditions of the taxed subjects, also needs to be compared.

Some of the elements common to hypothesis 1) of produced income and 2) of overall available income, are nevertheless also common to the two cases to which the respective institutions of the *real* and *personal* imposition correspond, but in different forms and quantities. The deduction of a proportion of *net* income leads out of the field of purging, and in terms of exemption it could be considered to be only dictated, including in the case of real taxes, by the presumption of a minimum for existence; this leads us, however, to the conception of available income for vital enjoyment. [As has been seen in the note that follows the chapter on differentiation, the legislator, in particular the Italian one, with the institution of allowances in the context of taxes on incomes produced and received by individual sources, has introduced the credible criterion of the minimum for life *outside the rational context*: furthermore this is a concept that presumes the synthesis of the economic conditions of the person (or of the family) and that is deceptive in the case of the object of the individual, real imposition. This is felt to be an incorrect solution because, as I have already mentioned, a collection of incomes is envisaged, partially, to introduce the institution of the allowance of exemption].

Normally the minimum of exemption in real taxes are explained by technical and administrative reasons, irrelevant from the point of view of the vital minimum [which rationally occurs in the personal imposition that, in a logical context, takes into account, precisely, the overall available income as a sum of incomes already purged and net]. Indeed the States continue to refuse to bear the cost of verification and collection of incomes of small extents.

Some people have insisted on a purging deduction in the exemption of a small income for some categories of income in which the factor of work plays a part; that is to say, some people have insisted on explaining it in the light of purging, in a manner analogous to what has been said here with regard to deduction (amortization) of a proportion of *gross* income for the purpose of maintaining unchanged the value of capital or instrumental goods employed for the production of produced income.

However the comparison in the context of purging real and personal taxes in the light of the differentiation of the taxable object in net incomes from individual sources and overall available income is more precise with regard to the deduction of sums relating to interest on debts: these, for example in Italian legislation, are admitted as deductions from gross income to obtain net income, as borrowed capitals represent an economic prerequisite for the production of income, and in a limited way for borrowed capitals that have such a determining function in the productive process also in the case of *real* imposition. On the other hand, in *personal* imposition interest on debts are deducted from the total incomes subject to taxation, whatever the reason for incurring the debt for capitals (but only if the creditor is identified).

In the personal tax there is no limitation to the admissible deduction of interest on loans from the State because there is no requirement for an economic link or relevance of these with individual

events of production; however, the degree of disablement in terms of availability of overall income in the hands of the physical person, also due to interest on debts, needs to be assessed.

2) The object of the imposition can be – also and simultaneously with hypothesis I) – the expense of income, in individual or separate items of consumption in a coordinated system of individual taxes, or as object of general taxation of all expenditure: in this case the deduction of saved income, from the object subject to tax, is automatic (see: E. D'ALBERGO: *La crisi dell'imposta personale sul reddito [The crisis of the personal tax on income]*, Cedam, Padua, 1931).

3) Lastly, as has been seen in the note in the appendix to the previous chapter, and in letter γ) in this paragraph, the *capital* or *net* asset can be chosen in advance as the normal object of the imposition or as object of extraordinary taxation. (See the chapter on extraordinary finance).

However, for capital or assets as well, whether it is considered in individual forms or overall, it is necessary to proceed to the deduction of duties and liabilities, which represent the rights of third parties to collect or to demand (credits) proportions of them, from the economic value to arrive to the net, taxable value.

It is not a matter, as can be seen, simply of a *technical* procedure but of choice, in the hypothesis and in fact, of *modes* of taxation to which it is necessary to comply coherently in arguing the logical and economic consequences of the hypothesis being studied or of the concrete choice in the historical and legislative context with regard to the object of imposition.

II.

LOGICAL FOUNDATION OF THE PURGING PROCESS OF TAXABLE OBJECTS.

It is possible to make any hypothesis with regard to the taxable object and admit any definition; however, the condition of scientific coherence is that the same definition or concept applies to all homogeneous events or for all subjects to which the defined entities (produced, perceived, available, consumed income, etc.) are connected. In other words, if the equality of the imposition, for example, is the vision that shapes a tax system, it is necessary that all facts and subjects homogeneously definitive are equally considered. The process of purging of incomes and assets also aims towards this purpose of justice in *equality*, as I will explain later.

By referring all facts and subjects that logically allow it to the definitions of objects of taxes, alternatively or independently hypothesised or historically chosen, it is not possible to imagine that a different treatment of the taxable object is achieved, in other words, that there might be discriminations for or against determined taxed quantities.

With these words I intend to deny, as I have already done in Chapter VII, the critical presumption of the tax system, for example on *net* produced income, *before* it is destined to savings or consumption, when other people ascribe differentiation to this system against the part of saved income only because it can still produce income at *another point in history* (dynamic hypothesis) by providing, once again, in the form of produced income, a new and logical reason for imposition. As has been seen, there is no so-called double taxation of saved income, in the hypothesis of net produced income as taxable object.

It is something else to state that, through the process of purging that separates from gross income proportions to pay for its production, a *double taxation* of the *same produced income* is avoided, as the expenses met by the subject for production are incomes of other factors or subjects that have contributed, in combination, to the production of the income. There would a double taxation if deductions of expenses and duties were not made, because the same quantity, as produced (gross income) would be subject to the imposition both in the case of the subject that has obtained all the gross produced income and for the subjects for whom the expenses of the first represent an income, taxable separately, as net.

To highlight the logic and theorematic content of purging, which is normally considered an accounting technical process, it is possible to briefly paraphrase Mills' equality expression, according to which "two equal incomes must bear equal taxes" and that I have modified (Chapter VII) in the sense of *incomes equally defined*.

One of the interpretations of this formula has already been applied in the context of qualitative differentiation, by referring equality to the subjective field on the basis of considered hedonistic entities.

However, with regard to purging, it can be said that it aims towards equality in the sense that *two* or more incomes (generally two or more taxable objects) *equally* defined or conceived as net, perceived, available products, etc., must be economically reduced to homogeneous quantities through deductions so as to give rise to *equality* of imposition, according to the definition given.

III.

REASONS OF RATIONAL ECONOMIC ORDER THAT GIVE RISE TO TAXATION OF “NET” RATHER THAN “GROSS” INCOMES

In any case, the same historical process of substitution of objects of imposition can be explained, from an economic point of view, as a series of attempts to achieve equality of imposition, by refining the purging process and therefore the object of imposition.

If we consider agricultural production according to what Barone viewed as “rough Ricardian method”, it is possible to identify the domain of the logical need for equality in the abandonment of taxable subjects that, in the course of purging, are revealed to be *differently* charged. Let's consider the historical hypothesis of the imposition of gross product and gross income as attempts, later abandoned, to be replaced with equality of taxation achieved by considering net income, as the object in the field of *production* of wealth.

Historically the taxable object of direct taxes has gone through rudimentary phases such as: 1) to target income from land there used to be a land tax charged to the *extension* of cultivated land and the *number of means* of production (livestock, ploughs, etc.): an advance on this system was the charging of a tax in respect of *gross product*. An example of this was the *tithe* that, in fact, collected a tenth of production in kind;

2) to target the income of builders there used to be taxes on indices such as the length of the façade or the number of doors and windows;

3) to distribute taxes among those who received incomes of *moveable* nature (industrialists, traders and professionals) or work, there used to be *capitation* (a fixed sum per person) and later targeting of the gross product of these forms of activity, before modern taxes on net incomes.

The *reasons* for passing from taxation of gross products and income to net incomes, through appropriate processes of purging, are mainly of an *economic* nature.

For example, if *only* a tax on gross production (tithe) was collected from a landowner in the context of *juridical* distribution, the owner could in turn in fact distribute the tax to all factors of production, in other words those who had cooperated in the achievement of the product through contribution of circulating capital (means of instrumental work, of pure work, etc.). In this way, even though targeting a gross product, a tax would have been applied by economic *shifting* or juridical compensation, not only to the income of the owner, but also on the interest on circulating capital used by him, the salary of workers who had cooperated, etc.¹⁸².

In less advanced societies the economic subjects that had the right to the income, the interest and the salary were often the same person or family concern.

However, with the spreading of *division of labour* in all processes of production, the increasingly net figure of the subjects that cooperate in the achievement of the product has made the institution of *distinct* relationships of fiscal *law* with which to charge the *respective proportion* of the gross product due to individual participants in the production of a more logical approach.

¹⁸² There is a partial application of the system in law no. 276 of 29-6-1939 for the levy on agricultural income due by the owner of the land, with the right to compensation for those who participate in the distribution of the same income.

That is to say, alongside the tax on the *net* income from the land, taxes on the interest of capitals and on salaries have simultaneously been applied. If the *tithe* system had been left in place (on the gross product) where proportions of the product distributed among subjects participating in production had been subject to a tax, this would have given rise to a *double taxation*.

This fiscal absurdity can be defined – among the many ways of expressing the concept recalled above – as *repeated taxation, for the same reason or for the same fiscal assumption, of the same income or asset*.

To avoid double taxation and at the same time distribute the tax in a juridical context among distinct and identified subjects that receive a proportion of the gross product or income, it is necessary in fact to proceed to the *purging* of gross incomes, by deducting from them portions or adding *components* imputable to different subjects, and charged with distinct tributes.

Alongside the division of labour and the consequent specification of fiscal relationships, there is another important *economic reason* that creates the breakdown of gross incomes into net incomes for the apportionment of taxes on the basis of the principle of *objective equality* of the imposition. It is a matter relating to the diversity of the *existing relationships* between production expenditure and product, in other words between *costs and returns*, in enterprises of various natures, from agricultural ones to industrial and commercial ones.

a) Referring to the case just mentioned of agricultural production, following the historical development of taxation of this object,



Figura 20.

first of all we consider the hypothesis that land tributes are proportional to the *areas* of the cultivated land, regardless of their productivity.

In the hypothesis of a tax proportional to the surface area units (for example, per hectare), we can see what effect this produces on the relative position (*Ricardian return*) of those who cultivate land with different levels of productiveness. Let's consider two farmers, *A* and *B*, each farming respectively one unit of surface area, from which the first obtains *two* units and the second *one* unit of product, having incurred the same total cost in terms of capital and labour employed.

In the figure, the units produced are shown on the abscissa axis and the costs on the ordinate axis. *Op* is, in fact, double *pq*.

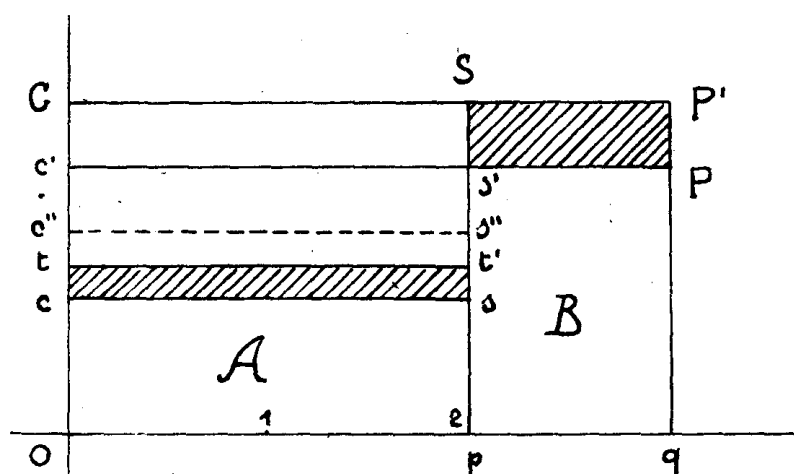
Let's suppose that, prior to the introduction of the tax per hectare, the market price is determined by the producer with the higher cost and that this coincides, in our hypothesis, with this cost. That is to say, let's suppose that $c'O = qP$, in other words, the second producer is the marginal one. In this case the *return* for the first producer is given by the area *cc's's*, after having incurred a cost *Op*.

If we introduce the tax and this, as it is frequently presumed – see the next chapter – has the effect of increasing the cost of production, it is the case that the burden is charged to the *unit produced* in terms of half in the first case (land producing double with the same total cost) and in

terms of the entire amount of the unit of the tax on the unit produced by the second farmer. In the graph Cc' is double tc , while clearly $ctt's = s'SP'P$. If the shaded area indicates the distribution by unit of product of the tax proportional to the *unit of surface area*, it is immediately clear from the geometrical diagram that the effect of the tribute has been to *increase the return*. This is so in the hypothesis that the market price has increased by the amount of the tax (added to the cost of the marginal producer), that is to say, regardless of the demand, in other words assuming the demand to be "inelastic or rigid". Indeed the area $tCS't' > cc's's$ represents the income.

On the other hand, the accentuation of income would not occur in the case in which different fertility levels led to a difference in cost at similar levels of produce per unit of surface to which the tax is proportional (for example, the same quantity produced at half the cost, as



Figura 22.

the hypothesis in a certain sense equivalent to that expressed above of double quantity at the same level of total cost per unit of surface area). Similarly, there would be no accentuation of income in the case of a tax charged to the number of units produced. In fact, considering the graph (figure 20), a similar tax would be charged to A , for example, for $cc's's$ double $s'PP'S$, as cc'' is equal to $c'C$. In that case $c''CS's''$ would be equal to $cc's's$; that is to say, farmer A would continue to enjoy the same income he had before the introduction of the tax specific to the units produced.

b) These arguments are valid, as has been clearly specified, in the hypothesis that demand is not a factor, in other words demand is considered to be rigid.

However, to consider the case closer to reality, if we presume that there is a certain degree of *elasticity of demand*, the conclusion indicated earlier is subject to possibly significant modification.

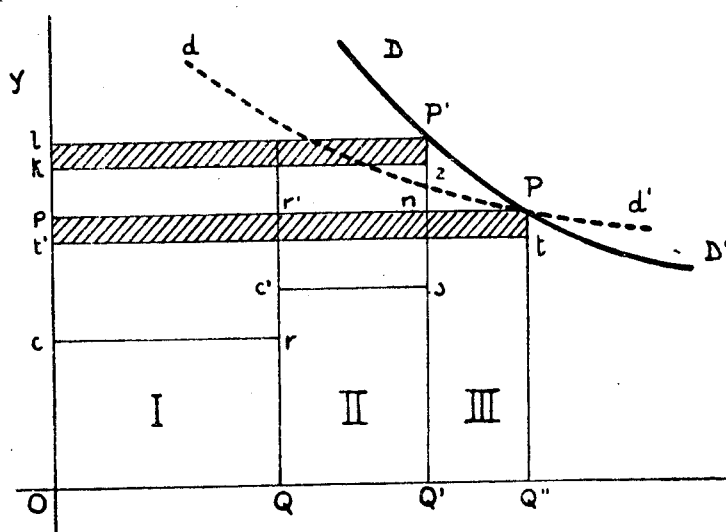
Let's take, for example, the case of the tax proportional to gross product (figure 22).

Let's consider three farmers of land I, II, III, with different costs of production. Let's presume that the market price is determined by the marginal producer (III) and that the other two producers achieve, in addition to the normal income allowed by the market to the marginal enterprise, also a differential *income* represented respectively by rectangles $pcrr'$ and $r'c's'n$.

A tax (tithe) that collects uniformly 1/10 (one-tenth) of the gross product can be considered to be equivalent (for example in Barone's hypothesis) to a *uniform reduction of price*. The representation of the hypothesis in the figure is given by rectangle $Ppt't'$, which has been shaded. Given the presumed demand curve (DD'), the marginal enterprise (III) cannot bear a reduction of price to a level lower than cost and therefore disappears from the market: the land remains therefore uncultivated.

The remaining enterprises can benefit from a higher price ($P'Q'$) which must, in turn, be reduced by a tenth. However, when this is deducted ($P'zkl$), enterprises I and II, respectively, nevertheless achieve a higher income than that they had before the tax.

The criticism (for example by Barone, who demonstrates it) aimed at the taxation of gross income (disregarding the differences in cost of production in agriculture) would be confirmed, in the sense that it can make income-related phenomena, in the Ricardian sense, more sensitive. The inequality that derives from the *direct* reference of the hypothesised tax (10% of gross product) compared to the *net* product, expressed in physical quantities or in *kind* is clear. I will discuss this in general terms here, with regard to the taxation of *monetary income*.

c) Let's now move to the hypothesis that the imposition is according to value, and that in a certain branch of *industrial* production there is an enterprise A that has a *gross* income, in monetary terms, of 2,000 units, after incurring an overall cost of 900 units. If the State charges, for example, a tax rate of 10% to the *gross* income, the collected tax of 200 units, compared to the net income of 1,100 units (2,000 - 900), is equivalent to a tax rate of 18.18% of net income. If in the *same* branch of production there is an enterprise B that achieves a gross income of 6,000 units, with an overall cost of 4,000 units, the 10% tax on *gross* income would be 600 units. If we compare this collection (600) to the *net* income of 2,000 (6,000 - 4,000), the tax rate is effectively 30% of the *net* income.

It is clear therefore that the imposition on the basis of gross income gives rise to inequality or violation of equality: in our example, the *same* tax rate (10%) charged to this economic entity results in a *different* taxation of *net* income: more precisely, the tax rate has become 18.18% for enterprise A and 30% for enterprise B.

In the light of the preceding arguments, reference to this simplification helps us to understand the rational foundation of the *purging* of gross incomes of all production expenditure, to reduce them to *net* income. The deduction of production expenses does not lead to fiscal *exemption* of the taxable matter in real imposition. However, as the proportions of gross income that represent *expenses* for a producer are *incomes* for other subjects involved in production, these incomes are separately subjected to the corresponding tax, so avoiding double taxation.

The semblance of exemption, which therefore appears to be in contradiction with purging, occurs in the case of deductions for persons dependent on the taxpayer, as the subject charged with the personal tax, as has been seen. However, these are deductions that, as the minimum exemption for the passive subject or taxpayer, are the logical consequence of the definition usually given to available overall income instantly or at a particular period in time. This can be enjoyed, *beyond* the minimum for life that is uniformly expected and excluded for taxpayers charged and in function of the different family composition (dependents), *beyond* the burden that differently affects the overall total incomes (passive interests) *beyond* the different qualities that are not *immediately* available (proportions of savings objectively verifiable for all subjects, as contributions to pension funds, insurance premiums, etc.) for the enjoyment at the *time* or period for which the synthesis of the flows of income is verified in the hands of the physical person.

In other words, it is not an exemption to deduct what is not taxable because it is not available for enjoyment coherently with the definition of the object; it is rather a coherent logic passage from an economic quantity given by the overall net income, through purging, to the expected (taxable) quantity in the context of public finance and of refining of the modes of distributing the cost of effectively indivisible public services in personal tributes.

On the other hand, in the field of real imposition after the analytical process of purging, the *sum* of net taxable incomes must be *equal to the overall gross income*, to avoid exemption or evasions.

However, disregarding exemptions – which do continue to exist in real taxes for various reasons – and evasions, and even presuming that the imposition is proportional, the State will *not* obtain the same revenue by passing from taxation of gross incomes to that of net incomes. This is because, through purging, incomes of different *types* from the point of view of the source (funded and non-funded) are analytically verified.

Therefore the *differentiation* of tax rates already illustrated in Chapter VI gives rise to a *lower* revenue, following the purging of what, at similar levels of gross income and tax rates, the State would obtain by taxing gross income. However, the most rational system, as has been seen, is that of taxation of net income in real imposition and of available income in personal income taxes.

APPENDIX

When we move from the expression of premises to their realisation in tributary systems, we observe that the State does not always carry out an analytical purging that takes into account real examples.

However, it often does make *assumptions* with regard to the production expenditure to be deducted from *gross* income to reach a net figure.

1) For example, with regard to income from land, *ordinary* (or normal) income is taxed as opposed to *actual* net income. This term introduces the concept of *average*, referring to a long period of time and to a *subject* (owner-taxpayer) who is neither the most able and diligent nor the least able and diligent.

When Italian law defined as taxable “income” gross production of the land *net of expenditure* and possible *losses*, it did not anticipate the scrutiny of the expenditure *actually* incurred year by year, but rather the deduction of production expenditure incurred *according to the customs and conditions* of each area. It is a *presumption of the law*, both with regard to gross income and for expenditure, which gave rise to what De Viti De Marco referred to as “tributary incomes”, both “positive” and “negative” ones, depending on whether the land owner was *more* or *less* average in terms of ability or production expenditure compared with the average presumed by the legislator. The same *presumptive* criterion is retained by the Royal Legislative Decree No. 589 of 4 April 1939, which updated the tariffs and base value of the Land Registry with regard to the sums to be deducted from production values to obtain the taxable “income”.

2) Similarly no purging was carried out, through analysis of real examples, in respect of the tax on *agricultural income* (before 1939 represented by the difference between gross product from the land and the combination of rental value and production expenditure) for individual agricultural enterprises. (Art. 4 of Law No. 976 of 29 June 1939 considers agricultural income subject to taxation to be represented by the income from working capital and managerial work, as indicated by agricultural valuations, excluding the income from any manual labour.)

In spite of what was required by the 1923 law, however, *net taxable* agricultural income valuation *tables* were adopted for each (average) *type* of land use. This is another case of the *presumption* of values to be deducted from gross income to reach a net figure.

Starting from 1940, agricultural income subject to the agricultural income tax (instituted with Royal Decree on 4 January 1923) is determined by *the same operations established* by Royal Legislative Decree No. 589 of 4 April 1939, in the establishment of the new Land Registry. The observations already made with regard to the purging of land income (deductions) therefore apply.

3) The same presumption *juris et de jure* was applied, until 1939, in the case of the verification of net taxable income from buildings used for accommodation. Since 1927 a *uniform proportion* of one-third of the gross income had been deducted from the *actual* income (as indicated by verified rental contracts) for maintenance and administration *expenses* and for possible losses (vacant periods). This presumption of the law gave rise to positive and negative “incomes” due to deviations of *actual* expenditure and losses from presumed *average* ones when differences in practice were taken into account for homes that were new or old, located centrally or peripherally, luxury, middle or working class, etc. The 1939 law partially redressed these differences by introducing the Property Register. This Registry, while retaining the practice of *uniform deductions*, differentiates between the various *categories* of homes (*luxury, middle class, working class*) for the purposes of deduction of expenditure, for the verification of ordinary by reduction of an amount (deduction), set at one-quarter of the gross income by the 1951 provision, which returns this situation, in this way, to 1865. The one-third deduction was adopted in 1927 as a political economic measure to alleviate the economic crisis.

4) The more analytical the purging, the more it reflects real examples, in the case of verification of the taxable income subject to category B) mobile wealth tax, with the deduction of *all* production expenditure, considered to be such by the law. However, for this tax, there is also no lack of cases in which law makes presumptions with regard to the deduction of some types of production

expenditure from the gross income. Such is the case, for example, of the presumption of uniform *amortization* quotes for the equipment of some *types* of production enterprises.

Occasionally the State *declines* to carry out *purging*: for example, in the case of passive (interest) annuities, when the domicile of the creditor in the State is not known. The producer is also taxed in respect of the interest, which is in fact an expenditure for him: he can reclaim this tax, by shifting, from the creditor. Similarly there is no apparent purging of the production expenditure that, for credit institutes, is represented by interest on bank deposits. Such interest due to deposit holders is not verified but their income, not deducted from the gross bank income as expenditure, is *formally* taxed by the credit institute, which reclaims this expenditure from deposit holders by setting interest rates that are *net of tax*.

5) Similarly, in the case of the supplementary tax on income, the overall income should be purged of the *expenditure that* the passive subject (head of household) *actually* incurs to support the *people* dependent on him (with rights to support). On the other hand, however, as we have seen, for the purpose of determining the *disposable* income for the physical person of the taxpayer, portions of overall *net* income are deducted, uniform for all taxpayers, as a function of the *number* of such dependants.

These *limited* applications of the *principle* of purging to a complex collection of examples, in practice take into account many elements of the real phenomenon (need) to reduce verification expenditure, to reduce evasion, to respect banking privacy, etc. However, in spite of the fact that these real compromises, the principle in theory retains its overall importance as a *rational* criterion for the objective and subjective equality of real and personal imposition, and as a procedure to prevent double taxation, which represents a violation of equal imposition.

CHAPTER IX.

THE ECONOMIC EFFECTS OF TAXES

I.

IMPORTANCE AND PLACEMENT OF THIS STUDY AS A CHAPTER ON PUBLIC FINANCE

1) With this heading, which has become traditional in the more comprehensive and recent theoretical treatises, I intend to illustrate the part of the course that corresponds to the second proposition (*b*) of the definition of this science.

Indeed, continuing to abide coherently by the method and illustration of the definition, we now move to the “*search for theoretical uniformities relating to the variations of specific equilibriums and of the more general economic equilibrium caused by the methods and extent of collections and, generally, the raising of revenues and the distribution of expenses, in the various market organisation hypotheses and the impact, or otherwise, of the time variable*”.

I will not claim to have exhausted the numerous problems that arise in the study of the *modes* according to which the State and lesser public bodies are able, with or without coercion, to generate revenue and fund the necessary expenditure to meet public needs: this is a theoretical and programmatic view that was in the formulation of the first part (*a*) of the recalled definition of theories and arguments regarding the choice of different types of tributes, when not dealing with questions that are commonly considered to be “technical” but are pertinent to economic logic. We will come across them in this second part of the course.

For now – compatibly with the proportions of a course of lessons – we can presume to have sufficiently expressed and demonstrated the *general* vision of the fundamental problems of financial activity referred to in the first proposition (*a*) of the definition of this science.

2) Having specified that the study of the effects of taxes, in other words, what used to be referred to as the examination of the “repercussions” of tributes and of their “shifting” or “incidence”, corresponds to the second part of the course, as has been indicated here with reference to the first paragraph of the *Introduction*, we can proceed to make further preliminary clarifications.

Already what has been expressed and what has been stated (in the previous paragraph I) can be used to obtain the reader’s and the student’s consensus, in particular with regard to the denial I suggest regarding one of the most frequent statements by academics. Indeed, the opinion of Myrdal (pp. 17-18), for example, has already been cited, according to whom the incidence or the effects of fiscal systems are the *only* content of the science of finance. This author, whom we could define as a pessimistic and “*a priori*” critic of this scientific approach, in any case repeats what numerous other authors, including some Italian authors, have already said. To find the same expression in Italian treatises, it is enough to recall for example that Fubini states (*Lezioni di scienza della finanza [Lessons of the science of finance]*, Cedam, 1934, p. 76), after having clearly agreed with the common opinion, of which Seligman¹⁸³ () was the spokesperson, in the systematic treatment and historical review of specific theories, by saying that “there is no more important subject” than public finance (Fubini thought it “essential”). Our illustrious academic thought it was, furthermore “perhaps *the only* real scientific problem of this discipline”. Essentially he is not the only one to think this way, if we look back to the phase in economic thought where the science of finance was considered simply a chapter of political economy, mainly because dealing with shifting and incidence was considered to be dealing with “doctrine of value” or “an issue of prices”. (So stated for example Seligman, confirming Marshall’s view, who thought “the theory of the incidence is an integral part of the general theory of ‘value’”.)

¹⁸³ *La traslazione e incidenza delle imposte [Translation and incidence of levies]*, first Italian translation in the Economist Series Library, Series V, vol. VI.

As I have said before, I hope to have demonstrated so far that what relates to the study of the activity of the State and other lesser bodies belongs to and confers relevant content to financial theory, intended in the stricter rationalistic meaning, according to the vision in (a) contained in the definition at the beginning of this course. What follows is the chapter on effects, that we can generally admit, according to Seligman, “was one of the first to attract the attention of those writing about economy” (p. 140); it will demonstrate even more how partial the statement literally expressed by Myrdal or Fubini, and others with essentially the same approach, was in restricting without rational foundation the content of the science of finance, even if only on respect of economic content, as it is practised and pursued in these pages. It is something else to admit, as some do, that the problem of the economic effects of tributes is one of the “greatest and most complex” problems of financial economy. This is also demonstrated in this university “course”.

3) It is now necessary to explain the reason for the logical sequence that makes the two propositions [a) and b)] of the definition follow according to the order in the same definition. The observation is not out of place if we think, analysing international literature, that many authors present the study of the effects of taxes or of the repercussions that they cause on the economic equilibrium before the study of the modes through which the distribution of taxes and the achievement of revenue is generally implemented.

Excluding the cases in which there is no considered reason, in “courses” and treatises, for a given order of the fundamental chapters of this science, it is here stated that there exist different logical points of view from which the order in which they are presented is derived. Theoretically these are the two main aspects of financial activity recalled under letters a) and b) of the formulation that define our discipline in the *Introduction*.

A) Referring also to the historical development of the theory – which is put forward by Seligman as a premise of the study of the shifting of tributes – we can mention the one called “optimistic” theory, which refers to Thiers and Canard and which was suggested in terms of the “diffusion” or the equal diffusion of taxes. The former stated that tributes are indefinitely transferred and that they tend to become part of the price of goods, so that everyone bears part of its burden, not in proportion to what he pays to the State but in terms of what he consumes. According to Canard, whether the tax is direct or indirect, whether it is aimed at one or other social class, whether it has one object or another, it always ends up being distributed across the nation, in a *uniform* way among producers (sellers) and consumers.

In this vision that considers a systematic and, in a way, an automatic and indefinite redistribution of the tax, compatible with equal or uniform imposition, the two distinct problems [a) and b)] that are fundamental in financial activity and that are set by the theory lose their own logical autonomy and merge in a single solution. In fact the economic distribution, (admitted that it is) informed by a presumed equality according to the optimistic vision here recalled, implements equality regardless of the juridical distribution. Actual divergences from uniform taxation, due to the action of the indefinite shifting, are considered temporary disturbances with respect to the final condition in which each taxpayer will find himself taxed on the basis of his own wealth, his own sales or his own purchases or consumptions. With regard to the latter, the decrease in consumption would extend to all goods.

It is not of interest here to immediately point out the errors of this optimistic approach to the problem of the economic effects of the imposition: it is a demonstration that many authors have carried out and that will emerge from the close examination in these pages, with which the Thiers–Canard concept will become incompatible.

However, it is enough here to observe that in the context of this concept it does not matter that the analysis of the *modes* of distribution of tributes or the obtaining of fiscal revenues comes first, as ultimately the *real* burden of the distribution process is entrusted to their economic distribution, or to the variations of economic equilibrium more or less extensively intended.

B) From another point of view it would be irrelevant to have the problem of the economic effects of the imposition (in the various meanings that will be specified) precede that of the juridical

and technical modes of the distribution of tributes: this is the *pessimistic* point of view of Proudhon or Bolles, according to whom, because of the absence of “a law” or of a “uniform rule” with regard to shifting of taxes, as some taxpayers can and other cannot transfer to third parties the taxes charged to them by the legislation, the entire tax system leads to great inequalities.

In this case there would not be the logical link necessary between the two main issues [a) and b)] that are the object of theoretical studies, as the absence of uniformity of burdens in the context of economic effects or shifting or incidence of taxes can make “unjust” a tribute which “in the beginning” was equally set.

Nevertheless this last proposition of the pessimists could justify the illustration at first (“in the beginning”) of the equality or justice of the modes of fiscal imposition, and later the demonstration of the effective inequality due to the uncertainty of the process of shifting of the same tributes.

C) An intermediate position would put forward, at a glance, both the independence of the two fundamental problems indicated in the definition of this science that I have given: that of those who, starting with Fauveau, Cournot’s follower, up to some contemporary experts, sceptically conclude that a tax, equal at the start, can become unequal over time, as there is no such thing as equal diffusion of tributes; similarly, it is probable that a tax that is unequal at the stage of juridical distribution may become equal in the context of its actual distribution.

Independence is intended here in the sense that the logic of the conditions of fact that preside over the effective distribution of tributes can determine various modes of their distribution, whatever the criterion enshrined in the legislation.

However, the definitive range of formal distribution is demonstrated also in this logical position by the study of the effects of tributes in the sense, first of all, of their shifting. This leads to the belief of the rationality of following the treatment of the problem of hypothesised criteria or modes of formal or juridical distribution with the treatment of the effective economic distribution, even if in hypothetical conditions.

D) According to some, there should be no link between the two problems, in the sense of the study of the divergence of the hypothetical factual distribution from the juridical one, because both the intentions of the legislator and the incidental facts may vary. So it would be best to ignore the intentions of the legislator (all the more because, according to Dalton, the legislator often does not take into account or is not aware of the problem of shifting).

This view is not admissible because of the contradiction that does not allow us to disregard the intention of the legislator, even if hypothetical, because: α) either it is objectively enshrined, as spirit of the law, in the juridical directions that indicate that all law obligations are also factual obligations, and it is necessary to demonstrate the coincidence of the two distributions; β) in other words, the supposed law requires certain subjects (i.e. producers, sellers, etc.) to pay taxes, but it does so with the aim of these taxes being shifted to consumers of goods and services. It is then necessary to demonstrate that the mode and the technique of the formal or juridical distribution are different from those that are literally present in the hypothetical law, when this does not provide explicitly the power of juridical compensation, which might become economic shifting, or when this occurs independently from the granted legislative power only due to systematic conditions or circumstances favourable to the variation of prices of the same goods and services.

It is then necessary to demonstrate that the mode and the technique of the formal or juridical distribution are different from those that are literally present in the hypothetical law, when this does not provide explicitly the power of juridical compensation, which might become economic shifting, or when this occurs independently from the granted legislative power only due to systematic conditions or circumstances favourable to the variation of prices of the same goods and services.

In any case, even when examining literature from abroad, this systematically deals in an explicit way in monograph and treatises with the “opinions” of legislators and their intentions, for the obvious need to interpret the abstract *spirit of the law*, including by experts of financial economy who, precisely, adopt the legislator’s intention as *hypothesis of study*, drawn more or less from facts.

In any case, when this admission or research is not explicit, it emerges indirectly when the problem of who *effectively* pays the tax is considered, a statement that implicates inevitable contrast between those who anticipate in monetary terms the *amount* due by law and those who *actually* pay the tribute. Furthermore, in searching for who in practice pays the tribute, if we say that we intend to verify the occurrence of “undesired” results, we implicitly admit there might be an intention different from the verified one. Therefore: a logic of the mode of distribution of *actual* tributes, expected as a function of the shifting process.

, Through the study of the action of economic forces that “alter” the juridical distribution of tributes, in other words their mode of distribution, others suggest not only the difference in the effective distribution from that which the presumed legislator had “*intended*” to implement should be verified, but also the divergence from what appears to emerge from the sum *paid* by each individual or enterprise for the tax, considering the further effects (incidence of profits) in the context of the economic distribution of tributes.

Nevertheless the demonstration of the opinion indicated at the start of this paragraph (*D*) contributes to logically justifying the priority that, in this course, has been given to the problem of distribution, as modes of achieving revenues by bodies that specifically collect tributes, when compared to the problem of the economic effects of taxes that, in fact, follows in our presentation. Here it is intended to give explicit explanation of the sequence, an explanation that nearly always is missing in written works that follow this logical presentation order.

E) New elements can be put forward with regard to the relationship between the two issues [*a*) and *b*)] in the definition adopted here of public finance economy.

Both can be considered independently, by identifying in them the only common element of the theoretical characteristic, in the sense that both the analysis of incidence or shifting or effects of taxes and the logical explanation of the modes of distributing the fiscal burden among taxpayers are elements of pure science. From this point of view, Edgeworth for example, at the beginning of his well-known treatise (*La teoria pura dell'imposta [The pure theory of taxation], op. cit.*), admits that the science of taxation includes two subjects to which the characteristics of pure theory can be ascribed: the laws of incidence and the principle of the equality of sacrifice. The common characteristic is derived from the logical process that is illustrated in the *Introduction* to this “course”, as Edgeworth admits, at the beginning of the second study which deals with the “principle of the justice of taxation”: I am referring here to the deduction from accepted first principles. We could make reference to deductions from hypotheses, including among them also those relating to the objectives or intentions or opinions of the legislator.

In other words, in pure theory or in abstract argument, it is possible to disregard the logical links between two circumstances of the formal or juridical and economic distribution, proceeding independently to examine the logic (for the economic part in particular) that: 1) presides over the juridical and technical choice (science of modes) of the tributes or revenues, in particular fiscal ones; 2) dominates the actual distribution of tributes, on the basis of economic analysis, that in the science of public finance proceeds by further approximations (see the *Introduction*) and considers the numerous and complex conditions and circumstances from which shifting of tributes can derive.

In brief: *α*) it is possible to consider the economic effects of tributes, *given* a juridical *distribution* whose logic it is intended to investigate (modes); *β*) it is possible to consider a juridical distribution of tributes on the basis of various premises, principles, postulates, hypotheses, assuming the actual distribution to be *given* or known, in the sense for example of the limit case where it coincides with the hypothesised legislative one; *γ*) it is possible to consider the logic of an *actual* distribution (for example special or general tax on consumed income) when the shifting that has taken place is taken as a *given*, for example the shifting on the consumers of a tribute of the type that juridically and technically has been charged to trading producers, etc., as subject of the law.

On the other hand, even admitting these methodological and conventional points of view that, strictly speaking, allow the indifference in the *order* of the indicated hypotheses and problems [(*a*) distribution by law or choice of methods, and (*b*) variation of the economic relationships due to this distribution or to the variation of concurrent circumstances and conditions], it can be said that the very

objective of knowledge of observable events suggests giving precedence, which is historical and logical at the same time, to formal distribution in order to study, therefore, its final outcome in light of the interference of economic events or of forces of this type that break down or modify the first hypothesised distribution.

This concept is actually expressed by Taylor (*op. cit.*) when he states incidentally that “financial theory starts with ideals of justice that are reflected in the specific legislation”.

F) However, I would not say that they are entirely independent problems in the sense that equality, justice, etc., are concepts that, once defined, act as given facts or hypotheses in theoretical arguments only for formal distribution (mode); the case of the study of the economic effects of the imposition is outside the issue of equal distribution only because conventionally, as I have just said (paragraph D), it is possible to separate the two fundamental temporal moments.

Indeed, let's examine for example Einaudi's statement (which is not acceptable for indirect taxes when there has been technical or juridical distribution, however, as this presumes the possibility of modifying it, with shifting to third subjects, as in the case of taxation of consumption). He writes: “A tax system can be designed in such a way that distribution is considered to be *equal* by the taxpayer. To ensure that equality is present not only in the text of the law but also in reality, it is necessary that taxes are effectively paid by those persons that the legislator has ordered to pay”. He continues: “Here there is another serious problem, which is no longer the issue of equality but of the actual consequences of the imposition. Is it not possible that a tax charged to one person is paid by another? If those people who actually pay the tax are different from those indicated by the legislator, can not the system which was equal in the first place become a completely different system which can be judged in a completely different way?” (n. 296, 1940 edition).

This proposition, which is not discussed in detail, confirms the views expressed in these pages: that is to say, that it is quite true, as Einaudi observes, that these are *in themselves* different problems in the sense that it is possible to analyse the effects of a tax disregarding the considerations and conclusions about the gap between the intentions of the legislator and the results observed by an objective economic investigation on the shifting or incidence or the various economic effects of the imposition. Let's be clear, however, that in this way we study *an aspect* of the financial problem, as we can conclude from the words of the same Einaudi.

Similarly with Borgatta: “The judgment that can be given of a tax system does not depend only on the principles that inspire it but above all on the results that it actually achieves. The play of economic forces, the effectiveness or otherwise of the administrative action in verification and collection, can make the actual results of taxes quite different from those that the legislator had envisaged; they can make a tax system rigorously designed according to the norms of generality and uniformity of the imposition unjust and unequal. The study of the effects of taxes is therefore quite important, both for the practical purpose of being able to forecast its consequences, and for highlighting the differences between the fiscal reality and the norms established by the law.”

This confirms that the *only* problem of distribution of taxes according to ideals or hypotheses of justice (or of equality, which is the main expression of it in financial activity) is scientifically approached in an integral way not only when we hypothesise for example the action of hedonistic entities (such as utility) and when we argue on the basis of these or other objective entities that explain the equality of the imposition, but also when we support the hypothesis of given modes of distribution, keeping in mind the correspondence between the same hypothesis with the hypothetical reality which, in turn, is highlighted by the study of the effects of the imposition.

For example: 1) it is possible to analyse the equality of the imposition when the formal distribution by virtue of law *coincides* with the factual one, this latter being essentially highlighted by the study of the effects or of the definitive or real incidence of the fiscal burden; 2) it is possible to make the hypothesis of equality of the imposition on consumed income through the purchase of services and goods that are taxed when, having formally chosen different modes of distributing tributes charged to persons other than consumers, the theoretical (and in practice also the difficult statistical) analysis of the shifting demonstrates that actually the hypothesis of the special or general tribute on consumed income corresponds to the hypothesis selected.

For example, to criticise the *presumed* uniform taxation, through taxes on individual consumptions or on groups of services and goods consumed, it is necessary to consider the economic effects (which do not affect only monetary shifting or incidence) of the system of distribution of tributes on consumptions to demonstrate that the presumed equality or postulated uniformity are not valid in light of the economic analysis of the consequences of the chosen mode by the presumed legislator. Anticipating what will be observed later, it is possible to note in the meantime that it is precisely the analysis of the effects of taxes that allows us to state that a tribute on consumption of the type hypothesised here actually affects relatively more beneficiaries of smaller incomes than it affects incomes equally.

Seligman suggests, in “advising” the legislator on the basis of the “correct theory of incidence”, taxes whose results can be forecast quite accurately by indicating, on the one hand, “taxes whose probability of shifting are very small” and, on the other, “taxes that can be completely transferred”. “In the first category are included,” – according to Seligman – “some taxes on monopolies, net profits, successions and some forms of property and income. In the second category are included taxes on goods in the form of import duty, some duties on consumption and licence taxes and taxes on gross income of trading companies”. “If the legislator wishes to charge directly some classes of society he needs first to choose the type of tax; if he wishes that taxes are paid without the taxpayer being aware of it, he ought to choose to second. If one or other type of tax is not enough for public revenues, the legislator will be obliged, as often happens, to turn to taxes whose incidence is more uncertain and in which the intentions of the legislator can be completely frustrated by the course of events” (*op. cit.* pp. 252-253).

It is not of interest here to highlight those such as, for example, Sensini (*Le equazioni dell'equilibrio economico nell'ipotesi di sottrazioni di ricchezza operate dal governo [The equations of economic equilibrium in the hypothesis of deductions of wealth carried out by the government]*, etc., “Economist Journal”, August 1930), who, in reporting his thought, defines Seligman’s “obvious errors”, given that the relativity of the statements of the quoted text can be appreciated as our study of the hypothetical case histories unfolds. Once this has been admitted, some of the uniformities of the same American author can be admissible as logically plausible.

However, what I am interested in observing, according to the view on which I insist in this premise to the study of the effects of taxes, also encountered in Seligman’s propositions – which from a methodological point of view he should not have defined as “advice” as this suggests a context of art and not of financial science – is the following point: that is to say, that the hypotheses on the modes of distributing taxes on the basis of various premises, of which Seligman provides examples, as has been said before, *precede* as legislative or political objectives translated from the modes of collection of tributes, with respect to the vision of the effects or the incidence of tributes. This moment *follows*, nearly as a confirmation or verification of the suitability of the chosen means with respect to the distributive objectives in the context of tax.

Seligman appears to be aware of this *correlation* that intercedes between the two fundamental issues [*a*] and [*b*]] of my definition in the logical and explanatory order I have adopted here. Indeed, he continues, in the conclusion to his work on the review of theories and his own analysis on the theme of incidence:

“The theory of incidence therefore has significant but not decisive advice [*sic*] to give in the elaboration of a tax system. It does not give exemption in any way from the study of the principles of justice and of fiscal equality. If the optimistic, pessimistic or agnostic theory of incidence can no longer be supported, the public finance academic must try to elaborate the rules of equal taxation without trusting unto the automatic action of presumed absolute laws. He must try to make a choice in terms of public revenue that satisfies in itself the needs of the principles of economic justice; in doing so he can let himself be guided by principles of incidence but only those that have been defined and are accurately verified. The theory of shifting of tributes is therefore of assistance but it cannot replace the study of economic justice. As it has already been said, the doctrine of incidence is neither the hero nor the villain in the science of finance”.

Disregarding the imperfections of definition and of method (in the *Introduction* I adopted criteria that authorise the shifting of the “choice” of taxes that Seligman discusses into “hypotheses”

of public revenues), it can be noted in this author the vision of the necessary *relationship* that runs between two problems (in themselves, for convenience of investigation, able to be analysed separately) for the purpose of the coherent and realistic identification of the study hypotheses of the financial phenomenon. The “assistance” that the theory of incidence can provide consists in the verification of the hypotheses so that they do not arise in opposition *to* reality (even if far from reality, which is methodologically acceptable). Bühler even states that if “States were to become familiar with the effects of taxes and expenditure, they could avoid many omissions and correct their own errors”. Omissions and errors cannot but be observed in visions that arise as logical and historical *antecedent* with regard to the study of incidence, which would highlight them. The same order of implicit arguments can be observed in Taylor (*op. cit.*, p. 281) when he states that “the recognition that the burden of a given tax does not fall necessarily on the person that pays it originally will help us to avoid logical errors in the analysis of the burden of particular taxes”. That is to say, these taxes are hypothesised on the basis of given presumptions that relate to the modes of distribution of tributes, modes whose logic can be based on coherent arguments on the basis of given premises, such as those put forward in these preliminary cautionary notes, presuming the incidence is simultaneous with the hypothesised legislative distribution. Indeed, in dealing with the previous theories in the first part of this “course” [proposition *a*) of the definition], the argument has provisionally assumed *as if* equality and justice refer to subjects who pay taxes, without taking into account the effects of the collection and of the distribution of tributes other than in the case of the relative contributive capacity that arises, precisely, as a concept derived from the introduction of the hypothesis of the different utilisation or the different effects of public expenditure and other State services on individuals and groups of taxpayers.

[However, also seen in the specific case of the “relative” contributive capacity, we started from the simple hypothesis of the capacity that I defined as “absolute”, progressing to *then* consider the effects of the expenditure (presuming in this way that only the burden of collection as abstract mode of distribution of taxes to have been modified). This is also a procedure to allow the integration of a theory of first approximation.]

Generally, the study of the effect of taxes that, so limited, allows us to consider as an end in itself in terms of the theoretical analysis of the modifications of the particular and general equilibrium due to the collection and distribution of fiscal revenue, also has the logical function to allow the *verification of hypotheses* when these, in the context of the distribution of tributes, for example when they *presume* the incidence on categories of subjects corresponding to the individual general or particular taxes. As we will see, there are too many variable circumstances that can be hypothesised to reflect reality even remotely, to be able to be satisfied with a formulation of the hypotheses on the modes of distribution of tributes without testing the degree of relativity of these same hypotheses.

With this, after having criticised Seligman for the “advice” that should be given to the legislator, it is not intended to limit the field of variation of the multiple and changeable presumptions that influence the choice of taxes in a legislative context to the vision of shifting or incidence of tributes as the *basis* of fiscal systems. What Sensini states (*op. cit.*) is true, that “the governing classes of one community, in the context of the imposition of tributes, are motivated by reasons perhaps different from the simple desire to follow the advice of the correct theory of incidence”. However, I believe that *trend* analysis of the effective distribution of the burden of tributes is useful in avoiding contradictions between intentions and results.

It is also for this reason that the public finance economy academic highlights the aspect of the corrective interference that is carried out with the vision of the effects of taxes *after* having hypothesised logical modes of distributing tributes, on the basis of other premises: this is so because he believes, as a theoretician, that the investigation of the overall phenomenon is not resolved by the study of the combination or the concurrence of these two aspects analysed by financial science, given that the economy theoretician has mainly shed light on the economic aspects of formal and substantial distribution of tributes, respectively.

G) The reader may forgive these, perhaps too expansive, introductory notes that intend not only to explain the non-arbitrary but logical succession of the two great issues of this science, such as

those stated in the definition of the same, but also the dissatisfaction felt in observing the lack of connections (and not only in terms of justification of the reason of the explanatory order adopted in the presentation of these two issues) between the two fundamental parts of the subject that has led me to make explicit the links that *may* connect the various sections of the current treatise.

A proof of the necessity of finding an adequate and open relationship between the aspects of the phenomenon for the hypotheses that allow their elaboration is found in reading the justification given in the work that I admire the most, in terms of scientific construction. I am referring to De Viti De Marco's *Principi [Principles]*. This master places "the juridical distribution of the tax" after the "theory of shifting". Let's consider the logical thread that links these two issues: "From the theory of shifting results the fact that, all other conditions being equal, an equal general tax on all incomes disturbs the economic equilibrium less than an adequately higher partial tax. This is the economic basis of the juridical and political principle that all citizens are equal before the fiscal law. This principle, which reflects society's general sentiment, also shapes the political constitutions of modern States: however, it does not have a concrete and positive content, as is normally the case with abstract and absolute rights declarations. It has rather the value of a critical and negative trend against specific historical forms of fiscal exemptions".

I will not discuss these latter propositions in the sense that the shifting of taxes, by identifying the tributes that less disturb the economic equilibrium, should have provided the basis of the juridical and political principle of equality. If anything, history has demonstrated the contrary. That is to say, as the principles of equality have been progressively declared on the basis of arguments and, even more so, sentiments and impulses of the components of the governing classes, and as we have moved from the absolute State to the modern democratic State, the distribution of tributes has been adapted to the juridical constitutional premises.

Indeed, in the preceding section (on the modes of distribution of tributes) I have insisted in this "course" on saying that the definition is derived from politics, social ethics, the constitutions, etc., as is the concept of justice and of equality that, as a modern development, characterises state constitutions. Therefore, in accordance with this, we study the modes of distribution of tributes. Then, as I have indicated, the effects of the tributes presumed to be charged to those who have been identified as classes or individual taxpayers have been analysed with the purpose of verifying the hypotheses on these same modes of distribution of fiscal burdens, in the context of expression of juridical or formal equality, translated also in terms of hedonistic and economic objectives.

However, leaving aside this aspect of De Viti's vision, what is of interest to observe here is the statement that an equal general tax on all incomes disturbs the economic equilibrium less than an adequately higher partial tax. As a provisional hypothesis, it is possible to admit that the general tax, which affects all purposes, does not *directly* influence the pre-existing offer because, as the demand varies due to the type of tax, there will be an indirect process of adjustment of the offer to the demand. However this comparison is carried out in the hypothesis of exclusion of the argument on the effects of the distribution of the revenue of the general tax. This simultaneous close examination of the effects, which De Viti De Marco has significantly systematised up to now, does not legitimise the statement that this tax disturbs the economic equilibrium less than an adequately higher partial tax. In addition, this statement, which is debatable in a rational context, which this illustrious author has expanded, cannot be considered to justify the logical necessity to place the study of the effects of the tax ahead of its juridical distribution.

Indeed when, due to a complex set of arguments and impulses, constitutions first and special legislations later have sanctioned justice in terms of equality in subjects with regard to their fiscal duties, this has led to the embodiment and legitimisation of the principles in the modes of distribution of tributes. The subsequent study of the effects of the same on the economic equilibrium may lead to the belief, also in fact, considering the influences or repercussions of the types of tributes, that they are not contradictory or are relatively contradictory to the modes in the distribution of the relative effects. However, this is not, of course, with the admission that would conclude De Viti's investigation with regard to the lesser inclination to modify the economic equilibrium, which he believes to be the characteristic of a general tax, closer to the ideal of equality: this is so because, as we will see later, this can be true in a first approximation or by considering this from the points of

view (which he defines of the classics) that De Viti De Marco maintains he has overcome in respect of the more limited models that our author defines to be incorrect.

It is true that De Viti *mixes* in a single criterion the equality of the distribution of tributes with its inclination to minimally disturb the existing economic equilibrium. What matters, however, in this explanation of the logical order of the treatment is the recognition on the part of this master that is expressed in the following terms: “Only *after* having exhausted all means (or modes) to avoid inequality (in other words, to obtain equality), it is possible to leave to the natural play of economic forces the task of levelling those residual inequalities that the law could not affect”. In the meantime this (against the order followed in his presentation, in which the study of the effects of taxes *comes first* and the juridical distribution *follows*) confirms that this logical and historical *precedence* is equal distribution or without distribution without inequalities in the legislative context. Furthermore De Viti deals with reactions of economic forces “initiated by the juridical distribution” (p. 135) to highlight the divergence or the convergence of actual situations that derive from them, with regard to the juridical distribution on the basis of preconditional criteria of equality. This is therefore the *preliminary* action that causes economic reactions that come later or are functionally *dependent* on them.

This is the same inevitable consequence that De Viti De Marco had envisaged, after synthesising the theory according to traditional events (that I outline with regard to the finalistic principle) of the effects of taxes. Indeed in conclusion he came to the following “general principle” (p. 119): “The combined action of the economic forces of shifting, of diffusion, of evasion, of consolidation, drives against the *return* to an equilibrium dominated by the action of economic forces if this *was broken* or modified by a contrasting juridical distribution”. The “distant past” tense adopted for the formal distribution or the modes adopted by the legislator to achieve revenues for the State or other body, and the “present day” tense used for the case of reaction to economic forces (that is to say, mainly for the effects of the imposition) explain not only the logical but also the temporal priority, justifying an explanatory order *opposite* that which the same De Viti adopted in his compelling and outstanding theoretical construction.

What needs to be stated above all, in reducing or nullifying the logical importance of the connection between types of (general) taxes and this mode of distributing the tribute, is the *non-necessity* of the connection. This is so because, as we have already said, the general and uniform imposition can *derive* directly from the shifting, in economic terms, of the equality of duties towards the State of members of the modern community, juridically organised.

Probably for the purpose of avoiding “a priori” contradictions between the distribution in law and distribution in fact, in other words between the modes of collection and the variations in equilibrium and repercussions of tributes, Barone placed the study of shifting of tributes *after* the treatment of the principles concerning the modes or criteria for the distribution of tributes, stating that “it is not possible to seriously discuss a fiscal system without knowing who is actually affected by the tribute charged to Joe Bloggs”. This means that the hypothesis of the implemented total shifting of tributes whose rationality is considered in light, for example, of fiscal equality may not be enough (not in terms of pure logic, clearly; the criticism would be against the methodology in our *Introduction*) when it is intended to explain concrete systems, technically and juridically approached so as to give rise to an incidence different from that which was hypothesised.

For this approximation to reality that remains one of the aims of inventive science, the chapter on the modes of distribution of tributes was given precedence, on the basis of determined premises. Now we move to the issue of the effects of the imposition, noting perhaps in too lengthy a way the connections between the two parts. This is so as to avoid doubts concerning the rational relationships between the two objects [*a*] and [*b*]] of the science that I have defined at the start of the “course”. Nearly all authors fail to offer explanations, or sufficiently adequate explanations, of the reasons for the presentation order of the matter in these pages.

What has already been noted in these preliminary warnings *also* acts as a verification of the study of the effects of the imposition in the context of a hypothetical experiment of the hypotheses considered and those that will be considered later with regard to the modes of collection of revenues, in particular fiscal ones.

Lastly, a concept of the two issues or moments that give content to this science does not appear to have logical significance when the study of the variations of equilibrium is presented as that of the modes to implement the justice of the imposition with the purpose of distributing the cost of action by the State. This is so because, for example in an *alternative* way, the following criteria are proposed as *modes* of distribution of taxes: the equality of burdens, the cost of services used, the value of the advantages achieved by State services, the contributive capacity, the contingent opportunity and the *effects of taxes* (Bühler's, *op. cit.* 317/18).

What precedes in these introductory paragraphs on this latter subject helps us to understand that we are not dealing with alternative but, if anything, with correlative criteria when the effects of taxes are placed in a relationship with the modes or criteria of the juridical or formal distribution of tributes. Adapting Riau's words, it could be said that: "shifting cannot justify an unjust taxation system".

In this sense, and not with the meaning of an alternative, it is possible to accept the thought with which Seligman starts his own treatise on the incidence of taxes, when he states that "without a correct analysis of the incidence of a tax, it is not possible to form an opinion on its real effects or its justice."

II.

THE PRINCIPLE OF CAUSALITY AND FINALITY AND THE ATOMISTIC APPROACH TO THE PROBLEM OF THE ECONOMIC EFFECTS OF TAXES; THE DETERMINISTIC PRINCIPLE AND THE APPROACH TO THE PROBLEM ACCORDING TO THE GENERAL ECONOMIC EQUILIBRIUM.

In the *Introduction* (III), when referring to the theoretical problems of public finance economy and in particular to the one I am examining here, of the *effect* of the interference of the State, with collection of revenues and distribution of expenditure, it was stated that the appropriate principles to logically contextualise our research would be generally applied.

They were: *a) causality* principles (in the philosophical and not the physical sense), *b) determinism* and *c) finalism* or finality.

A) In this treatise, the first principle can help in explaining why the generic term of economic effects of the imposition or of tributes is adopted in this chapter, when we attach the meaning of efficient cause to the concept of "cause", in the case of (State) action appropriate in producing these phenomena or to provoke consequences. However, as we are dealing with its application to human behaviour, causality is coordinated or is transformed into finalism, as these are the most appropriate motivations to explain it.

B) The finality principle (which I rationally consider to be of secondary importance in the order of application to problems of finance and which can represent the most up-to-date vision for the explanation of phenomena in relation to physical sciences) serves the purpose of identifying two modes of approaching the problem in a less generic way and of clarifying them more rationally than has been done up to now.

Indeed, as has been said, the finality principle explains in a more appropriate way than that of causality the theoretical position that unconsciously, in other words, without taking this scientific (finalistic) concept into account, has been adopted by the experts of financial economy in the framing of the issue of the effects of taxes, qualified as a problem of shifting or of incidence.

This is the atomistic position that refers to individual passive subjects of the fiscal duty ascribed to them by hypothetical laws or the will of the governing classes. Individuals, linked to hedonistic objectives measured or indicated by maximums or defined by objective maximum utility, when faced (simple announcement or verification and notification of fiscal duty) with the fiscal burden, *tend* not to distance themselves permanently or to return or to exceed the condition of maximum satisfaction or of monetary profit, which is *one* of the modes, as we have seen (progressive imposition) of obtaining satisfaction: the maximum position in which each will find themselves before

the interference of the fiscal event, considered only as a lessening of means at their disposal or produced or received by them.

If the objective is the maximum satisfaction or happiness, according to the finality principle, the human personality is motivated by “objectives” and not by “causes”. The phenomenon of syntrophy (so called by physicists-mathematicians) or of convergence, not experimentable but conceivable as an end in itself, is *motivated by its “objective”* (FANTAPPIÈ, *op. cit.*, p. 98) in the same way as the entropic phenomenon, causable or reproducible, presumes its own “cause” according to older and experimental science.

In the finalistic and atomistic sense (reference to single subjects) what was defined as the generic effect of tributes (on the basis of the effective causality principle) is expressed as a phenomenon of shifting, of incidence or of diffusion (in the sense that will shortly be specified) in a *trend* phenomenon in relation to which financial economy has explained and continues to explain the laws, observing and hypothesising the human conduct or behaviour or of the subjects to whom the tributes of various types are charged.

This finalistic position, in other words of the trend to return or to overtake maximum hedonistic and objective points (in monetary terms) linked to a private economic activity, is a trend that the theoretician presumes to be operating in the explanation of the conscious reason of the subject charged of the imposition, and emerges, as I was saying, unconscious of old and recent treatments in which it was intended to analyse the *effects* of the imposition. The two points of view could be said to be convergent if the tax has the effect of persuading subjects to review their hedonistic calculations. However, these are dominated by trends towards objectives, as it appears in the treatises in which the following statements are found:

a) producers “*will try to compensate*” for the tax (which according to some would increase the cost of production and so increase the price); *b)* one person who pays the tax *tries to escape from it*, by transferring it to another person; *c)* a person who has a certain income and who is obliged to allocate part of it to tax, must *modify* his behaviour (keeping in mind that the collection implies *sacrifice of utility*); *d)* the person who pays the tax may sometimes *reimburse* themselves through a new exchange process that allows them to *reject it* onto other economies; *e)* the taxpayer *suffers* repercussions even when he resorts to an increase in production, and the *sacrifices* may be inherent in the *definitive* payment of the tax; *f)* the taxpayer onto whom the burden of the tax has been transferred in addition to that collected by the tax tends to “*free himself*” of the fiscal *burden* by transferring the tribute onto others; *g)* there is shifting when “*an individual manages to transfer*” onto someone else the burden of the tax to be paid, in total or in part; *h)* if the tribute involves a considerable increase everyone will try to repel it; individuals *will search* for new relationships and an economic behaviour that will still ensure them maximum utility, having taken into account the intervention of the tax, etc.

This compilation of concepts is placed in a finalistic logic, in the approach to the problem of distribution, and in practice demonstrates the existence of *motives* or motivations of tributes that take the place of *causes* in inducing the subject to act in the sense of re-establishing or overtaking a condition a maximum utility, wellbeing or satisfaction expressed in hedonistic terms. The trend to this objective of return to the achievement or of overtaking a maximum in subjective and objective terms explains why a vision of the financial phenomenon has for some time led to the distinction of the following *moments* of the finalistic action mentioned above, in spite of the fact that the causal scheme has been adopted in an implicit and explicit way:

a) *Percussion* of the tax, which some consider to be painful even when only announced or when there is identification of the passive subject in a formal or legislative way; from this emerges the behaviour of the subject who tries to avoid the sacrifice that derives from the subtraction of a quantity of available, perceptible and obtainable income in a different way without the fiscal burden. This can be translated into an increase in costs or a reduction of income, as modes that the same subject may believe to be equivalent.

b) *Shifting, or repercussion* on the part of the subject charged: 1) immediately charged to another taxpayer; 2) or through a series of exchanges, through variations of relative reasons or of prices, charged indirectly to a third person who bears, finally, the subtraction of wealth corresponding to the collection carried out by the State or other public body authorised to carry out fiscal collections.

c) Incidence, which is the moment that characterises the painful state or the sacrifice that is expressed mainly in monetary terms, borne by the person who is unable to transfer the tribute further.

An additional specification of the circulation (for shifting) of the fiscal burden, before its incidence, has led to the differentiation of the following types of attempts or the sense or orientation of the behaviour of the subject to transfer the fiscal burden on third parties:

a) vertical progressive shifting (of which we have an example in the attempt of the producer of the taxed goods to pass the burden onto the consumer);

β) indirect progressive shifting (when the shifting, for example, passes from the producer of the taxed goods onto the consumer of goods *not affected* by the hypothesised tribute);

γ) regressive shifting (for example on the part of the producer of taxed goods to suppliers of factors necessary to the production of the same goods).

We do not insist on other conceptual specifications that do not even have the advantage of uniformity in the literature of the various States and which the same Seligman (to whom I refer the reader for English, French and German terminologies) considers “not very important”. According to tradition on this point, I will recall other circumstances, subsequent to that of (*c*) of the incidence.

d) Diffusion, indeed, has been defined as the consequence on the market of the behaviour of the affected taxpayer who limits for example current consumption in order to ensure more useful future ones (with reduction of prices, incomes and consumption for his suppliers); in other words, if the reaction of those who do not want to renounce the maximum satisfaction compatible with current income, reduced by the tax, consists in maintaining constant the actual consumption reducing savings *pro-rata*, the lesser offer of it will translate as an increase in the interest rate and in the cost of production of those who express a demand for these instrumental goods.

e) Removal (as a typically finalistic positive event) is defined as the reaction of the subject affected by a tax who tends to recuperate at least in part (this will be seen later) the condition of maximum enjoyment before the incidence. An increase in productive efforts, for example, can represent a mode of removing at least partially the fiscal burden that has removed from the subject the sum of income received or of satisfactions enjoyed before the incidence.

f) Amortization or *consolidation* of the tax is considered to be the moment that represents a mode of being of regressive shifting, according to some; it acts for example from the buyer towards the seller, in the sense that the first charges the second with the burden of an increase in the tax or of a new tax, capitalising the annual amount at the current interest rate. This is a trend, therefore, to obtain a set and current net income from the asset purchased.

Others suggest that this is a mode of being of diffusion as a consequence of the incidence already implemented or expected in the future.

g) Evasion is the moment when the subject, contravening the legislative command or modifying his own behaviour, without incurring a fiscal infraction, refuses to carry out instances of production, of consumption, etc., so tending to avoid the fiscal burden.

In presenting this catalogue of moments in which the modification of the behaviour of taxpayers, *individually* considered, is specified in a finalistic and voluntaristic context, it is necessary to admit that: *a)* either this behaviour has not taken into account (in the equilibrium between burdens and advantages, which derive from -the destination of public expenditure), the sum collected through taxation; *b)* or this equilibrium, taking into account the direct and indirect advantages of public expenditure, is negatively closed to the subject¹⁸⁴ so that he, for the double action of the collection and of the advantage achieved for the consumption of public services or for the utilisation of public expenditure, finds his condition of beneficiary of a maximum of objective utility or of subjective satisfactions pre-dating the interference of the overall financial event, worsened. *c)* the subject benefits from this to exceed the previously achieved maximum.

This is *not* the vision of the authors who introduced the sequence of moments in which the vision of the effects of taxes took shape, but we will talk about this later.

¹⁸⁴ See my position of 1931, which avoids the criticism (furthermore not shared by me) that many aim towards De Viti De Marco when he admits that “in pure theory it is necessary to say that it has been reduced”, referring to the cost of production following an increase in the levy (E. D'ALBERGO, “Giornale degli Economisti” [Economist Journal], December 1931).

C) In the meantime, by moving the order of the principles that were introduced in the *Introduction*, we will consider the vision of the effects of taxes in the deterministic logical context.

This point of view contrasts, generally, with the atomistic one, where the considered, or conscious and finalistic action of the subject (taxpayer) is at the centre of the close examination of the events provoked by the State in the collection and distribution of fiscal revenues, a typical and preeminent “constraint” in financial activity.

The real phenomenon that is implicitly present, in the deterministic logic, is that “of mass”, and affects the entire economic equilibrium. “Let’s consider a market, a community, a system, etc.”, is the expression with which Sensini opened the quoted essay. The influence of the introduction of the tax removes the system from the point of equilibrium, whose valid relationships we study, having hypothesised the State financial activity as a perturbing force.

A perturbation of the system, caused by an element, *must* appear gradually, through actions and reactions throughout the system, to use an expression by Cournot, to whom the merit of having first rigorously conceived the general interdependence, later notoriously arranged by Walras, is recognised.

However, the mathematical and mechanical concept of equilibrium in Walras does not deny the theoretical causal treatment method, which coexists and is compatible with the vision of functional interdependence. It is true that the vital law of the system of needs of the individual is still valid: it does however operate through a process of *adaptation* of the economic disposition of individuals at conditions (and prices) that are determined on the market that is also outside their voluntaristic deliberation.

This vision becomes more rigid in the concept of Pareto, who places his own model (in which exists a reciprocal interdependence) in contrast with that of theories that propose the research of “the cause” of phenomena. The theory of pure economy in the logical order of mutual dependence of the considered quantities gives a concise notion of economic equilibrium.

To pause at the exchange, including in regimes of competition, in the context of the atomistic and causal vision as in the finalistic one, occurs the circumstance that, in the new market conditions determined by the tax, through an adequate variation of the price, allows the subject as taxpayer to transfer and bring to bear onto third subjects the burden of the tax, freeing himself of it at least in part.

In the deterministic vision of the general and static economic equilibrium in regimes of free (perfect) competition, prices are considered as *given* and as constants for all exchange events, but the value of the different prices are unknown quantities: in this way individuals accept the existing market prices “*without making any attempt to influence them*”. Each subject will continue with partial subsequent exchanges of his own goods with those in demand until he reaches the point of equilibrium characterised by the generally recognised levelling of the exchanged portions of marginal utility. Of course in the exchange of several goods the supply and demand of each individual type of goods depend on the prices of all the others.

Having made these observations about accepted concepts, how does the distribution of the tax on the market work from this point of view? We can refer to the approach that is closer to the logic of this vision, as the study of the effects of the imposition generally or as analysis of the modification of the economic equilibrium due to the interference of the fiscal event, represented by the collection of quantities from individual budgets and the destination for different uses on the part of the State.

I consider Ricardo a forerunner of this position, as our academics have recognised, because of a passage in *Principii [Principles]* (which confirms in a more effective way the thought contained in *Risposta alle osservazioni del sig Bosanquet [A response to Mr Bosanquet's observations]* to which Cabiati made reference in the *Giornale degli Economisti [Economist Journal]* of November 1928, in reviewing De Viti De Marco’s “Finanza” [Finance]) in which I found this thought indicative of a logical order:

“If a tax of any extent is charged to income and not to capital it does not reduce demand but alters its nature. It allows the government to consume as much of the produce of the land and of labour as the individuals who contribute to taxes used to consume before. If my income is of 1,000 units per year and I have to pay 100 of them in tax (to the State) I cannot but demand nine-tenths of the quantity of goods that I used to consume before the tax. However, with the tenth that I pay, I

transfer to the State the power to demand the other tenth of goods. If the object taxed is wheat, it will not be necessary for my demand of wheat to decrease because I can come to terms with having to pay 100 units more per year so decreasing by the same quantity my expenditure on wine and other luxury goods. Less capital will be used in the production of wine and in that of moveable goods, but more will be used in the manufacture of those objects on which the taxes will be spent by the government". Other concepts that explain further this central idea of Ricardo's follow. These are ideas quite similar to those that U. Ricci has identified in *Principii di Canard [Canard's principles]* ("Revue d'Econ. Pol." [Political Economy Review], Paris, 1932).

Fasiani has found similar ideas in Messedaglia. Others have identified analogous visions abroad ¹⁸⁵ and I agree with Borgatta in believing that Wicksell [in spite of the fact that he partially contradicts himself (p. 64)], on p. 13 of the Italian shifting in the "Nuova Collana di Economisti" [New Economists Series], also had this view, even if less precisely expressed: "It is possible that the State, as consumer of goods and personal services, or as producer, exerts a certain influence on the remaining supply and demand and in this way also on the incidence of taxes". (The contradiction comes from the fact that, having stated this, Wicksell intends to disregard this expenditure or demand on the part of the State in the study of the effects of the imposition.)

However, the reference to De Viti De Marco is now systematic in the presentation of the effects of taxes (he says *of shifting*) in a model that is of deterministic type which is pertinent to the vision of the general economic equilibrium.

"It must always be presumed," (he writes on p. 120) "that a point of equilibrium has been reached before the tax, that is to say, a system of prices around which demand and offer for all types of goods are balanced."

"The problem of shifting consists in the investigation of whether the tax in itself, that is to say, in an abstract context with regard to other forces, modifies this equilibrium so as to produce an increase in some prices and reduction in some others. Because in this case there will always be shifting phenomena."

After a presentation of a Ricardian type, in other words in the sense of the passage quoted, on which we will have occasion to return, De Viti expresses some propositions that help us understand in which logical deterministic model he was operating, which we can define as being of Paretian type.

"The *immediate* and *necessary* effect of the tax is that it modifies the previous demand curves of private goods both for taxpayers and for the State. For this reason the new direction of the demand curve of taxpayers and of the State is the only necessary event that upsets the previous equilibrium. This implies variations in the previous systems of prices up or down, and therefore in all cases there will be shifting phenomena whether the tax affects equally all or only some of the citizens, or whether producers find themselves in conditions of monopoly or of free competition."

"The producers of goods (whose demand and price has increased) affect the tax, the others are subjected to it".

"Immediately, after this first period, comes a second period (that of the distribution of productive services) in order to *readjust* (my italics) the supply curves to the new demand curves."

"It is in this second moment that producers come into play, by increasing the offer of goods whose demand has increased and contracting the offer of those goods whose demand has gone down, reaching a new equilibrium characterised by the levelling of their profits."

This process towards a new equilibrium, or towards the return to the old equilibrium, is then examined by De Viti with reference to those he defines as "the two fundamental cases of value": that of free competition and that of monopoly.

We will have occasion to proceed, with more analytical and complex criteria, to the study that De Viti proposes on opposed market conditions. For now I am interested in observing how this vision – that I *oppose* to the finalistic and causal trend, that is to say, of the economic subject tending to act "because" of the tax and "in view" (motivation) of, or for, the aspiration to reach a condition of

¹⁸⁵ V. Signorelli reproduces significant passages from G. A. R. HELFERICH, in the monograph "*Problemi teorici sugli effetti dell'imposta in rapporto alla spesa pubblica*" [Theoretical problems about the effects of the levy with regard to public expenditure], Florence, Da Vita 1951.

maximum wellbeing (ophelimity or monetary utility) – confirms the deterministic model. In this, as has been seen, we can find the *adaptation* of individuals to the conditions that are *determined* in the market by the mutuality of relationships of dependency influenced by the complex financial event (collection and expenditure).

As I have underlined, it is De Viti De Marco who adopts the term “to readjust” with reference to producers who take into account curves of demand and undergo the prices of the demand. That is, they do not act on their own initiative to *increase* prices, as could be admissible in a finalistic or causal vision.

It is in these terms that the juxtaposition between the models that relate to shifting or, better and more coherently (in the case of the vision of economic equilibrium), the economic effects of the imposition and of the public expenditure, needs to be viewed.

This is all the more so as it is the very prince of the classics, Ricardo, who had a clear view of the modifications of the general equilibrium as a function of the complex financial phenomenon and in a deterministic sense, as has been seen in passages we have recalled, in the vision of the economic effects of taxes in a wider sense than the limited ones of incidence.

It is not by chance that I adopt the expression “economic effects of the imposition” in this second model and I do not refer to those moments (percussion, shifting or repercussion, incidence, diffusion, removal, etc.) of the imposition. De Viti De Marco, in spite of adhering to the deterministic model of the problem of economic equilibrium disturbed by the imposition, preserves the concepts relating to the above mentioned *moments* that, as has been seen, I have referred to as the causal and finalistic models, in an atomistic and not a mass context.

With reference specifically to “diffusion”, I observed, that, by adopting the deterministic model of economic equilibrium, it is not logical to refer to the instances that are compatible with the model based on the causality or finalistic principle. In particular, as it is an issue of *degree* of the modification or vibration of the economic equilibrium, it is already appropriate to conform with the concept of graduated effects (1st, 2nd, 3rd, etc. degree) of taxes.

This logical requirement that I express in this “course” does not refer only to De Viti De Marco’s vision, which can be considered to be indicative or typical of the deterministic point of view, but is also applicable to general Ricardian-type approaches of Wicksell, Messedaglia, Barone, Sensini, Borgatta and Dalton.

[In contrast, it is possible to define the adoption of terms that characterise the instances of atomistic reaction of individuals to the fiscal event that removes them from the maximum condition they tend to, according to the principles that explain their behaviour, considered in the previous paragraph, as being of Pantaleoni–Seligman type. This is so even if, as we will see, the first group of academics abandon the deterministic model because of methodology issues (in-depth analysis of specific problems).]

I have maintained, in the works I have just made general reference to (E. D'ALBERGO, *La funzione della banca e gli effetti economici dell'imposizione* [*The bank function and the economic effects of imposition*], “Rivista Bancaria” [Banking Review], 1936; *A proposito di “diffusione dell'imposta”* [*About the diffusion of taxes*], “Riv. di dir. Fin. e scienza delle finanze” [“Review of financial law and the science of finance”, 1937) that the “instance” of *diffusion* (like all those of the opposed atomistic model: *percussion*, etc.) is not logically compatible with the adoption of the deterministic model that synthetically envelops the entire phenomenon of the effects produced by the imposition.

From this latter point of view, of De Viti type, theoretically there is a variation of *all* curves of demand and supply, in compliance with the relationship of interdependence of economic quantities.

To briefly indicate the variations of demand determined by the interference of the State, which collects and spend one part of the wealth of a market, it can be said that the modifications have an influence on: 1) the curve representative of the (new) State demand; 2) those of private individuals who see their income grow because of the effect of greater demand of goods and services on the part of the State, if a marginal increment of the imposition (and expenditure) is hypothesised; 3) those of the suppliers to the latter; 4) those of the taxpayers who have essentially paid the State tax without being able to recoup it from third parties, because the (public and private) demand for their respective

goods and services has decreased and in consequence their corresponding incomes have similarly decreased; 5) those of private individuals who, as suppliers to the previous group, see their incomes decrease as a consequence of the restriction in private consumption, and so on.

The variations of the supply curves, responding to adjustments in the demand curves, will reflect the indicative variations of the demand curves as they are mutually linked. If we make the hypothesis (which in any case corresponds to the real event, excluding conflicts) of any simultaneous realisation of such variations in the curves of demand and supply, in consequence of the complex financial event, we find that they relate to percussion phenomena or announcement of percussion (effect observed by Pigou), shifting, incidence, diffusion and, generally speaking, the direct and indirect influences of collection and expenditure by the State.

Therefore we understand how logical the adoption of the term “effects of 1st, 2nd, 3rd ... degree” is, as being suitable in reflecting the deterministic vision which is, for one aspect (synthesis), closer to the real phenomenon. That is to say, the specification of the instance of the effects of the imposition in the previous paragraph does not correspond to the mass deterministic model that has been opposed to the atomistic one in the previous paragraph¹⁸⁶.

This vision of mine is not that which induced Einaudi to adopt the synthetic definition of the effects of taxes in the study focusing on the analysis, according to another model, of the repercussions of the types of tributes, drawn from reality.

¹⁸⁶ In fact it is possible to observe that:

1) one of the “processes of diffusion (and also of incidence) hypothesised about the levy, considered separately by other authors, is identified;

2) it is possible to understand, among the effects of diffusion (and also of incidence), hypotheses relevant to translation, as considered by Pantaleoni and his followers or the group of Ricardo (Mill), Messedaglia, Wicksell and De Viti De Marco. This transpires not only from the examples used by Griziotti to indicate cases of diffusion but also from the admission by the author, the result among other things of acute observations: it is possible to note phenomena of *repercussions of the effect of diffusion* also in the movements determined by the diffusion of levies, phenomena that Griziotti would like to keep separate from the processes of translation in the strict sense. Other authors, who believed that the general levy on income could be transferred through *phenomena of translation* that are “the effect of diffusion” of the same levy, were not able to avoid this confusion;

3) it is possible to believe that translation is a *possible* phenomenon that can occur only in determined conditions, whereas diffusion “is a necessarily consequential phenomenon to every levy”, as De Viti states without, in my view, a plausible reason. It is sufficient to consider the deterministic synthetic approach, more approximate for this real phenomenon, that De Viti De Marco and previous authors, who can be considered in the same order of ideas, to the process of “translation” of the levy to observe how it is a *necessary* event or inevitable *consequence of the disturbance* of the economic equilibrium due to the collection and distribution of the levy;

4) The confusion of the effects of the repercussion and of the incidence is expected by Fubini (*op. cit.*, part II, Chapter I; part V, Chapter V), who also admits the term “diffusion” in the meaning of the effect of incidence. In fact, the author, in subtle investigations, believes that the difference between translation and diffusion diminishes until disappearing: a) if account is taken of the fact that translation does not occur suddenly but only after a certain period of time has gone by and, in the meantime, the charged economy has also experienced incidence; and that (as people always act on the basis of future forecasts) diffusion is the consequence not necessarily of an already occurred incidence, but always of a forecast (or feared) future incidence; b) if diffusion is considered to be the effect of a reaction of demand and if the final compensation is considered in the long term, as an indication of the levy in all categories of market prices. This is a concept that I find similar to the approach to the problem that Wicksell and De Viti De Marco respectively define, concisely, as incidence and translation of the levy.

Therefore the current terms, including that of diffusion, do not appear to be correct even with regard to precision of coherence in the deterministic model in pure theory; I believe it to be convenient, not so much because of terminology concerns but for reasons of economic logic or the scientific point of view, to limit the indication of the repercussions of the increase or the introduction of the levy to Einaudi’s strict definition of *effects of the levy* with the addition of the specification of *degree* that appears in the text.

III.

LOGICAL NECESSITY OF THE SIMULTANEOUS OR COORDINATED STUDY OF THE EFFECTS OF COLLECTION AND EXPENDITURE OF TAXES

I) Incidentally, there has been reference to the simultaneity or the necessary occurrence of two events that inevitably modify the economic equilibrium, in an intuitive way.

It is an idea that goes back to Canard, if I am not mistaken [but this opinion is compared with that of U. Ricci who has analysed the *Principii [Principles]*, (*op. cit.*) with due diligence], who saw the modification of the economic equilibrium through the redistribution of uses through the entire market due to the financial event or for the search for a level of profits on the part of producers that was not charged by the tax; he, however, expressed this unconsciously when, as I have recalled, he saw the modification of demand and supply following the collection and distribution of tributes.

This is the idea that, as has been seen, was later clearly expressed by Ricardo and developed by other authors and in particular by De Viti De Marco to whom we have previously made reference.

I warned, in the 1944 lessons – and the idea was approved for example by Borgatta, who in 1945 included this idea in the treatment of war finance – that it is an approach *analogous* to the Ricardian one and not identical to that of De Viti De Marco. This author restricts its scope when he states that “in no case the immediate effect of the tax is to modify the pre-existing supply of goods”, adding that the State will come to the market to demand *goods different* from those that taxpayers demanded before the tax. “If they employed 10% of their income in purchases of cloth, food and manual work, the State will employ it for example in purchasing iron, arms and intellectual labour”. The concept is further defined with the words: “It is indifferent whether the State spends the tax well or badly, but it is necessary or sufficient that it spends it differently from the way taxpayers used to spend it”.

In Ricardo we find the admission of the possibility that the State consumes *the same* goods that taxpayers consumed before the tax. However the *use* of goods would be different, in as much as they would be *destined* for consumption by the *State* and no longer by private individuals. If the practical example is not in contrast with his thinking, that is if the supply of wheat on the market remains the same, one part can be subtracted from private demand and transferred to the State, which will use it to feed troops for military defence. In this case there is demand for the same goods that were previously consumed by private individuals, but it is destined for public use because consumed by subjects who satisfy, through the State organisation, a public need. In the historical case it has happened that, in the wheat example, the consumption was transferred to people (soldiers) who, when they were private consumers, did not consume it or consumed it in different proportions, using substitute goods in the previous period. This can be said of other goods similar or the same as those that private individuals consumed before the tax and that the State, through its agencies, consumes after the collection of the tax.

Only a wide and perhaps arbitrary interpretation of the last expressions quoted above for De Viti De Marco (it being “necessary and sufficient that the State spends in a different way from taxpayers”) could help identify in the *diversity of expenditure* a *divergence of use* in the *same goods* as well as the *qualitative* differentiation of the goods object of new curves of demand. Indeed, the reason for which De Viti De Marco probably underlined the diversity of the object of demand consists in keeping in mind that there will be a *specialisation* in the *action* of private individuals and in that of the State, in the *division of labour* between *private* and *public*, which would not arise if it were identical to the previous action of private individuals and before the State intervention. However, I fear I have gone beyond De Viti’s argument.

Ricardo must have considered the issue from this conventional aspect, in the course of his *analysis*, having already demonstrated to have full vision of the variations of the economic equilibrium due to the fiscal event, as synthesis, when he separated the study of the effects of the collection from that of the effects of public expenditure.

However, the *logical necessity* of the theoretical examination of the simultaneity of the occurrence of the two aspects of the phenomenon *does not fail from any point of view* from which the phenomenon, complex in itself, is explained.

Indeed, we have made the premise that an atomistic vision of the phenomenon may give an explanation from the causal or the finalistic point of view. The taxpayer, “because” of the collection – which can be considered to be equivalent to an increase in his costs or a reduction of the resulting utility of his own activity – would react by attempting shifting. In another sense, as the tax translates in circumstances in which the subject is removed from a condition of objective (monetary) or subjective (in terms of utility) maximum, he would tend to preserve this condition of maximum or to return to it: he would aspire to transfer onto others the burden of the tribute, perhaps exceeding this given maximum.

However the hypothesis that this behaviour of the taxed subject is in relation *only* to the fiscal collection (or the simple announcement of the collection) could explain the *impulses* but not the rational behaviour, which is of interest here, of a subject; it could refer to, if anything (introducing the time factor), the effects of a *first period*, contrasted with the effects of a second period (that is to say, when the effects of the public expenditure on services offered to the community and enjoyed also by the individual are perceived by the same individual).

Generally speaking the *hedonist*, who as such coherently performs such *logical* actions only when the equilibrium of costs and advantages, of sacrifices and utilities gives by hypothesis a negative balance so reducing incomes and pleasures, will tend to (causal and finalistic explanation) to transfer the tribute, if circumstances allow it, as I have stated since 1931.

Generally speaking, therefore, a comprehensive explanation of the rational behaviour of the hedonist, even though individually considered, cannot logically overlook an integral close examination of the phenomenon.

Only by reasoning in a first approximation to the reality or to phenomena of a first instance and for convenience of analysis, is it possible to restrict the examination to that which would be, from a causal and finalistic point of view, the conduct or behaviour of the subject affected by the imposition.

For over 20 years, dealing with the economic effects of “taxes on exchanges” (“Giornale degli Economisti” [Economist Journal], dec. 1931, *op. cit.*), even though I did come to agree with the juridical concept of “cause” of the obligation of the tax that Griziotti wrote about, I have developed the realisation of the importance that can be associated with the advantages deriving from the financial event. I did not do so in the terms that the author had chosen: these advantages are the practical “purpose” of the contribution and the economic and juridical reason for which the taxpayer adapts or desires to be part of the (public) association.

Conversely – more in a finalistic rather than causal sense – once this point of view is recalled to demonstrate the *rationality* of the taxpayer’s behaviour in the shifting of tributes, I also wrote, still anticipating the vision of the financial phenomenon that has dominated my lessons since 1932 (*Intorno al concetto di costo dell’attività finanziaria [On the concept of cost of financial activity]*, *cit.*) what follows: “When we proceed with an increase in the tax, the subject who decides on the increase of the tax is the State; this is also the case with the introduction of a new tax. When this evaluation,” – I stated on that occasion – “coincides with that of the affected taxpayers, it can be theoretically said that the tax causes the cost of production to decrease (it can leave it unchanged), while it causes it to increase when the State collects the tax and this does not represent for individuals the price that they would have freely paid in compensation of services that, in their view, facilitate the production activity.” This suggests the presumed depth of the hypothesised *rationality* of presumptions on the equilibrium of hedonistic and economic quantities (productive activity is economic activity in the wider sense, differently defined to continue on the theme of the concept of cost of production) that finalistically induce the taxpayer’s behaviour to shifting, in the sense that has been here further clarified.

Therefore, from the atomistic point of view, using the principles of causality and finalism to explain economic action, an investigation that claims to approximate the real event cannot, without contradiction with facts, disregard the consideration of the effect of public expenditure as well. The

admission by Cournot, who explained the rational behaviour of the monopolist tending to defend his position as subject who has reached the condition of maximum monetary utility before the tax, is significant from this point of view. Indeed, the illustrious author, in defining the limits of his investigation, stated: “We will not examine here the effects of such a collection on the distribution of products of nature and of labour, even though this is the final object of the problems that relate to the theory of wealth”.

If this is true in the case of the atomistic model illustrated earlier, then the discussion is even more idle and mistaken when we claim to observe, as it has patiently been hypothesised by some (for example Fasiani, in “Studi in memoria di G. Masci” [Studies in memory of G. Masci], Da Empoli and others) that it is legitimate to disregard the effects of public expenditure even though the research investigates the overall mass phenomenon.

Indeed, as soon as the proposition is stated that “*the State modifies the economic equilibrium with his own activity*”, it is deemed not to be permissible – in the context of coherent and logical argument – to hypothesise that only the effects of the fiscal collection on the same equilibrium are examined.

Meanwhile, the reference to the economic equilibrium cannot be traced only in those works whose authors have intended to make reference to the few quantities that appear in the model of the specific cases of equilibrium in the Marshall model, but also in many works that explicitly or implicitly make reference to the general equilibrium.

Having expressed this concept of the adhesion to the theoretical Walras–Pareto model, we adopt it because “embracing simultaneously all the essential factors in the economic world shows their interdependence”. I wanted to refer to an authentic interpretation of Pareto, in which we don’t consider, as is right, *all* events but only the essential ones. No one will want to attempt to demonstrate that distributions of the purchasing power collected by the State are not essential when we think not only of the importance of public revenues with respect to private wealth, in particular in terms of income flow for communities, but also about the circumstances whereby public services are instrumental for production and for enjoyment of wealth, as will be recalled later, in dealing with the individual issues and as was noted in the *Introduction*.

However, in principle, the adoption of the deterministic model, with the specific reference to the general economic equilibrium presumed to be disturbed by the State activity in this field, which is very frequent in financial theory, requires for reason of logical coherence that *all* essential factors of the equilibrium are taken into consideration.

Barone, also an interpreter of the Pareto model, confirms that “essentially, in its wider generality, the problem of shifting is the problem of variation of *all* (my italics) the economic quantities of the equilibrium under the effect of the tax”. The thesis that I am supporting here in a theoretical way finds confirmation in Barone’s work. At a first glance it would appear that he refers only to collection, in consideration of the term used (*Principii [Principles], op. cit.*, p. 271). However, immediately after (see: note of p. 276 and p. 280) he specifies, in the logical trail of Ricardo, De Viti, etc.: “... the event of the tax, if it decreases the demand of products for individuals, it does also determine an increase in the products of the body that receives the tax, etc.”. This is equivalent to saying that public expenditure is an essential factor of the equilibrium to explain how *overall*, for example, production has not decreased but how it may even be stimulated by the tax.

Even though he wanted to differentiate between the problems relating to the “first phase” of the variations of the equilibrium and the problems of definitive permanent equilibrium (second phase), Borgatta (in *Appunti [Notes]*, Giuffrè, 1933) specifies: “While with the first it is possible to take into account only the most direct economic repercussions, in the study of the second it is not possible to disregard the effects produced by the use of the tax on the part of the public body”. (He quotes, for example, the essential and not occasional case of the repercussions of the general tax on interests from capitals).

This is why Borgatta has been incorrectly quoted, ascribing logical difficulties opposing the rationality of the approach to the financial problem in terms of study of the repercussions of collection and expenditure. Indeed, in later works, as I have demonstrated elsewhere (E. D’ALBERGO, *Effetti delle imposte e teorie del full employment [Effects of taxes and theories of full employment]*, in

“Economia Internazionale” [International Economy], 1948), differentiating between the problems of *conception* and problems of *verification of quantities*, as I continue to do in these lessons, I have specified that Borgatta intended to refer to difficulties of a practical and statistical nature in identifying destinations of tributes and assignments of specific effects to collections and expenditure of tributes with this technical-logical expression, correcting the mistaken views of another author who would have liked to re-evaluate the restrictive clause of the “hailstorm tax”.

Generally speaking, still remaining in the field of logical concept, I have always thought it necessary to consider the revenue of the expenditure of tributes in respect of the interpretation of the real phenomenon, even if ideally.

Pareto warns (*Manuale [Manual]*, p. 143) that objective events are very numerous and they are in part interdependent. To simplify the problem he suggests its reduction, as has been seen, to the main and essential elements. However, I do not believe that in the specific case another follower of the illustrious Sensini (*op. cit.*) has remained faithful to the rationalistic spirit of the Paretian model, when he referred to the economic system, the market overall (mass phenomenon), but disregarding the effects of public expenditure. This is so in the context of a general approach to the problem of the effects of the imposition, in the interpretation, that in the sense of *extension* is closer to reality because it is *synthetic*, of theoretical visions that allow us to deal with only one part of the complex problem, that in reality is not disregarded. The true spirit of the Paretian model can be found in De Viti De Marco, not formally a mathematician but someone with a coherent and wide viewpoint which eludes those who use mathematics as symbolic demonstration.

In one word: returning to the deterministic principle (and in macrodynamic terms also to the probabilistic one) becomes contradictory in terms of the explanation of the financial phenomenon, by first putting forward the model of a general economic equilibrium model characterised by functional interdependence and then curtailing this approach by disregarding the essential element of public expenditure in the theoretical close examination.

In the field of rational thought, therefore, the not-yet-resolved discussion regarding the logical legitimacy of eliminating from the study of the complex phenomenon the simultaneous analysis of the effects of the collection of the expenditure on the part of the State does not deserve to be taken into consideration.

The issue of the *convenient* hypothesis of study that, as we will see, can lead to a simplification of the problem, reaching partial and provisional solutions, is something else completely.

The simplification can consist of: 1) disregarding the effects of expenditure; 2) treating separately two aspects of the same single problem of the variations that the financial activity determines on the economic equilibrium.

Whatever extension is applied to the vision of the variations that are determined on the market, it is necessary to state that, in any case, the deterministic model remains a comprehensive way of interpreting the phenomenon. To return to the example of wheat, even admitting that the State demands the same quantity that private individuals demanded before its interference, the fact that their *use* is different, that the wheat is used to feed a *specific amount* of work applied to private production or that *the same quantity* is destined for work used in the production of public services, *is not insignificant* in terms of the repercussions on the economic equilibrium.

This was not perceived by those who would like to argue the logical legitimacy of the *refusal* to closely examine the effects of public expenditure, from the point of view of the hypothesis of the coincidence of demand of the same goods on the part of private individuals (before the collection of the tax charged to them) and on the part of the State (using this revenue). To highlight at a glance the fallacy of this argument, let's consider only the different instrumentality of public services, the different attitude of those who benefit from the purchasing power redistributed by the State, in terms of consumption, savings, etc. (also according to the meaning of the Keynesian-type “propensities” that characterise hedonistic trends of subjects, a concept that has been applied also to the problems of theoretical finance for some time).

Generally speaking, we cannot agree here with those who doubt the logical necessity of considering both the effects of the fiscal collection and those of the distribution of that revenue when

they presume that the financial activity has modified the economic equilibrium, so implying a contradiction of terms.

These are often idle, even if not incorrect, discussions on the logical legitimacy of the introduction of what has been defined as the hypothesis of the “hailstorm tax”. This is a flexible definition, at first glance univocally expressed by Einaudi in the sense that “the tax, like hail, takes away from men the fruits of the land, without cost and without reward”.

However, I can bear witness with regard to the misunderstanding determined by this formula in my experience, in the sense that some authors have understood it, *not* because the effects of the destination of the revenue on the part of the state have been disregarded, but in the sense that a negative conclusion has been reached, that is to say, in the sense that the historical verification or the hypothesis of pure logic that, having carried out the imposition, has been resolved in the destruction or decrease of wealth, in contrast with the hypothesis of the lack of collection and the lack of public expenditure.

The hypothesis that the collection of taxes represents a net loss for society is an error if we pretend to consider true the mistaken statement of physiocratic origin, that State functions are resolved in activity that does not produce utility. This concept has by now been overtaken by the evolution of the theory.

The view that the tax is in any case resolved in an increase in the cost of production can be similarly incorrect, if one does not explain that in this case public spending does not bring any advantage. This can be admitted, in other words, as a *definitive* result or the algebraic sum of negative (collection) or positive (advantages of expenditure) effects with regard to individual taxpayers, both in terms of objective and monetary terms or in subjective utility terms.

Indeed, it is only as a *study hypothesis* that the tax can be considered an increase in cost. This does not mean it is a mistake but this requires the integration of further analyses to approximate reality or to comply with the concept of economic equilibrium, with the inevitable close examination of the effects of public expenditure, to reach conclusions of further approximations to a complex reality, adopting the comprehensive model used.

II) All that precedes leads now to further specifying of the concept of incidence of taxes, through a process of shifting.

With incidence we define the burden that is the real, final burden that reduces the income, profit, capital value, etc., of a component of the community.

It is not logically possible to know this position of the affected individuals if we do not consider the process of shifting in its entirety, as has been previously specified. State collection and expenditure, corresponding temporary burdens and advantages must be taken into consideration to complete the calculation of the final incidence, charged to individuals or groups of subjects. Jannaccone suggested this, anticipating nearly half a century of discussions regarding this issue (“Riforma Sociale” [Social Reform], 1902). It is logically necessary to proceed to an overall equilibrium through a comparison between two instances: *a)* the one before taxation; *b)* the one after.

This clarification is needed because it is necessary to differentiate between shifting (through the exchange and the connected variation of balancing price) of the *amount* of the tax, as formally or juridically conceived, as proportional to a quantity (income from perfect or imperfect competition, total or partial monopoly, etc., goods produced and sold, services supplied, capital owned or ceded, etc.), and repercussion – even after this given amount fixed by the hypothetical fiscal law has been translated – as variation of quantities that are used in the economic calculation of the subject chosen as owing the tribute. It is essentially the position of the *beneficiary of income*, the subject that could obtain, consume, etc., a certain income at the point before the imposition and the point after it, that essentially decides the effective or real incidence of the tax.

We will see later (for example, for a producer of goods subject to a tax proportional to the quantities produced, such as sugar), the fact that the tax can be entirely shifted onto the consumers, through the increase of the selling price, exactly as the amount of the tax. However, if this shifting of the amount proportional to the sold quantities takes place for a *lesser quantity* than that which had been fixed by the entrepreneur on the basis of a given industrial productivity before taxation of the product (proportional to the quantity sold), the producer will perceive a *loss of profit* or of normal

utility. This tells us that he is not indifferent with regard to what De Viti De Marco strangely considered a simple “accounting reimbursement”. Indeed, in addition to examining if and to what extent the tax is charged to the consumer, through a variation of the reason of exchange as a function of the amount of the same tax, it is necessary to know the repercussions on costs and on other aspects of the pre-existing productive combination, to determine burdens for the enterprise determined by the type of imposition presumed. As it is a matter of burdens in terms of lower income or utility or profit, to have an overall equilibrium it is necessary to know also the possible use of public expenditure on the part of the same enterprise (for example, in the specific case, through the distribution of public expenditure in production premiums in favour of the industry whose product is taxed, in view of the imposition on the income of consumers, as a means of a process of shifting).

Returning to logical points of views or principles in light of which I have introduced the shifting process (causal and finalistic on the one hand, and deterministic on the other), it is necessary to say that:

A) The subjects in the trend to act “because” of the imposition or “with a view to” neutralising its effects to return to the presumed condition of maximum utility or maximum satisfaction achieved *before* the tax, or advantages reclaimed by the new circumstances created also by public expenditure, that could lead to the exceeding of the maximum condition already mentioned, should take into account not only the amount of the tax but the other effects that ultimately the fiscal event can bring. This scope of research is coherently compatible with the hedonistic premises that induce action (in this case, shifting) from the point of view of the causes or the motivations that direct the rational behaviour of subjects who act in the market (atomistic view on the basis of the causal or finalistic principle).

From this point of view it is not possible to admit discussion on the logical necessity or legitimacy of the simultaneous consideration of collections and expenditure in the financial field; both “instances” can create advantages and burdens, greater or lesser costs, respectively, in terms of utility.

B) From the deterministic point of view it is necessary to ascertain what are, ultimately, the variations of economic quantities that put forward modifications of the condition in which subjects hypothetically were before collection and expenditure of the tax modified the *market* conditions (non-atomistic but *mass* view) with: a) the redistribution of the purchasing power performed by the State and with the *adaptations* of the supply to the variations of demand necessarily determined by the fiscal interference; b) and with the modification of the profitability of productive processes and hedonistic conditions of consumers.

This second (deterministic) principle coherently guides the entire research, allowing us to carry it out in the sense of the extension of the process that eventually corresponds in this comprehensive sense to the complexity of the real phenomenon, even though in the context of the *pronunciation of* or of rational approach to the entire process.

On the other hand, in the field of the study of the effects of taxes in which the causal and finalistic principles dominate, it is traditionally presumed that, in the matter of shifting, subjects individually tend to or are induced to transfer the *amount* of the tax onto third parties, probably *assuming* that it is transformed into a factor of reduction of profits and utility. In this way, because of an inadequate but very widely used study hypothesis, the equilibrium of advantages and burdens of the imposition is often *not reviewed*, which also disregards the destination of the revenue of the tribute on the part of the State.

IV.

COMPARISON OF THE TWO MODELS IN QUANTITATIVE TERMS

To focus the attention of the reader on simple graphics that contribute to the clarification of both pure and simple study hypotheses and the idea of the comparison of models (respectively, atomistic and mass or market ones) in compliance with logical principles that guide the investigation

(causal and finalistic on the one hand and deterministic on the other), I will give a general geometric and quantitative illustration.

I) From the first point of view, *A*), furthermore admitting that the tax, for the *single fact* of collection, is resolved in an increase in costs of production or in the decrease of utility of taxpayers in the role for example of entrepreneurs, these latter tend to transfer it onto third subjects, linked to the first by an exchange relationship. If we take the hypothesis of a tax proportional to produced quantities, we imagine it to be resolved (as we think in a first approximation, or without examining the problems overall as specified above) in an increase in the cost of production, presumed to be increasing, CC' , so that it increases by the amount of the tax tP' ; this variation can be presumed, because of the effects of the quantity offered, to be equivalent to a lowering of demand DD' to level dd' , with price tQ' net of the tax tP' . There will therefore be a contraction of the quantity produced from OQ to OQ' ; the price will rise from PQ to $P'Q'$; the producer limits the loss of profit or of revenue to the difference between the two triangles PCM and $P'cN$; in the hypothesis of equivalence put forward above (of increase in cost or reduction of demand and of the price net of the tax) this ($P'cN$) should be equal to triangle tCe . There would be a loss equal to $Pps - Csk$ in the case of an unchanged supply, with the entire tax charged to the taxpayer who does not react to it. The consumer bears, in part, the burden of the tax because the demand curve DD' allows the taxpayer to tend to reverse the increase in cost onto the consumer, but not all of it. In fact:



Figura 23.

the presumed trend of the demand curve does indeed allow the price to increase, but by $t'P'$, that is to say, less than the amount tP' of the tax. The consumer purchases a lesser quantity (OQ' less than OQ) and sees his income (as consumer) reduced from DPM a $DP'N$. The State collects the amount $tP'Ne$, whose destination is disregarded by many academics in the atomistic model, at the very same time when it would be necessary to take it into account to be able to determine from a theoretical point of view if the reduction of utility ($PCM - p'cN$), which has for example the nature of income in imperfect competition hypotheses, is to be considered a *real* or *definitive* burden. Similarly it cannot be said if the reduction in consumer satisfaction (loss of income, as such) is definitive if it is not known what use is made of the part of purchasing power that has been removed from the consumer, who has felt the partial incidence charged to him in terms of higher price, lesser quantity

purchased and the corresponding lesser income expressed hedonistically in the sense of less satisfaction felt by the consumer purchasing the goods.

These points are sufficient to help us understand how it is possible to admit that the fiscal event can influence, as in the geometrical example, the behaviour of producer and consumer in this case and generally of subjects linked to each other by exchange relationships, who are influenced *only* by the collection of the tribute just as a *provisional hypothesis*, in other words for convenience of *study* or as a *first approximation*. Even when remaining in the limited atomistic field of individual taxpayers who obey the hedonistic conscience imperative, moved by causes and motivations, it is necessary to complete the model by taking into account the use that the State makes of the revenue that here is equivalent to $tP'Ne$.

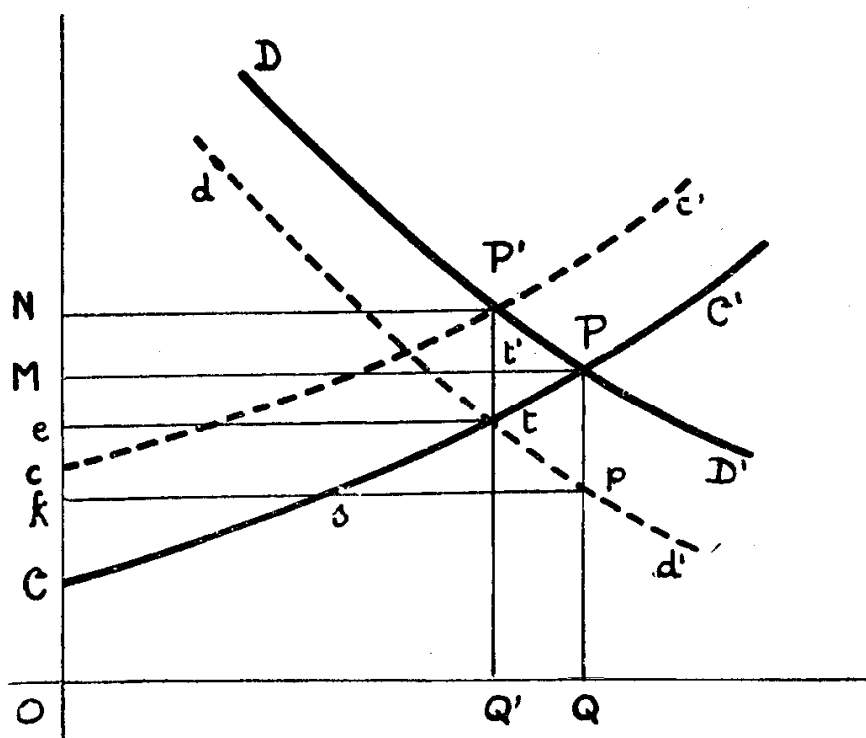
The migration of producers from the taxed field to others that are not taxed *or taxed less*, not the transfer of invested capitals, according to Seligman (who based this on the hypotheses that suggest that the tax is translated in an increase in the cost of production), would take place because of the partial tax that producers try to compensate for by increasing the price: the production of goods would decrease because not all producers would be able to do this, as some of them would be at the margin, when the supposition of the rigid demand or of demand without any degree of elasticity, or because profits are reduced.

What would happen in this incomplete model of reality is the result of the *definition* of value (price here) in the classics, who identify it with the cost of production, more than as the consequence of a barely approximate view of it. It is not possible to conceive a price unable to compensate for the higher cost due to the tax. From this derives the redistribution or the transfer of producers from one field of production to another, because of the intervention of a tax that is not applied to all production areas. Indeed, the attention of the classics focused on the supply, given the definition of value determined by the cost of production.

On the other hand, the redistribution of capitals and initiatives among the various industries and in general among the various forms of activity in the model that considers also the modification of demand curves takes place because of the supply adjustments determined by the interference of the financial activity that regards collections and public expenditure. As can be seen, entrepreneurs can *abandon* production sectors that are not of interest to the new or additional State demand or that lose the interest of private demand following a financial intervention by the State; vice versa, others can *come* to those sectors of activity on which the purchasing power indirectly redistributed by the same State activity concentrates, directly or through modifications of the utility and demand curves of private individuals.

However, the two *modes of creating changes* of use of capitals and labour that are in contrast here correspond to two different theoretical points of view. Of these, the first is focused on the definition of value influenced by the offer and, with this premise, on the *trend* of subjects to free themselves from the negative event of causal order (increase in the cost of production) that, as such, reduces normal utility, income or profit that are presumed to be at maximum level before the introduction of the tax.

The second, more relevant to reality in the sense that its *extension* is embraced by a wider view which considers variations of the general economic equilibrium, logically introduces the adjustments to the supply in terms of the conditions of demand created by the overall State activity. From this derives the influx of new initiatives and additional uses, and the outflow of existing initiatives and uses from sectors that are neglected by the above mentioned economic forces, put in motion by the State interference.

Therefore the redistribution of capitals, as seen by the classics, cannot therefore be criticised in itself, but for the limited reason that would have determined it, according to the theorists of value, that is to say only for the fiscal collection. On the other hand, wider hypothetical modern admissions explain and legitimise the redistribution of use in function of reduced profits that are reduced and increased by the financial event.

II) I will therefore move on to graphically outline the approach that, in contrast, is much more suitable in explaining the phenomenon according to the deterministic model that theoretically

embraces *all* the variations created on the market by the financial activity in its complex vision of collection and expenditure of fiscal revenue.

To give an approximate idea of the sense in which the entire phenomenon of the effects of the imposition on the economic equilibrium should be considered, limiting myself to two types of goods and two corresponding types of exchange and presuming then the argument to be able to be extended to the *entire market*, I propose a geometrically simplified view of the problem to compare the two models. It is sufficient, indeed, to use the distribution of the sum collected by the State to translate graphically and clearly, at least in part, the sense of the arguments of De Viti's type that have been described earlier, hypothesising that the taxpayer *adapts* to the variations of economic circumstances that are necessarily *determined* for the modification of the quantitative relationships already in balance before the complex fiscal event.

Let's repeat, more or less, the argument presented in the preceding case, presuming that it applies with regard to goods *A*. What we need to add here is the consideration of the destination of the quantity of purchasing power equivalent to $tP'Nc$ in the hypothesis that the State does *not* purchase the same goods *A*.

[We have generally stated previously that, even purchasing the same goods that would have been purchased by private individuals before the imposition, the State can coherently replace its own activity in relation to that of private individuals with a different *use* of the *same* goods. If the State purchases the *same* goods (in example *A*), we not only demonstrate, as I have done before, that in any case the economic equilibrium is not the same one that exists before the tax, but also that the utility of producer *A* can be similar to that which existed before the imposition or is even superior to it and in any case is greater than that which was presumed to derive from the preceding hypothesis, which did not consider the distribution of the revenue on the part of the State. For this demonstration, which is in any case intuitive and obvious, I refer the reader to Borgatta (*Finanza della guerra [War finance]*, *op. cit.*). For now it is important to be able to state that, by limiting ourselves to the approach that disregards the destination of the revenue of the tax and presuming that the subject is motivated to act by the causal factor represented by the decrease of utility or the increase in cost of production, in which *only* the fiscal collection is considered, the solution of the problem *does not indicate the real burden* or the *final burden*.

In a deterministic context, as has been said, it is not legitimate even as a hypothesis of study (as it is in contrast with the definition of economic equilibrium, presumed to be disturbed by the tribute) to imagine that the problem is resolved in the close examination of the distribution of *only* the burden due to the collection of tributes, even though Sensini for example, as I have recalled, has traced the equation of the system influenced only by the previously mentioned event.

To give an initial idea of the *sense* in which the problem of the economic effects of the imposition on the general economic equilibrium is examined and is solved, in a static context or disregarding the temporal succession of phenomena, we go back to the first vision and we make it more complex by presuming that the sum $etP'N$, collected by the State, is distributed in the purchase of another type of goods, for example, *B*.

This is equivalent to presuming that the demand curve for *B* is raised with respect to the previous one for private demand, because new purchasing power allows us to believe that higher prices for product *B*, hypothesised as an object of supplementary (State) demand, are acceptable *on the market*. Let's admit that the private demand for goods *B* does not decrease, as we can believe it to be the case for demand for goods *C*, *D*, *E*, *F*, etc., that are offered simultaneously on the market, to be modified in consequence of the tax collected on goods *A*, for the *necessary* modification of the replacement relationships that link them.

Let's admit that the private demand for goods *B* does not decrease, as the consequence that the demand for goods *C*, *D*, *E*, *F*, etc., does not change in consequence of the tax collected on goods *A*. This happens as a consequence of the *necessary* modification of rates of substitution between goods.

The quantity of product *B*, which in a *supplementary* way the State purchases, depends on the purchasing power equivalent to area $etP'N$ that can be transferred from *A* to that of $rsvzwh$ in the diagram that indicates what affects product *B*: that is to say, it must be assumed that the State

expenditure geometrically expressed in area $rsvzwh$ is equivalent to that of $etP'N$ that expresses the revenue of taxation of product A .

In spite of what could be admitted by limiting our consideration only to the fiscal collection, the tax (which for private individuals may result in the reduction of quantity offered and prices net of the tax - for example tt' ; and in the reduction of profits or incomes of some subjects) is necessarily transformed into the following effects:



Figura 24.

a) increase of price from wh to Zv for private individuals, net of the tax (which is presumed not to affect product B , for simplification); *b*) increase of the quantity of B offered from Ow to Oz ; *c*) increase of the producer's utility (normal profit or income, according to the conditions of perfect competition, monopoly or imperfect competition, etc.) from ghr to gvs .

In other words, considering simultaneously collection and expenditure of the tax, we can start to identify, in the redistribution of demand and supply of private individuals and the State, multiple effects that are clearly even more complex when we consider further degrees of shifting such as variations of the economic equilibrium that includes n products and *not only two* (A and B) that we have isolated in order to translate the preceding arguments in the models guided by contrasting logical principles into visible diagrammatic elements.

As stated in the *Introduction*, of course, in the case of the supply, the concise equation that refers implicitly to n goods:

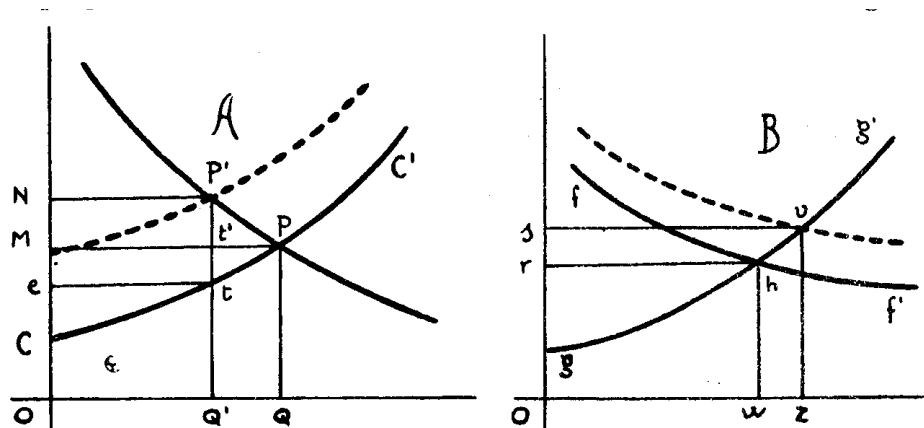
$$p_a + \Delta p_a = T + c_a(p_c + \Delta p_c) + L_a(p_l + \Delta p_l)$$

is useful in suggesting *all* the variations in the field of supply or production, in the overall market, that will take place when we presume the interference of the fiscal factor T that here we extensively believe to be able to interpret as having as object both the logical phase of the collection and that of the distribution of the tribute.

More complex algebraic expressions of the type used by Sensini (which in any case did not include variations of value of the elements of the economic equilibrium also in function of the fiscal expenditure) are useful in determining *all* the variations of quantity of prices, of net utility, etc., on the market and of verifying the actual, real and definitive distribution of taxes among the subjects that make up the community, according to the sense that has geometrically been given them, in brief.

V.

EXPLANATION OF THE CURRENT SIMPLIFICATIONS OF THE STUDY OF THE
EFFECTS OF TAXES

Having come to this point, it is necessary to refer to the juxtaposition incidentally indicated on the mode of getting closer to reality given that, as idealised and simplified, hypothetical events are always the object of science, as illustrated in the *Introduction*.

Indeed, it is possible to get closer to the reality of a static or photographic image of reality by using a comprehensive general model, suitable to encompassing the reality that is of interest to us, the entire market, a typical economic system. From this point of view there is no more coherent criterion with which to approach the problem than that which is offered by the concept of general economic equilibrium.

The extensive use of the spirit of this model by De Viti De Marco and earlier or later authors for the study of the financial phenomenon deserves great appreciation. With regard to pure economy, the so-called “immortal” concept (U. Ricci) of the economic equilibrium and the interdependence between quantities within it linked to others by constraints, which others (for example J. Fisher) has believed to be comparable to Newton’s universal gravitation concept, has received great recognition by Walras (and later by Pareto).

This was such that the criticisms and observations that have been aimed at De Viti’s treatise (by Fubini, Fasiani, Clark, etc.), when they were appropriate and interesting, can be considered either as clarifications or as interesting detail on the construction of the columns of the logical building that started, as I have recalled, with the intuitions of Canard, Ricardo and other forerunners of our master.

Although the Walras–Pareto model is mainly *static*, there is no denying the great merit of allowing a rational and extensive overall view needs to be recognised. However, the same Italian followers of the economic equilibrium model, from Barone to Borgatta, have considered the study of the effects of the imposition as a problem of economic *dynamics*.

“The tax represents a variation, in other words an intervention of *new* conditions in a given economic system”. “... A rigorous treatment of the problem of the effects of taxes could only be carried out using general laws of economic dynamics”. “... They should consist of the differences present in the equations of final equilibrium (which is reached when all the direct and indirect repercussions to which a tribute is susceptible have taken place) with regard to the initial one (such as it existed before the application of the tax).”

This was what Borgatta explained to his students in *Appunti [Notes]* (in 1933) and so he confirmed (in 1939, in *Studi in onore di G. Pacchioni [Studies in honour of G. Pacchioni]*, Giuffrè, referring to his *Economia dinamica [Dynamic economy]*, of 1915), specifying that in the definition of *new* economic equilibrium, “it is necessary to take into account the transformation that the wealth collected with the tax undergoes, through the destination of public goods and services and the effects that in this way it produces on private wealth and on the national income”.

Similarly Barone (*Principii [Principles]*, *op. cit.*), who has also produced admirable treatises on the model of general economic equilibrium, as I have recalled, has admitted that “in its wider generality, the problem of shifting is a problem of the variations of *all* the quantities of the economic equilibrium”, after having classified the same problem as one “of economic dynamics”: “it is a matter of investigating a new equilibrium when the existing one is altered by a tax”.

However, both followers of the Walras–Pareto model abandoned it when moving on to the *analysis* (Borgatta) “of the adjustments and modifications” that the tax “imposes on individuals”, “to find the new relationships and the new behaviour that ensures them the same utility, after taking into account the intervention of the tax”.

As dynamics does not allow (as neither does the static view of the Walras models) “the treatment of problems relatively specific to this type”, in its development phase (1933) Borgatta admits that “we must be satisfied with rather generic approximations, obtained by simplifying the problem, often in an arbitrary way, even though we consider it a dynamic problem”.

“In order for it to be studied in terms of its repercussions, the financial event is *isolated* from other conditions of real equilibrium, bringing it to the initial situation when the tribute did not exist and applying the variations that have derived from it” (*Appunti [Notes], op. cit.*).

Borgatta states that “another *restriction* is generally adopted in these investigations: they study the consequences of the tax, considering it only in its aspect of *collection* from private economy; the modifications that the use of the collected tax simultaneously produces within it are not considered”. While he searches for justifications of this second restriction, he recognises that “in some cases such hypothesis cannot be admitted without invalidating the investigation” (pp. 327-29).

In turn, Barone admits that “if expressing the problem in all its generality is easy, it is not so easy to bring it to its conclusion”. He continues: “Nor would practical utility be commensurate to the enormous task”. “In fact, the general variations of equilibrium that are a consequence of a tax are intertwined – when long periods of time and remote effects are considered – with other more important variations, which are those due to elements of the equilibrium (pleasures, available capitals, state of technology, etc.), elements whose variability over time represents the dynamics of the market.”

It is such that Barone believes that extending the investigation of the economic effects of a tax over long periods of time has “limited practical value”, agreeing “that the investigation is limited to the verification of more or less immediate effects; that is to say, it is contained in those limits of time in which those elements of the equilibrium can in fact be reasonably be considered to be unchanged”.

After this limitation in *time*, Barone expresses a “restriction in the *extension* of the investigation”. “The tax has as the effect, in truth, of inducing variations not only on the *price* which it influences directly but – theoretically at least – also *all* the others. However, because of the viscosity and frictions of the market, as these variations of all other prices only take place after long periods of time during which the elements of the equilibrium change, it can be seen that it is opportune, for practical effects, to limit the investigation of the study of the variation of only the price on which the tax acts directly”. Even though limited in *time* and *extension*, the problem does not appear to him to be at all simple and easy (*Principii [Principles], op. cit.* pp. 271-73).

De Viti De Marco also explains why, after having expressed the general model of “shifting” (in studying the forces of friction that are encountered over time in the process of adjustment or adjustment of the supply to the demand), he proceeds to the analysis of many conceivable. So he admits the analytical study also of the behaviour of the “monopolist” as producer, and of the consumer, abandoning out of *necessity or convenience of study*, the model of the general equilibrium in whose spirit his concept rests, which is considered here as typical. In any case De Viti uses the arbitrariness exposed by Borgatta which consists of not taking into account the effects of State expenditure, an arbitrariness that recurs in many investigations, as debatable hypotheses of study, when this tries to simulate events.

I will not repeat myself to state that, even in the most modern investigations of economic dynamics intended to embrace the pendulum laws of the entire economic system (macro dynamics), the financial event is confused with other variations of the quantities considered: I have elsewhere indicated the reasons for my preference for micro dynamics as a schematic model of particular situations of equilibrium and the use of the “*all other things being equal*” clause, which is not compatible with the rigid vision of the general economic equilibrium.

In this way *simplified* analysis is justified, in a static and dynamic context to which the historicistic Marshall spirit is approximate, analysis that is frequently used for the effects of taxes in the context of specific situations of equilibriums, which highlight the fiscal event by isolating it for the purposes of analysis.

It is another way of approximating reality. The general model of the economic equilibrium embraces it by *extension*; that of specific or partial types of equilibrium approximates it in *depth*.

We presume that *not all* economic quantities change simultaneously; with the *all other things being equal* clause, few variations of quantity are introduced: those that each time seem to be “essential”, to use Pareto’s words, and that contribute most to the determination of the problem in the judgement of the theoretical formulator of the hypothesis. From the point of view of the closer examination of individual problems of the effects of imposition, the use of partial equilibriums

(exchange, consumption, production of *given* goods and, in general, *details* of the complex economic system) may appear to be more inventive and less sterile, taking into account marginal variations of individual fiscal institutions, considered from the qualitative (type of constraint) and quantitative aspect, isolating them from “mass” phenomena.

I explained to students in previous “courses” that the essence of this type of analysis, essentially atomistic, consists in identifying the details of the evolution of a specific given market, the behaviour of a given type of consumer, the hypothetical trend of conditions and productive cycles of individual products: all this in the Marshall spirit, according to whom “*each exact and secure treatment of a restricted question helps to deal with wider questions* (in which the restricted one is contained), *with greater precision than would be otherwise be possible*”.

Similarly, the causality, finality, deterministic and probabilistic principles *contribute* as logical routes, where and when it will be logically appropriate to shed light on the explanation of those events that we will examine in this part of the course.

It is not, however, necessary to say any more than has been said in the *Introduction*, to state that all these warnings and considerations that introduce the study of the effects of taxes have needed to make no reference to contrasting types of State. Constraints and frictions will affect, as we will see, types of dominating and hypothetical relationships on a market that may be differently regulated or directed.

Indeed:

a) in all types of State there will be hypothetically, in an atomistic context, subjects tending to conditions of individual hedonistic maximum, in other words aiming to return to this condition when the State financial activity overall considered will distance them from it.

State interference can, depending on the advocated and popular or promoted ideals of the governing class, also modify the psychological position of individuals, in the context of the vision of collective wellbeing, in the formulation of *correlated* individual hedonistic maximums. All this however belongs to the shaping of the consciousness of individuals, and influences the preferences of subjects or their choices.

The causal principle or the finalistic one sheds light on the study of the reactions of individuals faced with *perturbation* (which is not excluded in order to be favourable to the improvement of individual satisfaction towards a maximum of an absolute value higher than the previous one) such as it has been created in the individual equilibrium by the financial activity.

In this study we can clearly *disregard the types of State*, as it is not possible to demonstrate a necessary link with this condition which is external to the problem. On the other hand, the economic horizon in whose context, as a set of conditions that are the consequence of the hypothetical existence of a given type of State, the individual operates is of interest.

b) The same exclusion, and even more so, must logically be stated with regard to the vision of the study of the effects of taxes (and of public expenditure), as analysis of the variations of the disturbed economic equilibrium, on the entire market, by the financial activity. *Whatever* type of State, each collection of wealth and each distribution of it must modify the pre-existing quantitative relationships, as a rational necessity. This perturbation of previous relationships needs to be considered in function of the constraints that characterise the economic environment, with differences of degree and of species, disregarding even constitutional characteristics that are ideal or abstractly typical of the State and the relative choices of the hypothetical governing classes.

CHAPTER X

ANALYSIS OF THE EFFECTS OF FINANCIAL ACTIVITY

I.

HISTORICAL AND LOGICAL NEED TO GIVE PRIORITY TO THE CONDITION OF "PURE" OR "PERFECT" COMPETITION

The general vision of the effects of financial activity, such as is seen through the previous chapter, allows first of all the use of various terminological expressions mentioned therein (paragraph II), with the meaning and with the logical and methodological limitations that necessarily apply in this analysis. It also allows the avoidance of what, under the pretence of scientific progress, could become unilateral concepts in voluntaristic, causal or deterministic exclusive sense. For example, I would not agree with the idea of an updated presentation of economy as price theory (I refer to the praiseworthy work by Weintraub, *Price Theory*, New York, Pitman, 1949) in relation to different market situations. The work states that the actions of the enterprise are the focus of price theory, as determining behaviour, with the intention in this way of identifying "significant gaps in the old concepts, according to which prices were conceived as the result of impersonal and mechanistic market forces" (p. 97). This is a partial vision. Indeed, it is sufficient to follow the thought of the author – who had intended to make the point of the current state of economic knowledge – for a few pages to realise that all this was already known in the hypothesis of "pure" competition. That is to say, sellers and buyers are "individually impotent" in influencing market prices: that, in other words, "the price is a *given* for each participating individual, and it is a *variable* for the market" (p. 106).

The same preceding chapter coherently allows the link to Chapter XI of the *Introduction* with regard to the study of the effects of financial activity "in the hypotheses that reflect *conditions* in which the activity of the members of the community or bodies acting on their behalf takes place. These hypotheses can be very varied and can be identified in the most diverse and sometimes antithetical types of State or in economic orders of the most possible diverse human societies".

It is not possible in this edition of the "course" to give a complete analysis of the simplified series of conditions, constraints, etc., mentioned in that chapter of the *Introduction*, in the sense of the extension of the relationship with the main aspects of financial activity that take place in fiscal imposition and in public expenditure. However, reference will be made here to a good number of hypothetical conditions in the context of organisation of the market and characteristics of the given components of the economic environment in which fiscal constraints operate, and in function of these characteristics.

In the following analysis, therefore, we will take account in a systematic way in our arguments, with further, alternative and simultaneous intervention, depending on the specific case, of hypotheses relating to:

I) *conditions of the supply of goods and services:*

- a) pure or perfect competition,
- b) pure or total monopoly,
- c) partial monopoly,
- d) monopolistic competition,
- e) bilateral monopoly,
- f) other supply conditions (elasticity of the curve, hypothetical trend of rising or decreasing costs, over short or long periods of time, etc.);

II) *conditions of demand:*

- a) degrees of elasticity of curves (points, curvature, etc.),

- b) demand of complementary goods,
- c) succedaneous goods,
- d) “inferior” and “superior” goods;

III) *type of taxes:*

- a) fixed (as general expenses),
- b) fixed as a unit for produced quantities,
- c) proportional to price (*ad valorem*),
- d) proportional to income or to “profits”,
- e) specific or general;

IV) *exchange relationships:*

- a) focusing on finished goods (*output*), especially in progressive shifting;
- b) focusing on service producers (*input*), especially in regressive shifting;

This perspective presentation – which intends to be mainly illustrative – of the study hypotheses drawn to a great extent from the phenomonic complex of reality, does not intend to be exhaustive with respect to what will be examined in this edition of this course of lessons, in which *the simultaneous consideration of collection and distribution of revenues* are considered.

The first condition that we will take into consideration is the organisation of a particular *market*, which is presumed to be characterised by conditions of perfect competition (also called “pure” and “free” by others, in the meaning that will be clarified later).

(The reference to a “particular *market*” is intentional because it is not intended to exhaustively consider the complex of hypotheses that may characterise an economic system, such as has historically existed or could be imagined in abstract).

The reasons why the analysis starts with the condition of perfect competition are of a different order:

- a) historical, in the Cartesian sense of the assumption of hypotheses from facts;
 - b) rational, as competition is one of the components of the eclectic real phenomenon.
- a) It has been stated in the *Introduction* that the hypotheses assumed may or may not be drawn from a past, present or possibly future reality.

Those who believe that it is the duty or task of the academic to provide an explanation of the economic system and suggest taking “pure” competition (which has no monopoly element, because it is *pure*) appear to be concerned with taking into account news chronicles that reflect the most frequent characteristics of the economic system. I am referring for example to Chamberlin who around 20 years ago (with *The Theory of monopolistic competition*, Cambridge, Mass. 1933), in attempting to illustrate how competition is in fact rarely free from elements of monopoly, started from the “starting point” of “pure” competition by studying the genesis of price in this hypothesis and in that of total monopoly, to then pass to examine closely, in fact, monopolistic competition as the most frequent in practice.

About 20 years later, in a series of conferences on the same theme held in European universities (the text was published in *Economica*, Nov. 1951), among other things he wanted to explain how he would now approach this matter, concluding that he would replace the hypothesis of “pure” competition with that of monopolistic competition as a base on which to analyse the entire economic system.

The link between theory and facts must follow historical developments to maintain an explanatory order. And while “pure” or perfect competition has become a particular case in itself, it is necessary to give priority to this hypothesis that reflects a situation that once was dominant in reality.

Indeed, we have read in the work of Amoroso, illustrious theoretician (*Principii di economia corporativa [Principles of corporate economy]*, Zanichelli, 1938) that “competition, which a century ago, at the time of Ricardo, could have appeared to be the configuration towards which the economic universe was aiming, is becoming today more and more an exception”. Similarly Samuelson, to quote a young author who has recently become well known, agrees by stating that “a great part of modern

life is conducted in the context of monopolistic competition” (in *Economics, op. cit.*); Jane Aubert, in the popular monography on “*La courbe de l’offre*” [*The supply curve*] (Press. Univ. res. de France, 1949, p. 30) also concludes with some general observations stating that the monopoly element (not so much monopoly itself) “represent[s] the rule and competition the exception”. I will limit myself here to these few significant quotes.

However, the same Amoroso finds that the case of the “perfect” competition or of broken-down production or not likely to influence market price, corresponds *by and large* to “that which still today dominates in the agricultural or craft field”, after recalling that these conditions were the reality in the period in which large industries arose and became established. The same Samuelson (p. 491 of *Economics, op. cit.*) finds a correspondence between the hypothesis of “perfect” competition and conditions in a “few sectors” of agriculture.

Furthermore, in a commissioned volume of *Economic Analysis* (Harper & Bros, New York, 1948), Boulding believes “perfect” competition to operate in the share market and in the market of some goods (he refers to the example of the cotton market, on p. 51).

These few references, among many others, are useful in attesting to a correspondence between the visions of theoreticians in the field of hypotheses suitable to interpreting the idealised or simplified reality and historical phenomena that both in the past (priority of the case of agriculture) and in the present are thought to be able to be explained, as the current events, with the hypotheses of “pure” and “perfect” competition.

Of course a rich series of quotes could also be supplied to support the idea that pure or total monopoly is the hypothesis to which “rare” real cases correspond, especially in the current market economy. Chamberlin (*Economics, op. cit.*) – as substitute or surrogate goods of the object of a possible “pure” or total monopoly cannot be excluded, and therefore there is no certainty of being able to entirely control the market – states that pure monopoly requires the possibility of controlling *all* economic goods. This appears to him to be “only conceivable in the case of State socialism”.

From a historicistic point of view, therefore, as events in the order first of all considered by economists (agriculture, crafts, first phase of large industry, trading in titles of moveable goods, prime materials, etc.) *by and large* corresponded, or correspond, and implemented the simplifications of the real case of yesterday or today, it is possible to start the treatise with the hypothetical introduction of the condition of “pure” or perfect competition.

b) However, it is interesting to also consider the rational aspect of the problem. I am still referring to Chamberlin who, in the work just published proposes to revolutionise his presentation by giving priority to monopolistic competition and no longer to perfect competition, followed by pure monopoly and by intermediate hypothetical cases.

Indeed, whether he explains *monopolistic competition* as a “fusion”, “amalgam”, combination of forces and corresponding theories of “pure” competition and “pure” monopoly, or whether he compares with it imperfect competition as a “dichotomy” of theories, still separate and not fused together, of competition and monopoly, what it is necessary to admit from a rational point of view is the logical *priority* of the existence of elementary forces or hypothetical *elements*. Indeed, before profiling the hypothesis of monopolistic competition as *composed* of or as a combination or mix of conditions or hypotheses, it is necessary to recognise the prime elements from which complex situations derive, elements that are analogically qualified by referring to chemistry. This is also the science that imposes the sequence: 1) elements; 2) combinations, from the historical and logical point of view.

Other authors, like Chamberlin, refer directly to the hypothesis of monopolistic and imperfect competition when starting their presentation, but they inevitably focus on competition and monopoly. Robinson (in *The economics of imperfect competition*, MacMillan, 1934), after reporting Sraffa’s views (who suggested starting the theory of value by starting from the concept of monopolistic enterprise), admitted the need to borrow “marginal techniques from the old manuals’ chapters on competition, adapted to new objectives” (p. 6).

This need was expressed from another point of view by Demaria (in *Principii di economia corporativa [General principles of economic logic]*), after consideration of perfect competition as a limit case, to which economists make reference for two reasons. I recall one which is appropriate to

the vision considered in these lessons: “because this theoretical model is eminently suitable in the formulation of laws of real phenomena as, once the configuration of the ideal equilibrium is known, events from economic reality can be interpreted as more or less close deviations of the perfect model” (p. 255). (In fact Chamberlin dealt with “deviations” from the equilibrium of “pure” competition in 1933, before the methodologically “revolutionary” approach adopted in 1951 and contradicting himself, as we have seen).

To conclude these warnings, which are not an end in themselves, the historical and logical requirement of the start of the study of the effects of fiscal imposition starting from the condition of “pure” or “perfect” competition seems sufficiently justified by what I have already said, in explaining to the reader the *mainly rational* reasons for the distribution of the matter of these lessons.

I have used, to abide by current terminology, the expression of “pure” and “perfect” competition, which it was customary to define as “free” competition, especially in the past.

α) Having said this, I refer first of all to the meaning of “free” competition, which links to the typical indication of the modes and degrees of constraining intervention by the State in the economic field, as a vision quoted in Chapter XI of the *Introduction* of this course.

According to some, *free* competition expresses the elimination of privileges and monopolies allowed and defended by the State. Freedom is intended as equality of principle of positions in the economic battle.

Others develop the concept in the sense that free competition means the absence of constraining interventions by the State, of other external entities or compelling forces: therefore a condition of *laissez-faire*, *laissez-passer*, which they identify as belonging to an historic phase of the recent past (before the war).

β) However, we are interested in the distinctive criteria with which we started this chapter.

In this field there is a differentiation between *pure* competition as the condition of market economy, with offers of homogeneous products, which does not contain any element of monopoly: the market curve is perfectly elastic and parallel to the abscissa axis for every enterprise. There are several buyers and sellers for the same identical product.

However, I am referring to the qualification of competition as *perfect*, of which three characteristics have been indicated: broken-down production, and then no offerer is able to influence the market price with his own goods; homogeneity of the goods offered; perfect mobility of productive factors.

We will then make reference to a concept of perfect competition, qualifying it in the sense that the characteristics indicated (and others to which I refer, for example, the quoted Demaria) work in such a way as to “reach the state of *maximums satisfaction*” of the community of participants, in terms of level of prices and quantities exchanged.

This observation also means that if any of the characteristics indicated, or others that appear in economy books used for teaching these problems of economy, are not present, it will be necessary for the remaining ones to operate in such a way as to achieve this maximum advantage or satisfaction of the community of participants¹⁸⁷.

γ) “Perfect” competition is further qualified as “full” by the English and as *ideal*, with the meaning that Amoroso ascribes to the term, to indicate the effect of the indefinite reproducibility of more favourable conditions of supply, so that the numerous competing enterprises produce at the same (minimum) cost with the same price, marginal cost and average unit cost.

¹⁸⁷ Insisting on specifications in the context of the characteristics of perfect competition has a purpose. We will see this with regard to the hypothesis of decreasing costs, which is normally considered to be incompatible with that of perfect competition. For now I will recall that this, according to Demaria, who is up-to-date with scientific developments, can be valid when we hypothesise (in spite of the characteristic indicated above of “breakdown” of production) a single seller-producer who sells at cost price. Monopoly indicates a single offerer. In the limit case that always implies potential competition, it is possible to envisage this depending on the mode of operation, finalistically or voluntaristically considered, of the single offerer in the context of policy of prices and quantities offered.

This hypothesis is supported by further visions, which are not taken into consideration by Demaria judging by the bibliography that he indicates, for this chapter in his treatise.

We will further discuss this condition called final and long-term equilibrium.

For now I will start to consider the intervention of some simultaneous hypotheses regarding:

- a) the supply in the context of perfect competition, increasing and decreasing costs due to:
 - I) all enterprises, with market equilibrium;
 - II) an enterprise coexisting with others in a relevant or large number;
- b) the more or less elastic demand curve, influenced or otherwise, in terms of its level, by public expenditure;
- c) the type of tax (by unit of produced goods, proportional to the price of goods, etc.);
- d) brief periods of time.

II.

TRANSFER IN CONDITIONS OF PERFECT COMPETITION, ELASTIC DEMAND AND INCREASING COSTS.

It is necessary to understand clearly the difference between the demand curve for the overall market or *industry* which feeds that market with its total supply, and the demand curve for the *individual company*. Only for the latter, according to one of the conditions or characteristics of perfect competition, does demand become parallel to the x-axis, in the traditional graphical representation.

(This difference has not always been perceived in theoretical financial works and the error of the lack of differentiation has not even been corrected in those in which we insist on denying compatibility, even in the limit case, of the hypothesis of decreasing costs with that of perfect competition.)

Indeed, with regard to demand, each individual buyer accepts the price as stated and adapts his own budget plan to it. But the overall *set* of buyers (who belong, as we have seen with regard to public price, to different income groups with different levels of purchasing power) has an influence on the inclination of the demand curve.



Figura 25.

Similarly, the individual company offering goods to the market does not influence the price *directly*, but the set of companies offering the same goods makes the price, as we have seen, a variable of the market depending on the quantity on supply.

Having established this, we can trace a global supply curve and one for the demand for the entire market in conditions of perfect competition, leaving aside the exceptional case of ideal perfect competition which would lead to an supply curve parallel to the x-axis (constant costs), tangential to the curve of average costs at its minimum point and excluding any non-standard earnings, which

would be necessary to avoid the removal of investment and activity from that market. The difference between price and unit average cost in the condition of *non-ideal or complete perfect competition* has the nature of income.

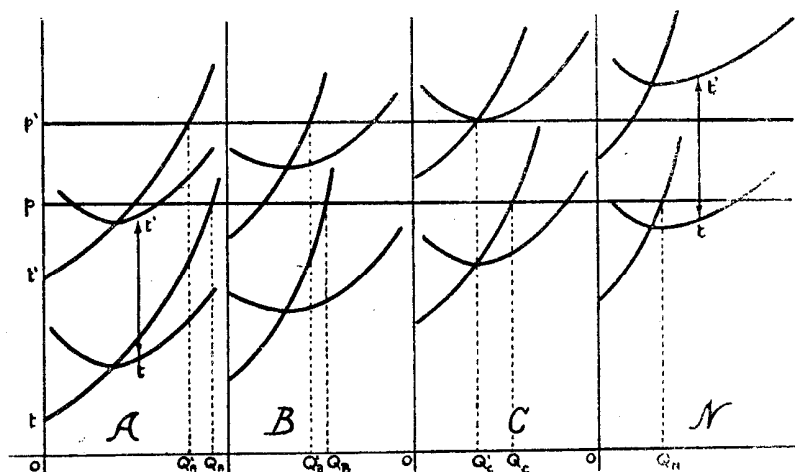
This can be seen in the discontinuous graphical representation for individual companies bringing specific quantities of goods to the market. However, in the context of the single curve for the collective supply the quantity contributed by each of the numerous coexisting companies must be considered infinitesimal (corresponding to a single point on the x-axis in the figure), so that the supply can in fact be represented as a continuous curve.



Figura 26.

In this case, while the same scale can be used with regard to the y-axis, which relates to costs and prices, in this case a conventionally smaller scale may be adopted for the quantity axis (x) which, as we have already mentioned, represents the sum of the offers from individual companies coexisting in a perfect competition system.

The formation of a point of equilibrium between an *individual* and a single company can be observed in relation to the presumed taxation context (see Fig. 25 where the demand curve is parallel to the x-axis, as has been stated above).

In the short term and in conditions of “incomplete” or not “ideal” perfect competition, the equilibrium points of companies *A, B, C, ...N* are identified, following a procedure quite common in economy books, in those points where marginal costs are equal to market price.

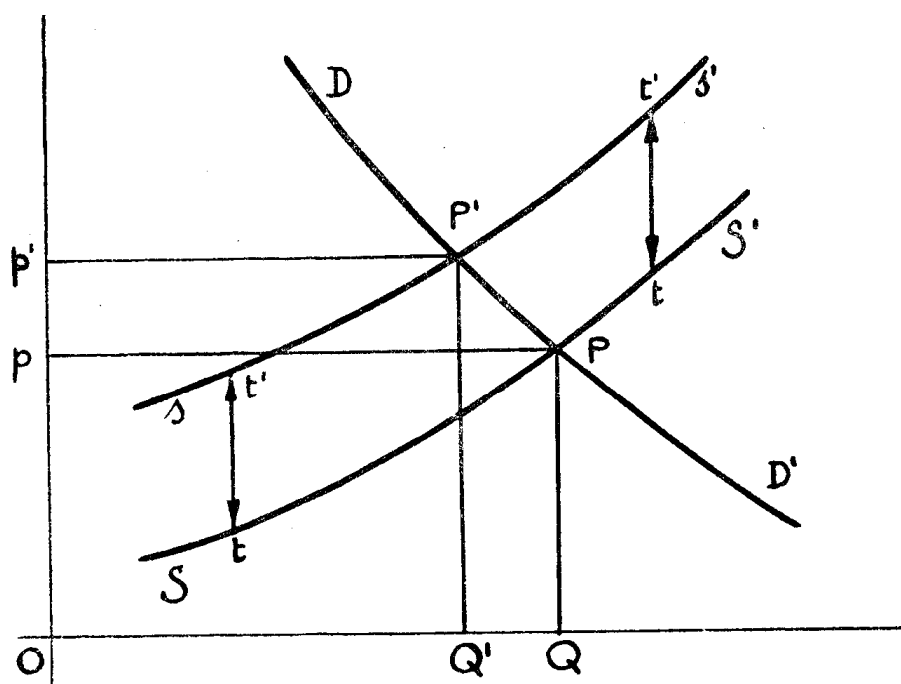
The price for the *industry* whose supply is made up of contributions from companies in perfect competition is determined by the meeting of the collective curves of demand *DD'* and of offer *SS'* (Fig. 26).

If we hypothesise the introduction of a tax *tt'*, for example a fixed tax for a quantity of produced units, which has the effect of raising

uniformly all (average and marginal) cost curves, equilibrium will be identified in the meeting point between the demand curve and the consequently transposed supply curve *ss'*, that is to say, in *P'*. The quantity offered will decrease from *OQ* to *OQ'*, due to the failure to supply of companies which have become extra-marginal as a result of the tax (such as *N*). Company *C* becomes marginal. Given the elasticity of the demand curve in the market, the price increases from *PQ* to *P'Q'*, that is to say, *less than the value of the tax, as $pp' < tt'$* .



Figura 27.

This condition will affect the profits of the *individual non-marginal company*.

As the demand curve is, by definition, a parallel of the x-axis, its level will increase in a manner related to the increase of the price on the *demand curve of the industry* on the market.

If two parallel lines of equal ordinates are drawn, relating respectively to points P and P' , identified as equilibrium points *for the industry* before and after the tax, a new intersection point is identified between the demand or price line and marginal cost.

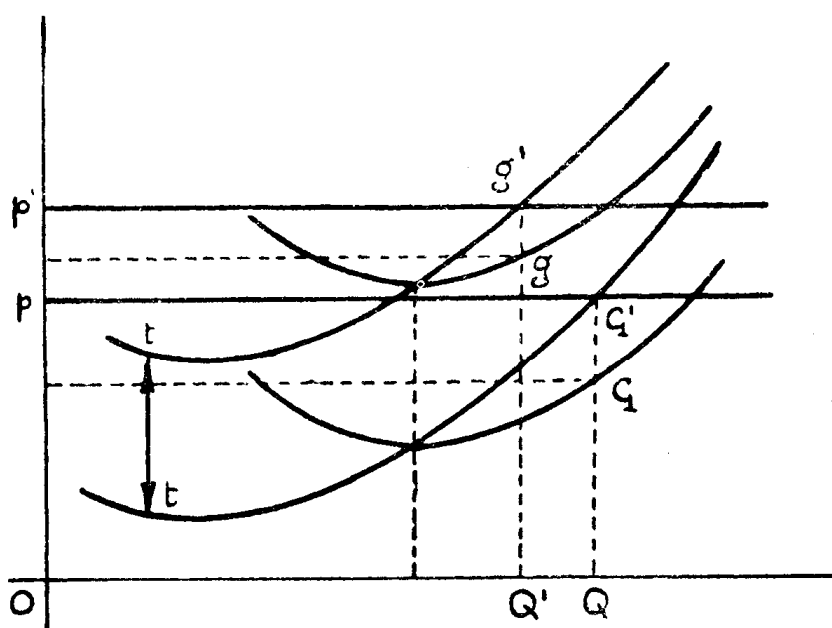
The difference between price and average cost indicates the profit per unit (gg') which, multiplied by the quantity (OQ'), indicates the total profit for the individual company in the market.

After the tax, which has raised cost lines by the amount measured on the y-axis, tt' greater than pp' , both unit profit and overall profit decrease. This indicates that the burden of the tax will be distributed, having an impact in part on buyers, in part on manufacturers-sellers: in fact $OQ \times GG'$ is greater than $OQ' \times gg'$.

The extent of the tax impact varies depending on the elasticity of demand. This is also true when this concept is applied to the overall industry.

The argument needs to change if we consider the hypothesis of *ad valorem* taxation, *measured proportionally to the cost of the goods*, the type of taxation on consumption or sales which is considered to be systematically transferred to consumers.

The theory considers this case as *equivalent to an increase in costs*.

In the graph (Fig. 28), which considers the comparison of the market demand curve DD' with that of the industry (average) costs CC' (consistently with the hypothesis of free competition), it becomes apparent how the impact of an *ad valorem* tax pP on price PQ leads to variations in price and quantity greater than those due to the introduction of a *specific* tax of value equivalent to pP . In fact the cost curve, raised for example by cc' (obviously not in parallel to itself, given the decrease of prices to which the tax is commensurate), determines a new equilibrium point P' such as $P'Q' > p'q'$ and $OQ' > OQ$, as point p' is the equilibrium point compatible with the specific tax, that is fixed for unit of product, corresponding to the cost curve ss' , parallel to CC . It is also the case that tax $P'V > pP$.

To account for the specific variations shown in the graph (Fig. 28), which compares the two tax collection hypotheses, it is assumed that in introducing the two types of taxation the State applies a proportional approach to the pre-existing market unit price (PQ), with an equivalent additional impact on the price itself.



Figura 28.

Generally speaking, however, the actual phenomenology does not support this hypothesis, which is convenient for the purpose of study and for comparing the effect of various types of taxation. In other words, their alternative adoption can be independent from the equalisation of their effect on the equilibrium price (PQ), and such independence of choice in terms of alternative taxation need not be in conflict with the graphically illustrated theoretical uniformity. Furthermore, the previously mentioned graphical representation excludes the clause, resulting from other theorematic visions, expressed in the term “equivalent income for the State”. The reader can easily grasp the application of this clause in the interpretation and its graphic expression.

Clearly the effects studied also depend on the elasticity of the supply curves.

It has already been seen that these same effects are influenced by the elasticity of demand for the overall *industry* (as elasticity is infinite in the case of demand for the company which coexists with many others in a situation of perfect competition). It is, however, known that the extent of demand, which in this specific case represents the level of both price and profit or marginal earnings¹⁸⁸, depends precisely, *in the case of a single company*, on the trend of the demand curve for the industry which is served by the supply of all these companies.

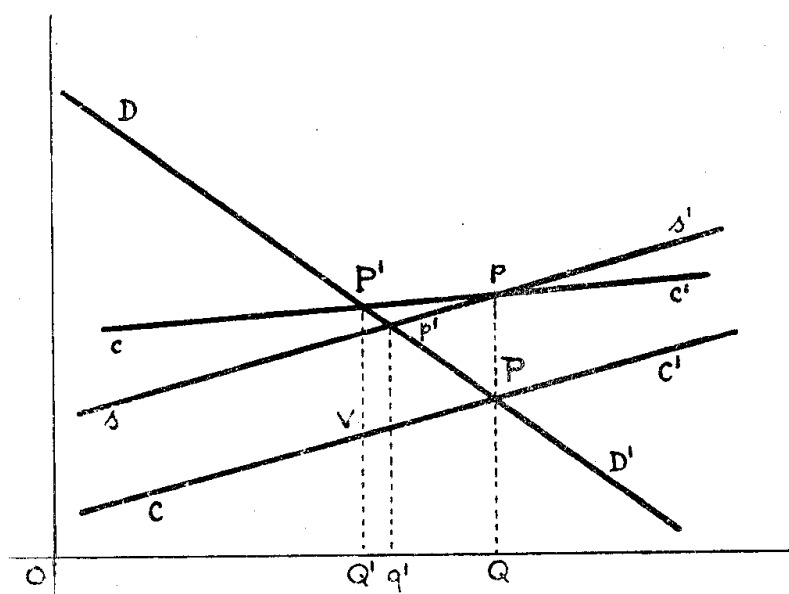
¹⁸⁸ Attention is drawn to the concept of profit or marginal earning to which reference will also be made later on, to differentiate it from price or average earning, even though it should be assumed that this is a concept known to readers familiar with political economy.

Marginal profit, as a variation of total profit deriving from the sale of a product unit, is the result of two variations of quantity: 1) the profit deriving from the sale of an additional unit, for the new price; 2) the loss of profit due to the fact that all units that could have been sold at a higher price now have to be sold at a new price (lower). Total profit increases if the first value is greater than the second, so that the marginal profit is positive if total profit increases.

In symbols, if mr is marginal profit, P_2x_2 is the product of the new price $p_2 = p_1 + dp$ (dp_1 being the variation) and increased saleable quantity ($x_2 = x_1 + dx_1$) at such a price; p_1x_1 is the product of the quantity that can be sold before and the initial price, it can be said that

$$mr = p_2x_2 - p_1x_1 \quad [I]$$

In the specific case here, that of (ideal) perfect competition, the demand line for the company is equal to the parallel of the x-axis; that is, it does not admit variations of price, which remains constant for each unit of x and for the total quantity offered; so that $dp = 0$, and [I] is reduced generally to $dx = I$, so that

$$mr = p \quad [II]$$

Both the extent of taxation, with regard to the price, and the decrease in quantity due to this taxation, can make the tax in these two relationships relatively small or large.

In the first case, with reference to elasticity of demand (or of the supply), this must be viewed as point elasticity, that is, around the equilibrium point. In the second case it must be considered as elasticity of the arch of the demand curve, along which the price variable moves, as a function of the modifications of the supply curve, influenced by the extent and type of the hypothesised tax on goods.

With general reference to the diagram (in these demonstrations in which students' preferences are followed for the graphical rather than the analytical representation), it is easy to infer modifications to prices, costs, quantities, and proportion of incidence on the profits of the (non-marginal) producer and on consumers, when working within the hypothesis of rigid demand and nil elasticity, which can be described as a parallel of the ordinates (prices) axis.

The case of the perfectly elastic demand curve is not considered, as it has been seen that this *cannot* be applied to the industry but only to the company. Similar considerations apply in the case of elasticity of the supply curve.

III.

SHIFTING AND DECREASING COSTS

Leaving aside the rather rare case of the supply at constant costs, whose logical legitimacy is not disputed, I move on to consider the case of decreasing costs that, even according to some respected academics, should not figure among the hypothetical propositions in these demonstrations of the possible effects of taxes. I do so for theoretical purposes more than because of the importance of the corresponding real situations.

In the previous edition of this course, in particular referring to Fasiani, who believed like many other economists the conditions of decreasing costs and perfect competition to be incompatible, I mentioned the position of academics such as Amoroso, Barone, Sraffa. The latter, in particular, had reviewed the undisputed positions of Marshall, who introduced the above hypothesis while considering average costs. (Robertson, Shove, Pigou, the same Sraffa, Kaldor and others debated this both in works published in the "Nuova Collana di Economisti" [New economists series] and in works listed in the bibliography used by Weintraub, which provides an update with regard to this).

Geometrically the relationship between the demand (or average profit) curve or line and the marginal profit curve or line is identified by deriving the second from the first:



Figura 29.

To simplify, assuming that the demand and marginal profit are straight lines, the inclination of the demand curve is double that of the marginal profit curve; the area $ODsrq$, comprised between the marginal profit line and the axes, is equal to the area of rectangle $Ovpq$, derived from the product of the price and the quantity offered; line Dr , the marginal profit line, has the same values of x , halfway to those of the demand curve DD' . The section $rq < pq$ identifies the marginal profit relative to the quantity Oq offered at prize pq .

In this course I could follow Dalton's system (*Public finance, op.cit.*, p. 78 of the 1949 edition) which continues to suggest the hypothesis of the curve of decreasing supply, in the context of competition, in the study of the effects of taxes, for example on the units of goods produced, observing that: "Much has recently been written with regard to the conditions, if any, in which this simple concept is legitimate. I cannot explore these byways here, no matter how interesting they might be."

However, I want to add the hypothetical case of decreasing costs for the following reasons: 1) because there is still confusion between demand and supply by the *enterprise*, and demand and supply by the *industry*, in many essays and also in the new edition of Fasiani's *Principii [Principles]*, in which Fasiani continues to believe the hypothetical coexistence of decreasing costs and competition not to have any serious grounds; 2) because the theory, which Demaria for example presents and has kept in mind and which I have recalled on purpose on the first paragraph of this chapter, contemplates the condition of perfect competition of a single seller-producer who sells at cost prices. This gives value to a case hypothesised by Barone and Pigou, as I recalled in 1944, whose logical legitimacy I believe is confirmed in the quoted works of Robinson and Aubert, that is to say by the most recent marginalistic literature. 3) Finally, as I have had the opportunity to mention this point of view, I return to the case that legitimises the coherent coexistence of decreasing costs and perfect competition, having obtained the oral consensus of the same Sraffa who, in a timely essay raised the main doubt on the contradictoriness of the assumptions.

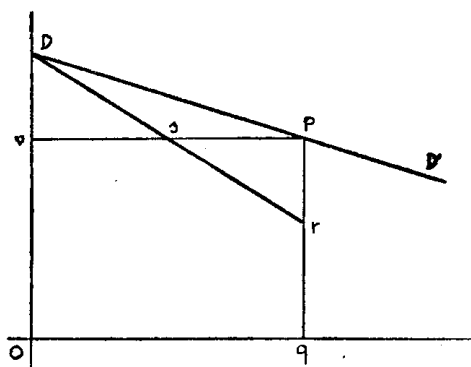
It would be useful also to refer to what has been said before with regard to the supply curve that, for the *industry*, is derived by adding up the quantities of goods offered by each enterprise on the x-axis, considering for each one the intersection point between the ascending branch of the curve of marginal costs with the price line: from this derives the collective increasing supply curve *SS'*, which we have considered as the normal hypothesis and, so to speak, the natural one in conditions of the perfect competition market.

A) However, in *the short term* (in the hypothetical context we are considering) I find first of all confirmation in one of the most detailed and in-depth analyses, that of Aubert's supply curve, introduced to academics by a representative economist of our times, the well remembered Chamberlin, who illustrated the hypothesis of imperfect conditions, as we have said. For this condition the hypothesis of decreasing costs would be coherently connatural (as it would be for total monopoly). However, in Aubert's monograph the theoretical possibility of decreasing costs is suggested in conditions of perfect competition, if costs are proportional to the quantity produced. If average costs are decreasing (in a note on p. 107), the marginal costs curve is consistently lower than the average costs curve.

The author refers to a real example that can be found in the well known work by Robinson, which I would like to introduce¹⁸⁹, and which confirms the inclination of average costs in a

¹⁸⁹ In the short term, decreasing costs are admitted if variable ones are directly proportional or if the marginal cost remains constant while the average cost decreases. These results are made up of two elements, one whose quantity varies directly with production and one which is constant. It is usual to use the example of the production of medals, whose special cost is 1, expressed in any currency, obtained from a coin of cost 100 and with the employment of two men (no more no less). The marginal cost will be 1 = constant; the total cost for a number of coins between 1 and 100 will go up from 101 to 200. The average cost will decrease according to the ratio 101, 51, 34 $\frac{1}{3}$, 26.....2. That is to say according to the trend

continuously decreasing trend, and higher than the marginal cost curve, which *does not determine* the quantity offered as it does not intersect the price curve.

B) It could be said that it was short-sighted of Aubert not to perceive the vision of the hypothesis that *a single enterprise* (Barone, Pigou) could provide the supply of an industry or, as Pigou expressed it in the Italian shifting (Appendix III of *Economia del benessere [Welfare economy]*, at p. 700 of the 1947 Utet edition), the hypothesis of “*industries with only one enterprise*”.

Robinson, who, however, admits that the marginal cost will always be lower than average costs when average costs continue to decrease without reaching an absolute minimum, fears that the expansion of the “firm” (or the absorption of other coexisting ones) leads to the reduction of the number of enterprises, bringing to an end the conditions of perfect competition.

In a *deterministic* context, as mechanical inevitability of the behaviour of the single enterprise in the sense of being nearly or completely monopolistic, it is possible to admit this incompatibility between decreasing costs and perfect competition. However we have seen that economists, implicitly introducing the element that I have before qualified as *finalistic* or *voluntaristic*, have conceived the case, as Demaria (*op. cit.*) reported by reasoning, of a single seller-producer in a regime of perfect competition in the sense that the single offerer intends to preserve the characteristic of this ideal market condition represented by a policy of prices that preserves the state of traders’ “maximum satisfaction”, obtainable with the breakdown of the supply, without crossing the line towards monopolistic attitudes.

The characteristic of perfect competition, that is to say the breakdown of the supply, represents a situation that suggests that the single enterprise *cannot* influence the market price. However, the supply on the part of a single “enterprise” or a single seller-producer, as it is *not* an insignificant but a directly determining quantity, can achieve the same effect for the market because they, *even though they can, do not* adopt prices different from the one in which there is equality with the average cost, along the curve of decreasing costs.

The behaviour of the single enterprise, according to a vision that characterises modern global economic literature, particularly in the case of monopoly (as was seen with regard to the progressive imposition and how we will see later), even in a competitive context, can be directed by subjective motives and preferences, relating to the domain of spiritual *satisfactions* in the wider sense, beyond pecuniary motives. Furthermore, as was said in order explain the apparent literal paradox, this enterprise behaviour (which bears market prices even though it represents the industry and could therefore control them), can be dictated by fear or by the expectation or the risk of potential competition of other enterprises entering the market.



Figura 30.

of an equilateral hyperbole cc' , asymptotic to the marginal cost line, which in the specific case is a line parallel to the x-axis, with ordinate I.

Quoting Barone and Pigou, it can be seen in the text that the condition of average decreasing cost, generally speaking higher than the marginal cost, is generalised beyond the frequently recalled limit case of this note.

All this legitimises the introduction of a price or demand curve that is sloping and not parallel to the x-axis (given that this applies to the single enterprise that *coexists* with others and not for the industry “with a single enterprise” that Pigou refers to), *as if* all the conditions of perfect competition were in place. (Fasiani did not see this, for example, in the already expanded edition of *Principii [Principles]* of the science of finance in 1951.)

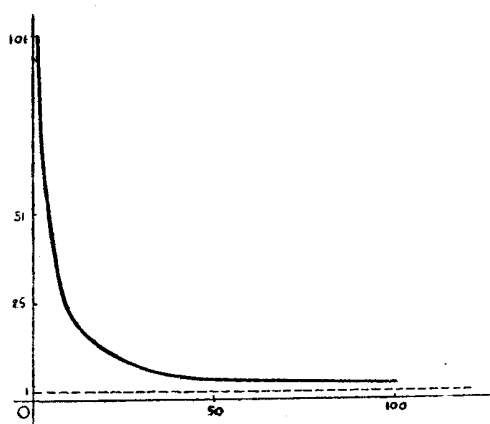
Coherently with the vision that inspires the *Introduction*, I consider the case, even though in practice it might represent a limit case or a non frequent or more probable case in the future, with the evolution of the “social consciousness of producers”; I move to the demonstration on the basis of the hypothesis, legitimate after my warning, by letting the fiscal *event*, in the meantime configured as collection of a tax on the quantity offered or produced, intervene.

Let DD' be the demand curve, inclined with respect to the axes, considering the hypothesis of an “industry with a single enterprise” and yet with genesis of prices of perfect competition, borne by the seller-producer, who infers them from the demand of the market which he does not influence and which he does not exploit with monopolistic intentions.

Let CC' be the curve of the average cost, continuously decreasing. Let C_m represent the marginal cost curve. Let's determine the corresponding quantity sold OQ at price PQ in the point of intersection between the demand curve with that of the average cost (which represents the supply curve for the industry). All quantities are sold at the same price, as the condition of perfect competition demands, and there is no interest in selling a greater quantity of OQ , for example OQ' , in spite of the fact that additional quantities of product cost less than $PQ = OV$, because that would lead to a loss as $P'Q' < MQ'$. It is *as if* the firm or enterprise is one among others coexisting firms or enterprises in a regime of perfect competition and the price equals the minimum average cost of production, with the price line tangential to this minimum point.

Let's introduce a tax on produced units, which has the effect of raising the curves of average and marginal costs. The line cc' will intersect the demand curve (which we assume to be unchanged in the market) at point P'' , determining a supply lower than OQ , and exactly the supply OQ'' . As $TV > TZ$, the difference between $P''Q''$ e PQ is clearly



Figura 31.

greater than the tax Cc , measured from the distance between the pairs of cost curves raised by the tribute.

The difference in prices indicates the incidence on the market. It depends, as we have seen in terms of the case of increasing costs: *a*) on the elasticity of the demand curve (in terms of points and of the arches of the curve); *b*) on the elasticity of the cost curve; *c*) on the amount of the tribute.

The argument can be repeated on the basis of the hypothesis of a tax according to value.

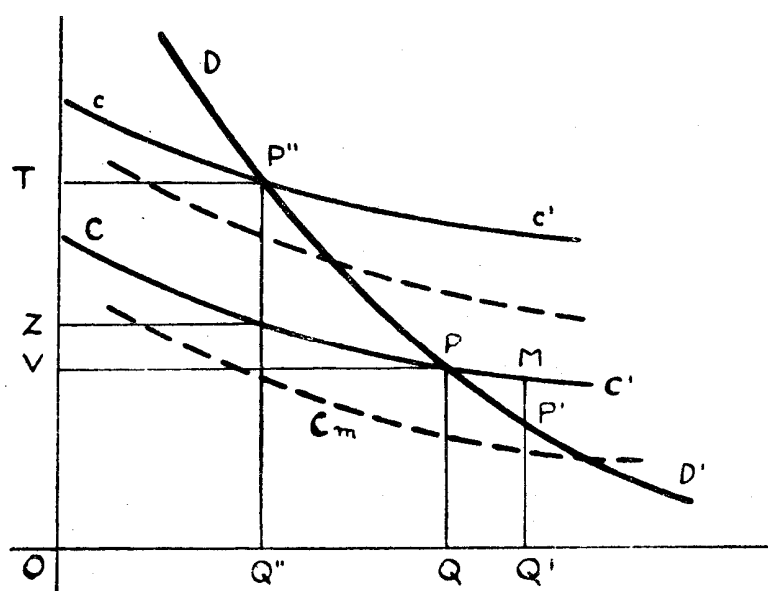
C) A regime of decreasing costs, in the hypothesis of perfect competition, can be conceived in the long term if we introduce the element of the influence of Marshall-type *external economies*. This is a concept that some find undefined but which plays a part in recent pure economy treatises for dealing with the explanation of increasing productivity. This is due, precisely, not only to the use of combinations internal to the enterprise, but also to the external environment for which examples have been given previously in these lessons. In the 1944 edition I recalled an intuition by Edgeworth with regard to the theme of compatibility over time of perfect competition with the hypothesis of decreasing costs. I wrote then that he intended to refer not to the supply curves in the traditional sense, which are *always increasing* for *short periods of time* (with the proviso, however, of the warning of the case illustrated earlier) and which are called “*primary*”, but to an supply curve of the industry in an regime of competition, considered over *long periods*, and “*derived*” from primary ones.

Before tracing such a curve, which the same author defined as having “many branches”, I recall a similarity that can clarify the concept for the student. I refer to *Pure theory of taxation*¹⁹⁰ where it states: “Some of us have climbed the slope of a mountain right to the point where our desire to go further was exactly balanced by the difficulty of the ascent. This is the position of the economic man on a curve of *primary supply in the short term, going up* (rising).

Let’s presume that, while a group of climbers go up a steep slope, the ridge in front of them suddenly gives way so that they now find themselves dragged down by a sort of avalanche and they find themselves on a new slope. Again they push forward and upwards and again, before being able to reach the top, they find themselves dragged down to a new level, and so on until they are forced to stop at a relatively stable point of the steep slope. The route they have covered in space, even though in fact it is broken, in some way might appear to be a curve. Such is, perhaps, the nature of an industry subject to competition obeying the law of increasing productivity; in the short term it follows an upward curve and in the long term it will follow a decreasing supply curve.

“Let’s presume that our group, after a stop on a short slope, feels motivated by a new stimulus; it could overcome a new ridge and go down for an extent of path that is out of proportion with the stimulating cause. On the other hand, the imposition



Figura 32.

of a new burden could have prevented this onward march. Such it is that, in an industrial regime of the type considered, a premium can reduce a price and a *tax increase it, in a disproportional manner*”.

As Edgeworth, in giving the idea of the curve “with many branches”, in other words, of the “derived” curve (long periods) from “primary” curves (for the short term), made reference to the

¹⁹⁰ *Op. cit.*, pp. 309-310.

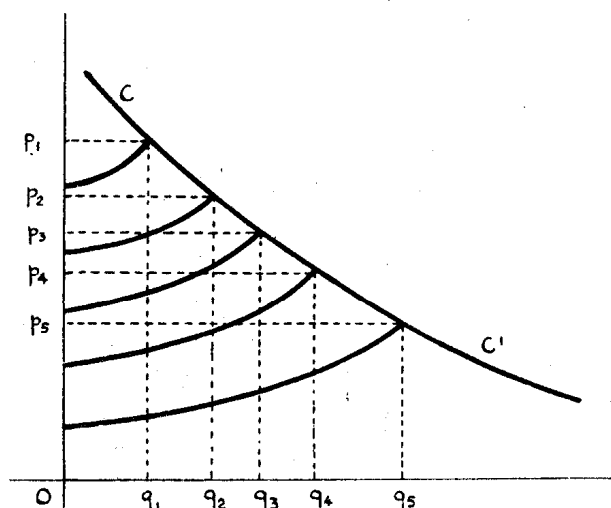
curve of successive costs, so called by Cunynghame, I derive from the latter's essay ("Economic Journal, vol. II) the type of curve that had been forecast, completing and presenting it with the convexity towards the x-axis for uniformity of representation.

However, I will warn that in representing the curve to which a group of successive curves is "attached" in the diagram, Cunynghame intended to suggest a state of fact existing *at a given time* and not a set of subsequent phenomena.

If the "primary" or short term curves – Edgeworth concludes – are decreasing, presumably the case in question is one of monopoly.

In the preceding geometrical demonstration, a collective supply curve with decreasing costs can be recognised if the line *CC'* is taken into account. This line is not broken because it is meant to represent *continuity* in the case in which there are very few variations which appear in the graph in a discontinuous manner, but numerous influences of "external economies" in a large market dominated by perfect competition.

IV.

SHIFTING IN CONDITIONS OF PURE AND TOTAL MONOPOLY

A) Before moving to consider the case believed to be the most frequent in a market economy, represented by monopolistic or imperfect competition (concepts that Chamberlin, who introduced the first, tends to separate in the sense that will be indicated later), that is to say, the case in which competition and monopoly are fused and co-exists, we will consider the hypothetical condition of the limit case, rarely found in reality, of the *pure monopoly*.

As we know, this would be a single enterprise or group of linked enterprises, motivated by the objective of achieving the maximum possible earnings allowed by: *a)* the possibility of bringing to the market a product completely different from that of any other enterprise; *b)* the exclusion from or impossibility of access to the market for other enterprises. Furthermore, to a greater or lesser extent, products can be replaced so potential competition is such as to exclude the case of pure monopoly. We can discuss in terms of *degrees* of monopoly, presuming that the maximum degree allowed by the possibility of substitute or surrogate goods applies to the specific market in question.

To examine the variations in price possibly due to the influence of the fiscal event, we start by characterising the equilibrium price in a regime of a monopoly that, to differentiate it from the "pure" one believed to be unrealistic in a market economy, we will define as *total*.

I) While up to now the equilibrium price (perfect competition) has been such as to allow us to match demand and supply in the market, we normally presume that the monopoly price does not have this characteristic, which the most cautious theoreticians consider probable (as they do not exclude it).

a) As a result of the manipulation of the price, along the infinite options represented by the demand curve, which is inclined over the x-axis as a market or industry curve, as some call it,

b) or as a consequence of the manipulation of quantities,

there is, by definition, a *supply quantity* that is normally presumed to be *lower* than that which could be found in conditions of perfect competition.

II) Furthermore, in contrast: *a)* The possibility of achieving earnings *above* the "normal" ones of the marginal enterprise, differential with regard to this, having the nature of income, given precisely by the difference between market price and unit average cost, is a characteristic of perfect (but not ideal or full) competition; *b)* in the case of monopoly, the possibility of further increasing earnings or profits is presumed. This would result *also* from the difference between price and marginal cost which, like average cost, will always be lower than price. It is *also possible* that the average cost, at the point of equilibrium, is higher than the marginal cost if the point of equilibrium is located in the decreasing branch of the two curves.

I express these characteristics through the diagrammatical representation that follows, for simplification tracing the lines of demand and of marginal profit *pm* as straight lines (equal at the point of equilibrium to marginal cost that in this graphical hypothesis results in being lower than *cmd*, that is to say of the average cost).



Figura 33.

Therefore: 1) the quantity OQ' offered at the equilibrium price PQ' , compatible with the maximum earning or profit $GG'PM'$ for the monopolist is lower than the one which, in a competitive regime, could have allowed the balancing of demand and supply (OQ).

The intersection between the marginal profit and marginal costs curves, where

$$\frac{dR}{dx} = \frac{dC}{dx}$$

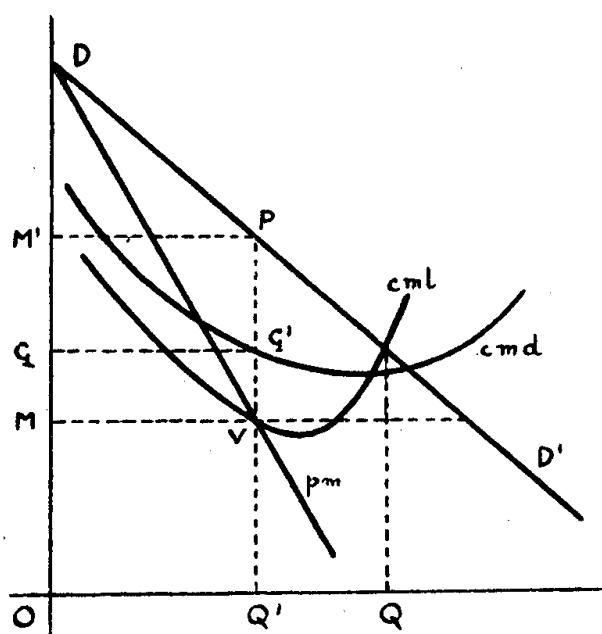
that is to say, of marginal equality, determines in fact the quantity offered even when this is not identified through reasoning, as will be done later, on the basis of overall quantities.

In considering the intervention of the fiscal event as a collection that induces the monopolist to review the elements of the calculation of monopolistic earnings, it is presumed that he has *already* achieved the condition of maximum utility through infinite attempts represented by the adopted prices and the correlated reaction of demand and costs.

A demonstration that has a particular impact in the immediate perception of the reader is that based on *global* rather than marginal quantities, in relation to *different* fiscal constraints that are illustrated as hypotheses.

Indeed, the reference to the figure that expresses the characteristics of the condition of equilibrium in a regime of monopoly, to analyse the effects of the collection of the tribute, is only useful in highlighting the variation in price. This, however, is also apparent from the demand curve correlated to that of total income and of net earnings or profit, in the geometrical demonstration that follows. The influence in the mode of variation of the marginal cost is reflected in the trend of total cost, from which it is derived.

On the other hand, by *definition*, the equilibrium price in a regime of monopoly is that which has the property of maximising the difference between *total* income (R) and *total* cost (C). Let's use x to define the quantity produced, and $p = f(x)$ to define the unit price, $R = xf(x)$ for total income, $C = F(x)$ for total cost. This leads to the equilibrium for the monopolist when the difference between R and C at its maximum, in other words $xf(x) - F(x) = \text{Max}$.

The most immediate representation of this condition is achieved by using the one that has become traditional and was made familiar by Jannaccone, Barone and others, the one which was used

in the previous lessons. It is useful in giving a clear vision of the effects of the imposition, disregarding the effects of public expenditure¹⁹¹.

- Let RR' be the total income curve;
- Let CC' be the total cost curve (whose trend reflects that of marginal and average costs);
- Let dd' be the demand curve, along which can be identified the infinite attempts of the monopolist starting from high prices through to progressively lower ones, from left to right.

The total income curve will result in an initial increasing up to the maximum point T , and then it will decrease. This is the simplest hypothesis of the trend of demand, which assigns a single maximum point to the curve of total income.

To determine the net profit or earnings, it will be necessary to compare the total income curve with the total cost curve. It is clear that, for increasing quantities, the total cost will increase (even if the unit cost will decrease).

Proceeding by differences of the respective ordinates, the net profit of the monopoly curve will be derived by the two previously mentioned ones. This curve, indicated with PP' , will have a maximum point (Cournot's point) where the parallel to the x-axis is tangential to the same curve (M). (The corresponding point on the curve RR' is to the left of the point of maximum gross revenue or total earnings).



Figura 34.

In M the second derivate is negative, in other words

$$\frac{d^2}{dx^2}(R - C) < 0$$

from which

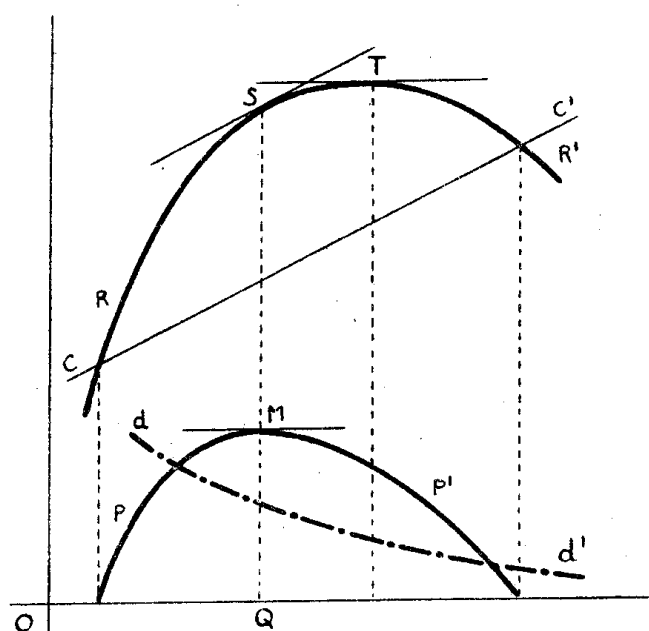
$$\frac{d^2 R}{dx^2} < \frac{d^2 C}{dx^2}$$

that is to say, the marginal income increases less than marginal cost.

¹⁹¹ On the other hand, in the most rational and modern theoretical visions of pure economy, also quoted here, earnings are also represented in a regime of competition, using the income and total cost curves.

Having traced, as we have said, the net profit curve, we postulate that it is characterised by the following conditions:

a) that at every price corresponds a profit according to the development of a *continuous* function; b) that profit follows the trend of a *curve* that is *increasing* (and differentiable) as *sale prices decrease, before reaching the maximum point*; c) that the *rate of increase* of profit is *decreasing*, before reaching its maximum point.

Having said that, again for convenience of study, we will again represent only the net profit curve, with a single maximum point, constructed by differentiation of the income and costs curves.

We introduce the hypotheses of taxation of the monopolist through a *tax* that is: a) *fixed*, regardless of the quantity produced and the corresponding net profit



Figura 35.

In this case the monopolist does *not* have an interest in reducing the quantity produced, increasing the price and reducing in consequence the consumer's surplus. The net profit will be reduced by the same sum regardless of the quantity produced. Indeed, the tax will be represented by a line ss' parallel to the x-axis (or the quantity axis) (Fig. 35).

In this case the tax *is not transferred* to the monopolist but it affects him. Clearly, if it were of extent equal to that of $C'R$, it would clearly absorb all of the monopolist's profit.

b) Analogous conclusions apply in the case that the tax is *proportional* to the net profit. This tax would not induce the monopolist to move away from the point of maximum profit and therefore to modify prices and quantities produced.

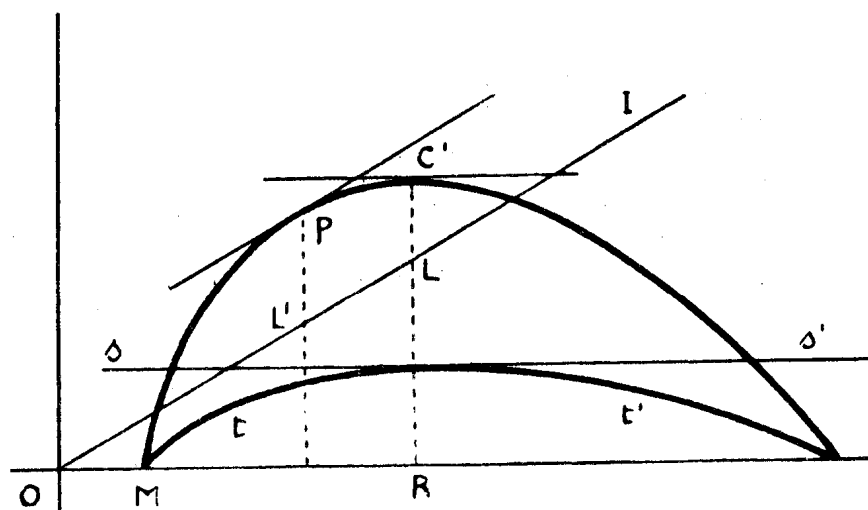
It is true that the possible attempt to raise the price also has, in addition to the consequence of reducing net profit, the fiscal repercussion of reducing the burden of the tax because it is hypothetically proportional to the net profit. And this is reduced by the increase in price. However, such *advantage* of fiscal origin will *always be lower* than the loss that derives from the possible abandonment of the position of maximum profit (*Cournot's point*). If 100 was the maximum net profit before the introduction of the tax of 10%, the possible attempt to raise the sale price (let's assume from 5 to 6 units per ton) will have the effect of reducing the net profit from 100 to let's say 80, in relation to what we have said before. In consequence of this the tax will be reduced from 10 units (profit of 100) to 8 units (profit of 80). However, the loss of 20 units is clearly greater to the advantage of a reduction of 2 units in the burden of the tax. In brief, if two profit levels differ because one is higher than the other, their residual values net of the tax at a constant percentage will differ in the same way. The graphical representation is realised by tracing a curve tt' that intersects in a proportional manner the ordinates of the profit curve: the curve represents in fact the trend of a tax proportional to profit.

c) Finally let's make the case of the tax that is *proportional to the goods sold*. This will be represented by the straight line Ol , which has the effect of reducing the net profit at the quantity (in

ordinate terms) included between itself and the profit curve. In the case that the monopolist has reached the position of maximum profit, to which corresponds the sale of goods equal to OR , the monopolist's net profit will no longer be RC' but $C'L$.

When faced with this situation the monopolist will have to consider the extent to which the consequence of the possible increase in sale price (for the purpose of attempting shifting) is in fact a decrease in net profit; however, as the tax is proportional to the quantity of goods sold, which decreases as price increases, he obtains an advantage that compensates for this loss. The elasticity of the demand curve and the trend of the cost curve have an influence on this calculation, as we will see later.

“It will therefore be of interest to the monopolist to increase the price over and above the old one up to a new limit: at this point the loss of net profit (gross income less total cost, which decreases with the increase of the price beyond the older maximum point) is exactly offset by the benefit deriving from the decrease in the tax” (Edgeworth)¹⁹².

The solution to the problem is achieved in an unequivocal manner by a mathematical calculation, as we have hypothesised the continuity of the variation of the curves in question. It has been by now demonstrated that, *among the infinite possible prices* (greater than the one that gave rise to the maximum net profit before the introduction of the tax), there exists *one which allows the monopolist to retain a profit net of the tax that is greater than the one he would have retained if he had not attempted to transfer the same tax*. In fact, in restricting the quantity produced by increasing the price, the monopolist will reach a new point of maximum profit net of the tax. This point will be to the left of C' , and precisely in the point of the curve where the distance, in the sense of the ordinate, between the profit curve and the straight line representing the tax is at its maximum (P). This point will be geometrically identified by the tangent to the net profit curve parallel to the straight line of the tax: it is in fact in that point that the difference between net profit and the tax due to the State is at its maximum, where $L'P$ is greater than LC . The price will normally increase *in a different manner* from the way in which the amount of the tax increases. The increase rate could be *the same* if the rate of decrease were to be equal for the curve of demand and of marginal cost. (Villani, in the “Riv. Ital. di Scienze economiche” [Italian Review of economic sciences], 1941).

There are, however, *exceptions* to the theoretical uniformity expressed above. The same Edgeworth, referring also to Cournot, stated: “When it is not possible for the monopolist to increase or limit his production at will”, “generally speaking he will bear the tax”. The example of the second hypothesis is that of the proprietors of building plots (urban land) who are prevented from being kept out of the market by public opinion.

In treatises about the science of finance where the geometrical representation (which here is of the type generalised by Barone) has not been used, it has been observed in the past that the solution offered here might not occur. This depended on the fact that the examples and the proof of the presumed calculation by the monopolist were based on numerical discontinuous data. On the other hand the continuity that was hypothesised in the mathematical demonstration above avoids errors and leads to a univocal solution, as has been seen.

Of course the hypothesis has been formulated, among others, that the monopolist *has already* reached the point of *maximum* profit and placed on the market the quantities that will allow him to achieve this; however, if he has not been able to produce all the quantity required to achieve the maximum net profit, in other words if he has not been able to restrict the same quantity to the limit that allows him the maximum profit, there is total incidence at the expense of the monopolist.

With regard to the influence of circumstances where there is: (a) *elasticity of demand* and b) trend of the curve of production *costs*, it will be necessary to add the following considerations:

a) Some authors have considered the elasticity of the demand curve at the *point* of equilibrium, others the elasticity *to the left* of the point of maximum profit without the tax.

Returning to the case of the tax proportional to the quantity produced, it has been demonstrated that *shifting* is *greater* for the monopolist when demand tends to be *rigid* (or how much less elastic it is) with regard to the equilibrium prices.

¹⁹² *La teoria pura dell'imposta [Pure theory of levies], op.cit., pp. 314-315.*

Considering the elasticity of demand to the *left* of the point of maximum profit, it can be said that “a given tax tends to move the *new point of maximum utility* (*net* of the tax) all the more to the *left* of the initial Cournot's point the more the demand is elastic (determining greater incidence on consumers). This conclusion is on the same logical linea at which have arrived those who have examined the trend of elasticity, not along the point of equilibrium, but along the curve: that is to say the variation of price (shifting) is all the more relevant the less elasticity of demand increases as the price increases.

b) With regard to the influence of the law of costs, it is necessary to consider if the point of monopoly before the tax was located either (Barone) “in the field of *increasing costs* or in that of *decreasing costs*” for the monopolist. In the second case there is a greater shifting onto consumers than in the case of increasing costs. In the case of *increasing costs*, indeed, the *profit curve* to the left of the maximum point *decreases more rapidly* than in the case of decreasing costs. Given a tax, the *repositioning* of the *new point* of maximum profit *net* of the tax (to the *left* of the initial one) is *greater* in the case of *decreasing costs* than in the one of *increasing costs*.

Generally speaking therefore, *elastic demand and increasing costs* tend to make *shifting less tortuous*, while an essentially *rigid demand and decreasing costs* contribute to making the shifting of the tax on the quantities produced more relevant.

B) Let's now consider the case of the *progressive tax* proportional to the *profit* of net earnings achievable in the *individual* fields of activity, in market conditions characterised by monopoly, mainly, or by imperfect competition or by intermediate hypotheses.

The theoretical case cannot be studied by framing this mode of distributing taxes in the explanation that, from an economic point of view, has been given about the progressive and personal imposition:

1) the logic of the relative contributory capacity can be useful in explaining cases of this type; 2) sometimes it is a matter of modes of extraordinary imposition, dictated by the urgency to obtain new revenues; 3) at other times it is an issue of social policy averse to monopolistic *trusts* in countries whose competitive economy, with minimal constraints and prices close to marginal costs, represents the ideal compatible with the maximum collective wellbeing; 4) in other cases it is a matter of progressive taxes on incomes from single sources (for example on land, buildings, industries, to “persuade” proprietors and entrepreneurs, reluctant to accept a collectivistic system of abandonment of private property, to comply with a system that is the result of social revolution, etc.).

In abstract financial economy, and disregarding specific and direct exemplification drawn from possible corresponding real cases, if this hypothesis is put forward, it cannot be considered extravagant for the preceding reasons: indeed pure economic theory will keep this hypothesis in mind, as economists do nowadays for the study of the properties of equilibrium in such an abstract case.

Let's presume therefore that the tax varies according to a rate increasing in such a way that, as profit increases, the *maximum* obtained by the entrepreneur before the imposition – rather than staying the same, net of the tax, with respect to preceding and subsequent points as for the proportional tax – becomes a *minimum* net of the tax.

As this is a curve (before the tax) with only one maximum point, hypothetically the reduction caused by the tribute with a strong progressive character, given the trend of the same curve, will determine two maximums, to the right and to the left of the point that the same tax has reduced to a minimum, as can be seen from the figure.

In this representation: UQ is the maximum profit before the tax; $U'Q'$ and $U''Q''$ are the (equal) maximum points respectively to the left and to the right of the minimum point uQ caused by the tax; VQ is the (single) maximum point net of the tax proportional to the net profit, with trend RVL . For the monopolistic entrepreneur, in *monetary* terms, the choice of $U'Q'$ or $U''Q''$, respectively as the result and the end of his own activity motivated by his personal profit expressed in objective terms, becomes indifferent. The sale price $p'Q'$ corresponding to OQ' will be greater than pQ (before the tax) and greater than $p''Q''$ obtained with OQ'' . We have, however, seen (in the chapter about progressive imposition) that the entrepreneur or producer cannot be directed, in his actions, by the objective of achieving the maximum net monetary profit: as we have seen and how we will see later, this is the objective of expressing a “captain of industry” mentality, of the operator aiming to impart to his

character the social “weight” that is directly in relation to the dimensions of his own enterprise in terms of capitalistic force applied (financial concentration) or numerical extent of the workforce employed, who loves risk (in relation to crisis, etc.), which implies large scale production, etc., such as that represented in the graphical representation by OQ'' (with respect to OQ).



Figura 36.

It is possible, however, that he might be a person who loves “quiet living” and who, at parity of monetary net profit able to be withdrawn, prefers to limit the quantity produced after the progressive imposition to OQ' . It is a depressing effect that the fiscal legislation of the type presumed exercises on the mentality of whoever gives priority to his own personal profit in terms of monetary profit, but which determines (presuming the demand curve is unchanged) $p'Q' > pQ$ and *partial shifting* of the tribute considered. The hypothesised progressive tax, in relation to the x-axis, is represented by the dotted line RZL such that $ZQ = uU$.

However this “choice”, which is *indifferent* in hypotheses of unconstrained atomistic economy where every decision is left to individuals, may not be so when the State is interested in the social repercussions of the activity of private individuals. It is one of the ways of considering economic constraints introduced by the governing class in the field of market economy, for example, with the purpose of causing a condition of maximum *employment* of the work factor, and of factors relating to the trend in production, price reductions, etc.

In this case and with this objective, which is considered as an hypothesis in visions of general equilibrium in the light of Keynesian-type theories indicated in the *Introduction*, the State can pursue simultaneous objectives: α) reduction of the profit for the monopolist and of the price for the reasons exemplified above; β) maximum employment of the work factor on the basis of independent and simultaneous reasons. These reasons can, in fact, consist in causing a greater effective demand through employment to re-establish the equilibrium in the cyclical context of savings and investments to avoid the criticism of the system (pure market economy) when it gives value through its functionality to the sophistry (which has also been an historical factor in the period of the “great crisis”) that emerges from the *possibility* of producing goods, offering employment and increasing consumption which is in real contrast, or could be so hypothetically, with unemployment and the contraction of income and consumption.

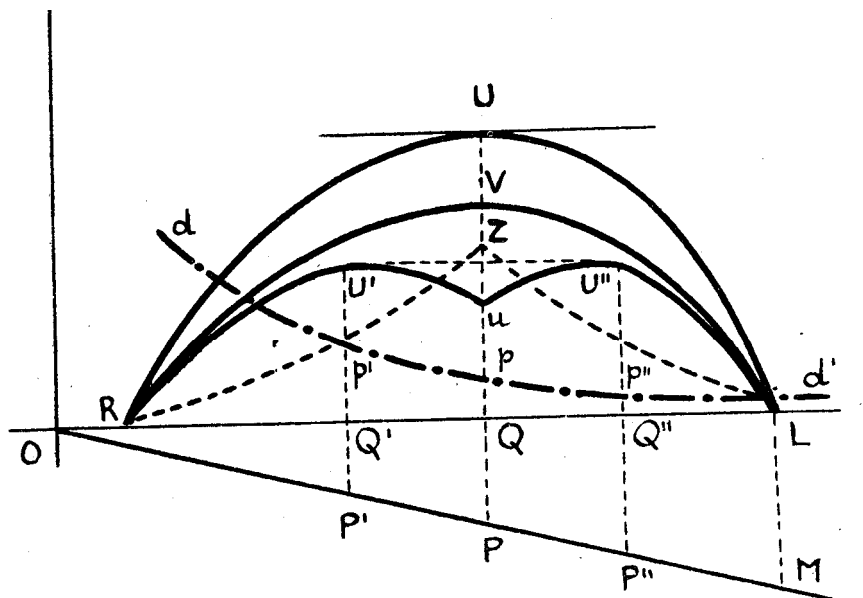
This is a hypothetical moment that induces us to consider rationally the arguments with regard to the *public expenditure* factor, in the shifting process, and modify it in so doing. I refer to the supply of a production *premium* to the entrepreneur, the value of which in a limit case can be drawn from the revenue of the same progressive tax on the net *profit* (or from other revenues of progressive tributes

on people with high incomes or to public borrowing): however this is designed as a premium proportional to (or also progressive with the increase of) the produced *quantity* and so reducing the price at level $p''Q'' < pQ < p'Q'$ for the goods in question, in relation to the trend in demand). (We presume the variation of prices, caused by the achievement of this premium as a sum to be spent by the State, to be relatively negligible).

In the graphic representation the premium is represented – in the case of a premium proportional to the quantity produced – by the straight line OM , that is to say, by the ordinates projected by OM on OL , to which we give a positive value in the economic equilibrium of the entrepreneur in this conventional construction.

Given the *independence* and also the *simultaneity* of the presumed State objectives, it is necessary that public expenditure, which translates into a premium, is such as to suppress the indifference of the producer's choices at parity of net profit (two maximum points of equal numerical values). This indifference could similarly lead, as we have seen, in a probabilistic way and depending on the psychological approach of the subjects, to the quantity offered OQ' and to the quantity OQ'' simply as a consequence of the collection of the tax.

Therefore the univocal and certain choice that is intended to be caused must rationally conciliate the State vision of the collective interest or wellbeing (in terms of greater production, lower cost, maximum employment, etc.) with the individualistic one of the producer to whom the hypothetical progressive tax is charged on the basis of monopolistic profit, when he reasons by assumption on the basis of *only the monetary and objective quantities* [and where he wants to make them determining in the convergent sense in which the psychology of “captain of industry” works.

As this simultaneous and coherent existence of objectives and effects takes place in the context of a hypothetical experiment (and in terms of an approximately corresponding phenomenon), it is necessary for the effect of the supply, as State expenditure for production premium, to be the supply by the monopolist of a quantity OQ'' , in our example and generally, greater than the equilibrium one of OQ before the introduction of the tax.

C) The traditional conclusions which appeared to be obvious because based only on objective and monetary quantities on the basis of the unchanged demand curve, etc., have been attacked as being “false” and “deceiving” in terms of the clear vision of the theory of taxation and of *employment*.

In particular, Boulding expressed this thought¹⁹³, which does not seem to be isolated, and not only because Tintner cooperated to give a geometrical illustration of the assumption of his North American colleague. Above all, the reference to the hypothesis, which has already been considered in terms of premises of the progressive imposition and in the previous paragraph, creates divergence of conclusions: that is to say, in this case it is not only the monetary variable, in which the maximum profit of the monopolist is expressed, that determines the problem, but also the search for a maximum constrained by subjective preferences, in the context of the satisfaction offered by the organisation of production and its consequent volume, and generally the pleasure of carrying out the activity of entrepreneur or employer, such as “captain of industry”, etc.

I summarise Boulding's thought, as I expressed it, with the intent of critical analysis with regard to the theme “*Effetti delle imposte e teorie del full employment [Effects of taxes and theories of full employment]*”, (E. D'ALBERGO, in “*Economia Internazionale*” [International Economy], August 1948, *op.cit.*):

a) The impossibility of shifting (presumed by the well known economic analysis) of a tax on profits is based on the assumption of a (monopolistic) enterprise policy orientated towards the “maximisation” of one's own profit (in objective or monetary terms).

b) This assumption is, for Boulding, a “rough first approximation”; it is, however, so far from reality as to be misleading.

c) To clarify the author's thinking, I specify another assumption that would characterise the classic approach (of which a representation is given, reasoning on the basis of overall quantities); for entrepreneurs to be interested in reaching the maximum profit, the size of the enterprise is indifferent, unless their size influences total profit.

¹⁹³ *The incidence of a Profit tax*, in “The American Economic Review”, September 1944.

Boulding intended to analyse the behaviour of the enterprise on the basis of the following more realistic hypotheses, and “to use analysis” to prove what is strongly believed by businessmen and “denied” by economists: that is to say, that the tax on monopolistic profits can have effects on prices and on the production of the enterprise. Of course, given his premises, he does not challenge the traditional conclusion: that the tax proportional to net profit leaves the produced quantity unchanged and leads to a contraction of profit (the curve is lower in function of the tax). However, the validity of the traditional conclusion is, for Boulding, subordinate to the hypothesis of perfect elasticity of the indifference curve that expresses, in fact, the elasticity of the supply and of the “enterprise” (a term that expresses in a voluntaristic manner the “programme to realise profits”). This “*supply of enterprise*”, whose difficulty of measurement he recognises, exists and is important.

However – it can't be denied by the author who also mentions it – this represents a variable that is not taken into consideration (at least in these terms) in traditional and also in recent hypotheses in which, as Ricci says, the monopolist is presumed obedient to the “voice of personal profit”, represented in terms of monetary profit and tending to the maximum. Boulding's variable is of subjective character (in contrast with the objective nature of the one embodied by the maximum monetary profit achievable). Indeed, the author suggests two types of entrepreneurs: I) the one who is extremely ambitious to be the “captain” of a large industry, fond of prestige and power, who will prefer pushing on with the expansion of his business even at the cost of lesser profits (than those which could be otherwise achieved); II) the one who dislikes the problems that derive from the management of a large enterprise, who has other interests, avoids risks, loves a quiet life and prefers a reduced production at the cost of less profit.

It is not understood why Boulding, whose hypotheses are not challenged and which represent some of the infinite and also quite frequent possibilities in a historical-statistical sense, did not think it opportune to include these assumptions in the traditional model, which also, with the contributions of various academics, contemplates cases of non achievement of the quantity offered or produced, maximising the monopolistic profit, including for extra-economic reasons. In other words, excluding the trend to the maximum (to which apply the negatively criticised uniformities in terms of shifting), it is possible to think of other variables (including subjective ones, and some which will be mentioned now as having already been identified by other authors) that induce us to think beyond considerations of price and quantities compatible with the maximum (constrained by the hypothetical fiscal event). That is, the premises that induced Cournot and other economists to determine the problem need to be adopted or replaced – not criticised in Boulding's sense – with the necessary acceptance of their logical consequences.

Tintner's cooperation, as has been said, has led to the expression of elasticity as “*supply of enterprise*”:

a) in a positive sense (indifference curves for the producer positively inclined and considered at the point of tangency with the profit curve). It is the case of the “cautious” individual who loves a quiet life and who avoids the risks of large production. In this case the tax on the net profit *could*¹⁹⁴ reduce the entrepreneur's desire to be involved in new business.

b) The negative inclination reflects the opposite case.

c) In the limit case of the perfect elasticity of the “*supply of enterprise*”, there would be an indifference curve parallel to the x-axis, with maximisation of profit, in other words tangential at the Cournot point of the profit curve.

The case of the first entrepreneur is accentuated (on the basis of the “increasing risk”, a notion used by Kalecky) in the hypothesis in which the enterprise does not work with its own capital.

The opposed cases of production lesser or greater than, respectively, that of equilibrium *OD*, which maximises profits in the case of classic theory in relation to the maximum net profit *DB*, which becomes *DB'* after the tax proportional to net profit or earnings, are apparent in the following diagram.

¹⁹⁴ I express a simple possibility linked to the type of indifference adopted in the Boulding-Tintner model. Later I will envisage a different shape for the indifference curves, furthermore considered more appropriate to reflect the “choices” linked to the “psychological profiles” of the hypothetical entrepreneurs.

To the variations of quantity respectively from OF to OH , and from OF' to OH' , will correspond with product price variations in the sense of: I) the increase or II) the decrease with the movement towards O or towards C of the *quantum* corresponding to Cournot point (B), measured from the segment OD .

There would be a partial incidence on consumers of the proportional tax that lowers the curve of the net profit from ABC to ABC' , with contraction of production from OF to OH in case I. In case II, because of the “mysterious alchemy” of human nature, the entire burden of the tax remains charged to the entrepreneur; he would however make further efforts to increase production, with a benefit for the community.

The constancy or rather the increase in production would correspond to the collective optimum, compatibly with the fiscal constraint; in particular the premium to producers would meet this objective, with regard to employment. In any case the classic theory would mislead and, generally, appears to be unrealistic or inadequate in explaining Keynesian-type problems: this is the essence of the statement that gives life to Boulding's work and which, regardless of what the author believes, leads in any case to the formulation of the theoretical problems considered here.



Figura 37.

I put aside the reservations in my last note, where I stated that the effect of the tax on monopolistic profits *could* be that described by Boulding, to highlight hypotheses from which different or even opposite effects can be derived.

Indeed, it is sufficient to consider indifference curves that “fan out” as better corresponding to the psychology of someone who is reluctant to extend the size of the business (“cautious”) and, for this very reason, is in need of increasing stimulation (profit), as regards the “supply of enterprise”.

This particular vision of mine or one which corresponds to a psychological profile of the producer, seems worthy of generalisation¹⁹⁵.

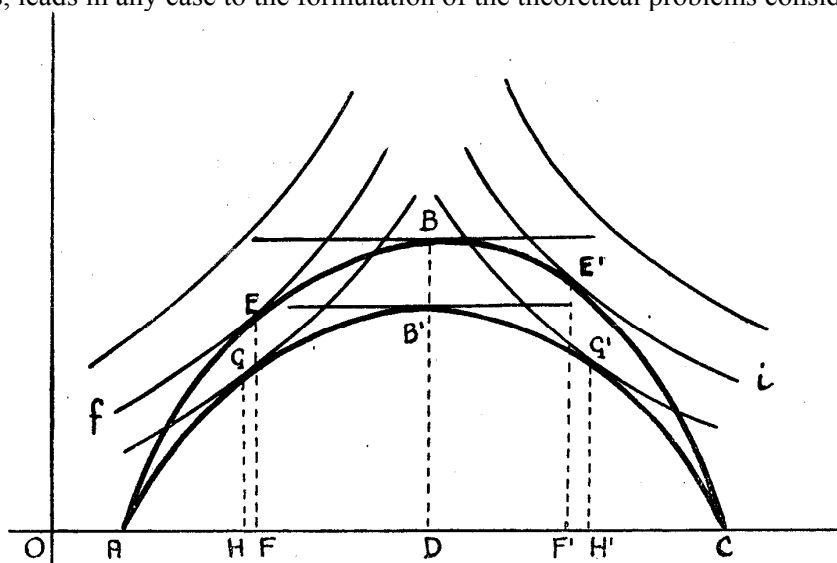
Whether this generalisation is admitted or otherwise, this mode of variation of profit represents the “efficient cause” particularly considered in my vision, which justifies the divergence of the indifference curve not only with positive inclination but also with negative inclination. In this case

¹⁹⁵ My hypothetical presentation at the Laboratory of Economy and Finance at the University of Bologna was viewed by Dr Guglielmo Gola at the same scientific seminar in this sense, that is to say, in the sense that “cautious” entrepreneurs require, as production (efforts) increase, increments of profit greater than those which, for smaller quantities (efforts) produced, give equal increment of satisfaction (with movement to the same indifference curve of a higher index). The psychological profile of the “active” entrepreneur works in an analogous manner, but in the opposite sense: with the increase of production (size of the enterprise), smaller increments of profit will be necessary for the individual to derive equal increments of satisfaction compared to that of the combination of relative effort and profit belonging to an indifference curve with a lower index.

the negative sample of variation of profits is compatible with the relative psychology of the entrepreneur who intends to increase production as long as a profit, even if decreasing, can be obtained so ensuring, precisely, a certain satisfaction.

Indifference curves had been considered as familiar and logical in the study of variations of ophelimities, with convexity towards the x-axis for some goods. With even more reason they are admissible in this field (satisfaction of the producer) where, especially in the hypothesis of monopoly, combinations regarding the supply and prices are in the domain of the will of the subject, with a field of variation wider than that which is reserved for the relationship between consumable quantities, utilitarian evaluations and needs of the hedonist consumer.

In any case, admitting this range of curves and making, for brevity, reference to the graphical representation, not only can we see verification of the effect of the decrease of quantity produced, due to the imposition on the profit of the monopolist, but also that the series of indifference curves a, a', a'', \dots with positive inclination and the series b, b', b'', \dots with negative inclination, legitimise the constancy of the quantity produced following the proportional collection of the tax on profits.



Figura 38.

In fact OF , as quantity produced, does not change with the introduction of the tax with trend $AB'C$, because the indifference curves aa'' are tangential in E and G – respectively to the curves of the profit gross and net of the tax – with the same ordinate EF .

Furthermore the divergence of degrees of inclination that I hypothesise here can be such that, representing it as corresponding to that which the curve m represents with regard to a , it even appears to be an effect of the tax to have an increase in the quantity offered of the goods in question, produced by the monopolist with the presumed psychological profile when m is tangential in H , $OK > OF$.

This tells us that, once the psychological relativity is admitted, Boulding's geometric representation is too rigid and exclusive of other hypotheses. These hypotheses deny the generalising logical conclusion of this author (and those who agree with his thinking) and lead to opposite conclusions. These conclusions are in fact more compatible with the Keynesian-type visions of the general economic equilibrium, definable also in function of the management of fiscal quantities.

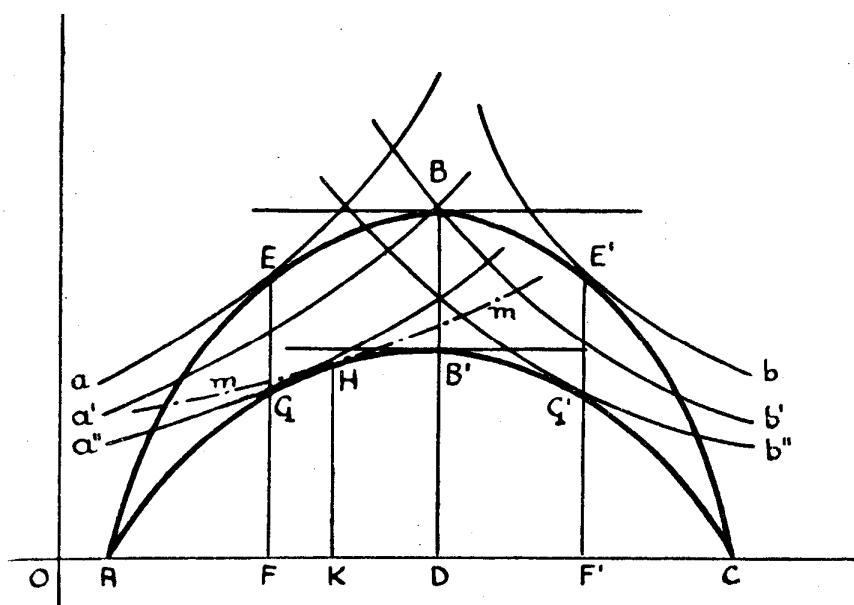
I have followed Boulding's and Tintner's approach so far to bring a critical eye to the field of their hypotheses. However, I am interested in the defence, if not the rehabilitation, of the rational and so far obvious approach (as also appropriate to the interpretation of the real world and its evolution) of the economic effects of the imposition that the authors who have been so far considered define as "classic".

Indeed what is disregarded, by insisting on the implicit and unrealistic hypothesis of the "hail tax", is precisely that State initiative or State expenditure (financed by a tax of equal extent) can

stimulate investments and influence consumption, in the case of an economic environment or market dominated by monopolistic enterprises as envisaged by Boulding. This type of enterprise becomes, in this case, the inevitably useful instrument in achieving a situation of full employment.

However, before returning to this point, I will indicate the realism contained in the hypotheses of other authors in regard to the relationships between variations of production and shifting (or effects of the imposition).

We have already considered or treated cases of (monopolistic) subjects who, without necessarily having been influenced by concerns or tastes of the type that Boulding indicated for the real economic environment (in particular the North American one), elude the remainder of their own personal profit (tendency to Cournot maximum point) and which the authors do not nevertheless claim to invalidate, but which allow us to confirm the theory of shifting.

I will limit myself to a concise indication of some hypotheses of “non-maximisation” of the net profit. A calculation (not philanthropy) that leads to familiarisation with the product may induce the monopolist, especially in the short term, into extending production to a level exceeding the one immediately compatible with the Cournot maximum point. This is the case where there has been no disregard of the account of the collective interest, forecast by Marshall¹⁹⁶ of the arbitration benefit, which leads to the supply $X' > X$ (at a price $P_1 < P_0$, this latter one presumed typical of the equilibrium in a point maximising profit).

a) Even when facing another type of tax (on goods), a rather realistic case of conflict is envisaged by Barone: the producer who, when the tax is charged, cannot manage to reduce production (*Principii [Principles]*, paragraph 368) so that he can reach the maximum profit compatible with the tributary constraint.

b) Wicksell suggests the case where, in fact, the price is not adjusted and therefore, at parity of elasticity of the demand curve, the quantity offered is not modified: among other reasons, this happens because the saving (in terms of saving of tax) that the monopolist can realise is small. This is also a realistic approximation of the traditional theory, in practice (*Saggi di finanza teorica [Theoretical finance essays]*, chapter II, in “Nuova Collana di Economisti” [New economists series]).

c) Studying the flexibility of prices in a monopoly regime, in the North American environment, the land of monopolies, T. de Scitovzsky mentions subjective costs met by the entrepreneur, alongside the objective ones. Among other examples, there is the fear of political reactions or public opinion, provoked by profit “maximising” behaviour: a condition (of maximum) which needs to be limited, with the warning that the results of the theoretical investigation have to be integrated by these subjective constraints to action. They recur in different terms in Cournot, Seligman, Pantaleoni, in the modern treatises of Bresciani-Turroni, Demaria, etc., alongside the fear of the arrival or entry of new competitors, or the hope of appearing to be or feeling morally coherent with beliefs of political systems (corporate, according to Da Empoli), with influence on the quantum of goods, on the adopted price and movement away from the Cournot point of “maximisation” (gross and net profit and production).

These indications suggest the existence of realistic visions also in the context of theories which lie outside a direct vision of social optimum and, nevertheless, teleologically reducible from the point of view taken into account by academics of employment issues.

In other words: the limit case, presented in respect of the coherent theoretical use of all the possibilities that are permitted to those who find themselves in conditions of total monopoly, has value in terms of formulation of trend. This observation does not fail even when confronted with Edgeworth’s statement¹⁹⁷ that refers to a quantity that must result in the maximum, when the monopoly price is determined by the condition that the net profit of the monopolist “should” be maximum. It is logical that such a final position of equilibrium comes to the mind of those who consider the interference of a tributary constraint of type kr (tax proportional to profit) or ar^h (progressive tax on net profit of the monopolist). From this derives the constancy of the quantity

¹⁹⁶ *Principii [Principles]*, *op. cit.*, paragraphs 269-270.

¹⁹⁷ In «Economist Journal», 1897.

produced in consequence of the coherent choice of the producer-monopolist, compatible with the interference of this tributary constraint.

However, the examples of exceptions and uniformities suggested in the hypothetical field by the authors quoted here demonstrate how a position of the producer-monopolist that offers quantities not rigidly linked to the condition of maximum net profit is not beyond essentially realistic possibilities. That is to say, there could be even greater quantities, due to decisions informed by various objective and subjective criteria that gravitate to the logical order of the promotion of investments, such as could be required by the management of economic quantities on the part of a single mind or collegial decision that takes into account the “employment” factor for the solution of Keynesian-type problems. This could be considered a defence of classical theory, made necessary by the criticism of modern fixers of economic and financial theory.

However, the lack of consideration on the part of Boulding and many other authors of the variations of demand due to the same fiscal circumstances (collection, expenditure) or due to recourse to public loans and, generally, to financial events that necessarily modify the quantities in the overall market, whose equilibrium is realistically studied, as well as the claim to explain the rational basis of the behaviour of businessmen, begs the question: is it legitimate? A negative response would be doubtful when we establish a relationship between the problems of taxation (shifting and effects) and problems of employment.

Already Cournot, when faced with a tax of type rI , where I is equal to a maximum value of $xf(x) - F(x)$, terms respectively representatives of the maximum gross earnings and total cost, and r is the tax proportional to net profit, had warned that such a tax “does not influence directly the price of commodities nor the production of the same, as it does not gravitate around the consumer. Its immediate result is to decrease the income or the capital wealth of the producer”. However, he believed that this collection was prejudicial to the general interest because the sum is generally used in a less profitable manner than the increase in the annual product of national wealth and the wellbeing of the population, if it remained available to the same producer [Cournot – whose argument reflects the liberalist apriorism of the time – did not suggest the current and likely hypothesis of a State expenditure that leads the demand of the taxing body totally, in part or to a greater extent towards the goods of the taxed monopolist.

He continues with the warning: “We will not examine here the effects of such a collection on the distribution of products of nature and of labour, even though this is the final object of the problems that relate to the theory of wealth”.

Also in the same spirit as Ricardo, who mentions substitution of State with private demand and for the same goods, as an effect of the tax, we have the arguments of Wicksell and other Italians, recalled by the author in the previous edition of this *Course*. For foreign experts of this subjects, it is useful to indicate that: *a)* Einaudi formulated the hypothesis that the tax paid by the monopolist feeds State demand for “the goods produced by the same monopolist”, who could somewhat increase the price and transfer the tax in part, precisely in function of an increase in the demand and offer of the product; *b)* In De Viti De Marco’s model, if the State and private individuals increase market demand due to the effect of the tax, the monopolist has an interest in pandering to this demand by increasing production, because in this way he can in part or totally recuperate the tax.

Let’s however move away from these models that are certainly (EINAUDI, *Principii di Scienza delle finanze [Principles of the science of finance]*, 1940, p. 247) rather comprehensive and compatible with the modern theories stimulated by what is considered the “Keynesian revolution”, and consider the effect of the increase in the demand of such goods, in itself (without explaining which might be the source that feeds a greater demand of the monopolistic goods whose net income is being taxed). This is the hypothesis of the rise in one of Marshall’s demand curves, which Edgeworth (*Teoria pura dell’imposta [Pure theory of taxation]*, *op.cit.*) examined precisely in order to discuss the effects of a tax on the net income of the monopolist. I make reference to Marshall’s geometrical demonstration (paragraph 266 of *Principii [Principles]*), whose curve of the monopolistic profit is related to the unit of product and considered in its point of tangency with the (dotted) curves of constant income, due to the effect of an increase in demand (from DD' to dd).

The profit net of the tax, as a unit, will result higher at Lm so that $Lm > Lh$, as OL is presumed to be constant. There is no certainty that Lg (the new price) is compatible with an overall maximum profit. However, Edgeworth has included Marshall's premise that, when the demand of monopoly goods "increases", the "average consumer" will buy more than what he would have bought before at the same price or will buy as much as before at a higher price. Therefore, in any case, OL remains unchanged or essentially $ON > OL$. Furthermore, the change in demand could probably be such as to ensure $Nn > Lh$; however the overall maximum profit $ONnw > OLhv$, as well as $Onnw > OLMv'$, as n is on a constant income curve higher than that to which h is tangent as m is not in a point of tangency.

Having made the hypothesis of an increase in demand, therefore there is probably



Figura 39.

an increase in the unit net profit ($Lm > Lh$); however, it does not exclude $Nn \leq Lh$. The shifting of the proportional tax can take place in the sense to which Jannaccone would not intend the traditional name to refer (but in the sense of an overall equilibrium with net profit higher than that of the logical moment before the imposition), even without a corresponding increase in price. In our hypothesis there is also an increase in price and shifting in the traditional sense, with the overall net profit $ONnw$ greater than that corresponding to the unit profit Lh and Lm . A particular variation of the curve demand in correspondence with Lg should be hypothesised to have tangency on m with a constant income curve with supply OL and therefore $OLmv'$ as maximum overall profit. As the text reports, however, there is no certainty of this variation. Generally speaking, the hypothesis of n tangent, $Np < Lg$ and $ON > OL$ appears to be more probable.

It can be said that the idea of the increase in quantities produced falls outside the classical model, as Boulding states. In this case too, however, Boulding does not formulate a hypothesis of the increase of demand. This idea could be correlated with a more general policy of increase in employment, up to full employment or even up to the more rational and lasting ideal of a "high" employment, as Röpke referred to it.

In any case, the expenditure (which stimulates the *inducement to invest* and *propensity to consume*) by State intervention, which also draws a greater net profit (due to the increase in the profit of the monopolist, whose demand has first been increased) could translate as a further increase in the

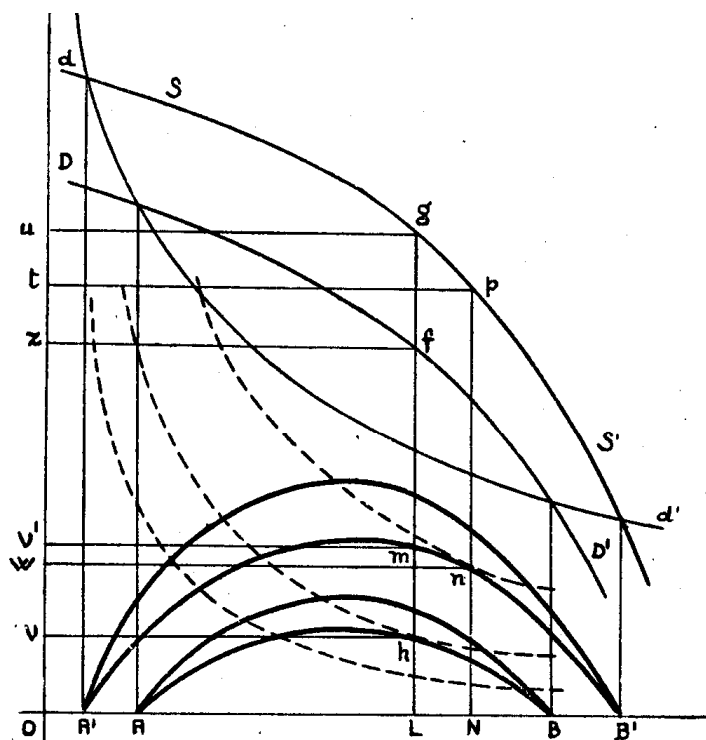
expenditure of the State and of private individuals. In other words, it is possible to qualify the source or origin of the greater public demand.

In hypotheses of extraordinary finance, Borgatta agrees with my already known hypothesis, which in fact refers to the case of consumption of the same producer goods, by replacing private with State demand, in function of the collection of tributes or other forms of enforced decrease in consumption. However the demand can also be directed towards goods produced by other groups of producers. The model can be widened without coming into conflict with the fiscal instrumentality of Keynesian type.

V.

SHIFTING IN CONDITIONS OF PARTIAL MONOPOLY

In arguing about the hypothesis of *total* monopoly, we have differentiated this from the “*pure*” one that, as has been seen, presumes control over the overall supply, over an entire market, by a single producer. This hypothesis (“*pure*”) is realised in regimes of economy entirely constrained and dominated by collective State systems. Only in this case does it not have meaning to say that the monopoly is subject to possible or potential and probably competition.

On the other hand the condition of *total* monopoly is permanently “threatened” by the shadow of the sudden appearance of competition (therefore called potential).

When the monopolist cannot effectively dominate the market with regard to the supply of its own product, and the probable danger of competition becomes the certainty of evolution of competition from being potential to being effective and co-existing, *within some limits*, through the supply of competing smaller enterprises, then the hypothesis of *partial* monopoly is introduced in the arguments.

The domain of the monopolist is then limited to a market sector of the product offered: for example, to refer to the relationship that appears in hypothetical cases numerically presented by Amoroso, as a condition which often also reflects reality, it can be admitted that a large enterprise (or a trust of enterprises) dominates two thirds of the market, upon which there is simultaneously the supply of the *same* goods or the *same* product by other, normally smaller competitor enterprises¹⁹⁸.

1) In this situation of partial monopoly, compared to total monopoly, the “power of the enterprise” is limited and the field of price manipulation becomes restricted by the *simultaneous* event of the reaction of consumers and the reaction of the competition (in addition to the trends in the cost curves in the two respective fields of production).

2) *The cross elasticity of demand*, in the meaning to which I will now refer, in the case of partial monopoly in which we consider the relationship between the price policy of an enterprise (or group acting together) and the remaining (*N*) coexisting companies, is theoretically a *finite* and a practically relevant *quantity*¹⁹⁹.

[*Cross elasticity of demand* is the relationship between the relative variation of the demanded quantity of goods *y*, following a (relative) variation of price P_x of goods *x*, when price P_y , of *y* is constant.

In symbols:

¹⁹⁸ This situation can be spontaneously created on the market, in the context of industrial concentration, or can be partially determined with the introduction of *constraints* by the governing class. One example can be found in the legislation that introduced the control of the authorisation of *new* industrial plants and that would aim to have larger dominating enterprises live alongside smaller ones, to whom a part of the market is so reserved.

¹⁹⁹ The concept of *cross elasticity of demand* can indeed represent – according to what is attributed to Kaldor – a mode of differentiating market conditions from the point of view of the quantitative relationships between the action or the behaviour of an enterprise and the remaining companies presumed to be actually coexisting or as virtual or potential, depending on the specific case. The *cross elasticity of demand* is *null* in conditions of perfect competition and of total monopoly, as is clearly evident from the definition of the same conditions.

$$p_x E_y = \frac{\frac{dy}{y}}{\frac{dp_x}{p_x}} = \frac{p_x dy}{y dp_x}$$

In the case examined here it is clear that this concept must be adapted in the sense that x and y refer to the same *homogeneous goods*, offered by a partially monopolistic enterprise (x) and by competing enterprises (y).

Furthermore, if we call P' the variation of price in a context of partial monopoly, we can write:

$$P' = f(e, s)$$

where e , the elasticity of demand, is given by

$$e = - \frac{\frac{dx + dy}{x + y}}{\frac{dp}{p}}$$

(with x part of the demand being satisfied by the partially monopolistic enterprise and part y of the demand being satisfied by the competition), and s , the reactivity of competition, is given by

$$s = - \frac{\frac{dy}{y}}{\frac{dx + dy}{x + y}}$$

which is the relationship between the rate of variation of the supply of the competition and the range of variation of the total supply.

In other words, in a first approximation, it can be said that (unlike what was the case with total monopoly), a possible attempt to increase the price by the partially monopolistic enterprise (or group of linked enterprises) to transfer the tax in the hypothetical case here can reach a lower level than that which would be predictable in a regime of total monopoly. This can be stated because the coexistence of the competition with additional supply – stimulated by the greater price attempted by the predominant enterprise – acts as a brake to the increase of the same price which, therefore, is relatively lower in *partial* monopoly regimes.

We think of the price variation as a means to actuate the shifting of a hypothetical tax on produced quantities. If these are *homogeneous (identical product)*, it must *normally* be presumed that the tax is also applicable to the product offered by the coexisting competitive enterprises.

After this premise, if the tax translates into an increase in costs, this is added to the greater marginal cost of the lower quantities offered by the enterprise (A) (if the effect of the increase in price is to reduce the quantity normally produced in a regime at decreasing costs), and simultaneously it is also added to the greater marginal cost of the greater quantities offered (at increasing costs) from competing enterprises (N), so reducing their supply within some limits.

The result for enterprise (A) will *generally* be the lesser possibility of increasing the price to transfer the tax.

For a rough and sketchy but very clear indication of the different conditions in which shifting takes place, with respect to the case previously illustrated with a geometrical demonstration for total monopoly,



Figura 40.

we can make reference to figure 35, limiting ourselves to the single case of the tax proportional to the quantity produced, deriving figure 40.

Indeed, adding the competition's reaction to the consumers' reaction in the specific market (in which previously the monopolist dominated) to make the monopolist's domain now a *partial* one, and impeding the manipulation of prices, can be seen as being *equivalent* to an accentuation of the elasticity of demand in terms of the definitive results (profit net of the tax) as indicated in diagram 40. It is *as if* curve DD' has been replaced by dotted curve dd' , with a lesser inclination with respect to the axes.

In this case the *price will increase less* and the shifting will be *less* than in the *case* in which there is *no* postulation of an *accentuation* of the elasticity of demand, an hypothesis that I have introduced to *combine* the reaction of consumers with the reaction of competitive enterprises, a process which takes place in the case of partial monopoly. (It is a rough way of giving the idea of shifting in this second hypothesis, from the point of view of the producer who partially dominates the market, for whom the preceding equivalence of hypotheses is quantitatively admissible).

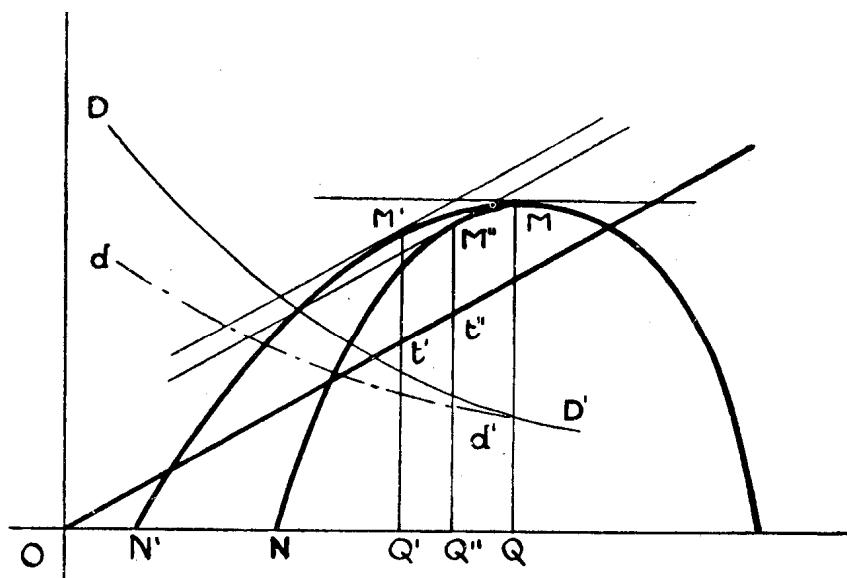
For a simple clarification of ideas, let's think again of the maximum profit curve and let's introduce an accentuation of the elasticity of demand to the left of the point of maximum profit such that the revenue curve contrasting the costs curve is modified – in relation to the presumed accentuated elasticity of demand – so that the net profit curve slopes according to MN (rather than according to MN') to the left of the maximum point.

Given the tax of the type hypothesised, a shifting at the point of equilibrium will not take place at M' , to the left of the M on the first curve, but at an intermediate point M'' on the modified curve, so that a price lower than the one which corresponds to point M' (of course greater than the one which applied in the hypothesis of the achievement of M , the maximum of maximum points, before the tax) will now correspond to it.

In the figure, the net profit left to the enterprise that dominates one *sector* of the market is $M''t'$, lower than $M't'$, achievable in a regime of pure monopoly when the only enterprise dominating the overall market carries out the shifting of the hypothetical tax. The reduction of the supply – which could be implemented for quantity QQ' by the total monopolist – is also limited to the quantity QQ'' , given the possibility of entry into the market of competitive enterprises in the sector of the supply left free.

Through an artifice which was educationally convincing, that is to say by considering that the reaction of the competition (in the case of partial monopoly or of industrial concentration in which an enterprise dominates a sector of the market) is *equivalent in effect* to an accentuation of the elasticity of demand in the case of total monopoly to the left of the maximum point, we have tried to give a

rough idea of the modification of the price and of the net profit in the hypothesis that has been considered in this paragraph, in which the price variation field is limited by the two reactions of e and s .

VI.

SHIFTING IN CONDITIONS OF MONOPOLISTIC COMPETITION

In contrast with the hypothesis of perfect competition, we should in this case adopt the qualification of *imperfect* competition, admitting the terminology that has made Robinson familiar through the quoted work. It remains that the denominated case is the most frequent in reality, in industry and perhaps even more so in commerce of every type.

However, Chamberlin's (*op.cit.*) reaction demonstrated in the series of conferences held in European universities on this subject, his objection to his point of view being confused with that of Robinson; and, at the same time, the defence of the priority due to his own concept, make us wonder whether it would be preferable to adopt this author's expression in these pages in qualifying this hypothetical case.

Indeed, the monopolistic element is considered in these pages from the point of view of the *degree of possibility of controlling*, regardless of the willingness of the enterprise (deterministic vision), and by the *intention to control* (finalistic vision) the market price and one's own supply and that of other enterprises.

That is to say, the monopolistic element effectively permeates the situations in which the supply takes place and the corresponding pure theory hypotheses. Those who read Robinson will note *comparisons* of different elements of competition and of monopoly, even though the concept of "control" of the market is not missing (see, for example, p. 10 of the quoted work).

Indeed, as has been stated above, the monopolistic element needs to be considered as suitable to qualify situations of supply, as *fused* or *combined* with the element of competition. For this reason Chamberlin, in the case of monopolistic competition, focuses on the "fusion" of theories, separate until now, of monopoly and competition (where the term imperfect competition, in addition to suggesting *conflicts* relating to the economic forces at play, also suggests the validity of the conventional dichotomy that clearly separates competition from monopoly). This is so also "unconsciously".

Given these premises in the explanation of the rational motive to prefer the concept of monopolistic competition, let's now consider its characteristics.

I) There exist numerous offerers; that is to say, there is a group in which everyone is a monopolist in "his own" market, compatibly with the competition of other enterprises from which each offerer is not isolated.

II) Every product is *heterogeneous* from various points of view: for example, in the way it is presented, the place in which it is offered (spatial differentiation), the name which marks it, its brand, etc.

Briefly: the product is *differentiated* in relation to the variety of tastes and preferences of consumers and, generally, those who demand it; that is to say (unlike the cases of identity of products considered up to now) each enterprise or "firm" has its minimum of own "individuality".

III) The general system of consumer preference gives rise, for each individual enterprise or "firm" (the term *firm* recurs frequently in this treatment by English-speaking experts), to a demand curve *inclined* with respect to the axes as an expression of the general desire for variety (Chamberlin).

IV) Every enterprise or "firm" is able from the start of its own activity, while still relating to others, to adapt and modify prices, selling expenditure (in particular advertising, to create or interpret the tastes of consumers in a differentiated way).

V) There is the possibility of "entry" into the market by enterprises that produce or offer not an identical product but a "similar" or like product, with influence on profits or revenues of the enterprises that offer the product differentiated in "its own" market, which is *relatively* reserved (not absolutely as in the case of total monopoly).

VI) The *cross elasticity of demand*, in the sense explained earlier, is positive and finite and, generally speaking, relatively more sensitive than in the case of partial monopoly.

VII) As a result, there is normally a simultaneous variety of prices and variability of production and profits, many of which can hold for short periods (or are cancelled in the long term).

(As in the limit case, it is possible to have the annulment of profits above the normal rate, or of perfect competition).

VIII) In monopolistic competition the price is normally higher, at parity of elasticity of demand, and a lower quantity is offered than in the case of perfect competition. Clearly this applies in the context of the hypotheses that we have qualified as belonging to classical theory when, studying the case of the pure, total monopoly, visions have been introduced that make the equilibrium position of the producer depend also on what has been defined as the “willingness to realise profits”.

Taking the premise of these characteristics that define the case of monopolistic competition, let's consider an enterprise belonging to a group and let's hypothesise the intervention of some types of taxes, as tributary constraints that modify and condition the equilibrium, for the time being, of the enterprise operating in the regime of supply and demand here hypothesised.

To highlight the shifting, according to the preceding models, instead of presuming the behaviour of the enterprise that acts by reducing the price – to attract customers from the other $n - 1$ coexisting enterprises – let's assume that it increases the price. The consequence, from the point of view of differentiation based on the spatial element (the location of the selling “firm”, for example), can be a loss of customers at the margin of “one's own” market, as “area” to which the characteristic control of the enterprise extends, in the case of monopolistic competition. There are customers or consumers who are closer and prefer (according to a reasoned *conflict* and not through inertia, which is realistic for the case of consumer trading) to pay a higher price rather than have to travel to a seller who is further away.

However, we can make the hypothesis in which there is no price increase: that is to say, of collection of the tax that coincides with the moment of the incidence charged to the hypothetical enterprise or “firm”.

I) For this example, it is necessary to refer to the tax not being proportional to either profit or net profit, nor gross revenue, nor produced quantity, but to a tributary constraint of the type $k = \text{constant}$, considered in Chapter VIII of the *Introduction*. The example recurs in foreign cases, denominating the tax for “the privilege of carrying out economic activity”. I have recalled Italian cases of taxes on government concessions or licences to initiate an industrial or commercial economic activity.

From a theoretical point of view, a tax of this type would increase *fixed expenses*, which impact on the first unit produced *but are not included in marginal costs*, which determine the quantity offered in a context of monopolistic competition, in the intersection point with the marginal revenue line.

If these two lines are not influenced by the fixed tax, made equivalent to an increase in fixed expenses, neither the price nor the quantity sold will vary.

There will therefore be no advanced or progressive shifting.

However, with the introduction of a tax that is considered by the entrepreneur as an increase in fixed expenses because it represents arithmetically the average of constant and variable expenses met for production, the average or unit cost curve will move from the level indicated by the curve $CC'm$ to that reached by $cc'm$ in the geometrical representation.

If the area $OQS'S$ represents the total cost of production of the quantity OQ before the introduction of the tax, the new area $QQs's$ measures now the cost of production after the introduction of the tax. The differential area $SS's's$ will represent the reduction in revenue or profit of the enterprise due to the introduction of a tax of type k , which is not transferred to consumers nor to those who offer factors of production or products for sale, (suppliers, in brief) to the enterprise or “firm” to which the tax refers, which in the graphic is in fact measured by the area $SS's's=k$.

However, even though they are directly independent of the volume of production of goods and services, taxes of this type are correlated to quantities, in practice,



Figura 41.

that have *indirect* relationships with the volume of production. Therefore, *indirectly*, through a process of accounting imputation, they can be made *equivalent* to taxes proportional, for example, to the cost of individual units produced, in the context of the enterprise or “firm”. I have highlighted cases of equivalence, for the producer, of a “single” tax to taxes on single units produced and sold (E. D'ALBERGO, *Di alcuni effetti economici delle imposte sugli scambi* [About some of the economic effects of taxes on exchanges], “Giornale degli Economisti” [Economist Journal], December 1931).

II) In this case we can move to – by equivalence: a) so as of commensuring the tributary constraint or for shifting “a posteriori” of k in ku (see Chapter VIII of the *Introduction*); and b) the economic effects – in the hypothesis of the *fixed* tax for each unit produced. As it is possible to consider the fixed tax as a *constant increment* in variable costs (whether they are seen as marginal or average costs), and referring to the curve of marginal costs, there will be an elevation of the curve $CC'ml$ of Fig. 42, parallel to itself, from the previous position of the tax to that which, therefore, it assumes as curve $cc'ml$.

The new point in which the line of marginal revenues will intersect the higher marginal costs curve will determine a lower ($OQ' < OQ$) quantity produced or sold or offered. The price will pass from P to P' on the basis of which the new maximum profit will be determined, compatible with the introduction of this type of tax: $g'v'vP' < gu uP$.

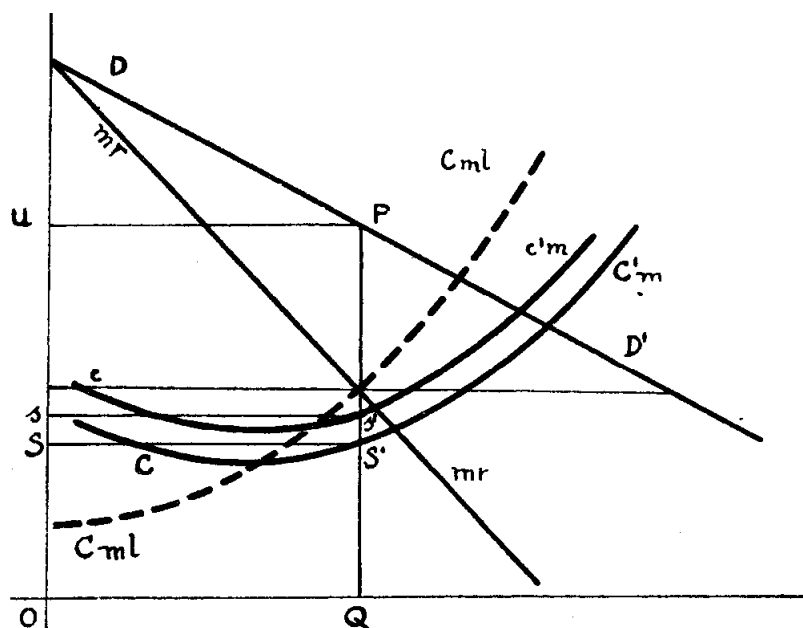
The price increase gg' will as a result be lower than the increase in cost determined by the tax, $u'v'$. The incidence takes place in part on consumers, in part on the producer as producing enterprise or commercial offering “firm”, which would also be compensated by the lower cost at which it is presumed that the lower quantities offered are produced (hypothetically presuming that the increasing part of the supply curve is valid).

We have made the hypothesis that the tax is referred to the enterprise that belongs to the group in which there are relationships of monopolistic competition and that this tax *does not* apply to the other competitive enterprises with similar products, within some limits replacing those of the affected enterprise. Clearly this trend in the elevation of the price will be higher when the tax affects uniformly all the products offered by all enterprises which coexist in markets interfered with or relatively controlled by the enterprises.



Figura 42.

In addition to “cross elasticity” of demand, the elasticity of the demand curve for the differentiated goods or products offered by the hypothetical enterprise, which acts in the group characterised by monopolistic competition, is determining in a significant way.

[In this case too there can be regressive shifting (whose uniformities we will review separately) onto suppliers of the enterprise charged with the tax].

III) We can consider the significant case in the reality of all countries, that of the value tax, that is to say proportional to the price of the product. This can be considered as a *quantity* in monetary terms, added to variable costs, *decreasing* as the value or price of the units decreases, along the line of the price or of demand. As the unit price decreases when the quantities offered increase, if we refer to the geometrical representation (Fig. 43) it can be noted that the marginal cost curve is raised with a decreasing angle of inclination and not in a manner parallel to itself with the decreasing monetary burden of the tax. The intersection with the marginal revenue curve determines a quantity offered, after the tax, which is lower than that of the pre-existing equilibrium and also lower than that which could be determined with a *specific* tax, fixed for each produced unit, as it was demonstrated in the previous diagram (Fig. 42), where the (dotted) marginal cost curve ss' , which takes into account the value tax, intersects the marginal revenue tax at z' , determining $P''Q'' > P'Q'$ and $OQ'' < OQ'$, in an analogue manner to what has been observed in the case of free competition (see Fig. 28).

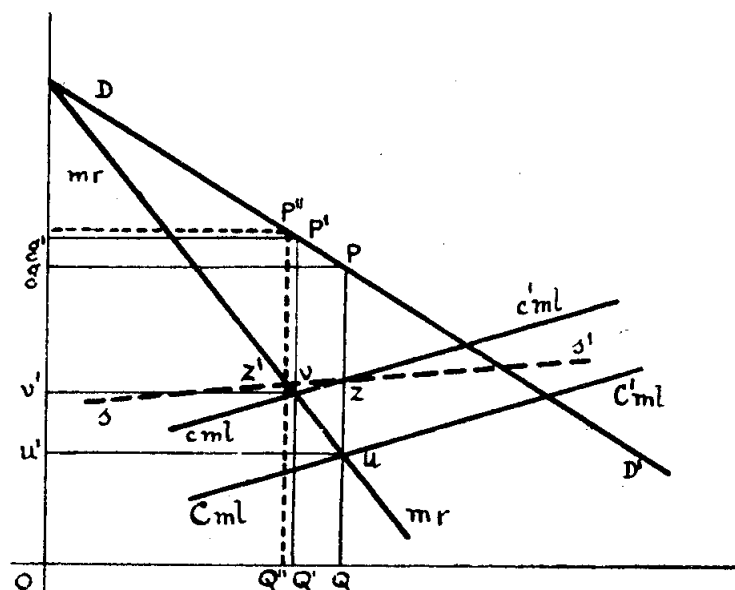
The price can increase less than the amount of the tax ($zz' < tt'$) that impacts in part on the offering enterprise, in function of the degree of elasticity of demand for the market, which it controls in a relative way for “its” differentiated product, and the cross elasticity of demand. And this, as has been seen, is different depending on whether the value tax is limited to the enterprise in question, or whether it is extended also to the $n - 1$ enterprises or “firms” of the group in which the relationship of monopolistic competition applies.

The example of retail trading is put forward in textbooks dealing with monopolistic competition. In recent discussions,

to which a future edition of these lessons will make analytical reference (for example, taking into account the arguments of M.Hall, H.Smith, E.S.Jamey and J.Hood, for the texts published in “Economia” [Economy], 1951 and 1952), there has been debate regarding the use of the illustrated case with regard to competition or monopolistic competition or oligopoly, in terms of which the probable supply by other firms represent *data* in relation to the policy of supply and of prices of individual enterprises or with regard to partial monopoly.

What is of interest here, for now, is the observation that until now we have argued, among other things, by keeping in mind that there is the possibility of “entry” of enterprises offering similar products, and that there is no agreement among firms with regard to price policy.

sell) to *ὠνέομαι* (I buy)²⁰⁰], Vinci corrects, to the “mononist”, who concentrates purchases or demand, and the monopolist, who concentrates sales and the supply. However, the first term has not yet come into common use in our literature although it is widely used abroad; so we should talk in terms of the subject who deals exclusively with the supply (monopolist) or the subject who deals exclusively with demand, or the *mononist* (and not refer to *two monopolists*, with evident terminology conflict). In the sense in which F.Vinci (*op. cit.*) uses the terms “bilateral exclusivity”, the expression *monopolist* can be admitted in the two cases.

Having made this premise, I will recall that, in spite of research by illustrious economists, from Menger to Wieser, from Edgeworth to Marshall, from Jannaccone to Pigou, from Schumpeter to Wicksell, Browley, Schneider and other modern academics, who perfect the presentation of the problem in the most recent treatises, this has not substantially modified the general theoretical conclusion reached, as we know.

This is formulated by saying that the market price in the hypothesis of bilateral monopoly is *undetermined* in economic analysis, in the sense that it is possible to contribute to the illustration of the area or field in which there are infinite possible reasons for the exchange but it is not possible to indicate *a priori*, on the basis only of economic reasons, which one will be chosen among the extremes that delimit all possible choices. This is so because neither of the two monopolists has a complete knowledge of the conditions in which the supply by the other takes place; he does not know the price and the quantity that will be respectively offered and demanded by the other, and has a different “bargaining power”²⁰¹ or a different “strategy” to use an expression more recently coined.

Therefore, while extra-economic, unpredictable or probable determining factors are normally taken into account in the field of “bargaining power”, economic factors quantitatively considered can hypothetically contribute to determining the *limits* or *boundaries* of the area or of the field of possible negotiations: for example, the marginal utility of the goods ceded or the ones demanded in the exchange.

To help the understanding of what, for example, Pigou considered the margin of indeterminacy for salaries, it is useful to suggest theoretical examples that can find a more or less frequent and probable correspondence in reality.

It can be the limit case of a single person who offers one product on the market and of a single person who demands it; of a single enterprise that makes demands for (work) services and a single offerer (workman or specialist professional). From limit cases, drawing more directly from reality, we reach those not infrequent or impossible of two *trusts* that centralise respectively the demand and supply of products in the internal market, in other words, two States that monopolise the object of exchange in international relationships. The most frequent case appears to be that of monopoly, respectively of the demand and the supply of (work) services on the part of organisations (trade unions) that negotiate the agreement of a salary²⁰².

If we want to make the hypothesis of work, as exchanged service that frequently in practice adds value to the condition of bilateral monopoly, we can say that on the basis of economic factors, the limits or the boundaries of the area of contracts are determined by the salary: *a)* (for the demand

²⁰⁰ The meaning of the noun *ὄψ-ὄντιον* (expenditure) could suggest a purchase in a translative sense and could adequately widen the concept of *ὄψ-ὠνέω* (I spend).

²⁰¹ According to Demaria (*op.cit.*) “Bargaining power can be defined as the set of tactical ability, intelligence, power of coercion of various forms (psychological, juridical, economic) by which whoever possess it tries to influence the other party in favour of the exchange relationship most convenient to him”. Cunning, organisational efficiency (the case of trade unions), etc., contribute to the success of the management by whoever monopolises an aspect of the exchange and controls the conditions of the demand and of the offer of goods and services that represent the object of negotiations.

²⁰² Demaria warns that “in the work market normally the model of bilateral monopoly applies, in part because when trade union unity is not reached by right, the competition between two or more trade unions does not have merely economic character but rather political value, in the sense of proselytism. To avoid spoiling the market, in the area of price there is the explicit or tacit agreement of the different monopolistic trade unions or the dominance of the strongest over the others” (*Principii generali di logica economica [General principles of economic logic]*, *op .cit.*, p. 428).

monopolist) by work productivity or output; b) (for the monopolist supply) by the minimum of subsistence or standard of life that the salary must ensure for the worker.

Within these limits, which we presume to be determined by the objective economic factors indicated here, there are infinite possible salaries: the equilibrium salary in a context of bilateral monopoly will, however, be fixed by the contribution of “bargaining power”, chosen among those economically viable, keeping in mind the extent and elasticity of demand and the quantity that can be offered and managed (in the event of unemployment desired by the trade union, the trade union will pay the unemployed workers on the dole).

Having made these premises, I will use the simpler representation, without recurring to contract and indifference curves.



Figura 44.

According to Pigou (who, in the Appendix to *Economia del benessere [Welfare economy]*, *op.cit.*, wanted to account for the limits of the “exploitation” hoped for by one of the contracting parties), we indicate in a diagram (Fig. 44) the work demand and supply curves, in the hypothesis of bilateral monopoly to which this author makes reference, by referring in fact to the hypothesis in which there is no competition and salaries are fixed “by negotiations between the workers’ trade union on the one side and the industrial association on the other”. In this case “the salary tariffs are no longer fixed at a single point, but there exists a certain margin of indeterminacy” (p. 400, *op. cit.*).

Let DD' be the curve for work demand on the part of entrepreneurs and SS' be the work supply curve.

If there were free competition, there would be only one equilibrium price, known in advance and identified through the intersection of the demand curve with the supply curve. More specifically, there would be an equilibrium quantity (work offered) OL , at the price or salary PL .

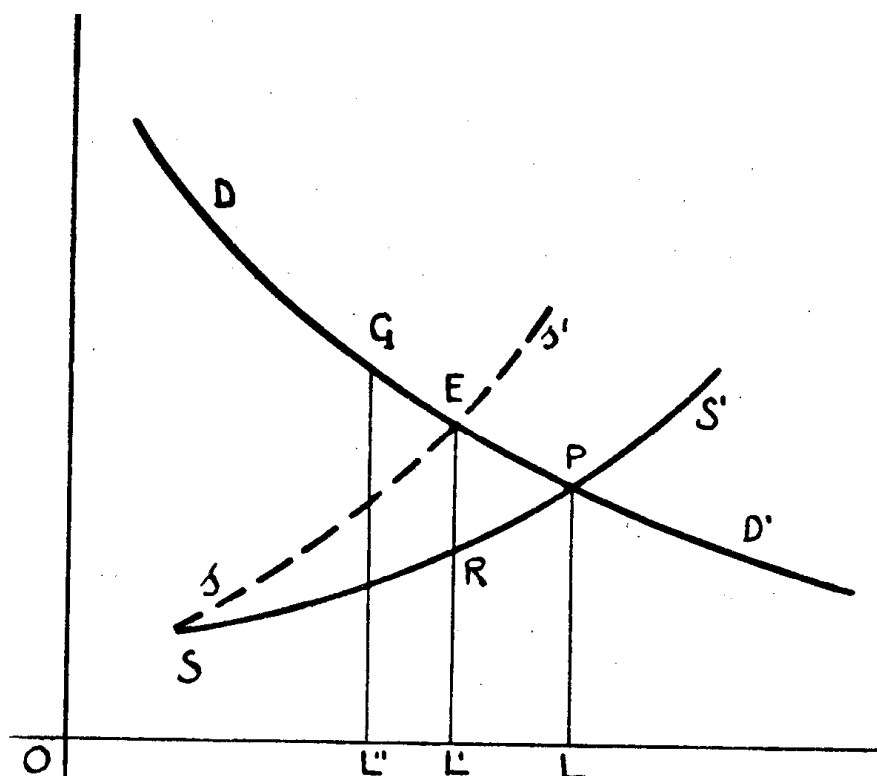
However, it has been postulated that the supply and the demand are respectively concentrated in the hands of two associations or trade unions. After this, we will therefore have not *one* salary but infinite possible ones, comprised between the points G and R . Let’s indeed now have GL'' indicate the most advantageous obtainable salary through the “bargaining power” of the workers’ trade union, and let it also represent the *maximum* one that the employers’ association is prepared to grant for the

work productivity for the quantity offered OL'' ; let RL' represent the most advantageous minimum for employers, for the quantity of work OL' and the maximum subsistence or compatible with standards of living level achieved. The *margin of indeterminacy* is covered by all samples of salary included in the interval from GL'' to RL' . Let's presume that EL' is indicated as the equilibrium salary, for the time being, by placing DD' in a relationship with the work supply curve ss' .

Let's introduce a tax charged to employers or workers, in any case proportional to salaries. Nothing can be said *a priori* about the incidence of this tax. It may: 1) impact on employers, if the management of the supply as quantity and as strategy makes the price converge at level GL'' ; 2) or it may impact on workers, if the price or salary tends to settle at level RL' . There could be a stability of work supply, in spite of the passage of salary from EL' to RL' , that is to say $OL'=K$, reasoning on the basis of the margin conceded to the possibility of absorption of revenue ER for *trade union* protection, to the benefit of another contracting monopolist (employer). The incidence can induce, generally speaking, a lowering of price (salary) beyond the minimum limit (which we presume to be represented by subsistence of by the *minimum* for an achieved and protected standard of living). In this case it would, *in the long term*, lead to an end to the work supply. Only in a transient way or for *short periods* and in view of successive demands or reinforcements of the trade union, in extra-economic circumstances favourable to this, would it be possible to admit an incidence that reduces income to below the minimum level, presumed to be represented by the slope of curve SS' .

On the other hand, the conclusions are different if public expenditure is transformed into differential benefits in favour of workers.

VIII.

REGRESSIVE SHIFTING

I will not go further in considering market conditions and the exchanges that take place within it, with repercussions on the shifting process, as those that have been presented are among the most fruitful for the objective understanding of more or less corresponding real events²⁰³.

The sense of shifting, as has been stated in the introduction to this chapter, leads to the definition of *progressive* or "forward" shifting when it takes place, for example, in the relationship between producer and consumer, that is to say when it follows the cycle of technical or spatial transformation (from the trader to the consumer) or the natural relationship which links the supply of (professional, trade, etc.) services and their demand.

In the context of the hypothesis of bilateral monopoly, however, we have already seen the possibility of a *regressive* or backward shifting in collective bargaining between entire categories of employers and workers, by going backwards in the cycle of transformation of factors or production of goods. That is to say, shifting can take place in the opposite sense to that mainly considered up to now: it can in fact be charged to those who offer "production services", production *factors* to the producer, in a wide sense, of goods and services.

Until now we have mainly taken into account relationships between producers (normally sellers) and consumers (buyers) to determine in which conditions and hypotheses the tax remains charged to the former and in which ones it is distributed between sellers and buyers, to different extents.

It is now necessary to refer with due competence, after some of the preceding incidental references, to the relationships that run in the inverse course of the cycle of transformation of goods (which we have determined to be from production to consumption), by going backwards in the economic course between the moment when products are finished and services ready to be consumed

²⁰³ With regard to the less "fruitful" hypotheses of duopoly, oligopoly and polypoly, which I will ignore in this edition for brevity and preference of more clearly determinable comparisons, for the point of view of the effects of the imposition I will refer the reader to the article by F. VILLANI (*La ripercussione di un'accisa in regime di duopolio [The repercussion of tax in duopoly system]*), in "Studi economici e finanziari corporativi" [Corporate economic and financial studies] and to the use of this and other texts by Fasiani in the 1951 of his already quoted *Principii [Principles]*, with personal observations.

to the moment of use of instrumental goods for their transformation, with the objective of arriving at the finished product and consumable services.

The factors to which we refer are prime materials, labour, capital in monetary form, etc. Once the tax has been introduced, it is conceivable that a decrease will be seen in the price of the factors used rather than an increase in costs, which is envisaged to be an immediate effect, simultaneous (discounted effect) or by hypothesis of subsequent effects: therefore a lesser cost, for this reason, in favour of producers. In this way a part of the incidence could indirectly be represented by the decrease of the price of the instrumental goods necessary for the creation of directly taxed products and services. This incidence would be reached, in fact, through a process of *regressive* or *backward* shifting.

I refer the reader to all the hypotheses where the effect of the tax was that of reducing the quantity produced and offered and suggest that, at parity of supply of instrumental goods to obtain taxed products and services, there is a decrease in price due to the lesser demand of them by the producers-sellers who bear the tax. This means that the level of the marginal and average costs, after the reduction of production due to the tax (according to what we read in Figs. 25 and 26, for example) will at a later time (or simultaneously) be *lower* than that graphically indicated. However, in particular in cases of total or partial monopoly and of monopolistic (or imperfect) competition, the argument can easily continue by presuming that the reduction of the quantity produced has the simultaneous effect of lowering the price of the above mentioned instrumental goods, with a reduction of the incidence charged to producers, and corresponding incidence charged to those who offer production factors or instrumental goods. Therefore: 1) a *lesser increase of price* of finished products, with which the forward or progressive shifting has been measured in the graph representations; 2) or a lesser reduction of net profit at parity of price measuring the shifting with their difference from the equilibrium (or prior to the various types of imposition previously hypothesised) prices.

A) To be aware of what hypothetically takes place due to the effect of the imposition, let's consider the diversity of situations that is created for the supply and the prices of instrumental goods (for example prime materials) in the theoretical circumstances considered.

Observing Fig. 45 we note the difference between the case:

I) where the quantity of the finished product or consumable service is OA , regardless of the imposition; in other words, in correspondence of the predominant tastes for that type of goods (a) there will be demand expressed by the curve dd' in the market, compared with the supply SS' ;

II) whereby the effect of the increase of the cost equal to MV , due to the tax proportional to the individual produced units, the quantity offered moves (presuming the demand DD' , compared to SS' , gives rise to the quantity of equilibrium OQ , before the tax) from OQ to OA .

In the first case the expenditure for the purchase of quantity OA , produced by the enterprise *or* enterprises to which the consumer demand dd' is addressed, was represented by $OApV$, while the quantity of residual purchasing power on the market remains unchanged and, therefore the purchasable quantity of products ($b, c \dots n$) from the other ($n-I$) or ($n-\pi$) coexisting enterprises, which we can presume to be charged or not charged with the tax.

As we have seen, when the tax is applied – second case – by hypothesis, the offered quantity *is reduced* from OQ to OA . (In case I OA was, without imposition, the *initial* quantity, relative to the demand dd' and price pA).

However, to obtain this quantity (OA), a new expenditure $OAP'M > OapV$ is required for new price $P'A > pA$. The quantity of purchasing power $VpP'M$, collected by the State with the tax, will generally be reserved for another destination in correspondence to $VpP'M$, after the tax. (I should clarify that the seller, struck by the tax, shall pay the tax to the State taxing, and that - before tax - poured over Q for the part equal to $AQPZVp$ for the demand for DD').

α) If it is a matter of instrumental goods that cannot, like prime materials, find another use or cannot find one easily or immediately in other fields at which public expenditure is aimed, their price will decrease because of the excess of the supply, and the suppliers of these instrumental goods will see the effect on their budgets, in part, of the tax that charges the finished product. This is a process of regressive shifting, so deductible after the explicit representation of the determining circumstances.



Figura 45.

β) If it is a matter of prime materials and instrumental goods that are easily replaced or used, so that the quantities that become free due to the reduction of the quantity of finished products from OQ to OA are easily and immediately absorbed by the $n-1$ (or $n-\pi$) coexisting enterprises that produce goods and services b, c, d, \dots, n , a new economic equilibrium will be established in the market, essentially without incidence onto the suppliers of these instrumental goods. As there is no regressive shifting, the incidence will be distributed between sellers and consumers of the finished product through a process of only progressive shifting.

B) Let's presume that the production factor that can find use in the production of goods offered as finished products and consumable services is *labour*.

Let's formulate the hypothesis that the labour used in the enterprise or in the industry whose product or service is affected cannot easily or promptly be employed in other activity fields:

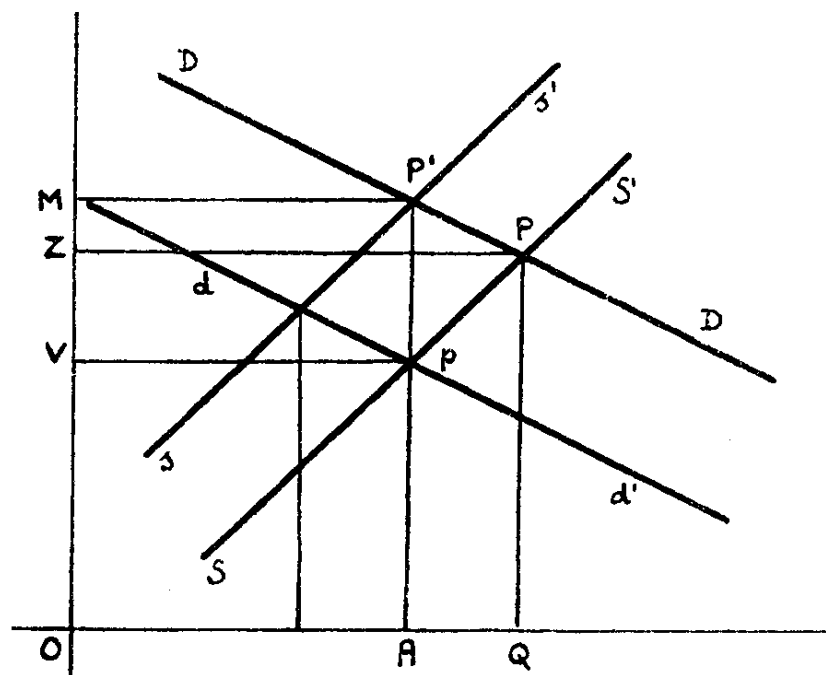
a) because it is a limit case, that is to say of rigid supply of unqualified labour or, respectively, too highly specialised and therefore, in the two cases, not easily absorbed when their occupation is reduced in a specific employment before the imposition on the production obtained from it, regardless of the use of the purchasing power collected with the tax by the State;

b) because the destination of the State expenditure (for example to services for military defence, with priority over civil consumption, which therefore tend to be forcibly reduced) creates an excess of supply of manpower in specific sectors (construction, luxury goods, etc.).

In such hypothetical cases it is possible to give value to the concept – which is generally formulated by Wicksell – of the transferability of a tax on production – which requires capital and labour in a regressive or backward shifting charged to those who offer these two factors.

[I will not consider here the less probable in the rate of interest, given the two hypothetical constraints (*a* and *b*) mentioned above, that is to say, given the multiple complementarity of monetary capital, in other words the ease of employment of it in all fields.]

The exemplification is limited to the case of the supply of the labour factor. The admissibility of the possible reduction in the rate of salaries by regressive shifting of a tax on production which is the result also of labour may be more elegantly represented, in terms of equality of effects, in the *shifting* of the tax, as Pantaleoni admitted, indifferently *for* production, or in the reduction of profits or increase in costs, here adding the equivalent possibility of a decrease of labour productivity.

I use Wicksell's graphic expression appropriately adapted to the following hypotheses for a demonstration of the backward or regressive transferability of a tax on production, as interpreted above, from the producer affected in terms of the quantity produced and offered to the salaried worker.

Let's represent the (average) period of time a certain capital is invested on the x-axis and let's presume that a number of workers are employed. Let's now represent the production obtained and the level of salaries on the ordinate axis. Presuming a given level of salaries (s), the employment of labour that will give the most advantageous result (most advantageous investment period) will be obtained by tracing from the point indicated on the level of salaries a tangent to the curve ol , which indicates work productivity on the ordinate level it indicates in terms of the level of salaries. The ordinate from that tangent point will indicate production tP in the period ot , investing capital $otvs$.

Let's presume (as has been postulated) that the effect of the tax, which absorbs a part of production (for example a third of the gross product), is that which employs the manpower equivalent to a reduction in the productivity of labour. According to Wicksell, this is equivalent to saying that the initial curve is replaced by curve ol' , whose ordinates are two thirds of the corresponding ordinates of that traced before the introduction of the tax.

Tracing the tangent to the new curve in p , we find that it intersects the ordinate axis at point s' , significant in "accounting" terms for the entrepreneur who has the bargaining power to *translate* the equivalences calculated in variations of the *reasons for exchange*. In consequence of the tax, if we formulate the hypothesis that it is comparable to the proportional reduction, from the start, of the quantity of capital-salaries used (represented by the rectangle $ss'v'v$ which goes to the State, as purchasing power that does not absorb that portion of labour, with a decrease in the rate of salaries), there is an *incidence* charged to workers to the extent of the reduction in the level of salaries = ss' .



Figura 46.

Let's presume that the politico-juridical constraints or the bargaining power of the representatives of salaried workers make possible a *partial suppression* – a phenomenon or effect mentioned later – through an increase in production due to the extension of the period of investment of a capital $ot'rs'$ equal to that before the tax: there will be an *increase in salary* but not to the extent such as to be proportional to the increase in capital $ot'rs'$. That is to say, in spite of the attempted suppression, a *partial incidence* charged to workers will occur because the level os prior to the tax will not be reached, but the tangent $s''P'$ will intersect the ordinate axis at s'' . And os'' is less than $< os$.

The extent of this reduction, which can represent a case of backward shifting on producers of services (in this case: labour) even presuming the mobility or transferability of labour, depends on the

trend of the curve that represents the productivity of the same labour and on the bargaining power of those who employ it and determine the rate of salaries.

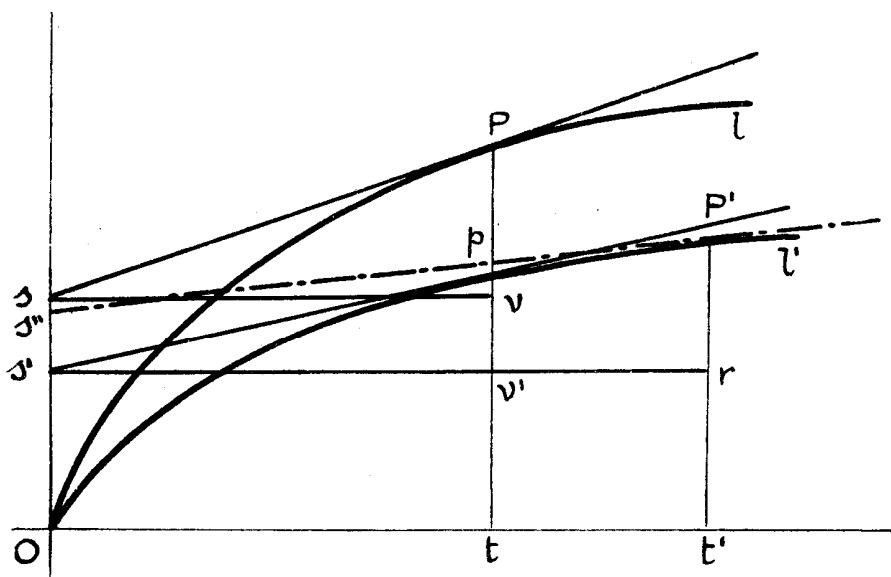
Even though Wicksell's demonstration, which I have modified after drawing it from the Appendix to the chapter on the incidence of the tax in a competition regime, had the objective of demonstrating the proportion of the incidence of a tax on the gross product, charged to the factors of production, I believe that it can be used incidentally without too much liberty, as a hypothetical case of partial backward shifting on *one* of the factors of production. This is so in the hypothesis of free competition that exists between employers and the free transferability of workers from one field of activity to another.

It is intended that we disregard the demand of labour on the part of the State through the employment of the sum collected as a tax, or we reason according to the proposition contained in letter *b*) in this paragraph.

IX.

EFFECTS OF THE IMPOSITION AND CONSUMER'S SURPLUS

There might be some doubt concerning the legitimacy not only of the scientific utility of referring to the concept of "consumer's surplus" in the context of the effects of the imposition for the purpose of highlighting the burden in terms of decrease, but also in terms of variation generally of this entity (income) due to the interference of the fiscal event in the shape of a price variation, mainly in the sense of its increase (and of the correlated decrease in the quantity offered and in the purchase of the same therefore at a higher price).

This Marshall-type category, suggested by Dupuit, which is presumed to be well known by those who have followed courses of political economy or are generally familiar with this type of study, already figured in a previous chapter on the explanation of the "public price". However, the intention to explain this institution, which occurs in public revenues *from the point of view of those offer services* and requires, (as a public body) the "public" price, influenced our discussion in the field of *objective* quantities as it was a matter of essentially balancing revenues and costs for the offerer, who presumes to have to deal with different purchasing abilities in relation, in the graphical representation, to corresponding sections of a single demand curve.

Furthermore, the burden we intend to discuss in this part of the course, in relation to the effects of the imposition, could refer not only to the greater expenditure in monetary terms that the buyers have to incur to obtain a lesser quantity of goods, for example taxed goods, compatible with the trend of the demand curve; it also refers to the loss of utility and welfare linked to the incidence of the imposition under the shape of an increase in price of goods or assets that are part of the consumer's budget.

From this point of view, other criticisms are added, other than the one relating to the "consumer's surplus" in the Dupuit-Marshall sense. These have culminated, for example in Samuelson's *Foundations of economic analysis* (Harvard University Press, 1948), in the qualification of "superfluous" referring to the concept of the "consumer's surplus". It appears to him to be neither "necessary nor desirable" in terms of the solution of some problems of theoretical finance (among which that of the preferability of the direct or indirect imposition at parity of revenue for which, as we will see later, the demonstration route referred to by this author has been adopted for some years), so that the technical and logical system of the indifference curves proves to be a more rational explicative instrument.

However, this system of preferences presented in an ordinal fashion, for example by Hicks, who has "rehabilitated" the concept of the "consumer's surplus", represents a more complete way of suggesting and essentially measuring the "consumer's surplus": not a logical procedure that nullifies Marshall's concept of the "consumer's surplus", still used in the economic field now because it is simple and inventive. It is an indication of this the fact that it also appears in the most modern treatises in English, including the one, in which Samuelson would not want to include the "consumer's

surplus". I refer to the subsequent work which contained this statement (*Economics, op. cit.* of 1949 by the same author).

Samuelson's words (*Economics*, pp.484-485) can be used to sum up a concept that is also presumed to be known to those undertaking the study of the effects of the imposition including from the point of view of the variations determining the entity called the "consumer's surplus".

As I have said, in that context he returns to what Weintraub (*op. cit.*, p.25) calls the "old literature" for the genetic explanation of the "consumer's surplus". "Each unit of goods that the consumer purchases costs him what the last unit is worth (it is intended, in the market). However, for our fundamental law (of decreasing marginal utility, most likely) preceding units are worth (subjectively, therefore) more to the consumer than the last one. For this reason he enjoys a *surplus* on each of the preceding units."

"Many ingenious systems" have been considered to measure this surplus, which Samuelson considers not to be of special relevance. The important issue is that this quantity exists and that the subject, as consumer, is prepared to translate it into money, as might happen if a seller were to say to the buyer: "either you pay me an additional amount of money for the set of units of goods you consume, or you must renounce all units, from the first to the last. Take it or leave it". "The consumer would certainly agree to the payment of a surplus of money to continue to consume the goods".

What is this then if not what in the most up to date literature (I quote from the English speaking field again with Boulding) is the most extensive differentiation in price according to quantities, in conditions of monopoly? The "consumer's surplus", or of the buyer in this case, is today defined as "the difference between what a consumer pays when there is a single price (in a perfect market) for all quantities and the maximum amount of money or income that it is possible to extract from him through a perfect or continuous differentiation in prices".

For the purpose of making the student observe how old and new definitions are equivalent, I recall the one which followed the logical path marked by Dupuit (*De l'utilité et de sa mesure [Of utility and its measurement]*, Turin, La Riforma Sociale [Social Reform], 1934) nearly 50 years before the edition of the *Principii [Principles]*, that is to say in 1844. According to Marshall "The excess in price that a person would be prepared to pay rather than do without something over the price he actually pays is the economic measure of this greater satisfaction. This has some analogies with an income but it might be best to call it a surplus for the consumer."

In the simple graph in Fig. 47, the area *CPD* measures the consumer's surplus with respect to the hypothesis of price equal to *PQ*, where *OCPQ* represents the sum effectively spent for quantity *OQ*.

Various criticisms have been aimed at this representation of the "consumer's surplus", some of which, already presented in the previous edition of these lessons, I report in the note²⁰⁴. Recalling

²⁰⁴ The great economists that had recognised Dupuit's merit in the science also put forward the objection that the sum that someone is prepared to spend for certain goods depends on the utility of *all the other goods* that the consumer might consider. Therefore the maximum pecuniary sacrifice that the consumer is prepared to make to procure one unit of a product *does not* depend only on the *utility of that product*, but also on the *utility of all other products* that are on the market; it also depends on the quantity of *pecuniary means (income)* available to the consumer, the latter a circumstance that Dupuit had neglected to consider.

Similarly, various criticisms have been levelled at Marshall that the concept has generalised and applied also to the solution of problems of fiscal character, as Dupuit had done:

a) First of all there has been the objection that in spite of the attempt to "*objectify*" the concept of the consumer's surplus (as the difference between two prices) in terms of *monetary* terms, it is not possible to overcome the substance of the fact: that is to say, that it is a matter, in any case, of a *hedonistic evaluation*, an excess of *satisfaction* deriving from the consumer being able to intensify and extend other consumptions because of the low price of a given product. Indeed the hedonistic concept is traceable (even without the generous interpretation that Jannaccone adopted of Marshall's idea) in the quoted definition of the English economist when he states that the excess of the price paid over that which we would be prepared to pay is the *economic measure of a greater satisfaction*.

However, in this case, as critics state, the monetary sum (price excess) would be the *index* of a *sum* of *ophelimities* or of *utilities* of the quantity of actual and future consumptions that a given consumer may purchase because he pays a certain price [inferior to that he would be prepared to pay for a given product (Borgatta)]. It



Figura 47.

Marshall's simplified representation, here I insist on the characteristic that is criticised to the greatest extent by the same Hicks (see E. D'ALBERGO, *Sviluppi di un teorema finanziario e sue relazioni col massimo benessere [Developments of a financial theory and its relationship with maximum welfare]*, extracted from "Studi in memoria di Guglielmo Masci" [Studies in memory of Guglielmo Masci], Giuffrè, 1943) and that I have recalled with regard to the explanation of public price: that is to say, the "constancy" of marginal utility of money or of income, which is presumed by

would be necessary to be able to compare the overall enjoyed ophelimity with the consumption of the quotas of purchased goods, and the greater ophelimity enjoyed by also consuming the goods that could be purchased with the excess in price Marshall refers to.

b) Furthermore, the *demand curve* refers to the *same consumer* or to a *group* of consumers in conditions of tastes and income approximately *equal*. When Marshall considers the surplus with respect to an *entire* market, he makes *limitative* premises (for example that the same sum of money represents equal quantities of pleasure for different people; that the diverse quantities in the market are numbered according to the desire of the buyers; that the desire of each quantity on the part of each buyer is measured by the price that he is precisely prepared to pay for that quantity) that reduce the applicability of the concept to *mass* problems, with heterogeneity of subjects and groups.

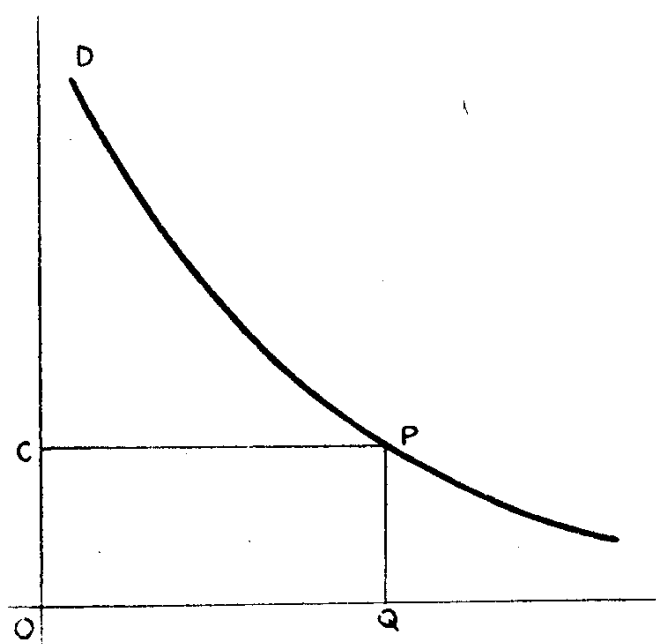
c) Marshall's concept could give the idea of *saving of money* that remains available for other consumptions, while Marshall clearly compares two alternative positions, one of which is *real* (price effectively paid) and the other being *virtual* (price that one would be prepared to pay, in other words hypothetical). Furthermore, in terms of saving of money, it *disappears* in the *budget* of an individual. What may remain when the consumer's income has been spent is the *differential utility* or the difference of the overall ophelimities that one or more consumers enjoy, comparing two positions of equilibrium characterised by different levels of prices.

d) Finally, there is the question of *terms*. Indeed "income" is a differential Ricardian concept which could give the idea of *privilege* for some *consumers* with respect to determined goods when consumers excluded from the consumption of the same goods are considered. This can happen for *some categories of goods* (those for which "fashion" is important or luxury goods: diamonds, jewellery in general) for which, as has been demonstrated by Cunningham, the *pleasure* (as the consumer's surplus) *decreases* with the generalisation of consumption of the same goods; that is to say, *it depends* on the fact that other consumers have the goods in question, in other words by the *quantity of such goods purchased by others*.

Conversely, the concept of the "consumer's surplus" according to Marshall *is not a function of the quantities of goods purchased by other consumers* and exists for all consumers, in the sense of the *surplus* that the English master chose to denominate as the *differential utility* highlighted by Dupuit.

Marshall's demonstration, based on the demand curve (and not on the indifference curves), *a constancy Dupuit did not take into account.*

For the purposes of the simplification of the problem, the artifice consists in disregarding the fact that the demand curve is determined by: 1) psychological factors relating not only to (a) the subjective utilitarian appreciation regarding the portions or units of assets or goods to which we make reference, but also to (b) the monetary income which can be destined for the purchase (which can vary); 2) in addition, to the hypothetical subsequent prices of the units of those goods (and of the other possible purchases, as I said in the note).

In particular, when we realise that we are discussing hypotheses of constancy of marginal utility of money or of income, we consider the demand of the goods *independently* from the amount (and variations) of income: in this way the normally decreasing trend of the demand curve is considered exclusively and immediately dependent on the utility curve of the goods in question. The simplification does not seem to contradict reality for very small portions of income spent on individual items hypothesised each time.

[It is however necessary to warn that this type of simplification is possible not only when the demand curve is adopted for the explanation of these phenomena, but also when we refer to the most suitable instrument to take into account simultaneously prices, available income and tastes or preferences: I am referring to the indifference curves, which I presume to be known as a means of knowledge and demonstration.

That is to say, the indifference curves can be hypothesised with the following meaning: that with respect to given quantities of goods or assets, the inclination of the indifference curves or the marginal rate of substitution is the same, whatever the quantity of money or income available to the consumer, with simplification of dependence that can refer to a very special case (PARETO, *Manuale [Manual]*, *op.cit.*, p. 260) If we express the marginal rate of substitution in terms of money for units of goods, this rate becomes:

$$\frac{\text{marginal utility of goods}}{\text{marginal utility of money}}$$

$$\text{marginal utility of money}$$

if the marginal utility of money is constant (as in Marshall's hypothetical warning), the marginal rate of substitution depends only on the quantity of goods, not on the quantity of money or income. In this way the demand for goods depends only on the utilitarian appreciation of the quantities of the same goods (and not also of money). As can be seen, with this simplification – which furthermore also uses indifference curves in violation of *their* logic – we are quite close to Marshall's one of constancy of marginal utility of money, reasoning directly on the basis of the demand curves²⁰⁵.

The simplification is against the normal vision of the relationship of substitution, which decreases when combinations of goods are considered, for example y in relation to x , to signify the quantity of y that we are prepared to sacrifice to obtain a further increase in x . Expressed in the terms

$$\frac{dy}{dx}$$

this is represented by an indifference curve where the quantity of x increases as y decreases in the combination which leaves the subject satisfaction constant. The inclination of the tangent to the indifference curve will vary from point to point, as the relative quantities of y and x vary. The decrease in the relationship of the relative marginal utilities of the quantities y and x , evaluated by the subject, leads to the decrease of the marginal rate of substitution (for example: $5/I, \dots 4/I, \dots 3/I, \dots$

²⁰⁵ We have warned that the marginal rate of substitution could be independent from the quantity of money even if the marginal utility of money were to increase as the available quantity increases, as long as the marginal utility of the goods varies in the same proportion.

2/1, ... 1/1, ... 1/2, ... 1/3, ... 1/4). Instead of the decrease of the marginal utility of a product, we have the decrease of the rate of substitution of two products, whose relative utilities are subjectively considered].

These notions, which are nevertheless presumed to be known from the study of political economy, need to be remembered to explain what the simplification that leads to the consideration of the interference of the fiscal event (charged to the goods so that it varies their price) consists of, by reasoning *directly* on the demand curve, which Marshall (and also Dupuit) kept in mind when studying the "consumer's surplus", in the sense of the definition given to it, with the restriction of the constancy of the marginal utility of money.

Indeed, the degree of elasticity of demand will decide – considering as constant the marginal utility of money or of income – the "quantum" of consumer's surplus sacrificed by the tax on the goods, or of the burden in the terms of this given mode of imposition.



Figura 48.

It is possible to draw conclusions for hypothetical cases that are considered in the geometrical representation (Fig. 48).

1) In the first case of relatively elastic demand it is apparent that the State, by introducing tax IR , obtains a revenue measured by the rectangle $IRNS$. The consumer not only loses a fraction of "surplus" corresponding to the rectangular area $MI'RN$, to which corresponds a monetary quantity for the tax, but *also sacrifices a surplus represented by the triangle ROI'* . [Dupuit considered the triangle RPI as the *utility lost* by the taxpayer and by the tax office and continued by expressing two theories: 1) the higher the taxes, the less they relatively produce; 2) the lost utility increases proportionally to the square of the tax].

Marshall continued by observing that the loss of "surplus" is small or large, *all other things being equal*, according to DD' being *more or less vertically inclined*. That is to say, it is very small for those goods whose demand is less elastic, in other words for goods of basic necessity. He expressed the *standard way to perform* according to which: "If a given sum of tax must absolutely be collected from a given class, the loss of consumer's surplus will be less if the tax is collected on necessary goods than it would be on luxury goods."

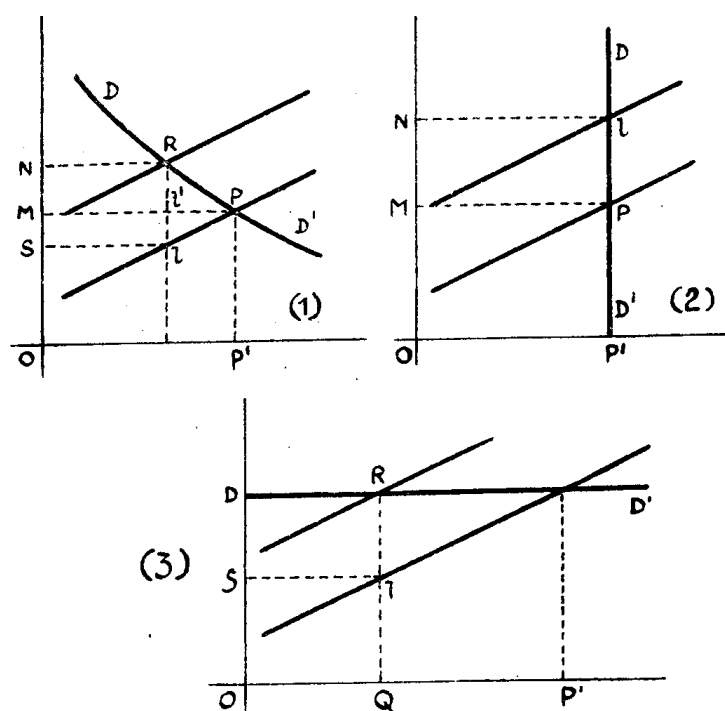
Having said this, there are the two following deductible limit cases:

2) That is to say, the "consumer's surplus" would be *infinite* in the case of *rigid demand*. In this case *any price increase would be possible*; the decrease in the consumer's surplus would be

greater the greater the rectangle $PINM$ is, whose height is given by the amount of the tax. This rectangle measures the fiscal revenue exactly.

3) *No increase in price* is possible in the case limit of *absolutely elastic demand*. No “consumer's surplus” is destroyed by the tax. However, the *consumption* of the product is reduced from OP' to OQ and it is small in proportion to the revenue that the State can obtain ($RDSI$).

Let's use the demonstration that uses the indifference curves to give an idea of the divergence between the solution of the fiscal problem (reduction of the “consumer's surplus” due to the interference of a tax on the goods considered), in Marshall's simplification (A) (which reasons on the demand curve, presuming the marginal utility of money as constant and the utility of the asset dependent only on its quantity) and (B) the normal case of decrease of the rate of marginal substitution.

Let's express the monetary income available to the individual on the y-axis and the goods x on the abscissa axis. The price line PP' , in the point of tangency S with one of the indifference curves S , leads to the identification of abscissa axis of the quantity OQ purchased. If the sum of the monetary income spent on the purchase is represented by the quantity SR , as SQ is the residual income, destined for the remaining goods represented by the money. The excess that in the vision of Dupuit and Marshall has the nature of income is represented in this model by the difference between the overall price that the subject, in possession of income OP , would be prepared to pay so as not to have to renounce quantity OQ of goods, that is to say, RT (T is on the indifference curve with the lower index, passing point P) and the overall price RS in the first hypothesis of market price. That is to say, the consumer's surplus is measured by ST .

If we presume that the effect of the tax on the goods x is to increase its price in the sense that it passes from line PP' to line PP'' tangential to another indifference curve in S' , essentially this leads to the decrease of the consumer's surplus (from ST to ST'), with the reduction of demand of x (from OQ to OQ'). The term “essentially” has been used, clearly not in reference to the case here graphically represented, given that for S' to be to the left of S (which means a lesser quantity of goods being demanded), ST must be greater than $S'T'$. The inequality, however, could also be turned upside down if, in correspondence to an appropriate trend in the indifference curves, easily traceable, which reflects a particularity of the product demand, the point S' were to be to the right of S (which would mean that the demand of x has increased with the increase in price). This is an hypothesis to be taken into consideration, also in this *Course*, in the analysis of subsequent approximations from the theoretical rational problem to the actual phenomenon (see Chapter XI, the paragraph relating to the *Pareto-Slutsky analysis of demand and the theory of taxes on consumptions*).

What follows helps to recognise the hypothetical abuse of the constancy of the marginal utility of monetary income, which focuses the attention, in the argument, on the variable represented by the marginal utility of the goods. In other words it leads to the argument on the basis of the instrument represented by the demand that, to use Amoroso's expression (*Lezioni di economia matematica [Lessons of mathematical economy]*, Bologna, 1921), represents the derived synthetical phenomenon (effect) which relates also to the function of ophelimity or subjective utility, such as the analytical phenomenon (agent of cause). However the immediate evidence of the demonstration, which is obtained by using the demand curves, is such that in the context of the equality of the *sense* of the solution (absorption of the consumer's surplus in terms of the variations of the price due to the tax), from a teaching point of view the recourse to Marshall's model (Fig. 50) appears to still be fruitful.

We make reference to it to demonstrate which variations of the “consumer's surplus” are due to the consideration of the tax on the goods as a uniform increase to average costs (respectively constant, increasing and decreasing). The previous reservations, of course, are necessary to identify, with due approximation to events, the quantitative relationships between the factors that are isolated in the demonstration: the variations of the hypotheses relative to the conditions of the supply, the tax and prices.

1) According to Marshall's graphic demonstration, in the case of production of taxed goods in a *constant costs* system, the *loss* of the *consumer's surplus* is *greater* than the *sum* that is handed to

the State as gross revenue. Indeed, in the figure, $sSaa$ is greater than $sSKa$, after the application of the tax aK .



Figura 49.

II) In the hypothesis of production of goods in *increasing costs* systems (of decreasing productivity, Marshall writes), as has been seen, the price will increase less than the amount of the tax. If this law acts strongly, generally speaking the *sum* that goes to the *State* as fiscal revenue is *greater than the loss of the consumer's surplus*. This can be deduced from the graphical demonstration (case II) where $cFEa$ is greater than $cCAa$ after the introduction of the tax aE , which raises the cost of production from SS' to ss' and reduces the quantity sold to OR .

III) Finally, in the hypothesis of taxed goods in *decreasing costs* systems, the area that in the figure represents the sum collected by the State (due to the application of the tax aE which raises the cost curve from SS' to ss') is $cFEa$, less than the area $cCAa$ sacrificed as the consumer's surplus.

Because the concession of a *premium* to producers to obtain a reduction in price works in the *opposite sense* in cases of increasing or decreasing costs – in the sense that the *earnings* in the *consumer's surplus* are less than the *amount* paid by the State to *producers* in the way of a premium in the hypothesis of increasing costs, while it is greater in decreasing costs systems – Marshall had expressed what Edgeworth – who also in *Psichica matematica* [*Mathematical psychology*] had argued on the basis of the subjective variable utility – overlooking the arbitrariness of its constancy, had named, with obvious admiration, as the quoted text indicates, “Marshall's theory”. This is expressed in the sense that *the collection of a tax on goods produced in increasing costs systems and destined for the concession of a premium to producers of goods in decreasing costs systems may correspond to the objective of maximum collective satisfaction*.

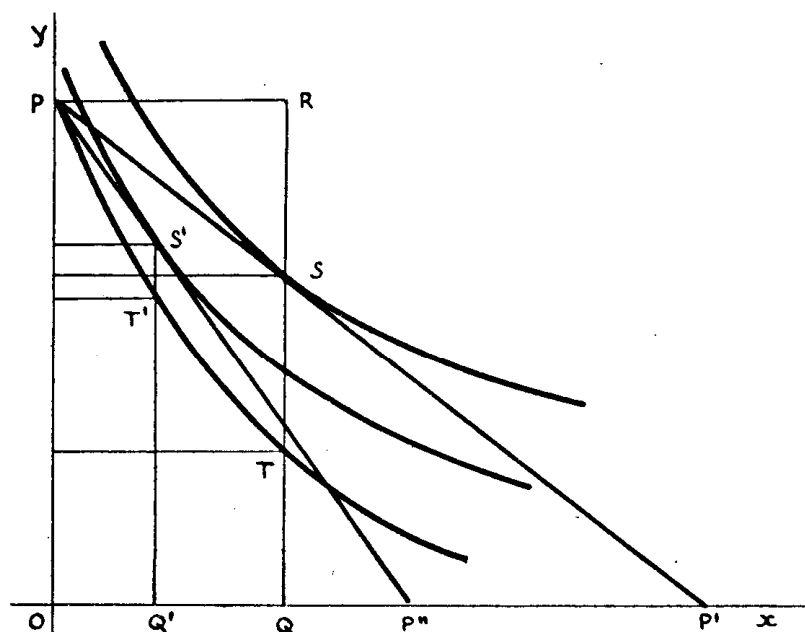

Figura 50.

This derives from the application of theoretical notions expressed earlier, considering the concept of the consumer's surplus. However, the problem is not so simple as it is necessary to take account of numerous circumstances that, in the *real case*, the same Marshall puts forward and, among others, those considered by Borgatta in the quoted article, and finally of the observations of economists with regard to comparison which should be carried out (assuming that it is rationally and statistically possible) between the utility lost by the taxpayers who bear the cost of the premium and the increase in the consumers' surplus.

X.

EFFECTS OF THE TAX ON QUANTITIES IN THE CASE OF: COMPLEMENTARY GOODS; B) SUCCEDANEOUS GOODS

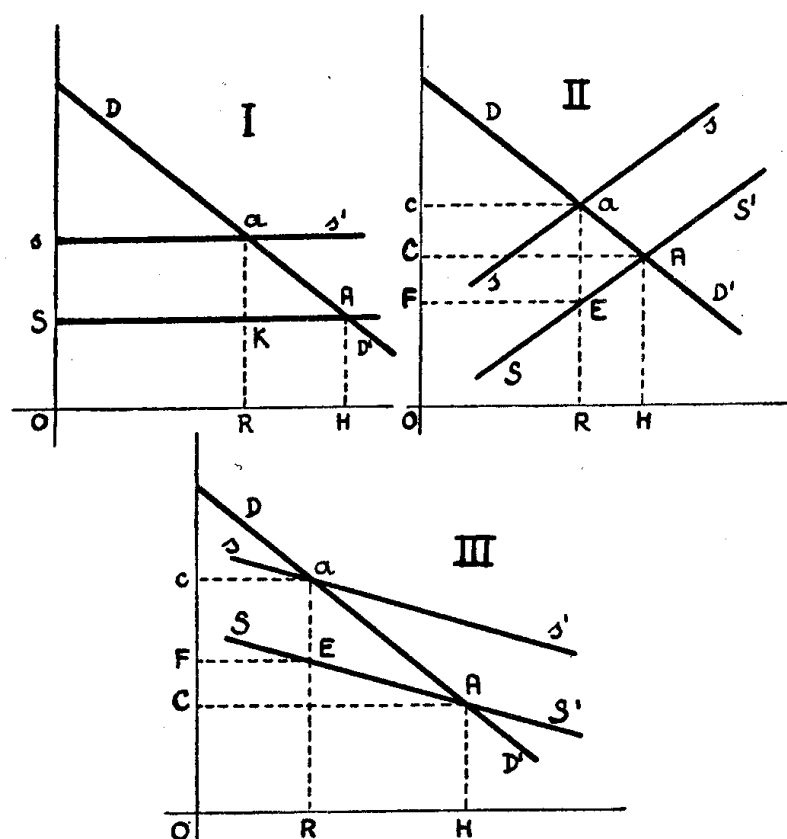
Until now we have implicitly considered, in the hypotheses of taxation of goods, taxes on goods considered to have *independent* utility, on which the subjects make separate demands. It is a hypothetical restriction which distances the real event, where normally goods are linked by relationships of complementarity in a wide sense, that is to say, in the sense that as the quantity of one type of goods is demanded or consumed so the utility of other goods also varies (increasing or decreasing).

In passing to consider the influence of the variation of costs and prices in the context of a shifting process, we reason in terms of a *first approximation* according to established theories, which disregard the *hierarchy* of goods, differentiated between "superior" and "inferior" (for example polenta, bread, meat: meat of first or second quality) and linked with variations of income, in the sense that, as income increases, so the demand moves towards "superior" consumptions.

There is an effect equivalent to that of an increase in income when the price of inferior goods decreases: in this case, instead of an increase in the demand of these “inferior” goods according to the univocal vision of the theory of demand, there is a movement of demand towards “superior” goods. The same can be said for exemptions or reductions of taxes on inferior or “popular” consumptions with respect to a greater burden of the tax charged to “luxury” goods.

No account has been taken of this, which is called the multidirectionality of demand, in international financial theory, until now. I have introduced these concepts in an essay (E. D'ALBERGO, *L'analisi Pareto-Slutsky della domanda e la teoria delle imposte sui consumi [The Pareto-Slutsky analysis of the demand and the theory of taxes on consumptions]*, “Giorn. degli Econ.” [Economist Journal], January-February 1949), taking into account Slutsky's developments of the Paretian vision of the hierarchy of assets. Similarly in pure economy Hicks completely contrasts the theory of demand in the case of “superior” goods or assets (so that with the decrease of price the quantity demanded increases: this is defined as the “replacement effect”) with the theory, developed through indifference curves or equivalents (of marginal evaluation of demand) which at first sight appears to be paradoxical: indeed, as I have said, as the price of “inferior” goods decreases, their demand does not always increase, as the greater purchasing power which is the real consequence is directed towards “superior” goods.

The introduction both of these visions (“inferior” and “superior” goods) and of the variations of monetary income (due for example to variations of public expenditure) modifies the traditional conclusions relating to the effects of taxes on goods as it conforms with the relationship between variations of prices and quantities demanded in the case of goods no longer considered independently from each other, in the consumer's equilibrium. We will therefore discuss this *in a second approximation* later (see the following chapter).

For now, let's consider the influence that the relationships of complementarity and replacement (or substitution) exercise on the shifting process.

A) Shifting of the tax in the case of complementary goods.

I) In a strict sense goods are considered to be in a relationship of complementarity when, by increasing the demand of one of them, the marginal utility of the other increases. From this derives another sequence of first approximation, in the sense that: by increasing the demand of one type of goods the price of another increases. In terms of relative prices, if the increase of the price of one type of goods leads to a decrease in its demand, the demand and price of the other type of goods will also decrease.

In practice there is no lack of frequent examples of goods aimed at a joint demand for the satisfaction of one specific need. Sugar and coffee, petrol and cars, pens and ink, etc., are linked to different *extents* by a relationship of complementarity, which can lead to a *fixed* relationship in the combination of specific goods in terms of their *joint use*.

This influences the relativity of the solutions in terms of analysis of the effects of the imposition on goods, which, for example (to study their repercussions on the “consumer's surplus”), Borgatta considered (Giorn. degli Economisti [Economists Journal], 1921). Generally speaking, given the definition of complementarity, Borgatta could not admit that “a tax which is charged to a type of goods belonging to a set of complementary goods has the effect not only of modifying the price and quantity demanded of this type of goods but also the price and the quantity demanded of goods linked (to the first one) by a relationship of complementarity”.

The geometric demonstration he gives, with Marshall-type curves, highlights in part specific variations of quantities and prices, and in part he presumes them to be implicit.

In any case, to give the *sense* of the development of the overall phenomenon, let's presume that the *combined demand* relating to two type of goods (*A* and *B*), linked by a relationship of strict complementarity, to be represented in the geometrical demonstration in question by a curve *DD'* while the curve *SS'* indicates the trend of the cost of the complementary group being examined.

[There is no shortage of actual cases of sales in a single pack and at a single price of consumer items linked by relationships of complementarity, if we think of foods in real retail markets. It is, of

course, possible, knowing the separate price of one of the two products making up the combination demanded (and offered) jointly, to obtain what would be the separate curves of demand and supply].

Let dd' and ss' be the curves, respectively, of demand and supply of product A , which intersect each other at point p , on PQ , which measures the equilibrium price of the group to which quantity OQ corresponds.

Let's presume that a tax on product (A) has the effect of increasing the cost curve from ss' to tt' , given the sum of the specific tribute of $fpf'p'$. Let's presume, as one of the possible cases, that the tax determines, *all other things being equal* or in a first approximation, an increase of the cost of the complementary group (A, B) from SS' to TT' . From the diagram we obtain: *a*) an increase in the overall price from QP to $Q'P'$; *b*) the reduction from OQ to OQ' in the overall quantity demanded; *c*) an increase of the price of A and a variation of the price of B which depends on the point at which the new curve tt' of the supply of A intersects the particular or relative demand curve dd' . In the case described by Borgatta, the intersection point of the supply curve with the demand curve of A is to the left of the line of the overall price (or relative to the entire complementary group); therefore the decrease of the quantity demanded, which would be reduced to OQ'' at the particular price dQ'' of *only product A* would be greater than OQ' , that is to say the one corresponding to the food group. This suggests that there must also necessarily be a modification of the price – Borgatta writes – in addition to that of the quantity demanded for product B (presumed not charged with the tax but linked to taxed goods or product A by a relationship of complementarity).



Figura 51.

Edgeworth states that “a tax on one of the two complementary goods will increase the price of the one affected by the tax and will reduce the price of the other which is not” (*op. cit.*, p. 292).

On the basis of the general uniformities that precede in a first approximation, this can mean that some implicit and expected phenomena can be explicitly highlighted by modifying Borgatta's representation for the demonstration:

1) Let's presume that simultaneously with the increase in cost, ascribed to the introduction of the tax and its extent, with the corresponding reduction of demanded quantity for A , a decrease in the *utility* of product B has also been determined (as required by a definition of the relationship of complementarity).

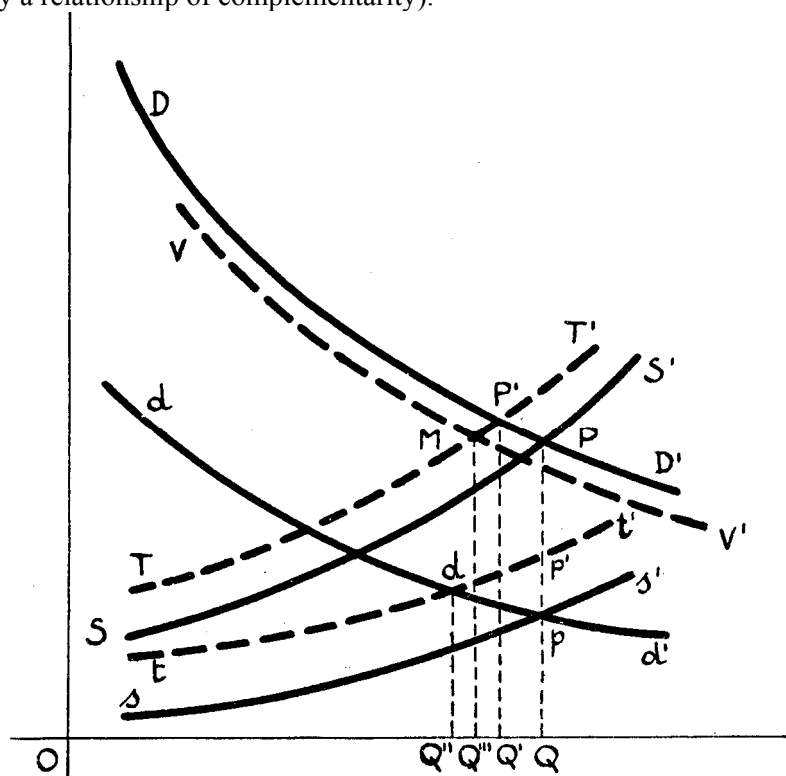
However, this fact, in Marshall's vision of the relationship to which we have made reference before, among the curves of demand and utility (presuming the marginal utility of money to be constant), leads to a lowering of the demand curve for *product B*; in this case, to identify the component action of the modified demand for *product B*, DD' is made to be reduced to position VV' in a first approximation. This latter curve then intersects TT' (curve of the group cost gross of the tax on *A*) at a point M to the left of P' , in other words, this would identify the quantity of equilibrium OQ'' , lower than that of OQ' previously identified, for the group.

II) If the curve DD' is not subject to any movement – as in the graphical exemplification carried out by Borgatta, who also had in mind the above mentioned relationship between the quantities and utility of complementary good – this means that the combinations of the two products *A* and *B*, expressed on the x-axis, are the same as those before the tax on *product A*, which has modified the trend of the cost from SS' to TT' . In the case illustrated, as the variation of the cost of the group appears different (lower) than that (amount of the tax) imaginable for the taxed *product A*, it can be deduced that there have been *adjustments* in the prices of *A* and *B* individually considered, also through events of cross shifting from *A* to *B* and corresponding incidences charged to the producer.

Generally speaking these hypothetical variations do not contrast with Borgatta's generic uniformity, quoted above, nor Edgeworth's specific one in the context of effects of the tax on complementary goods.

B) Shifting of the tax in the case of succedaneous goods.

This is also a very frequent case in practice and justifies the attention given to it in a theoretical context.

I) In specifying the sense in which shifting of a tax takes place in the hypothesis formulated here, account has been taken of the specific investigation carried out by Marco Fanno in the well-known monograph²⁰⁶.

For now let's remember some essential concepts so that we can understand the expression of the uniformities of financial character with regard in fact to the shifting of a tax which is charged to a product which has replacements or to the main product and its replacement.

Goods that can be replaced with each other are called *substitutes* or *replacements* in the establishment of a given effect of utility. There are very numerous actual examples that correspond to the definition, in the relationships between *direct products* of a different type (coffee and tea, beer and wine, cotton and wool, etc.), or between goods of the same type but of different quality (wine, oil, coffee of first, second and third quality, different railway classes, used and new goods, etc.); or between *instrumental goods* (wood vs. coal, mechanical vs. manual labour, electrical and hydraulic energy, etc.).

With respect to the satisfaction of given needs, if we consider the simplest hypothesis, the one of *two direct products*, they can replace each other totally or in part. The subject as consumer can acquire one or the other *exclusively* or both *simultaneously*, in the most diverse proportions. When the quantities of the two products alternatively or simultaneously used procure the same effect of usefulness, they are referred to in terms of *indifferent alternatives*.

These goods, in the various alternatives, *replace each other* in a determined *relationship*, which is called the *replacement or substitution relationship*. Two products tend to replace each other so that the respective *quantities* result in being economically equivalent to each other; that is to say, they are *inversely proportional to the degrees of utility*: therefore the relationship of replacement has been made equivalent to the *reciprocal relationship of degrees of utility*. These relationships can be identified through consumer *choices*. The indifferent choices of an individual with respect to two products which can replace each other in the most diverse proportions are infinite and they can be represented geometrically with *curves* or systems of curves of indifference.

²⁰⁶ *Contributo alla teoria economica dei beni succedanei* [Contribution to the economic theory of replacement goods], "Annali di Economia" [Economy Annals], 1926.

II) I have given precedence to these notions (even though they should be presumed to be recognised through introductory courses of political economy) to introduce the fiscal hypothesis and to consider the trend of the *variation of prices*.

First of all let's start from the *condition of equilibrium*, presuming partial equilibriums (of a group of goods only) and constant prices. In this case the consumer wanting to enjoy products together will choose, among all the possible combinations, that in which the quantities of goods *A* and *B* are combined so that in correspondence of them the *marginal relationship of replacement results is equal to the reciprocal relationship between prices*. Presuming a simultaneous and combined use of the two products, it is hypothetically excluded that the relationships between prices are excessively large or small and as such superior or inferior to all relationships of replacement. In this case consumption would focus on only one of the two products. This is against our assumptions.

Let's presume the intervention of a *tax* on the production of *A* of extent *I* for each metric unit produced, and that this is equivalent to an increase in the cost of production of *A*. The corresponding price (*a*) will increase. However, part of the demand of (*A*) will move towards *B* and the price (*b*) will also end up increasing. Therefore a *tax* charged on the production of *A* *determines an increase in the price of this product and of its replacement*. It is transferred to consumers of both products, that is to say also on the consumers of goods exempt from the tax.

Generally speaking, as the elasticity of demand is among the conditions (as has been seen) that influence the transferability of a tax, the existence of replacements *increases the elasticity of demand* of the main product. In this way it results superior to the elasticity of demand if there were no replacements for the taxed product. Therefore the tax on product (*A*) *is transferred to consumers of the same product to a lesser extent* than in the absence of replacements: however it is transferred to consumers of product *B*. If the production of this product (in a regime of competition) takes place in a context of *increasing costs*, the taxation of the main product (*A*) determines an *increase in the price of the replacement (B)* by extending production of *B* (because of its greater consumption). As this price variation limits the consumption of (*B*), Fanno was able to derive from the limitation of the premises the uniformity that: a tax on the production of a given product is fiscally productive only to the extent that it determines an increase in the price of its replacement and is the more productive the higher this increase is, all other things being equal.

This consideration is important in the explanation of events as it may happen that even though the legislator (on the basis of social policy premises) taxes *luxury goods*, in practice if they have (untaxed) replacements the demand will aim towards them, giving rise to an increase in price (which was intended to be avoided in the context of taxation), with damage to the less affluent classes that the legislator had not intended to inflict.

I give a geometrical demonstration of this process with the objective of clarifying in an approximate manner Fanno's argument, which the author expresses only in common language.

Let's report the respective quantities, *OE* (for *A*) and *OC* (for *B*) on the x-axis, presuming that the choice has been made so that the previously mentioned finished units of the main product *A* and of its replacement *B* replace each other in the same relationship of the corresponding marginal utilities. (In the figure the quantities are moved for the purpose of facilitating the reading of the graph.)

Let's trace the respective demand and cost curves, and the lines of the corresponding prices.

To clarify the concept graphically, two demand curves (*DD'* and *uu'*) have been traced, with different degrees of elasticity for the main product (*A*), presuming the near inexistence, *before*, of the succedaneous product, to then clarify the influence of the *possibility of replacing* with a certain quantity of the succedaneous product the main product whose price the tax *ii'* has caused to increase (from *PE* to *P'E'*). This possibility would increase the price to *E''P''*, less than *P'E'*, and would further reduce the quantity demanded of the main product (it would decrease from *OE'* to *OE''*), with a greater demand for succedaneous product (*B*) (which would then be raised from *dd'* to *vv'*, passing from demanded quantity *OC* to *OC'*) in part *replacing* demand for (*A*) (which has become more elastic as the dotted curve *uu'* indicates in the figure).

As product *B* (replacement) is produced in a system with increasing costs, as per curve *ss'*, the greater quantities required in replacement of the main product (*A*) will have a higher price which, according to Fanno's demonstration, would cause damage to the consumers of this product in

consequence of the fact that the tribute ii' has affected the main product (A), causing part of the demand for (A) to move towards product (B).

To avoid part of the demand for the (main) taxed product (A) being diverted, through the described process of substitution, to product B , the replacement, it is necessary to also tax product B with a tax (which as an example in the figure appears to be equal to tt'). In this case the quantity of the product that replaces the main product becomes lower than CC' , hypothesised in the absence of taxation of the replacement and which, in fact, as a result is equal to CC'' . If this is presumed, it is also presumable that the quantity of the main product is not reduced from OE to OE'' but to an intermediate quantity between the two. In other words, as Fanno stated, when not only the main product but also its replacement are taxed, the redistribution of the demand is lower and the revenue for the tax office is greater.



Figura 52.

Generally, to avoid demand switching towards replacements, it is necessary that these too are *simultaneously affected by the tax*. It depends on the relative extent of the two taxes as to whether the transfer in demand takes place from one product to another and in which proportions. *There is a relative measure of the two taxes [on product (A) and on its replacement (B)] such that, in correspondence with it, the distribution of demands of the two products remains unchanged.*

In any case, when there is a transfer of demand from consumption of product (A) towards consumption of product (B), *if this is also affected by tax the transfer of demand from (A) to (B) is attenuated.*

It is therefore possible to conclude like Fanno that, all other things being equal, a tax that simultaneously affects *all* products which can replace each other *avoids in total or in part the redistribution of income between the taxed and non taxed consumptions* that occurs, in fact, in the hypothesis that only one of them is taxed. Fiscal *revenue* is also *greater* in the case where both goods (in the hypothesis of two) are taxed than in the case that only one of them is taxed according to the law with a rate equal to the sum of those which could virtually affect both goods.

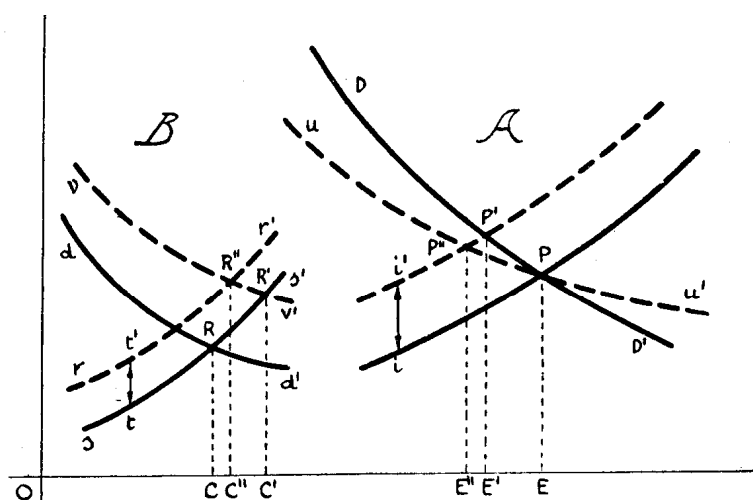
These repercussions, derived in the hypothesis of partial equilibriums and not considering the general equilibrium of the consumer, can be presumed to be the standard way to perform in the limits of hypotheses that disregard the numerous and complex circumstances of the real market. Hypothetically until now we have argued on the basis of the law of demand, such as it has been presumed to be up to now. We will see how Fanno's uniformities are modified assuming a different mode of considering the *demand of goods* in paragraph VII of Chapter XI.

XI.

COINCIDENCE OF PERCUSSION AND INCIDENCE: THE AMORTIZATION OF THE TAX

Another economic effect of the imposition is *amortization*. This can only occur when a new tax, or the increase of an existing one, affects the income of a capital used in the *long term* (as in land, buildings, lifetime incomes, bonds, etc.). It is said for example that land tax, at the time of its introduction, tends to decrease the value of land to the extent of the tribute capitalised at the current interest rate and therefore it affects the proprietors at the time of its introduction but not those who own it at a later date. This is so because these subjects, purchasing funds affected by the tax at a price reduced by the (capitalised) burden of the tax, use their capital at the current interest rate and even though they pay the tax they are not affected by its burden. The tax is amortised in the value of the fund reducing its value by the capitalised tax at the current rate, and the economic process through which this takes place is in fact the process of amortization. *Generally speaking this consists of a decrease in the value of the capital* (of long-term assets whose income it is the intention to charge) *equal to the capitalisations of the tax at the current interest rate*, for various types of investments. This effect is potential or virtual if it does not give rise to the sale of the asset at the time in which the tax is introduced.

Let's presume that a fund has the value of 100,000 units and that it generates a normal income of 5,000 units: if an income tax of 20% is introduced, the income will be reduced by 1,000 to 4,000 units. Presuming that the current interest rate on the market is 5%, by capitalising the new income we obtain 80,000 units, the new value of the fund, corresponding to the older value, after the deduction of the capitalised tax; this is the value that will be obtained from the sale of the fund. This decrease in the capital value represents the *amortization* of the tax. On the other hand the next proprietor, purchasing the fund at a price of 80,000 units and deriving from it a gross income of 5,000 units, which will become 4,000 units when it is net of the tax of 1,000 units, will derive the current interest rate of 5% from his capital and will pay the tax without bearing its burden from an economic point of view. Therefore the proprietor acquiring the land becomes the taxpayer *according to the law*, but the *actual* taxpayer is the one who in practice sees the value of the its land reduced by the effect of the tax (the seller).

At the point in which the tax is introduced (before the sale of the asset whose income is being taxed) it can be said that the *impact* and the *incidence of the tax virtually coincide*.

The current theory considers the phenomenon in the relationship between seller and buyer. The error is in failing to perceive that the consolidation or amortization between buyer and seller is bilateral. Each of the contracting parties avoids the tax charged on the asset he is buying, or that he receives in exchange of the asset he sells (De Viti De Marco).

Let's take the typical case of an *exchange between land and industrial securities*. The buyer of the land elides the land tax: however, the buyer of industrial securities also avoids the moveable goods tax. In short we always exchange or sell or purchase *net* incomes.

From this derives the fact that, after the exchange, *according to the law*, each of the contracting parties will pay the tax that is charged to the asset bought: *in fact*, however, he will continue to pay the tax that is charged to the asset *sold*. That is to say, each party brings with them, in practice, the tax that they used to pay. For example, if we exchange land that gives an income of 1,100 and pays 100 in tax, against a house that gives an income of 12,000 and pays 200 of tax, at the rate of 5% the total value – without the tax – would be 22,000 and 24,000 respectively: however the exchange occurs on the basis of equality of net incomes. That is to say, the land owner obtains 20,000 and leaves in the hands of the owner of the house 2,000, which corresponds to the capital value of a 100 tax: and the owner of the house obtains 20,000 by leaving in the hands of the land owner 4,000, which correspond to the capital value of a 200 tax. Therefore, after the exchange, the land owner will pay a tax of 200 on the purchased house, but he has also retained 2,000 more in terms of the purchase price; therefore, it is as if he continued to pay 100 as before. Similarly the seller of the house will pay 100 instead of 200 for the land bought, but it is also true that he has had to renounce a capital of 2,000 in the calculation of the values exchanged.

If we pass from the case of the exchange to the case of *buying and selling*, where the land is exchanged for money, as this is not charged with a tax, this would appear to be a *unilateral* consolidation as money is not charged with a tax. However, it only *appears* to be so, because the seller of the land, considering the “economic horizon” in his role of investor, discounts in the price the

average tax he will have to pay on the income from *any* investment for which the earnings from the sale are destined.

The definition of amortization also applies in this case of devaluation of the money, which may not represent a durable asset, in real terms or in terms of purchasing power. However money, as a means of preserving values over time, *represents* (in addition to consumer goods) the durable assets in which it is possible to invest and of which, therefore, the virtual or possible incomes are discounted.

De Viti concludes: *a)* each contracting party, after the sale, will continue to pay the tax that he was actually paying; *b)* therefore, the possible greater tax which had an impact on the first sellers will definitely be consolidated to their disadvantage. *c)* the tax office continues to collect the same tax as before, according to the law and in fact.

It is also possible to have amortization of the tax through *shifting*: for example, if a new tax is applied to salaries and wages and there is the possibility for wage earners to transfer the tax to the entrepreneur, the capital of the enterprise will be automatically devalued.

After the amortization has taken place, of course, if there is a variation (*decrease*) in the market in the interest rate, the *amortization* tends to be cancelled out. Some authors, Einaudi among them (*Osservazioni critiche [Critical observations]*, quoted in Chapter VII, an essay that I consider the greatest scientific contribution of the illustrious author), expressed the hypothesis that the revenue from the tax could be used in public services relatively more advantageously than the sum of utility that would have been achieved if the income corresponding to the tax had been retained in private hands. An increase in internal and international security, a more efficient administration of justice, etc., may *reduce the risk* of investment and therefore the *rate* of interest.

This is a theoretical case, which is furthermore far from devoid of historical examples, that demonstrates how the effect of amortization could be *attenuated* by further consequences of the financial phenomenon at interest rate level. It is understood that this may vary and it also varies for economic and political reasons that have no links with the financial phenomenon.

Defining the economic process that takes the name of amortization of the tax implicitly defines the case for a *special* tax, that is to say one that does not tax all categories of incomes in the same way.

However, even if the case had been made for a *general* and *uniform* tax, as not all incomes are derived by a durable or equally durable fund, the effect considered here would take place only with regard to incomes deriving from funds that represent durable assets. Furthermore, given that the same rate of capitalisation of income is not applied to all funds (and in the same location of the same national market), the effect of the tax, even if it is presumed to be general and uniform, *is not* that of modifying the *capital value* of durable assets able to provide an income.

Let's now presume that it is a tax proportional to the *capital value* (ad valorem) of assets at the time they are sold. Normally the legislator believes both the seller and the buyer *de jure* are obliged to correspond a tribute. Sometimes he indicates the person of the seller or that of the buyer. In some cases (for example, the Italian surplus value tax on property introduced in 1940) he does not indicate the passive subject. [Contrary to the views expressed at the time by some financial experts, I stated that it was indifferent, from an economic point of view (not in terms of juridical repercussions), if the person of the passive subject was respectively the buyer or the seller.] Indeed, the first (and this applies as a general theory) intends to obtain a certain net rate of income from the asset he acquires. For this reason he takes into account the burden represented by the value tax (for example registry tax) and detracts all or part of this amount in fixing the capital value he pays to the seller.

In that case it is said that the buyer *transfers the tax onto the seller* and that a process of *regressive* shifting takes place when the law identifies the passive subject in the person of the buyer.

Because in a certain sense the process is *automatic* and reflects the *objective* genesis of the venal value of capital assets regardless, within certain limits, of the behaviour of the buyer, it could be said that it is a case of *objective incidence* deriving from the simple introduction or increase of a tax. This incidence can be considered: equivalent to an *objective impact*, generically referred to the category of assets identified by fiscal law as taxable object, regardless of the passive subject (seller or buyer) who can also (as it has in fact happened) not be formally indicated by the same law (the law implicitly assumes that the buyer and the seller are united in tax evasion).

Finally, it is necessary not to confuse the possible temporary or long-term *elision* of amortization due to the effect of *shifting* of new taxes with lack of amortization. It is a matter of *possible* compensation of effects that does not at all invalidate the theory of amortization as it is expressed in the current doctrine. The two phenomena (amortization and shifting) are parallel even if, in their effects, they neutralise each other completely or in part and for determined periods of time.

XII

SUPPRESSION OF THE TAX

It will be remembered that, in giving a rational account of the “instants” of the effects of taxes, we have also mentioned the *diffusion* of the imposition as one of the multiple forms of the reaction, in terms of economic behaviour, of subjects who see their income definitely reduced through an incidence charged to them.

The behaviour of subjects affected as producers of income and hedonist consumers has been considered as an effect of the incidence or mode of implementation of diffusion. When faced with deprivation of income due to various forms of hypothetical taxes, it is presumed that it is possible to have an intensification of efforts with the aim of reintegrating the purchasing power of individual budgets, with the return at least partially to consumption of private goods, whose limitation is presumed to be due to the coercive use of public services and in any case a definitive destination of a part of the individual income to the public sector of the economy.

The problem of the suppression of the tax has been mentioned by various authors, from Pantaleoni (who wrote about it in 1887 and, with different conclusions, in 1904) to Barone (1894 and 1912), who gave a rational setting, later examined in more depth and completed by L.Rossi. Many others were also involved, among which I indicate Einaudi, Borgatta, Fasiani and, among the foreigners, Pigou, Dalton, Black, Knight, Robbins and Frisch, with disagreement in terms of conclusions which leaves the field open to discussion. It is true that, by and large, this discordance is due to the diversity of the hypotheses at the basis of the arguments on the part of the various authors, if not sometime the defective coherence of the development of the same arguments with the premises and with the nature of the logical instruments used in the respective analyses. This is the case, for example, with G.Déhove (*Impôt, Economie et Politique [Tax, economy and policy]*, I, *Pression fiscale et équilibre économique [Fiscal burden and economic equilibrium]*, 1947, Paris), who mistakenly thought he could invalidate the results expressed by L.Rossi, considered in this paragraph, as will be specified later.

I must also observe that generally speaking the problem of the suppression of the tax has found opportunities for study in the context of analyses of work supply, as indicated in fact by the essays of many of the authors mentioned above.

For now I will recall that Pantaleoni, examining the effects of fiscal burden, set the problem of the suppression of the tax using this specification. Having made the hypothesis of a completed shifting (or of a completed incidence) and of a closed market (and of a sum of taxes not greater than the sum of net incomes), he analysed the effects of the fiscal burden with regard to an individual who is in conditions of equilibrium as a worker.

By definition, this individual continues with his hard work to the point in which the marginal cost (or final degree of cost or the disutility of this work) is equal to the marginal utility (or the final degree of utility) of income, of the product achieved with work.

In graph no. 53, disregarding the intervention of the fiscal event, the point of equilibrium is given by the point in which the curves *AB* and *CD*, respectively representative of the utility and of the efforts (or costs) intersect each other, keeping in mind that the marginal utility is represented on the y-axis and that the corresponding portion of income (or goods or products) is indicated on the x-axis.

A) Hypothesis of fixed tax.

Having made this premise, Pantaleoni formulated the hypothesis that the condition of equilibrium (which maximises the difference between total utility obtainable from income or product or painfulness or total cost of achievement of income or product) is disturbed by the tax which is considered indifferently as an increase in marginal cost or as a decrease in marginal utility. He first formulated the hypothesis of a constant increase (capitation tax, such as, for example, a tax on bachelors for the aspect that is related to age classes and that disregards the extent of the overall income of bachelors). In such a case the effect of the tax will be to determine a new position of equilibrium in which the marginal utility of enjoyable (that is to say not absorbed by the tax) income (or product) will be equivalent to the marginal cost of the total product.

As the same Pantaleoni, who wrote this in 1887, later referred to the demonstration of his theory by Barone in 1894, I refer to what this author expressed for the demonstration of the case indicated above.



Figura 53.

In the graphical representation (Fig. 53), we presume the fixed tax (capitation) to be the amount t equal to RR' . It is a matter of understanding whether the taxpayer-worker will be persuaded to intensify his own efforts, and up to what point, to reduce private consumption as little as possible. It is clear that, after the reduction of his income due to the tax, the ordinate $R'V$ which corresponds to R' is higher than RI which measures the marginal cost of income OR . This means that the worker, generally speaking, will be persuaded to produce an income greater than OR . For now, to determine the problem, it is necessary to trace the utility curve relative to the income net of the tax t ; that is to say, a curve (Barone) whose abscissae are higher by the amount $t = RR' = MI'$ than those of AB corresponding to equal ordinates. The new curve with this characteristic will be $A'B'$ whose abscissae are higher than those of AB by $MI' = RR'$.

Having said this, if the individual wanted to obtain an income net of the tax equal to that of OR , he would have to increase his efforts to obtain OR'' , for which the marginal cost $s'R''$, however, is higher than the marginal utility (sR''). The point of equilibrium, on the other hand, will be determined by the intersection of the new marginal utility curve with the costs or effort curve. It will be precisely I' , to which corresponds the income gross of tax OP and the net or enjoyable income OP' . It is clear that at this point the marginal utility of the enjoyable portion OP' and the marginal cost of the entire quantity produced OP will be equal. It will therefore be: $MP' = I'P$. The suppression, in the hypotheses considered, will be *partial*.

B) Hypotheses of tax proportional to income

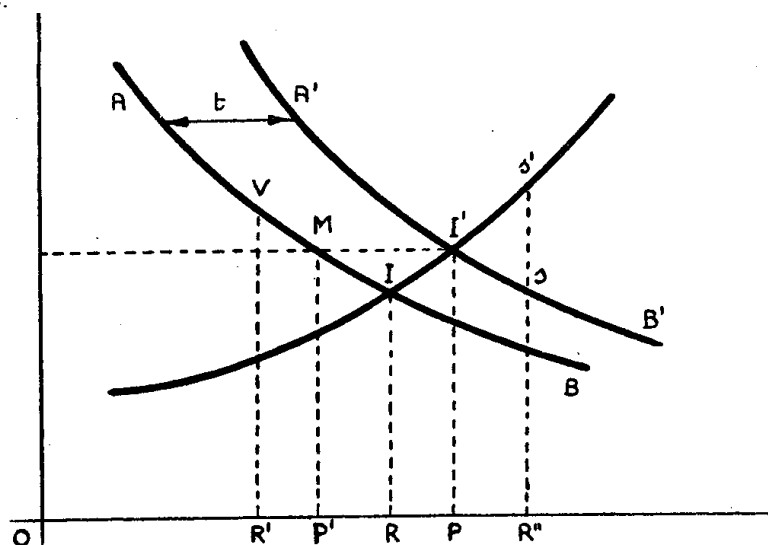
Going back to Pantaleoni, for the most frequent case in which the *tax is proportional to income* (or to the product), he states that “the enjoyable portion of product (or income) is not as in the first case the entire product (or income) less a constant, but the entire product less a constant fraction of the overall unit”. In this hypothesis too “there will be a *position of equilibrium when the marginal disutility of labour will be equal (as cost) to the marginal utility of the enjoyable product reduced in the same proportion, in other words – as Barone says – reduced to the net value*”. This appears clear, he adds, considering that it is still a matter of maximising or preserving the maximum difference between total utility and total cost and that the total utility is given by the utility of the product less its fraction absorbed by the tax.

Instead of using the demonstration given by Barone through a direct geometrical illustration, as he wrote, I will present the clearer one by L. Rossi (in the essay “*Di un caso particolare di Abwälzung*” [About a particular case of *Abwälzung*], “Giornale degli Economisti” [Economist Journal], October 1929). [Indeed, while Barone did not think it necessary to show the *entire transformed curve*, the author we are considering here did trace this entire curve, making the determination of the points of equilibrium in the various hypotheses more apparent].

To clarify what precedes, let's keep in mind that the elements that influence the issue, in the hypothesis of a tax proportional to income (Pantaleoni considered the product) are:



figura 54.

a) the decrease of utility of the portions of income that will be obtained after the tax has reduced them in a proportional manner; b) the increase in the marginal utility of the unit of available or enjoyable income after the entire produced income has been reduced by the tax to the net value; c) in relation to a) and b) the elasticity of the utility curve in each point of it, and in particular in the intersection point with the cost curve; d) the trend of the costs or effort curve; e) the extent of the tax.

In light of considerations *a) and b)*, there will be a transformation of the primitive marginal utility curve, presumed to be decreasing with trend UU' , in uu' , according to the figure in the graphical demonstration (Fig. 54).

To be aware of the indicated transformation, keep in mind that if 10, 9, 8, 7, 6 and 5 are empirical indices of the marginal utility of incomes of 100, 200, 300, 400, 500 and 600 units respectively obtained in 1, 2, 3, 4, 5 and 6 hours of work, the progressive difference between the indices of utility is *one*. On the other hand, if we proceed with the collection of a tax of 20%, this will reduce to 80 the net value in the case of the first hour of work and to 8 the index of total and marginal utility. For 100 the index of utility was 10: there is therefore a reduction of 2 which is reflected in the

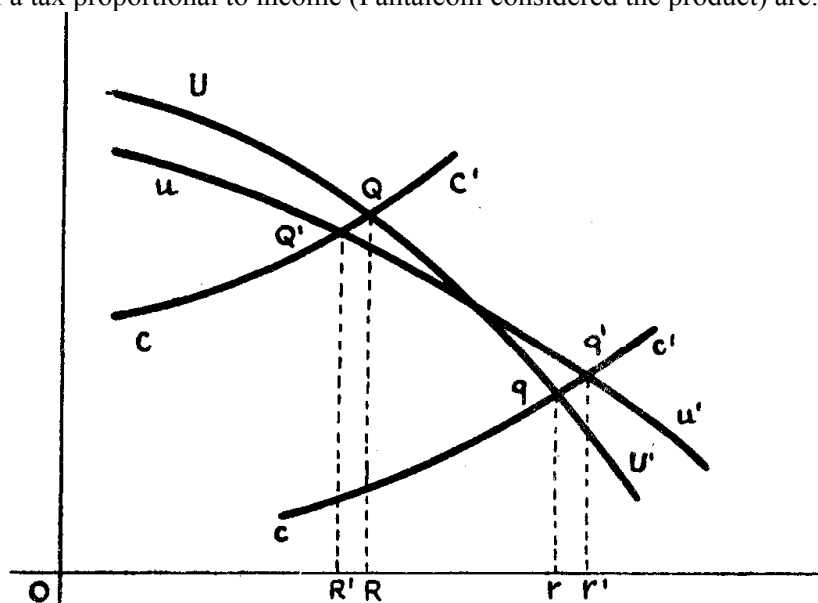
level of the curve at that point. However, when we consider the income of 200, reduced to 160 by the tax, there will be a total utility equal to 10 (for the first 100 units) and of 6.50 (for the 60 units multiplied by the index 9); 15.40 in total. Now, deducting 8 from 15.40 we obtain, in constructing the transformed curve, 7.40 for the marginal utility and not 7, that is to say the difference is less than one unit. In consequence, in passing to the index 9 for 200 (before the tax) to 7.40 for 160 (after the tax), the utility index has been reduced by 1.6 instead of 2. Continuing with this argument, we find that for 300 units of income in the third hour, having decreasing utility of 8, the total utility after the deduction of 60 for the tax becomes 10 for the first 100 units, 9 for 200 and 8 multiplied by 40, that is to say the net remainder: $19 + 3.2$ in total, that is to say 22.20, and deducting 15.40 (for the previous amount) from this we calculate the utility of the net salary of the last hour now as an amount of 6.80. In this case again, if we take this 6.80 away from 7.40 we obtain 0.60, which is less than one unit.

The utility index for 300 units (salary for the third hour) was 8 before the tax. After the tax, as has been seen, it has become 6.80 in the margin. The difference between 8 and 6.80 becomes 1.20 (less than 2 and than 1.6, that is to say, of the previous ones).

Continuing with the calculation for the subsequent portions of salary we find that the *difference between indices diminishes more and more*, to the point of giving rise to an *increase* in the indices that represents the marginal utility of the portions of income *after the tax*, which become the minuends with respect to the indices postulated before the application of the tax (which become the subtrahends).

Reporting the respective values on the Cartesian axes it can be seen, in fact, that the curve for the marginal utility of income net of the tax (*transformed*), after a long segment which is lower than the original curve (before the tax), *meets* or intersects it in a *point*, after which it *becomes higher*. The inclination of the original curve and the corresponding decrease in the utility curve in relation to the amount of income, as well as the type and amount of taxation, will influence the point where the two curves intersect each other and the probability that this might happen.

Let's imagine that, reflecting the operation indicated above, this curve is transformed from UU' to uu' . If we presume that the mode of growth of effort is represented by CC' , it is clear that, given the transformation of the utility curve, the worker does not have an interest in moving to the right of R' because every effort would not be further rewarded by an increase in utility (presumed to be decreasing after Q'). On the other hand, if we formulate the hypothesis of a trend in the effort curve represented by cc' and we presume that the point of equilibrium (between cost and marginal utility) is at q (before the tax), the transformation of the curve of marginal utility, as results from the figure, allows the worker to increase efforts to the point of reaching equilibrium point q' (after the tax) and to achieve income or' greater than or . There is the possibility to suppress in part the hypothetical tax that reduces income or .

Generally speaking there are segments of the curve of marginal utility of income that suggest that the process of suppression of the tax is *certain*, at least within certain limits. I refer to: *a) minimal incomes*, for which there are evaluations so intense of their utility with respect to vital or primary needs that the trend of the curve shows a rapid elevation. *b)* It can be similarly said that the suppression takes place with great probability and to a great extent when the curve, presumed essentially decreasing, experiences *interruptions* in this trend, rising for a segment because of the sudden appearance of intense needs that are *unforeseen* (at the time the hedonistic calculation was set, which is presumed to be characterised by a certain type of decrease of the utility in the margin).

Generally speaking, therefore, the suppression process depends on: 1) the *elasticity* of the utility of income curve, as it appears in the figure, expressed by the inclination of the curve of the same marginal utility, and measured at each point of the "transformed" curve by the relationship between a percentage increase on the abscissa and a percentage increase on the ordinate; 2) the mode of growth of the curve that expresses the painfulness or cost of labour; 3) on the amount of the tax proportional to income, collected by the State.

CHAPTER XI

OTHER PROBLEMS RELATING TO THE SHIFTING OF THE ECONOMIC AND HEDONISTIC COMPARATIVE EFFECTS OF TRIBUTES

I.

FISCAL DUTIES

This category of tributes, which can in fact be equated to that of taxes on consumption in terms of its shifting processes, in other words, because of the effects it gives rise to, needs to be taken into consideration from a theoretical point of view with regard to its actual distribution. They are included in public finance when the circumstances reported below occur.

The institution of *customs duty* has given rise to in-depth studies of pure or general economy theory. This is due to the fact that excise has a *fiscal purpose* or function, and a *protective* function, in respect to *national* productive facts. Therefore, political economy and, in particular, economic policy have studied custom duties from the point of view of the effects they have on international commerce and the economy of the respective internal markets.

From the point of view of public finance, only customs duties for the *import, export and transit* of goods, with *fiscal purpose* or *effect*, are relevant to public finance.

The fiscal purpose and effect coincide, so giving rise to fiscal duty:

a) in the case where the customs duty (for example for import, which is by far the most important category) affects goods *not* produced within the State;

b) when the customs duty is collected on foreign goods, to *exactly the same* extent as taxes on the production or exchange of the same national goods in the internal market. (For example, there is a manufacturing tax on the production of sugar when it is produced in Italy: to be *fiscal* in nature, ~~excise~~ duty on imported sugar should be the same. If, in addition to this, there is an *additional customs duty*, this has a protective purpose and effect.)

If a part of the customs duty has an impact on the foreign exporter, the *internal tax* on consumption must be *less* than the customs duty (the reason for this is to safeguard its protective effect) that is to say, so that the fiscal duty charged to the product object of consumption is *the same* both in terms of external customs duty and in terms of indirect internal tax on that item of expenditure, without *in itself* influencing the international production or determining the preference of consumers for foreign or for national goods.



Figura 55.

c) Furthermore, the duty has a *fiscal effect* when it is *not sufficiently protective*. A duty is *economic* or *protective* when its extent is equal to the *difference* between the *cost* of production for the *privileged producer abroad* and the *cost* of production for the *marginal internal producer*.

Let's presume that *oa* represents the unit expenditure for the product fabricated by enterprises with lower costs (privileged) *abroad* and *ob* represents the same expenditure for the *marginal national producer*; for simplification, the *protective duty* will be equal to *ab*, as it does not take into

account the cost of transport. It will take into account the cost of production for the marginal enterprise, placed at point c of the collective curve ac in terms of the *costs* of national enterprises, arranged according to a classification or “hierarchy” from the point of view of the respective minimum costs level. In that case the price will be equal to $cd = ob$.

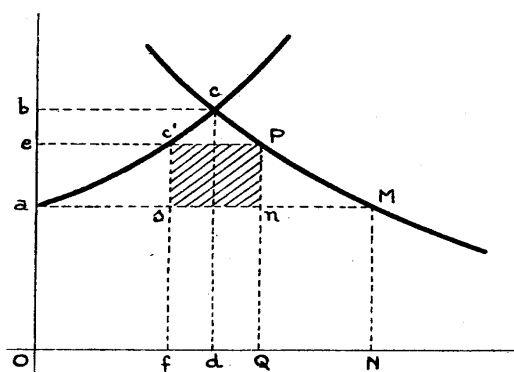
If we make the hypothesis of a reduction in the duty from ab to ae , the price would be reduced to $PQ = c'f = eo$. The marginal enterprise and generally those placed in the stretch of curve with costs $c'c$ will be eliminated from the market. As the demand curve at the *new price* $PQ = eo$, which it determines, allows the consumption of a quantity $> od$, and the national enterprises, for the time being, can offer the quantity $o-f$, foreign goods will replace national goods when these cannot meet demand. The duty that affects the quantity fQ of foreign goods has a *fiscal effect* because it is not sufficiently protective. That is to say, it is not sufficient to replace “pro rata” the import of identical or similar goods with internal production.

The shaded rectangular area $sc'Pn$ represents the *fiscal revenue* obtained by the State, as a product of the quantity fQ coming from abroad to the national market, multiplied by the duty ae that affects it as a unit.

Of course, even when the duty is exactly protective in a theoretical sense, it is possible that a policy of *dumping* (or sale at below the foreign cost of production) may lead to goods entering a protected market, giving rise to a revenue for the State and leading therefore to a *fiscal effect* of the protective duty.

The illustration of the case where an insufficiently protective duty leads to fiscal effects could give the idea of a total, systematic impact of it on national consumers (in other words, of the country I, that is to say, importer of a part of goods from abroad). Instead the duty can have an impact on country E, the exporter country, even if it has *fiscal effects*.

The elasticity of demand and supply, respectively in countries I and E, and the reactions that take place in terms of the production costs of the exporting country, are among the main circumstances that have an influence on the impact of the fiscal duty in the two countries.

I) To verify this, keeping in mind the influence of the elasticity of demand in particular, let's take the first *case* in object, where the *goods* are *produced both in the importing* and in the *exporting countries*. Let's presume that, before opening the market and the start of international commercial relationships, country I and country E manage to satisfy, within given limits, internal demand. Hypothetically, therefore, the following demand- supply curve will apply in a closed market situation. (I warn the reader that, according to traditional representation, the two curves of country I are symmetrically reversed.) For simplification, I will presume transport costs to be nil (Fig. 56).

The quantity OQ will be produced and sold at price PQ in country E. In country I, the quantity OQ' will be produced and sold at price $P'Q'$.

Let's presume now that markets are opened. The equilibrium will be established on the line $ABLE$, whose sections, intercepted by the curves (which are the quantities imported and exported), are equal: $AB = LE$.

Because of the opening of markets, in country E the *price* increases and consumption is reduced, but in exchange production increases and is destined to *export*. In country I the price is reduced and the quantity of goods consumed (following *import*) exceeds preceding levels, that is to say, in a closed market regime.

The opening of the markets brings a benefit to both countries, because in country E what is lost to the consumers is gained in terms of surplus for producers; and in country I, what is lost to the producers is gained in terms of surplus for consumers. The areas LEP and ABP' indicate the respective advantage.

If country I were to introduce a duty of extent d' , this would be prohibitive to exchanges. However, if we make the hypothesis of a duty lower than this amount, of extent gf , this would limit part of the previous advantage. The treasury of the importer country would obtain a revenue represented by the rectangle $mnrs$. However, not all duties have an impact on consumers of country I (importer); a portion of them, as can be seen from the diagram, is charged to the exporting country, and impacts on exports of country E exactly in terms of the amount zf . The partial incidence on consumers of country I depends on the *elasticity of demand*. If this had the trend of the dotted curve

starting from A , a part less than gz (i.e. $g'z'$) would impact on consumers of country I and a greater portion would impact on exporters of country E. Clearly $HK = H'K'$, as $mn = m'n'$, to express the equality of the quantities respectively imported and exported by the two countries.



Figura 56.

II) Let's now consider the typical case of a *fiscal import duty by definition* that does not need to be proven: that is to say, that is charged to goods *not* produced in the *importing* country I (Fig. 57).

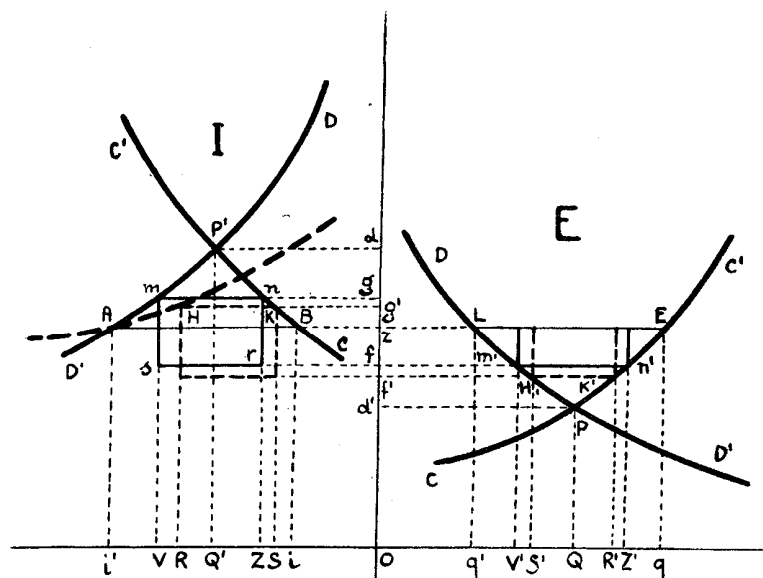

Figura 57.

In this case, in an open market context, the equilibrium is still established along the line ABL , which intercepts the demand- supply curves of the exporting country and the demand curve of the importing country. The quantity exported BL is equal to Am . If a duty of df amount is introduced, it will in part have an impact, through dm , on consumers of country I and in part on exporters of country E (in other words through mf), as is shown in the diagram. As there is no internal supply in country I, the duty line intercepts *only* the demand curve in this market, giving rise to an *impact* that is generally *greater* than in the previous case. This can be seen from the dotted evidence, which reveals an incidence equal to the extent of duty $md' < md$, keeping in mind that the portion vd' of quantity td'

demanded in country I (importer country) is offered or produced in country I. In fact, if the supply curve is raised, rotating it until it coincides with the ordinate axis, the area $tzkv$ coincides in degrees with the areas $rsfd$ for which, as has been presumed, the impact is greater, as the internal supply mC is annulled.

III) If the *duty* is introduced by the *exporting country E*, for example, on goods on which it has a *monopoly* and that are not produced in country I (for example, coffee), the impact tends to affect mainly consumers in country I, and more so when the *demand curve* is *less elastic*.

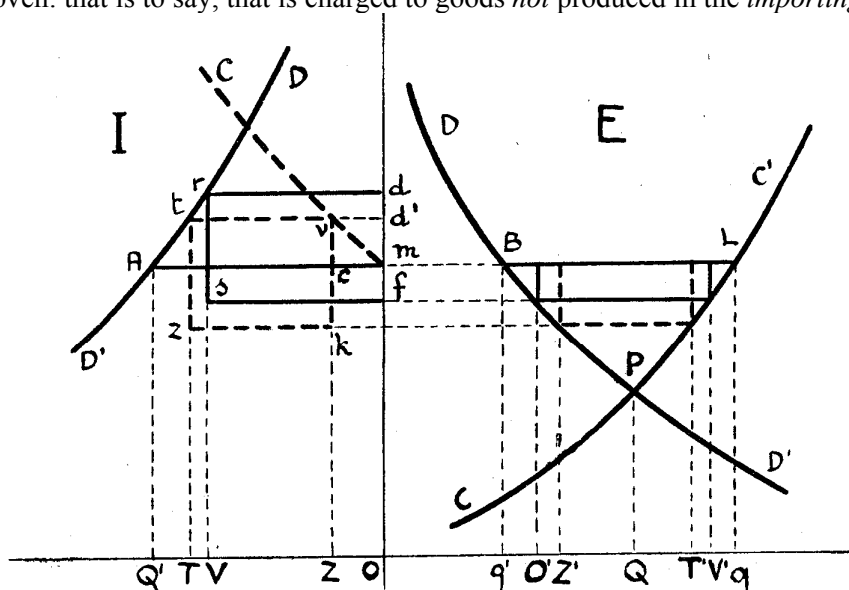

Figura 58.

The case, quite clear after what precedes, is illustrated by Fig. 58, from which it appears that the *export duty* df has an impact of dc on consumers of country I and an impact of cf on producers of country E.

II.

SPECIAL EFFECTS OF THE TAX ON ALL EXCHANGES

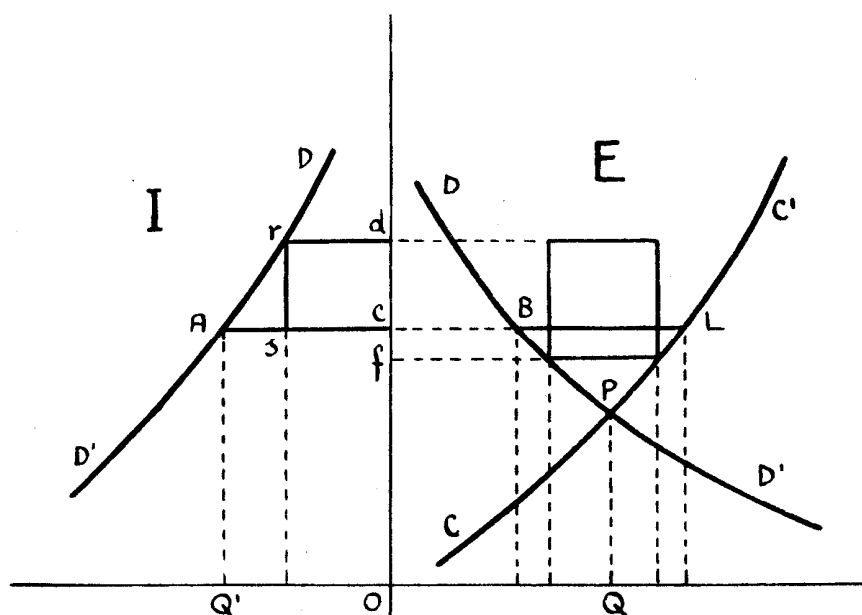
I) Another tribute that gives rise to particular effects is the *tax*, incorrectly denominated as a “tax”, on commercial exchanges and which has been transformed into the tax on “income”. Among the various economic effects²⁰⁷ I will consider one that has given and is still giving rise, abroad and in Italy, to important legislative reforms. (For the relative shifting I refer the reader to the chapter on economic effects.)

I am referring to the *accumulation* of the tax, if applied on *all* consecutive exchanges of a given product, through a certain rate, which I define here as *standard*. As the legislator intends, through progressive *shifting* from producers and traders towards consumers, to charge the latter, we consider the *economic absurdity that derives from this* in some hypotheses, as a consequence of which the tax may affect producers and traders without achieving the fiscal objectives for which it has been applied.

²⁰⁷ For which I refer the reader to E D'ALBERGO: 1) *La natura e il fondamento delle imposte sugli scambi* [The nature and foundation of levies on exchanges]; 2) *Di alcuni effetti economici delle imposte sugli scambi* [About some of the economic effects of levies on exchanges]; 3) *La condensazione dell'aliquota delle imposte sugli scambi* [The condensation of the rate of levies on exchanges]: “Giornale degli Economisti” [Economist Journal], October–December 1931 and April 1935.

To quote one of the aspects of the tax more susceptible to criticism, let's admit, *per absurdum*, that *each* fraction of the tax, paid on the occasion of an exchange between producers and intermediaries, will definitely be ultimately charged to the consumer. Let's now make the hypothesis, indeed a real one, of a given consumer item being produced *simultaneously*, in the same industrial sector, by individual enterprises organised in a *vertical* sense and by enterprises who concentrate their production activity, respectively, on a single *phase* of production (organised in a *horizontal* sense).

In the first case there are two exchanges of prime materials and finished goods between producers and intermediaries before the item reaches the consumer: in the second case, there are four intermediate exchanges. It is clear that in the second case there will be a sum of taxes charged to the various exchanges which is, *per unit*, of the extent approximately double that of the first case. If it is admitted that the costs in the two cases differ only in terms of the extent of the tax, which affects them because of the automatic shifting presumed to have taken place in the various exchanges and that the last seller, in both cases, wants to achieve an "equal" (minimum) profit, there would be the case of goods of the same type and of the same quality being sold in the same market at a different price, because of the different effect of the fiscal burden. From the point of view of the premise of the legislator (who wants to achieve the principle of the shifting of consumption), this absurdity would indeed occur.

Furthermore, if it is a product whose supply cannot be increased by the enterprises who are in a more favourable position with respect to the tax (vertical organisation) or with respect to which an increase in price does not determine a decrease in demand, then the price will be fixed in the market, for the same quality, by the *cost* of the enterprises that (in a system of horizontal organisation) are in a *less favourable* situation with respect to the tax. In this case – still presuming complete shifting – consumption would bear the overall burden of the tax on exchanges. However, organisations organised in a vertical sense would achieve an "income" which is derived by the order of the tribute.

If it is a matter of goods (and indeed they are quite common) in respect of which there are such relationships between demand and price that the competition leads to fixing price at the lower level of cost (this hypothesis can be considered normal, in the case of dynamic conditions), the enterprises that produce and exchange goods in a system of horizontal organisation cannot transfer the greater part of the tax and therefore become affected by it: theoretically this is so because of the *difference* between the burden of the tax on a *greater number of exchanges* and that found in a system of concentrated production and with a lower number of exchanges (vertical organisation). The absolute premise from which the legislator starts (that of an automatic shifting) becomes absurd and the tax on exchanges acts in part and for an indeterminate time (and as long as there are no variations in the conditions of the market and in the production organisation) as a tribute on the *volume of business of producers* (industrialists, traders) so having an impact on profits²⁰⁸.

Similar considerations apply in those cases of different *commercial* organisations for the sale of the same type of product.

To solve such inconvenience, which creates *advantages* (incomes) for some (vertical organisation) and *disadvantages* for other enterprises (horizontal organisation) in the legislation of some countries, the process of *condensation* of the normal tax rate has been introduced.

Let's now examine the details of the reform that intends to placate this criticism and which therefore implements the *equality* of the *imposition* in the relationship between *lawful* taxpayers. [This condition in the context of taxation at *standard* rate is often in contrast with the economic premise that, for exchanged goods and products of the same quality, in the same identical conditions of time and place, and all other things being equal, there is *only one price in the market*. Indeed, the hypothesis that is explicitly or implicitly considered by the legislator in many countries, that of total continuous forward shifting of the tax for enterprises that clearly exchange the finished product, obtained through a series of relatively superior exchanges (horizontal organisation), may not happen at all.]

²⁰⁸ The decree of 14 September 1931, which modified the structure of levies for cotton products, had intended to solve the problems mentioned. Many other subsequent measures had the same objective.

For some goods or categories of goods it is possible to indicate that not *every individual* exchange is to be charged, but only *determined* exchanges that take place in a normal cycle and so as to charge, in the finished *product*, those elements that make it up and to *exonerate* the previous and subsequent exchanges. The rate will be determined, according to the *average* number of subsequent exchanges merged together, taking into account the sum of the various profits as prices of sale, so that the rate might result as far as possible in being uniform for individual categories of goods.

It is a matter of solving the problem: what should be the extent of the condensed rate (Q), applied *once only* to a given exchange, so that it can replace the “standard” rate which affects all exchanges, to result in an equal revenue for the State?

We indicate, concisely and by using symbols useful for convenience of presentation, the process of condensation of the rates of the tax on exchanges.

We know the prices p of the individual semi-finished products (1, 2, 3 ... n), respectively for quantities ($v_1, v_2, v_3 \dots v_n$) included in the finished product. In the consecutive phases of exchange (I, II, III, etc.) in the context of subsequent industrial transformations,

the first semi-finished product has the values expressed by:

$$p_1v_1^I, p_1v_1^{II}, p_1v_1^{III}$$

the second semi-finished product,

$$p_2v_2^I, p_2v_2^{II}, p_2v_2^{III}$$

and so on. The prices of the finished product, in the individual phases of (commercial) exchanges will be:

$$p_f^a, p_f^b, p_f^c, \dots p_f^m$$

If u is the uniform rate of the tax charged on all exchanges, the sums collected overall on each unit of finished product will amount to:

$$U = \frac{u}{100} (\Sigma p_1v_1 + \Sigma p_2v_2 + \Sigma p_3v_3 + \dots \Sigma p_nv_n + \Sigma p_f)$$

This amount of tax U can be obtained with a single collection, through the application of a tax rate Q (*condensed*), for example, from the last sale price (P). In fact, in percentages, it is

$$Q = \frac{U}{P} 100$$

To clarify the process by simplifying it, we replace the symbols with arithmetic values : product A undergoes the following steps:

<i>as a semi-finished product</i>	Price	Tax (2% base rate)
I) from producer to wholesaler	100	2
II) from wholesaler to finished product manufacturer	150	3
<i>as a finished product</i>		
a) from producer to wholesaler	400	8
b) from wholesaler to retailer	500	10
c) from the “retailer” to the consumer	800	16
Amount of tax (U)		39

which, referring to the price of the finished product ($P = 800$) purchased by the consumer as actual passive subject, gives a *condensed rate* of 4.875%.

Clearly the *condensed rate* ends up – as happens in practice – relatively *higher* than the *standard one* because it is synthetic, in other words, comprehensive of the rates that *would have been applied* to the individual exchanges considered separately in a regime of standard rate.

Some students observed that by limiting the process to I) and II), respectively, (semi-finished product), or to these first two exchanges *plus* the one *a*) of the finished product, or to all the preceding ones *plus* the one *b*) of the finished product, or finally all the previous exchanges *plus* the one *c*) of the finished product, it was not possible to obtain a *series* of condensed rates which was *continuously increasing*. Indeed, from 2% (standard) we pass to 3.33 at the second exchange, 3.25 at the third exchange, 4.60 at the fourth exchange, and to 4.87 at the fifth exchange. The continuity of the progressive trend is interrupted between the second and the third exchange. However, this is due to the fact that, in proceeding to the sum of taxes, *quantities* that are not *proportional* with the last price are referred to it, such as the *sums* of the *relative tax* to *previous amounts*, and proportional to those alone. What is of interest here, for the logic of the procedure, is that the *condensed rate* end up being *different* from the *standard one*; that is to say, it is generally higher.

Essentially, in the case of the tax on exchanges, it is a matter of placating the criticisms that the application of the standard rate gives rise to, from the point of view of taxation of consumption, to make the structure of the tax in question more similar, through the condensation of rates, to the more rational one of tributes that are juridically different but that pursue the same fiscal objective: (specific) manufacturing taxes, duties, monopolies, (proportional to value) consumption taxes in the strict sense of the word, whose rate is definitely determined “*a priori*”, in function of complex criteria (economic, social, fiscal and sometime juridical ones) that, because of doctrine tradition and administrative experience, guide the taxation of this basic manifestation of contributive capacity.

I refer the reader to the quoted essays for further analytical clarifications and for the study of other effects of this tribute.

The transformation of the tax on commercial exchanges in a tax on income, with a uniform rate (of 2%), corresponding to the one that is defined as “*standard*”, could have led to the fear that the Italian legislator in 1940 had neglected to alleviate the problems of this system that only the condensation of the rate can, as has been seen, rationally eliminate.

However, while pre-existing rates were formally abolished and those that were applied as a tax on exchanges were condensed, it was estimated that the rate might increase *threefold* for the purpose of levelling the different tributary burdens (in the distribution according to the law) with respect to those enterprises that, respectively, undertake a different number of exchanges or economic events subjects to tax. This derives also from the *existing* industrial and commercial organisation and not only from those cases to which the Finance Minister had made reference, “of possible concentration of enterprises *with the purpose* of elision of a part of the burden of the tax on income”.

It was impossible for the Italian legislator not to accept the conclusions of the theory on this point. However, I do not understand why the maximum increase was peremptorily fixed at a level three times that of the tax (however high), even if in practice there are a number of exchanges or incomes, at parity of finished products brought to the market, that require a greater condensed rate.

II) To those who, like me, have, in a political legislative context, advocated the extension of the single rate to already existing cases of vertical concentration in industry and commerce (in addition to the cases of possible formations of “*artificial business structures*” to which the Minister had made reference in the “*report*”), some have responded that the standard uniform rate is preferable for taxpayers according to the law, considered as purely individual subjects. It is intended to make reference to the greater *difficulty* represented by the *shifting* of the condensed rate, necessarily higher than the standard rate. Furthermore, there is a reference to the burden of the *anticipation* of the tax on the part of actual taxpayers, who ultimately should be the buyer-consumers of the goods charged.

Objections of this type are easily overcome. With regard to the variable degree of transferability of the 2% tax, in other words, of 4%, it is illogical to apply the argument that general theory has put forward in observing that, all other conditions being equal, the *extent* of the tax is a circumstance that first of all impacts on the phenomenon of shifting.

The error consists in comparing the two rates (the “*standard*” one and the “*condensed*” one) without commensuring them with the price of goods at the *diverse stages of exchange*. Indeed, if

account is taken of the *reaction of demand* for the purposes of shifting, it is *indifferent* for the consumer to consider the rate of 4% for a price of 300 for a finished product, so that a tax of 12 is applied to him; in other words, it is the same as applying the rate of 2% to the price of 300, and then adding a tax of another 6 units to be passed on to the seller of the finished product (let's presume 2% on 100, cost of the prime material, + 2% on 200, cost of the semi-finished product). As the sale price of the *finished* product is unique in the market, the seller of the product that must transfer the tax of 4% (that is 12 units) will have to overcome the same obstacle as the one who finds himself at the end of a series of exchanges and must add the amount of 2% (standard rate) to the sum that has been added to the price of the item for fiscal repercussion.

The *illusion* of having to bear a higher burden with a single rate of 4% fails when the rate of 2% leads to the same price for the finished product.

Nor is the objection relevant that relates to the cost of the *anticipation* of a higher tax for the taxpayer chosen as the single participant to the exchange to be charged: it is known that high sums are anticipated (with respect to the industrial price of goods) in the case of "manufacturing" tributes.

Already in 1931, while dealing with the economic effects of the tax on exchanges, I found myself set against supporters of the opinion that the same tax would lead to an *increase* in the price of taxed goods *to a greater extent than the amount of the tribute* for "additional burdens" deriving from the *interest* on the sum that precisely would be anticipated by the seller to be allocated to the State for fiscal purposes. In the particular case of the mode of application of the tax on exchanges, I argued that if the shifting takes place, as the collection takes place with a "charge" to the buyer, in theory and also in practice with great approximation to the theoretical case, the *moments* of percussion and of shifting *coincide* (in other words, those of the anticipation and of the reimbursement, from an accounting point of view).

In any case, an argument similar to the one I put forward with regard to the shifting of a necessarily higher single tax (*a*) because "condensed" with respect to the "standard" one (*b*) to demonstrate the *indifference* of the two hypotheses (*a-b*) for the consumer (presumed to be affected) can be put forward by drawing on "classic" and later practitioners.

Indeed, in theory, "additional burdens" deriving from the *anticipation* of the amount of the tax on the part of the *juridical* taxpayer chosen by the legislator (importer, manufacturer, wholesaler or retailer, etc.) are not justified in terms of the collection of an indirect tax on consumption. This is so because, between the moment (*m*) when a *juridical* taxpayer anticipates the tax and the moment (*m'*) when the buyer reimburses him by shifting, the latter has preserved the availability of the monetary amount corresponding to the tax. (I will add the hypothesis that both subjects, the seller and the buyer, have the same possibility and ability to earn interest from the sums at their disposal.)

In other words, for the time *between m* and *m'*, the buyer can draw, from the amount of income that is available to him and that he will use for the purchase of the taxed item, an *interest equal* to that which the buyer adds, at the same time, to the sum anticipated as being due to the State.

Therefore the buyer (consumer to be charged) is clearly *indifferent* as to whether he bears the burden of the tribute (*T*) at time *m*, or is charged by shifting of the sum $T + r$ (*r* being the interest) at time *m'*. Therefore the term "additional burden", which would be charged to the consumer in addition to the tax, does not make any sense.

III) A procedure that the positive exemplification abroad contemplates is that which limits the commensuration of the rate of the general tax on consumption (normally applied to the full value at the stages of exchange or at the time when the income of the sale of the goods is obtained) to the differences in value in the technical and spatial (commerce) transformations, that is to say, to "added value".

However, once some diversity of secondary psychological and economic or empirical effects are removed, *at a similar level of income*, it would appear that there is ultimately an equivalence between the system of taxation of the full value of goods and that of the taxation of the differential or "added" value.

Let's presume that a kilo of raw cotton transformed into yarn has the value (or the price) of 1,200 units, the woven product 1,800, and that bleaching or stamping bestows on the material a final value of 2,000.

Unlike what happens with the standard rate commensurate with the full values of all exchanges and unlike what is reported in the explicative example of the condensation of rates, even if virtually, the tax in the process that considers as a taxable base only the “added” value will not be charged to the *full* values of which we have given examples of but rather only the *differences* from the base value of 1,200. In the example given, these are 600 in the exchange relating to the woven material and then 200 for the stamped material in terms of added value, in comparison with the preceding transformation stage.

As we are arguing in terms of similar income, if we wanted to obtain, for example, 50 units of tax on the value of the finished product, we can alternatively proceed as follows: 1) with the taxation only once, of the finished product of value of 2,000 units, with a single rate of 2.50%; 2) or with repeated taxation: *a*) with 1%, for example on 1,200 units (12 units of revenue); *b*) with 1% on 1,800 units (18 units); *c*) with 1% on 2,000 units (20 units); 3) in other words, with taxation of 1% of the full base value of 1,200; then with 3% of 600 units of added value; finally with 10% of the 200 units of value added to reach the value of the finished product to be sold at 2,000. (This third case is presented according to a variation – which can be suggested for fiscal technical requirements – of the more general one, which see the taxation, with a *constant rate*, of the added values. In the specific case, there would be the application of a rate of 2.5% of the base full value of 1,200 and subsequently of the added values of 600 and 200.)

In cases 2) and 3) we have collected 50 units in total that, commensured in percentage terms with the finished value of 2,000 give, as in case *a*), an overall rate of 2.50%.

From an objective point of view, there is no great difference in the systems and no real progress, in terms of passing to the imposition of the added value.

III.

MANUFACTURING TAXES, FISCAL MONOPOLIES AND THEIR ALTERNATIVES

1) It has been said about *manufacturing taxes* that the theory of the effects of taxes (mainly shifting) that applies in the abstract case of the tax commensured with quantities produced applies to them.

However, when reference is made to the real manufacturing tax, some authors have stated that its forward shifting is so certain that it is not appropriate to use the term shifting but rather that of accounting *reimbursement*.

This was, for example, De Viti De Marco's view, which did not appear at its time (1931, in the essay on the tax on exchanges, quoted) to be acceptable with regard to analogous tributes. In the specific case of the manufacturing tax, in theory it had been demonstrated that a manufacturing tax per unit of product determines a new position of equilibrium in which the tax is charged in part to consumers and in part to entrepreneurs; some firms disappear: the profits of remaining ones are reduced. The part of the tax that affects consumers is greater or lesser according to the lesser or greater elasticity of demand and according to the inclination of the supply curve, that is to say, according to the distance from the status of constant costs towards which perfect and ideal competitions tends, and according to the possible hypotheses of imperfect competition or monopoly.

“Here, therefore, states Barone (p. 312 of *Principii [Principles]*), for example, as in the case of the manufacturing tax in which it was intended for the entrepreneur (producer) to be, so to speak, a simple anticipator and collector, the situation is made complicated because a part of the tax is *transferred to enterprises*”. With regard to this, I refer the reader to the theory developed in the case of the tax on quantities produced and to an article by U. Ricci on the effects of an “excise tax” or consumption tax applied to the quantity produced (in “*Studi economici e finanziari corporativi*” [Corporate economic and financial studies], July 1941).

2) Another observation that needs to be made with regard to the manufacturing tax relates to the *limitation of its application in the field*, from the point of view of the *cost of collection*.

This point of view will be here divided into two.

I) On the one hand, it is said that the manufacturing tax is expensive because it is applied to the producer who is, given the market organisation, normally *removed from the consumer*. As has been seen, the manufacturer advances the sum to the State and requires therefore interest on this advance, an interest that is charged to the consumer in addition to the tribute.

About the theoretical and practical objections previously presented (at point II of paragraph II) when faced with this observation, Barone expresses the doubt that, by resorting to another collection system, at parity of revenue, the State might eventually require a greater sacrifice. All forms of collection have a cost, he writes. For a given "revenue" (represented by the shaded surface) it is necessary to go up from m to n , $a-b$ being the unity cost of collection. In the case of the collection executed via the manufacturing tax, $a-b$ also includes the interest on the advance. However, another collection method could involve an even greater cost than $a-b$ [$abst$ being the total collection cost for the quantity oq' sold at price $nq' = ro$, and $nsbr$ the *net* revenue for the State] for each *unit* collected.



Figura 59.

It is essential to give preference to a method for which $a-b$ is minimal. It is a matter of comparing this element of the manufacturing tax with the collection cost for other tributes.

In the case of the manufacturing tax, it is necessary to take account, in fact, of the *monitoring* needed of the quantity produced by entrepreneurs, a quantity to which the tax is proportional.

To ensure that the cost of the monitoring and, therefore, that of the collection is relatively low, it is necessary that the taxed goods be produced by few, large establishments, in other words, *centralised*, so as to reduce to the minimum monitoring costs.

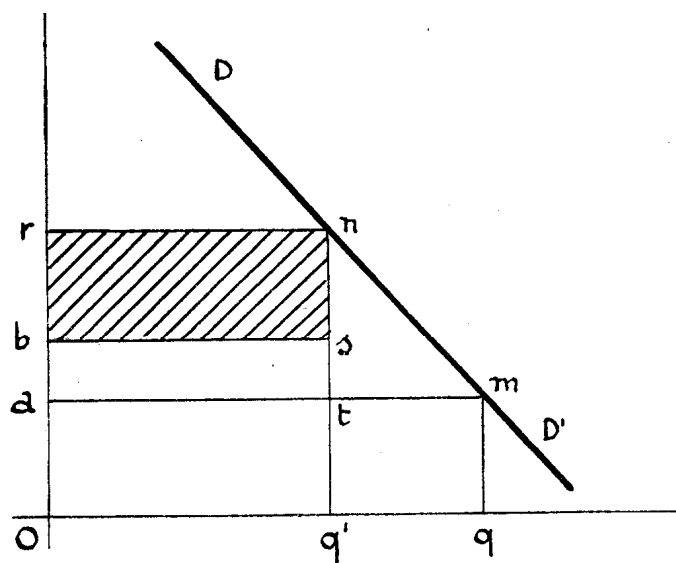
The State uses this tax to collect sums related to the quantities of units produced. Let's think of the case of an average tax normally collected per ton of sugar produced; in particular let's think of the internal manufacturing tax on spirits, on average around 32,000 units per anhydrous hectolitre²⁰⁹, and we can understand the incentive for *evasion*, that is to say, why it promotes *contraband*.

²⁰⁹ These levies are subject to frequent variations of rates for purposes that are not only fiscal but also relate to social policy.



Figura 60.

Mainly for this reason, it is probable that the State may not manage to obtain the *maximum* net revenue that could be obtained in the case in which it were not to avail itself of the production enterprises, even if centralised and easily monitored, but were to establish a *fiscal monopoly* of production. In other words, with the method of the manufacturing tax collected through the production enterprises, the price that the State sets in the market, when it intends to achieve the revenue represented by the area *bcnm*, will not be the *maximum* net revenue that could be achieved with the tax equal to *bc*, with the method of fiscal monopoly, for the monopolist (State). Essentially the price of maximum revenue, in the case of the manufacturing tax, will be *lower* than in the case of fiscal monopoly, which is an alternative to the manufacturing tax.

II) When the State wants to ensure the maximum net revenue, it resorts in fact to *monopoly*, reserving for itself the production or the sale of some consumption goods (for example, tobacco, salt, bananas, etc.) or the exercise of public lotteries.

Of course, there are few types of goods that lend themselves to State monopoly: they need to be industries that, because of their organisation, can achieve a *cost that is not too high* compared to that achievable in a competitive regime.

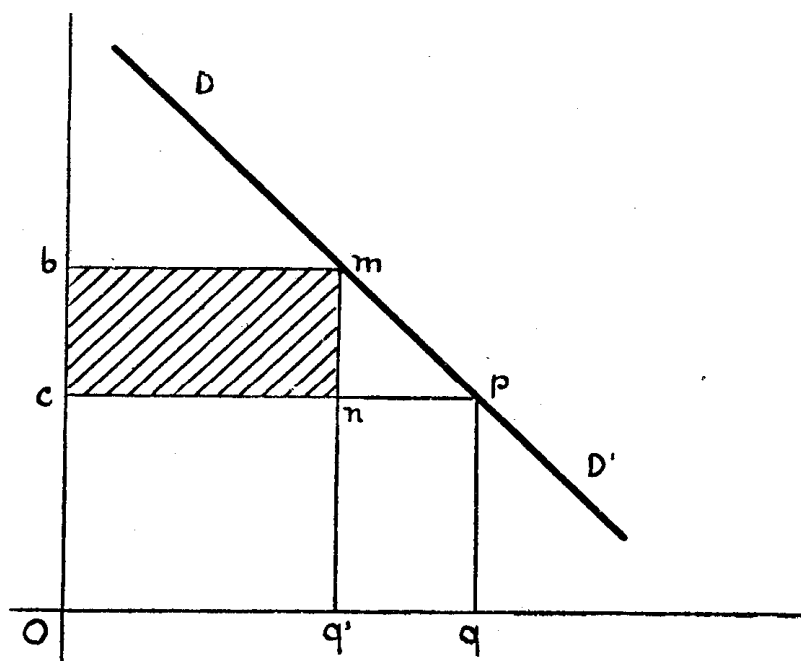
The so-called traditional point of view was presented in the previous chapter – in contrast to the more recent one that can lead to a different result because of the diversity of hypotheses on which the argument can be based. According to this traditional point of view, monopoly appears to be generally condemned as contrary to collective wellbeing, because the revenue achieved by the monopolist is less than the damage caused to consumers (in terms of, for example, *denied consumers surplus*), who are prevented from benefiting from the lower price they could pay, at similar levels of consumed goods, if the production were to take place in a competitive system.

Because in this case we are dealing with *fiscal monopolies*, that is to say, with the objective of achieving the maximum revenue for the State, in terms of taxes on such goods, it is a matter of rearranging the convenience calculation to the point of view of the State, and observing if this system (monopoly) meets one of the criteria of taxation: that is to say, the one of the *affordability of collection*.

In fact, it may happen that, abandoning the system of fiscal monopoly, the State gives rise to a higher collection cost than the one incurred in the case of monopoly to achieve the *same amount* of tax on consumption.

In Barone's graphical demonstration, let ob be the production cost for the monopolist-State and or the price set to achieve a tax equal to the shaded area, with the system of monopoly. If the industry open to competition produces at cost oa but the *collection cost* with another tax different from monopoly is higher, and the difference is greater than ab , then it is clear that in this case the State cannot achieve from the tax a *revenue equal* to the shaded area without further increasing or , and thereby causing a greater reduction to *consumer's surplus*.



Figura 61.

This surplus *would have been*: I) amD , in the case in which production takes place in a competitive system; II) btD , in the case in which production is reserved to the State, and this *does not* add the tax (or the extra charge br for the tax); III) by adding to its own cost (ob) this surcharge for the tax (br), the *denied* consumer's surplus (in addition to the sum going to the State) becomes equal to the triangular area stn ; IV) if the State had resorted to taxation of private firms at a cost lower than its industrial cost, replacing the higher *collection cost* for the difference of industrial costs ab , the denied "consumer's surplus" would be represented by a triangular area resulting from the *enlargement* of stn because of the further increase of price $nq' = or$ (necessary to obtain a similar level of tributary revenue).

From this point of view State monopoly can give rise to a favourable effect, that is to say, to the *differentiation of prices* so that they can remain in relation to the presumed extent of the incomes of consumers who are presumed to purchase goods objects of the fiscal monopoly, for which a range of prices are available, in relation to more or less fine quality, presumed to be more or less *fashionable* (illusion), of the taxed goods with the monopoly system.

Let's think of the existence of multiple prices for the various qualities of tobacco (quality of the leaf, curing, degrees of processing, brands and types "launched" with publicity designed to create "fashion", "distinction", etc.) and of salt (degrees of purity, more or less refined, ground, etc.). *If there exists a relationship between prices and consumers' surpluses*, the system of differentiation of prices should give rise to a *loss* of consumer's surplus *lower* than the one which would be in place if the sale of the product of monopoly was carried out at a single price. This is a consideration that might not be taken into account by the private monopolist who, *at parity of maximum net sum of revenue*, might not be concerned about the condition of maximum collective welfare that is implicit in the plans of the entrepreneur who aspires to this type of differentiation of prices. (Let's think about the arguments that, on the basis of Marshallian concepts, were presented with regard to "public price".)

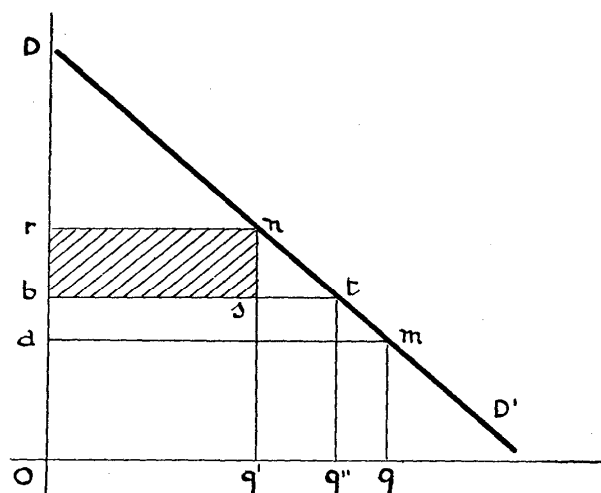
1) Let's consider (Fig. 62-I) the case examined through Barone's graphical representation that is completed here, when there is a *single price*, in a regime of fiscal monopoly. The consumer's surplus is given by the area $ABMN$ less the area that represents the revenue for the tax for the State. That is to say, the triangle ACN , which gives the residual income.

2) If the State, as monopolist, prefers to *differentiate* prices, presuming that there are consumers belonging to different income classes, it will establish two prices (Fig. 62-II) with respect

to the previous one, one higher (P) and one lower (N'), in such a way, however, as to leave *unchanged* the revenue for taxation $C'P'I'B' + RN'M'I' = CNMB$.



Figura 62.

That is to say, the sum of the two shaded areas (second graph) must be equal to the shaded area in the first graph. However, the area $A'B'M'N'$ is greater than that of $ABMN$. In this way, deducting from the area $A'B'M'N'$ the shaded area that represents the sum paid to the State (the same in the two cases), a *smaller* proportion of the consumer's *surplus* is taken away. This is equal to the sum of triangles $A'C'P'$ and PRN' , a sum of areas which is greater than the triangular area ACN (of the first graph).

Extending the same concept to the community, with the warnings given later with regard to “consumer's surplus”, it is possible to identify the benefit that the community derives from the State's decision to take responsibility, in a *monopoly*, for some productions for *fiscal purposes* and with the aim of *differentiating prices*. This is different from what it is presumed a *private* monopolist, aiming to adopt a single price, would do, with the objective of obtaining a maximum net profit and *disregarding* the repercussions of his behaviour on “consumer's surplus”, in other words, the arguments relating to the *welfare* of the *community*, as extraneous to the objectives of private entrepreneurs.

In other words, by the introduction of the concept of differentiation of prices on the part of the State, we have implicitly formulated the hypothesis that the governing class exercises *power* in the *interest of all* those who belong to a public group. This hypothesis corresponds to the type of “democratic State” identified by De Viti De Marco and to the corresponding case limit B) of political organisation taken into consideration by Fasiani but which, as has been demonstrated in the *Introduction*, is objectively logical in *itself*, whatever the type of State presumed.

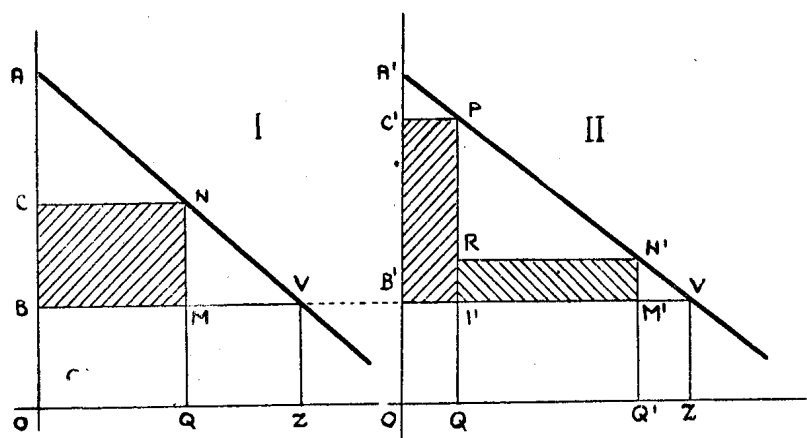
These considerations apply to private monopolies through which the State reserves the monopoly of production or the sale of specific *consumption goods*.

In the case of the *lottery*, the State derives a *non-equal* tax by implementing a public game. This is so in the sense (as it is known from financial mathematics) that the play (stake) is higher than the win multiplied by the probability of its being achieved. In the inverse case, the win is lower than the play (stake) divided by the probability of it being lost.

The tax therefore ends up being gradual in function of the sum of the theoretical win: in fact it represents 40% (deduction) of the win in the case of the “single extracted number” and of the “double” combination, 64% in the case of a set of three winning numbers and 88% in the case of a set of four winning numbers, to use an example drawn from a given period of the Italian organisation of this monopoly.

There has been much discussion regarding the morality of the game, contrary to the sense of duty that is found in work and in savings as well as in social benefits. However, until the moral and social education of the people influences in part the attitude – illustrated also in the chapter on the differentiation of taxable subjects – towards active survival, able to modify without effort and

improve the economic condition of individuals, and given that the absence of a public organisation would lead to private gambling, it appears to be preferable that the State collects a part of the sums (winnings) in the form of a tax to be used for public objectives (State expenditure), through a non-equitable system, subtracting it from private individuals who would otherwise organise gambling halls and lotteries, sums that also contribute to public offers.

IV.

COMPARATIVE BURDEN OF DIRECT AND INDIRECT TAXES, AT EQUAL COLLECTION LEVELS

The term “burden” is intended here in the sense of sacrifices represented by the loss of *utility*: in a hedonist sense, therefore, and *not in a monetary sense*, which will be considered in the theory of fiscal burden.

Having said this, there is no comparison in these pages between the types of imposition for the loss in terms of “money”, such as the one that was carried out, for example, by U. Gobbi, who had concluded that both the direct and indirect tax give rise to an equal loss of money (and of income) for the consumer.

However, we start from the known theory as pronounced by Pantaleoni, using the hedonistic concept of marginal utility. It is presumed, furthermore, that we are dealing with a tax, respectively direct and indirect, that has *already affected* the taxpayer, as subject whose *income* and *tastes* do not change, with respect to the theoretical case that is examined here.

I draw from Pantaleoni’s own words the details of the expression of the equality of burden of the two types of tax at parity of collection, to rebuff criticisms that are aimed at the conclusion and to highlight cases, considered by other authors, where the mentioned equality might exist. Finally, I highlight a generalisation of the same theory, and the criticisms levelled at it.

1) Pantaleoni²¹⁰ starts by stating: *a)* that “the distribution of income of a *homo economicus* among the various uses he can make of it is not controversial. This distribution, as everybody knows, will be such that its utility in any type of use will be at the prices of marginal doses in the same proportion; in other words, the marginal utilities of every use will stand in the same relationship to each other as that which exists between the prices of marginal doses”.

b) “From this it follows that it is *irrelevant* for a *homo economicus* that the price of one or other goods among those consumed by him increases or decreases. Regardless of the product whose price has been varied, an *ex-novo* redistribution of this income among all the previous and also among the new uses that were only “virtual” before the variation will follow: this redistribution will represent an economic process that will not be stopped until the (*previously mentioned*) condition of equilibrium has been realised.

c) “It is clear that the effect produced by the *incidence of a tax* or tax on one or other of the objects of consumption is only a particular case of the effects of price variation. It is therefore *irrelevant*, in pure economy, whether the product taxed is one of those normally referred to as prime necessity items or whether it is instead a luxury product. All marginal goods are luxury goods. The pressure of the incidence in one case or another will be distributed on all marginal consumptions. It is also *irrelevant whether a product consumed by homo economicus is taxed, or whether the personal tax affects his income directly: a redistribution of his now reduced income will always take place, a redistribution which will reject the sacrifice on all marginal consumptions, regardless of the consumptions affected by the tax or tax.* Therefore, in pure economy, taxes or taxes more *onerous* than others do not exist at the same level of income absorbed, and all taxes will affect only consumption of

²¹⁰ In the well-known essay, titled “*L'identità della pressione teorica di qualunque imposta a parità di ammontare e la sua semiotica*” [*The identity of the theoretical pressure of any levy at comparable levels and its semiotics*], already published in the “Giornale degli Economisti” [Economist Journal], March 1910, and later included in the volume *Studi di finanza e di statistica* [*Finance and statistics studies*], Bologna, Zanichelli, 1938.

luxury items; that is to say, they are transferred by each individual where they might end up being less painful.”

d) “To ensure a true redistribution of income, following a tax or a price variation, and therefore real indifference of the taxpayer or the consumer with regard to the type of tax that affects him, it is necessary that it meets the reality of the hypothesis that he is master of his own budget.”

“It is necessary, furthermore, that the hypothesis that the taxpayer – or the consumer – can readily transform some consumptions into others, is not prevented from so doing by contracts in existence or by indivisibility of goods or the arbitrariness of prices and therefore by the inexistence of quantities smaller than those used up to now.”

Having expressed these cautions and others that condition the deduction with respect to the identity of the burden of any tax at parity of the collected sum, in the quoted essay Pantaleoni attempts a semiologic verification of the uniformity expressed through deductive reasoning.

The uniformities just mentioned have been criticised by some. Other authors (keeping in mind a retractable expression of Marshallian concepts that I have qualified as being equivalent to those of Pantaleoni) have identified cases in which the theory that claims the identity of the theoretical burden of the two fundamental types of taxes might logically occur. Other limit-cases will be indicated in the sense of converging with Pantaleoni’s theory.

2) I will start with the *criticisms* raised by Italian academics.

A) Barone graphically presented the demonstration that there is *no* verification of the identity of theoretical pressure because, *at parity of sacrifice by the individual*, the *inland revenue receives* less with the *indirect* tax than with the *direct one*; if the same level of collection is required, the inland revenue must raise the price so that the taxpayer is compelled into an indifference curve lower than the one indicating equality of sacrifice.

Going over Barone’s argument, with some additional clarification, and keeping in mind the geometrical demonstration, let’s presume the case of the beneficiary of income-consumer, who has an income represented by the straight line OA , able to purchase a unit of goods A , represented on the same abscissa, with each unit of income. Let’s presume that he has the possibility of also purchasing another product B , and that the exchange rate is such that $1/2 B=A$. (That is to say, the length of segment OA is *double that of* OB , in the diagram.)

Having said this, there will be possible combinations of the quantities of product A (exchangeable) with that of product B along the line AB , compatibly with the preferences of the subject. Among all the combinations, as can be deduced from the concept of the “indifference curve”, there is one which achieves the maximum satisfaction. This is represented by the point that identifies the two coordinates of the quantity, that is to say, the one in which the straight line AB is tangential to the indifference curve I , of higher index. In the diagram, this is point C , to which correspond quantities Os of B and Os' of A .

Let’s presume that when the subject has reached an equilibrium within specified constraints, the State decides to *reduce* his income by a certain quantity, through the application of a *direct tax* that, without having an influence on the reason for the exchange, leads to a reduction of the same income (with which he can purchase the quantity OE or OF) from OA to OE . The line parallel to AB , which originates in point E at which the tax has limited the income, meets the ordinate axis at point E' . This straight line will be *tangential* to the “indifference curve” II with lower index, precisely at point D . The tangential point identifies another combination, in which the subject purchases Ot of A spending Ot , and Ot' of B , spending tE .

Let’s presume (for the purpose of the comparison to establish the divergence of burden of the two taxes, respectively on income or on one type of goods) that the State decides to *no longer* collect a *direct tax* on *income*, but one in the shape of the *increase in price of one of the two products* (for example B), *without inducing a greater sacrifice in terms of utility*. In this case the new price line (AP) (which derives its origin from point A , as income is OA) should end up *tangential to the same “indifference curve”* to which the straight line starting from E is tangential (after the collection of income EA for the direct tax).



Figura 63.

The tangential point will be G , to which will correspond the combination of consumption $HG = OQ$ of goods B , spending HA of income, and the quantity OH of goods A , with an expenditure OH of income.

At this point we ask ourselves if the *revenue for the State, at parity of sacrifice* (parity that derives from the subject being on the same indifference curve II), ends up *the same or less* than the one that can be obtained through the application of a *direct tax* of extent EA , as has been seen. Given that the collection of the *indirect tax* is presumed to take place through the *increase in the price* of goods B , it is necessary to see to what extent this increase has taken place. From the diagram it is the case that the sum spent to obtain the quantity GH of B is HA (of income OA). What was the price of the same quantity of B , that is to say, of HG , in the initial case, where the straight line AB determined prices? As IK is the same as GH , the quantity of income that would have been spent, *before the price of B increased* (with the tax), would have been KA .

Let's calculate the *difference* between the income spent after the increase of price of B , which we have said is equal to HA , and the income that would have been spent in the absence of the tax that has increased the price, which is KA , and we obtain HK , which is the *sum that goes to the State in the form of indirect tax*, for the quantity GH of B consumed.

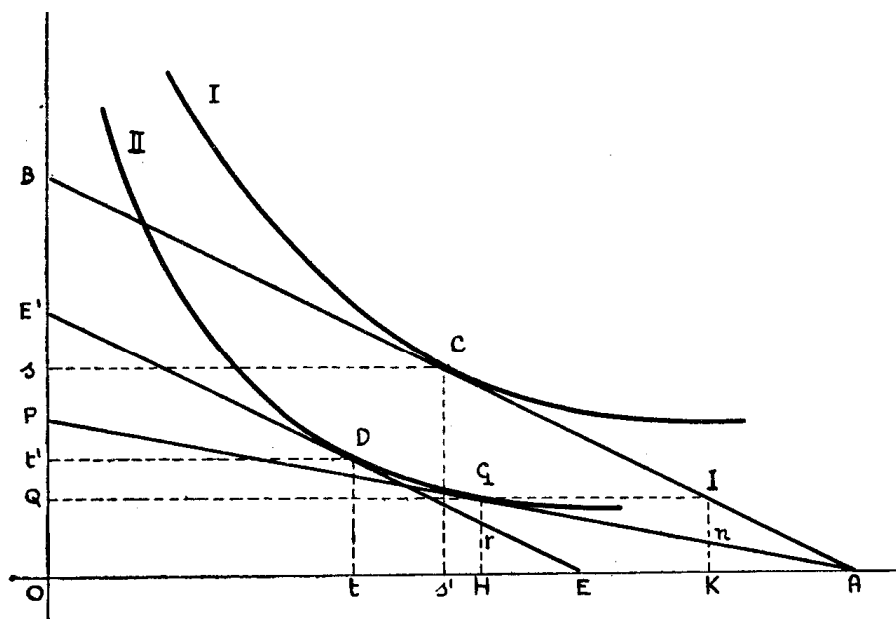
From the immediate observation of the quantities indicated in the diagram²¹¹, the result is that HK is less than EA . That is to say, with the *indirect tax* (HK) the State obtains a sum which is *less* than the one obtained in the hypothesis of the application of a *direct tax* (EA). Inverting the argument, if the State wanted to obtain an *equal sum of tax*, it should increase the price of B further, so obliging the beneficiary of income-consumer to choose less desirable combinations, that is to say, along an indifference curve of an index inferior to that of II that has been considered in the diagram. Thus this demonstrates Barone's premise, that is to say, that there is *no identity* of pressure (in hedonistic terms) between the two types of imposition (direct on income and indirect on goods) at parity of revenue collected by the State.

The demonstration that I have given here, based on Barone's model, is more diffused and less concise than the one provided by the illustrious economist. However, by sacrificing concision it was hoped the student would be offered a clearer and easier identification of the elements of the argument.

B) To these arguments are added Borgatta's criticisms, which I broadly summarise by saying, empirically, in my view that: I) the *goods* are *not* in practice *divisible* into *infinitesimal units* so as to implement, after the tax, the surrender of marginal portions of them; II) from what I believe to be a

²¹¹ In the similar triangles rHE and IKA it is $HE < KA$; therefore it will be $HE + EK < KA + EK$.

rational point of view, that consumption *goods* are *interdependent* and linked by relationships of *complementarity*, *surrogacy*, of production at *combined costs*, etc.; in this way, when a tax affects one of them, varying its price, the *relationship between prices* and the *proportions* in which goods linked by complementarity, surrogacy, etc., satisfy such needs are disturbed, as this is an element that influences the distribution of income to different forms of consumptions.

The *relationships* between prices, however, *are not* disturbed by the *direct* tax on income, which is presumed to obliterate a sum of relatively lesser utility than the indirect tax.

Some limit cases, in which the *identity of pressure* may occur, have been identified by different authors, of which I recall some.

C) Fasiani and M. F. J. Joseph²¹² have put forward *particular hypotheses* relating respectively to the relationship of substitution of goods or elasticity of substitution (between given goods and income), to demonstrate cases in which, at parity of collection with the two types of tax indicated above, it was possible to determine parity of sacrifice in hedonistic terms. In particular, the limit case in which identity of pressure would take place would occur in the system of indifference curves, at the point in which the “elasticity of substitution” is *zero* (form of *broken* curve, with a branch parallel to the x-axis). In this case the increase in price (due to the indirect tax on the taxed goods) and the reduction of the initial income (because of the direct tax on income) have the same effect on the quantity demanded. In practice the portion spent on taxed goods should represent a small part of income. (To avoid the additional burden of subtle, also graphical, demonstrations of exceptional cases, I refer the reader to the original writings, indicated in the notes, which I compared in the essay “*Sviluppi di un teorema finanziario*” [*Developments of a financial theory*], etc., quoted, to identify analogies of ideas between the two authors, before presenting my view on the subject.)

D) U. Ricci²¹³ examines the limit case in which the taxed goods have an *absolutely inelastic demand*. In the case of this hypothesis, when faced with the increase in price determined by the tax, the taxpayer-consumer would *not* at all reduce consumption of those goods, and would procure the sum necessary to maintain unchanged his consumption of those goods so exclusively reducing other consumptions. In this case, it would be *irrelevant whether the individual was to be subject to an indirect or a direct tax*.

E) U. K. Hicks reasoned in the same way, resuming Marshall’s argument, according to whom when the demand curve is essentially rigid, the State does not obliterate “consumer’s surplus” in collecting a tax on goods greater than the sum that it collects as a tax. Using the logical instrument of the indifference curves, without defining them but mentioning the combinations of goods corresponding to degrees of elasticity of demand, this academic reaches the conclusion that, when types of goods are subject to *absolutely inelastic demand*, a tax on them is equivalent to an income tax of the same amount²¹⁴.

In fact, making the contrarian argument, this academic warns that if the demand for the taxed goods were to be *elastic*, the consumer would buy less of them; and because it is a premise that it must be subject to a *given* amount of tax, it must be admitted that the same subject purchases quantities of other taxed goods, which had in the past been *discarded* as having a *lower index* of ophelimity (in the sense of indifference curves with a lower index or of less desirable combinations).

Or, to remain with the hypothesis that presumes as *given* the amount of tax, it is possible to present the alternative that the consumer taxpayer bears the expected burden, charged only to the reduced consumption or of taxed goods with an elastic demand. However, I believe that in any case he will experience a loss of satisfaction with respect to the choices of goods with greater ophelimities, regardless of the tributary relationship based on the taxation of goods with elastic demand, where he would not modify his consumption of the taxed goods if they had an inelastic (rigid) demand.

²¹² See the subtle arguments by Fasiani in the article *Di un particolare aspetto delle imposte sul consumo* [*Of a particular aspect of consumption levies*], on “La Riforma Sociale” [Social Reform], January–February 1930, and the rigorous observations by M. F. J. Joseph, published in Volume VI of the “Review of economic Studies”, 1938-39.

²¹³ In “Economist Journal”, September 1938.

²¹⁴ *The finance of British Government*, 1920–1936, London 1938, pp. 253-254.

In essence, Hick's arguments are along the same logical lines as those of Prof. U. Ricci, recalled above.

F) Numerous other academics have dealt with the issue of comparative pressure of direct and indirect taxes, furthermore without uniformity of conclusions. Among more recent works, on which it is not opportune to pause at this point, I recall those of J. R. Hicks (*Value and Capital*, 1939, *op. cit.*), H. P. Wald (in "The Quarterly Journal of Economics", 1945), G. J. Stigler (*Theory of price*, 1946), E. D. Allen and O. H. Brownlee (*Economic of public finance*, 1947), K. E. Boulding (*Economic Analysis*, 1948), A. Henderson (in "The Economic Journal", 1948) and others.

It is to be noted that, generally, the well-known authors above give proof of ignoring Italian works on the issue in question, and in particular Barone's contribution, essential as a *general* view, quoted. This is said, for example, to quote the more recent case, of Milton Friedman who, in the article *The "welfare" effects of an income tax and an excise tax* ("The Journal of Pol. Ec.", February 1952), for rather debatable reasons, makes the comparative effect of *income taxes* and of *excise taxes* dependent on *welfare* from the initial conditions in which the imposition is introduced, with clear modification of the traditional hypotheses of the theory in object.

Furthermore, to quote a relatively recent Italian work, I recall that comments giving value to cases of identity of pressure are contained in the essay by A. SCOTTO: *Sulla pressione comparata dell'imposta sul reddito e dell'imposta sul consumo* [On comparative pressure of the tax on income and the tax on consumption] (Collana della Facoltà di Ec. e Comm. di Genova [Series of the Faculty of Economy and Commerce of Genoa], 1947).

G) A *negative* formulation of the theory of the *identity of pressure* (with a conclusion that generalises, that is to say, a *divergence* of pressure in terms of sacrifice of satisfactions or of utility) has been put forward with subtlety of argumentation by Prof. H. Hotelling²¹⁵. Unlike Pantaleoni (and his critics and followers), however, he does not take account of a *given tax on an item of expenditure*, but of a *system of taxes on consumptions or on goods*, referring the statement first to a single subject and then to the entire community.

"If one person must pay a certain sum of money for a tax, his satisfaction will be greater if the collection is made directly from him in a given amount, than it would be in the case where it is carried out through a system of taxes on goods (excise) where he can, within limits, avoid readapting production and consumption." There is a *loss* for the single individual in readjustment, without corresponding earnings for the State.

I do not consider here the generalisation to the entire community, to avoid introducing further elements of divergence from Pantaleoni's theory.

The author hypothesises, for *n goods*, a system of *hyperplanes* in an *n-dimensions* space, in which the *Cartesian coordinates* are the quantities of the *goods* whose consumption gives the individual the same satisfaction overall.

These hyperplanes are, therefore, to be considered as *places of indifference* in an analogy to what we know of the curves of the same name.

Having said this, the individual will choose a combination of goods that maximises the value of the utility function $Q = Q(q_1, q_2, q_3, \dots, q_n)$ of quantities q_1, q_2, \dots, q_n of goods and services consumed by the same individual, compatibly with the equation of equilibrium $\sum p_i q_i = m$, where P is the prices of the goods and services and m is the monetary income. In other words, the optimum combination will arise from the point of tangency of an indifference plane with that of equilibrium.

If we take the hypothesis that a tax on income of the amount t is collected, the equilibrium will be established in a point which will lie hypothetically (as M is the point of the "indifference locus" with a higher index) *on a place of lesser indifference* (M'). This emerges from R. Frisch's representation²¹⁶ and, even though it is conventional (in that it is not a diagrammatical representation in which there are coordinates, in the Cartesian sense), it can serve to give a *visual* idea of the change that is caused in the conditions of equilibrium of the hedonistic consumer, because of fiscal causes.

²¹⁵ H. HOTELLING: *The general welfare in relation to problems of taxation and of railway and utility rates*, in "Econometrica", July 1938.

²¹⁶ R. FRISCH, *The Dupuit taxation theorem*, in "Econometrica", April 1939.

[I underline the word “visual” for the representation, to highlight the anticipated conventionality. Indeed the graphical or diagrammatical representations are not possible when dealing with three or more variables. However, academics of mathematics applied to economic science admit that it is sometime opportune, nevertheless, to use geometrical terms also in the formal analysis of the functions of more variables. However, the use of these terms is purely *descriptive* and done in analogy with the case with three variables. So a group of values $(x_1, x_2, x_3, \dots, x_n)$ is defined as the *point* in *n-dimensional* space, referred to as *n-axes*, mutually perpendicular and every relationship between variables is described as a hyperplane. This concept includes a straight line (two dimensions) and a plane (three dimensions) as particular concrete cases.]



Figura 64.

As can be seen, two points are identified where the *plane of equilibrium* of the consumer is *tangential* to the *point of indifference*. An indirect tax of equal amount would compel the consumer to a combination of even less utility.

For R. Frisch, however, given that the *sum t* of the direct or indirect tax, that is to say, on income or on goods, is *equal in the two cases*, the tax on goods, if hypothesised as *proportional to original prices* (P_0), has the *identical* effect of a *direct tax on income*. Therefore the point of maximum satisfaction would be, in the two cases, the point M' regardless of the extent of the taxation on goods (at parity of collection), as long as there is the anticipated proportionality (*which does not disturb the relationship between prices*, a rational condition that Borgatta, as has been seen, put forward against the opposite conclusion derived from Pantaleoni's demonstration). Only when there is *no* hypothesis of indirect taxation on goods proportional to original prices is it possible to demonstrate that there is a loss of satisfaction in replacing the direct tax on income with the indirect imposition on goods.

Even though it is a matter of an approach different from that of Pantaleoni, R. Frisch leads to an *equivalence* between direct and indirect imposition as general and uniform tributes. This is an equivalence that, indeed, traditional theory had sensed in the comparison of a general and indirect tax according to value on all consumptions (of goods and services) with the general tax on income.

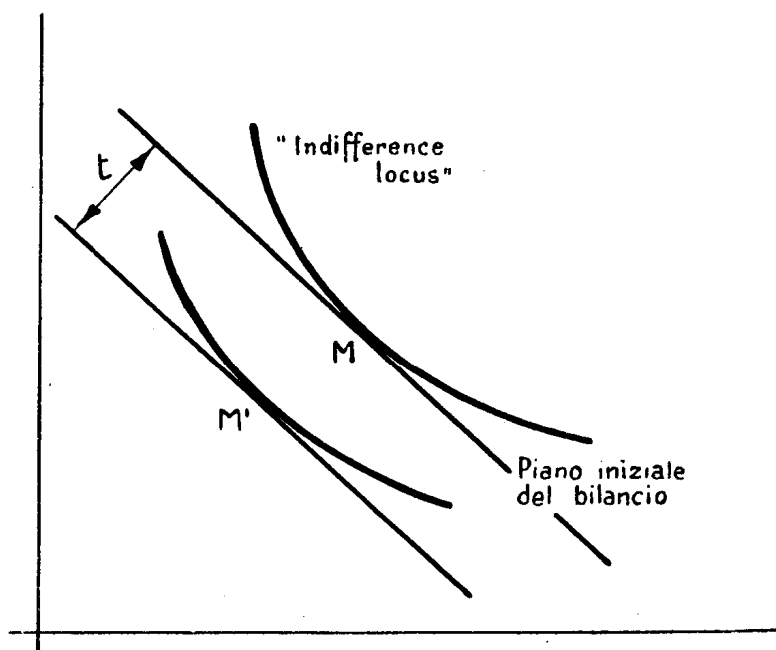
[With regard to Pantaleoni's theory, arguing by absurdity, Ricci had also made the hypothesis that there may be identity of burden between the direct and the indirect tax when the first is *transformed* into a system of indirect taxes, and therefore into a system of as many indirect taxes as the types of goods of which each individual reduces consumptions of, as an effect of the direct tax,

and that each new indirect tax reduces the partial consumption exactly by the same extent that the direct tax would have done.]

We are in a field where the type (qualitative element) of imposition can be designed so as to give rise to indifference of burden of distinct systems of imposition.

Essentially, as I demonstrate in the essay on the subject in hand, Prof. Hotelling, admitting that taxation of goods, *proportional to prices*, when these are *equal to marginal costs* (the hypothesis of ideal competition is not, however, required, as I made clear at the time) would not disturb the relationships between prices, in the same way as they are not disturbed by direct imposition, ended up contradicting the expression in the negative sense of the identity of burden of the two types of taxation, and to welcome R. Frisch's approach that, to be precise, represents a revision of premises more than a criticism.

V.

RELATIONSHIPS BETWEEN THE PREVIOUS THEORY AND VISIONS OF MAXIMUM COLLECTIVE WELFARE

In the context of initial or expanded premises, the demonstration of the Pantaleoni-type theory or its rebuttal sheds light mainly on the condition of maximum satisfaction or of *equilibrium of the perfect hedonist*, expressed in the sense of the equality of ophelimities considered or of the equality of relationships between respectively marginal utilities and prices.

However, as I have demonstrated (in the quoted essay entitled *Sviluppi di un teorema finanziario e sue relazioni [Developments of a financial theory and its relationships]*, etc.), there are also conceptions of *maximum welfare* or *collective optimum* (in which the condition of maximum satisfaction of the hedonist, as defined above, is presumed to be absorbed) that in a logical-instrumental way use the tributary factor, *not necessarily* configured from a *qualitative* point of view (direct or indirect tax), but considering the *quantitative* aspect (the "quantum" of the collection and its destination). For these models the demonstration of the identity of the burden of taxes of different types does *not* have the value of *necessarily primordial uniformity*.

The main objective of that survey was to: *a)* demonstrate the need to limit the validity of the "standard ways to perform" that are derived from the solution of a theory or problem, obtained through deduction in an argument whose limits have been fixed by specific hypotheses, whose value in the rational field does not seem to be adequate for reality²¹⁷; *b)* particularly, to *demonstrate that the qualitative element* (form, species or type of tax: direct or indirect), an element that has been the *necessary* premise in relation to the Marshall- or Pantaleoni-type theory, *may be, in fact, disregarded in relation to the problem of maximum collective welfare, in the expressions that confer instrumental importance on the tributary element from the quantitative point of view.*

Having mentioned the Marshall-type approach of the well-known theory explicitly formulated by Hicks, I have highlighted, in the second part of the quoted essay, the lack of convergence of "the standard ways to perform", which use the solutions of different financial theory problems with the objective of finding a solution to the problem of maximum welfare.

Indeed, in the space of a few consecutive pages of the excellent essay by Marshall, it is possible to find two relationships between the conclusions derived from financial theories and the approach to problems of maximum satisfaction, referring to the community.

a) Disregarding the law of costs, and concentrating on the conclusion of the problem of pure finance (according to which, I recall, having hypothesised a "given sum for the tax" that has to be collected, the loss of "consumer's surplus" will be less if the tax is collected on goods whose demand is essentially rigid), Marshall moves without hesitation to the "standard way to perform" of financial

²¹⁷ I carried out one integration of Barone's "standard way to perform", in the range of the "resultant" deriving from the application of direct and indirect levies, from another point of view in "Annali dell'Università di Ferrara" [Annals of the University of Ferrara], 1937, in the short essay entitled *La determinazione della risultante del Barone e i dati del problema finanziario [The determination of Barone's resultant and data of the financial problem]*, whose content is considered in the next paragraph.

policy, suggesting the taxation of “necessary” goods. Through Hicks’ formulation, quoted, which derives logically if not formally from Marshall’s one, we have reached, as has been seen, the generalisation of the identity of burden in the case of the direct tax on income.

b) Furthermore, we have just read with interest how the expression of what is par excellence the theory that uses the tributary element in the search for a condition of maximum welfare or collective advantage relates to the premises of the expressed “standard way to perform”, when we come across it in *Principii [Principles]* (p. 460), in relation to the introduction of the hypothesis of increasing and decreasing costs.

In fact, with the objective of indicating the way to increase the total satisfaction for the community through the least possible destruction of “consumer’s surplus”, Marshall – as we have seen in paragraph IX of the previous chapter, where the analysis of the effects of the imposition in relation to the variations of the consumer’s surplus is carried out – suggests a “simple plan”. According to this, the community should “impose a tax on the incomes of its own members or on the production of goods that obey the law of decreasing productivity, and then use the product of the tax to create a production premium for those goods for which the law of increasing productivity applies strongly”.

The institution of relationships between given tributary collections and their destination for the purpose of increasing collective satisfaction suggests two considerations: a) on the one hand, through the alternative expression (“or”), an identity of burden between the tax on income and taxes on goods subject to the law of increasing costs is implicitly established. This ignores the decisive circumstance (elasticity of demand of taxed goods), without which (trend rigidity) the identity of pressure that Hicks had explicitly reached by developing Marshall’s argument fails; b) from the point of view of the obliterated (or capable of being increased) consumer’s surplus, taxes respectively on goods subject to the law of increasing or decreasing costs (conditions of the supply) are compared, disregarding their respective elasticity of demand. Clearly this condition, if considered at the same time, could contradict the level of maximum satisfaction. In other words, Marshall faces other circumstances that “in practice can influence the introduction of a tax”: however, in putting forward the “level” that could, as was said in the theory, appear to be appropriate for raising total satisfaction, he disregards the condition represented by the degree of elasticity of demand of taxed goods. This condition, as was seen in the previous pages in light of another theory, would suggest a different “standard way to perform” in place of the utilisation of tributes in the context of an ultimate situation of maximum satisfaction for the community.

With a wider interpretation of Marshall’s integral argument, it is possible to presume a case limit in which the two conditions (elasticity of demand and law of costs) hypothetically (and historically) act simultaneously, univocally converging towards the same objective of the lesser obliteration of consumer’s surplus and to variations of this entity (“surplus”), believed to be typical of a situation of maximum welfare or maximum satisfaction in Marshall’s sense. However, this hypothesis was not put forward in the *Principii [Principles]*. And even if it were put forward in the format I have concisely formulated here, it does not represent a premise that logically legitimises two different “standard ways to perform”.

A significant coincidence is useful in confirming the relativity of the theoretical deductions from particular finance problems and the limitations that would impinge on their application to problems of research of abstract situations (or translatable into practice) of maximum collective satisfaction, or in maximum general welfare, etc.

I am precisely referring to the “instrumentality” of taxes on incomes and on successions, with respect to the objective of the achievement of maximum “welfare”, according to the plan that emerges from Pigou’s well-known treatise²¹⁸.

The synthesis, necessarily imperfect because too restrictive of Pigou’s thinking, can in this way be summarily traced, from the point of view of the recourse to the tributary instrument in relation to the plan of maximum collective welfare: 1) economic welfare, as a set of satisfactions, is a concept

²¹⁸ *Economia del benessere [Welfare economy]*, in the translation published in the recent edition of U.T.E.T., *op. cit.*

coordinated with that of the national dividend; 2) welfare is normally linked to the use made of the volume of national dividend consisting in a certain set of goods and services that are created during a given period; 3) as long as the portion of national dividend that is destined for poor classes does not diminish, each increase in national dividend occurring without the contrary action of other phenomena must indicate an increase in economic welfare; 4) as long as the overall dividend does not diminish, any increase in real income enjoyed by the poorer classes to which corresponds an equal decrease in income enjoyed by more affluent classes, certainly leads to an increase in economic welfare; 5) because in the current climate voluntary transfers of wealth are much lower in extent than the quantity considered to be necessary by the community, the need arises to introduce taxes and nearly always taxes that affect owners of large patrimonies and great incomes; they will often be taxes on income and on successions; 6) indirect transfers of income, among other things, through premiums (obtained through taxes) in favour of the consumption of specific goods purchased mainly by the poorer classes or restricted to that part of overall consumption that is effectively enjoyed by specific categories of poor people, can be found alongside direct transfers of income; 7) any specific transfer of means from wealthier to less affluent classes must (leaving aside the reactions discussed by Pigou in the course of several chapters) in itself increase the future national dividend, as long as the rate of return of investment intended to increase the productive ability of poorer classes is not lower than the rate of return of investment in capital instruments: it should not be approximately less than the standard rate of interest.

Even though Pigou, generally speaking, works in a logical order of Marshallian flavour, his model of “*general welfare*” uses arguments that are not those deriving from the “original ideas” on which the theory of the identity of pressure is based. After an ample demonstration of the premises, Pigou arrives, among other things, at the expression of “*standard ways to perform*” which includes, as rationally instrumental factors, the same taxes whose collection and destination are not in the same logical line of argument and even less so of the type of reasoning of Hotelling and his critics and precursors.

The independence of the problem set by Pigou from the one put forward by Hotelling is very clear, although both have as their objective the search for a condition of maximum “*general welfare*” and instrumentally contemplate the recourse to the same tributes for the same objective. However, Hotelling links the relationship between the tributes recalled and “*general welfare*” to the validity of the fundamental theory with a negative solution with regard to identity of pressure. In any case he contrasts, from the *qualitative* point of view (at parity of collection), the tax on income and the tax on successions (which had been considered equivalent in a way to the former) to the imposition on goods. There would appear to be a problem of *qualitative* choice of the compared tributes in Hotelling’s approach to the well-known theory, and in that of others, in light of the effects of collection with respect to the plane of equilibrium of perfect hedonists. As has been seen, the logical bases of the preferability of one tax (direct) over another (indirect) are too restrictive and greatly controversial, in other words, the premises of the indifference in the alternative choice of the two types of tributes in order to establish the basis of a general “*standard way to perform*” of the type of those that finalistically lead to the maximum collective welfare on the verification of the validity of the Marshallian²¹⁹ or Pantaleonian theorem or their respective denial.

Pigou does not make any reference to the theories highlighted in these considerations when he considers the instrumentality of the two taxes (on incomes and successions) in the plane of collective welfare. However, given an unequal distribution of incomes, he believes the collection of a part (*quantitative* element) of incomes and estates to be desirable for the community, discounting (as effect) the greater productivity (in objective terms) of the destination of the sums collected, with respect to the objective of maximum increase in national dividend, a factor coordinated to the collective welfare.

The logical validity of the “plan” elaborated by this author is therefore not linked to the validity of theoretical assumptions in the context of pure finance. As only the “technical” quantitative

²¹⁹ I am referring to the one on the pressure of levies on goods, which can be considered to be identical to that of the levy on income.

datum is drawn from the tributary field, its coherence with the model of maximum collective welfare rests on premises to be demonstrated but not restricted and controversial to the same extent as those linked to the quoted financial theory, in the different formulations.

From another point of view, the institution of a logically instrumental relationship between the conceptual application of the tributary factor and: *a*) the theoretical Paretian conception of the maximum ophelimity of a collectivistic State; *b*) the attempted reconstruction of pure economy carried out by De Finetti, to quote two mental abstract positions with regard to the theme of maximum ophelimity and of “optimum”, similarly escapes this type of criticism

a) From the logical-abstract (and not naturalistic) point of view, that is to say, as a hypothetical study of possibilities and of virtual consequences deriving from given premises, Pareto²²⁰ set the problem of identification of a condition of equilibrium in which members of the community achieve the maximum ophelimity²²¹. Limiting himself to considering the problem of production, Pareto formulated the hypothesis of the easier achievement (than in regimes of free competition) of the line of “complete transformations” as the point of equilibrium. To reach such a condition in a “non-collectivistic society”, according to the illustrious theoretician, this society “should make clients pay first of all for general expenditure and, then, sell goods at cost price, once general expenditure has been deducted”.

This procedure rightly appeared to him to be difficult in practice, creating the hypothesis of a “private society”; on the other hand, in the hypothesis of a “collectivistic society”, the (socialist) State “can charge consumers a tax on its own goods for the general production expenditure of those goods, and then sell them at cost price; that is to say, it can follow the line of complete transformations”²²².

At first sight it would appear to have come to an expression similar to that of Prof. Hotelling, who²²³ formulated the “*standard way to perform*”: that the tax on income (and successions) could be destined to cover the fixed costs of industries, which have to meet extensive general expenditure for their plant, so as to reduce the prices of services and products of the respective industries to the level of marginal cost.

First of all, however, it is to be warned that Pareto did not formally specify if this were to be an imposition proportional to the price or to the quantities of goods or to income (distributed according to “some ethical-social principles”), even if this qualification of the tributary constraint of equilibrium can be induced indirectly. Furthermore, and in particular, he does not contrast the tax on income with a tax on goods (even if general expenditure, for example, considered as uniform increase of the marginal cost, can be made equivalent to a tax on goods).

If desired, with a logical effort and with a certain degree of arbitrariness, it is possible to direct the Paretian “standard way to perform” along the lines of Hotelling’s arguments: the substitution of a tax (hypothetically on income) to general expenditure that would otherwise have to be paid pro-rata through the sale price of goods. However, Hotelling expresses and demonstrates the theory of the convenience “for each person of a State of the abolishment of taxes on goods and the respective substitution with the direct tax on income, at parity of collection.” A theory that – I repeat – denies the identity of pressure, a theory based on the *technical-qualitative* characteristics of contrasting tributes, and which is not included in Pareto’s model, not even implicitly.

In the concern of expressing the condition of a maximum ophelimity in a collectivistic society as appropriate to the integral realisation of the regime of “complete transformations”, Pareto considered the tributary factor, from the *quantitative* point of view, as being completely incidental or logically instrumental (to clarify the concept, I would add here) and in a schematic way. On this subject, from the point of view considered here, further clarifications would have been useful on the part of the great thinker, who left the determination of such details to the reader. However, the

²²⁰ In *Manuel [Manual]*, pp. 362-65.

²²¹ In the “Appendix” to the *Manuel [Manual]*, Pareto adopts a term here alternatively used with other equivalent ones in defining the maximum ophelimity as the “greatest welfare” possible for members of the community.

²²² It must be kept in mind that in the Paretian hypothesis “prices” are accounting and not real entities, necessary to the organisation of production.

²²³ In the first article, quoted, published in “*Econometrica*”, 1938.

interpretation cannot go further than the limits of a shifting in explicit terms of what is implicit in Pareto's approach, on this point. Free of the deduction deriving from financial theories postulated by other authors, the expression considered here is coherent also with respect to the choice of the tributary instrument whose *quantitative* influence must, because of the thesis, be resolved in an ultimate increase of ophelimity, such as to lead individual members of the hypothetical society to a maximum of ophelimity.

b) Partly analogical considerations apply with regard to the logical-instrumental position of the tributary factor in B. De Finetti's schematic attempt, aimed at overcoming the approach of classic economy.

I refer the reader to the striking essay²²⁴, and I will limit myself to recalling that the new version by this author insists on the object of economic science as the study of the problem of the "possibility" of satisfying desires and needs, independently from each hypothesis' particulars on juridical, economic, political and organisational institutions, which are characteristic of a specific historical time.

De Finetti formulated the hypothesis, among other things, that production is brought about by the work of private individuals, who sustain the expenses and enjoy the profit on the basis of prices that have the meaning of "constraining parameters", that is to say, concepts having sense not with regard to the economic problem intrinsically considered, but only with respect to specific systems of economic organisation²²⁵. Having said this, and having taken account of other conditions, which are omitted for brevity, it appears to be possible to obtain a generic situation of "optimum" whenever an adequate balance of the initial situations is carried out, so as to take away from the judgment of convenience of the hypothetical entrepreneur all those elements that do not contribute to marginal costs. According to the author, it is necessary to purify all the linear functions of the constant terms and ensure the equilibrium of all individual situations in correspondence of the "optimum" point, with the consistent redistribution to confiscate all excesses and refund all deficits that the hypothetical accounting of costs and revenues would generate with respect to constant entities precisely at the point of *optimum* considered.

By avoiding the need for the "optimum" point to coincide with the break-even point, it is also possible to formulate the hypothesis that the price is not different from the marginal cost, as producers would be compensated for the loss deriving from not having fixed expenditure taken into account in the price. All this implies a single regulatory "plan" in which everyone enjoys the set of goods available, so that the condition of "optimum" is approached. Wanting to remain in the context of current concepts, De Finetti considers, among other things, an achievable policy of redistribution for the realisation of the plan, for example, through the tributary system²²⁶, to cover the apparent losses for producers compelled (for the equation of "optimum") to sell goods at a loss (or at marginal cost) and to collect the corresponding profits.

According to an unpublished further clarification of his argument, the author did not see the recourse to a direct general tax on incomes (admitting a resolution to the problem of the determination of what is meant by income in the case of entrepreneurs whose losses are refunded, in the previous meaning) as being incompatible with his conception of "optimum". The revenue of this tax could be destined for the refund of the losses to producers in the sense recalled above. Consumers would purchase goods and services at a price equal to the marginal cost. Given the different "weighting" of "general expenditure" in the different production of goods and services, there would be a diffusion to the benefit of consumers of the effects of the law of decreasing costs, with an increase in the utility of goods (or of the "consumer's surplus", I would add).

After what I have specified – as my thesis, which guides this paragraph V (and my quoted essay, to which I refer), and whose logical necessity had not been previously felt in the theory – with

²²⁴ Entitled: *La crisi dei principii e l'economia matematica [The crisis of principles and mathematical economy]*, and is included in the "Acta Seminarium" of the Economy Institute L. Bocconi of Milan, 1943.

²²⁵ See Pareto's analogous hypothesis quoted earlier in the notes.

²²⁶ This type of redistribution, in the context of the hypothesis of maximum ophelimity in the collectivistic society, does not appear to be arbitrary to Pareto, who introduces it as a logically instrumental condition for a mode of virtual achievement of maximum ophelimity.

regard to Pareto's logical position, from which De Finetti's position is not very different in respect of the particular aspect I consider here, even in the context of its autonomous model, I do not insist in highlighting my assumption. That is to say, *the independence of the close examination of the effects (on welfare in a hedonistic sense) of the redistribution of wealth for any (qualitative) tributary mode, from the theory of the identity of pressure deriving from the "two source ideas" that have guided the quoted pure finance essays*, focused in fact on the *mode* and on the *quality* of the imposition.

Indeed, in relation to the models or plans of collective welfare or of the "optimum" recalled earlier, both the logical confirmation of the validity of the well-known theory as its attempted denial, *do not generally represent the necessary premise*. The *quantitative* aspect of the process of redistribution of income or of purchasing power through the use of the tributary factor (collection, destination and relative effects for the benefit of members of the community), as I have said, *prevails*²²⁷ over the *qualitative* aspect of the fiscal element (direct or indirect tax) in the cases examined in which it is presumed to be comprised in the instrument considered suitable and consistent with the objective of achieving a situation of collective maximum welfare or "optimum".

In this way, on the one hand, it is demonstrated that the developments of the Marshallian or Pantaleonian theory have confirmed or extended its validity in the context of the initial premises, or modified premises in the sense to which U. Ricci, Hotelling and Frisch have adhered, the first incidentally and the other two systematically.

However, on the other hand, the models of maximum collective welfare or of "optimum", put forward earlier in an exemplificative and typically meaningful way, without the comparison of qualitative factors, highlight how the fundamental theory – also in the Hotelling–Frisch generalisation – is not necessarily a logical premise for the solution of a problem, set in a different way, of (maximum) collective welfare.

The conclusion that becomes apparent does not diminish or limit the inventiveness of the fundamental theory based on the qualitative juxtaposition of tributary instruments. Indeed, in the context of the initial or expanded premises, the demonstration of the Pantaleoni-type theory or its rebuttal sheds light mainly on the condition of maximum satisfaction or of equilibrium of the perfect hedonist, expressed in the sense of the equality of ophelimities considered or of the equality of relationships between respectively marginal utilities and prices.

However, as has been seen, there are conceptions of maximum welfare or *optimum* that in a logical-instrumental way use the tributary factor, not necessarily configured from a qualitative point of view, but considered from the quantitative point of view. For these models the demonstration of the identity of burden of taxes of different types or form (qualitative element) does not have the value of necessarily primordial uniformity.

VI.

THE "ECONOMIC PRINCIPLE" AND THE INTEGRATION OF DIRECT AND INDIRECT TAXES

Another theoretical problem regarding the relationships between direct and indirect taxes is the following one, put forward by Barone.

According to the *economic* criterion, already known, that I have discussed in the chapter on rational modes of distribution of taxes, in the distribution of the fiscal burden, the system that – given a certain need by the State – is able to achieve this need in the form that least impedes the development of the *average* income is to be preferred. That is to say, in such a way that income grows more than the population, *minimum* income rises and there is a lesser "convergence" of incomes.

²²⁷ In this sense, from another point of view, the tributary factor contributes to linking the general economic equilibrium in the attempts of macrodynamics considered in the essay of E. D'ALBERGO, *Il problema finanziario e le nuove teorie economiche [The financial problem and new economic theories]* ("Giornale degli Economisti" [Economist Journal], March 1939).



Figura 65.

We have seen how the proposition on the distribution of incomes, which links an increase of the average income with an increase in the inequality of incomes, has been corrected. Nevertheless, Barone suggests the following “reforming action” on the part of the legislator, and my observations relate in particular to this action. Let’s consider the graph (Fig. 65) where: 1) incomes are reported on the x-axis; 2) *AC* represents the tax on consumption; 3) *BR* represents the tax on incomes; 4) *AMG* is the “resultant” of the first two and indicates the distribution of collection of the needs of the State from various incomes.

Having made this premise, it is necessary to have a minimum *OA* not affected by tributes on necessary consumptions, and that the minimum *OB* not affected by taxes on income is rather *high*. In that case it will be possible to correct what *AC* retains in terms of *reversed progressivity*. (With the term “reversed progressivity”, as I have said already, we mean that, as the sums spent on individual goods are not taxed proportionally to the extent of individual incomes, the less affluent bear a relatively *higher* burden than wealthier people.)

In an essay²²⁸ I have demonstrated, however, that Barone disregards the effects that the *use* on the part of the State, of fiscal revenues, at the same time exercise on *the economic conditions that taxpayers in receipt of income*, for the classes compared. I have taken account of the fact that the *differentiation* of public expenditure *benefits* the various classes of taxpayers *in different ways*, affecting the extent of *real incomes* and private expenditure (for their substitution in family budgets of social public expenditure), with the particular instrumentality of the State function with regard to events of production and application of the energies of labour.

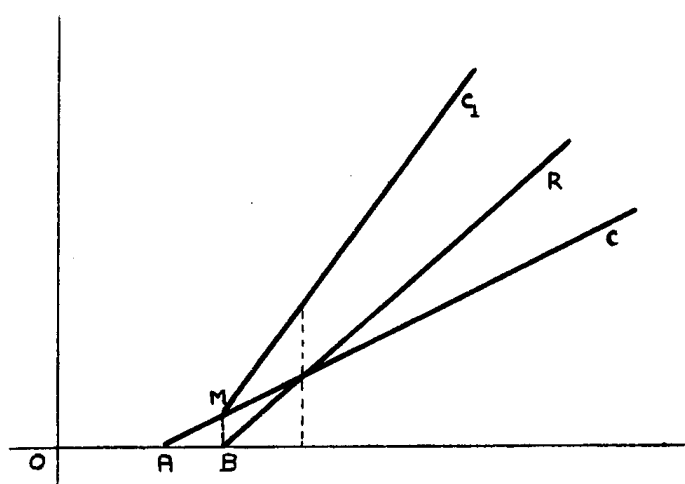
From this derives – by making reference to Barone’s components – 1) that the inclination of *BR*, and therefore the extent of the tax on income, is also a function of the differentiation of public expenditure in favour of the classes of taxpayers who bear its collection; 2) that it is possible to have an income lower than *AO*, *nominal*, as the *minimum* income that it is intended to exempt from taxes on consumption, if the *real incomes*²²⁹ of the classes corresponding to *OA*, because advantaged by public expenditure, can be presumed to be equivalent to those (nominal) ones that are comprised between *OA* and *OB*; 3) that taxes on *income* can be lower than *OB* (disregarding administration issues) as a function of the reasons indicated in point 2) and amply illustrated in the chapter relating to relative contributive capacity; 4) that the minimum nominal *OB* might not be raised, for the same

²²⁸ Titled: *La determinazione della risultante del Barone e i dati del problema finanziario* [The determination of Barone’s “resultant” and data of the financial problem], *Annali dell’Univ. di Ferrara* [Annals of the University of Ferrara], 1937.

²²⁹ In the sense in which I have dealt with them in the essay: *Sulla discriminazione delle spese pubbliche* [About the differentiation of public expenditure], etc. *op. cit.*, and further referred to and clarified in the chapter in this course that deals with *relative contributive capacity*.

reasons; 5) instead of necessarily relying on the inclination of *BR* (influenced also by differential taxes based on relative contributive capacity) for the correction of the inclination of *AC*, it is also possible to use the “manipulation” of public *expenditure* in favour of those who are less affluent, to correct the reversed progressivity of taxes on consumption.

Keeping in mind what precedes, indeed, it is easy to demonstrate that it is possible to achieve a *significant* deviation from the *objective* criterion or from a *class* policy when, by raising the minimum not affected by some of the indirect tributes (*OA*) or the minimum not affected by tributes on income (*OB*), public expenditure is spent for the benefit of those classes with the lower income (*democratic policy*). Similarly, a deviation (*aristocratic policy*) from the “economic principle” can be achieved when, admitting the indicated trends suggested by Barone of *OA* and *OB*, public expenditure is resolved mainly in benefits for the classes with higher incomes.

In conclusion, to be able to pass a judgment on the “economic” distribution of the fiscal burden, it is necessary to consider *simultaneously*, in *theory* and in *practice* (together with other determining circumstances), the pressure of taxes on distinct classes of beneficiaries of income and the effects of public expenditure with regard to them²³⁰. A correct judgment of the limits within which it is possible to make use of direct taxes on income or to indirect taxes on primary or secondary consumption, without impeding the development of the average income, can only be given when the effects of public expenditure are considered: 1) as cause (hypothesis) of *greater income* and *savings*, in turn producing other income, for the classes affected by the tax: 2) or cause of *lesser expenditure* in family budgets, due to a substitution by public expenditure – more or less efficient²³¹ – of a private one.

If these warnings are taken into account, it is possible to have, in theory and in practice, movements of the inclination of the components *AC* and *BR* from the optimum one, complying with Barone’s “economic principle”, which is limited to the collection of two contrasting types of tributes. In consequence, the form of the “resultant” obtained by introducing the public expenditure factor in the sense indicated here can be *different* from that relating to the data considered by Barone. However, the essential compliance of the two inclinations of the “resultant” with the “economic” criterion or objective of the distribution of taxes, which was corrected in Chapter V, paragraph I, and to which reference is made as a *circumstance* that leads to the examination of points of views from which two types of taxes are integrated, having hypothesised the policy of expenditure, can nevertheless correspond to *formal divergence*.

VII.

MULTI-DIRECTIONALITY OF DEMAND AND THE THEORY OF TAXES ON CONSUMPTION

A) In the essay, I have highlighted, in *L'analisi Pareto-Slutsky della domanda e la teoria delle imposte sui consumi [Pareto-Slutsky analysis of demand]*, published in the “Giornale degli Economisti” [Economist Journal], 1949 (celebrating Pareto’s birth centenary), from a rational point of view, the possible effects of the differentiation introduced in the system of taxes on consumption (of “prime necessity” items compared to “luxury” goods) to clarify non-perceived contradictions and illusions of governing bodies and governed people, and to modify or integrate uniformities and theoretical and political judgments in respect of taxes whose range of rates are manipulated by “social objectives” (including exemption, in that clearly equivalent to differences in burdens).

I have proceeded to this:

²³⁰ I carried out a further approximation of the real event, in a purely logical way, with regard to the effective distribution of the fiscal burden (of direct levies compared to indirect ones, and of differentiating levies on consumption) in the essay: *L'analisi Pareto-Slutsky della domanda [The Pareto-Slutsky analysis of demand]*, etc. (Giornale degli Economisti [Economist Journal], 1949), whose content is extensively reported in the following paragraph.

²³¹ See Hobson’s observations at p. 69 of the work quoted in my essay.

I) in *first approximation* and in light of the Pareto–Slutzky analysis of consumer demand;

II) in *second approximation*, considering hypothetically the indirect imposition in the context of the overall financial phenomenon (collection and expenditure not only of the same taxes, but also the redistribution of purchasing power derived, at the same time, from taxes on incomes and estates), and the simultaneous distribution of incomes that overlooks the tributary constraint (in other words, fiscal policy) or is influenced by constraints of social policy (for example, in terms of wages) appropriate to the favouring of the systematic shifting of taxes from shift of taxes from producers to consumers²³². This is so in the spirit and with the objectives *also* of Keynesian full employment, for the transfer of purchasing power to the less affluent who have an overriding “propensity” to consumption of income.

This wider vision is logically necessary. I have already insisted in this “Course” on saying that, without it, it is not legitimate to set out some problems of financial theory, when it is intended to derive from it behavioural norms for hypothetical legislators, as has often been the case with the generalisation of relationships between economic quantities considered in abstract. From Edgeworth to Marshall, from Wicksell to Hobson, from Barone to De Viti, from Stamp to Einaudi, from Borgatta to Black, there is now a clear recognition of the logical legitimacy and the need to widen models to avoid the fallacy and the unilaterality of arguments. This need is absolute when, as for example in the case of Borgatta and Fanno, norms of fiscal policy are suggested.

B) To examine again critically the effects of hypothetical or real provisions regarding the introduction of differential treatment in favour of mass consumption or “popular” goods, having as the objective to compensate for the regressivity of this type of imposition (and its qualification as “anti-social”), it is necessary to use the light shed by what can be said to be an improvement of the *theory of demand*, as was noted in paragraph X of Chapter X.

It is intended to proceed in Pareto’s prolific path, which has been scientifically necessary to highlight, in respect of the developments of financial theory to be added to those of Slutzky, Dominedò, Hicks, Schultz and other Italian and foreign experts and that Demaria has the merit of having critically and systematically spread among Italian academics (in *Principii di logica economica [Principles of economic logic]*, *op. cit.*). I refer to the “multi-directionality” of demand curves, and to its logical explanation, given by the identification of “effects of income” and “substitution effects” in the Italian shifting of concepts particularly in these terms, coined by Dominedò and expressed by Hicks (“*income*” and “*substitution*” effects).

It is necessary to make some clarifications:

a) What is recalled and is applied in term of demand theory is referring to rather typical (average) consumers, representative of groups or homogeneous classes: an approximate hypothesis, that does not evade Dominedò’s criticism on the continuity of tastes, when different classes of beneficiaries of income are considered, which are for brevity empirically differentiated into rich (*R*), average (*A*) and poor (*P*) (DOMINEDÒ: *Quantità economiche oggettive e moventi edonistici [Objective economic quantities and hedonistic motivations]*, “Rendiconti del Seminario Matematico e Fisico di Milano” [Reports of the mathematics and physics seminar of Milan], 1935. See writings of the same author from 1933 to 1943, logically coordinated and indicated in the *Acta Seminarii* of University Bocconi, Milan, 1943).

b) To explain and apply the concept of “effects of income” and “of substitution”, it is necessary to possess the notion of “inferior goods”. Pareto, in establishing a relationship between revenue (income) and demand of (complementary) goods, states that as revenues grow “superior quality replaces inferior quality”. He continues: “therefore, for this reason, demand first grows” (in paragraph 48 he specified “may grow”) “and then wanes, becoming insignificant and even zero”. The examples used to explain the “hierarchy” of goods use the series: polenta – bread – second-quality meat – first-quality meat²³³.

²³² Or employers, generally speaking.

²³³ “Who is very poor eats a lot of polenta, a little bread, very little meat. As wealth increases, he eats bread, second-quality meat and polenta only once in a while; as wealth continues to grow, he eats first-quality meat and other foods of good quality, very little polenta, little bread, and a little higher quality than that which he used before” (*Manuale [Manual]*, Chapter IV, n. 19). Later (no. 51) he generalises with the uniformity: “as income

After having made a reference to the case of margarine, Hicks²³⁴ states that “most of poorer-quality goods offered are, in this sense, *inferior goods*”. In illustrating the effect of revenue, Demaria compares natural silk with synthetic silk²³⁵. The same Knight considers bread as *inferior goods* compared to meat. Other numerous exemplificative comparisons can clearly be considered. We return to Giffen’s paradox, which Knight considered “spurious” and which has instead come back into favour and consideration, judging from the frequency of specifications and illustrations that it induces among academics. The paradox is of interest in these pages, *not in the sense* in which G. J. Stigler identified in Marshall’s and Edgeworth’s works²³⁶, (that is, *in the sense* of an increase in consumption, for example, of bread, as its price *increases*, as it is considered to be a product less expensive than meat and more refined, flour-based products, whose consumption would decrease), *but in the opposite sense*. In relation to this I will make reference to a more recent debate between Stigler and A. R. Prest²³⁷, which has the merit of supplying to the reader the text by Giffen who, among other things, states: people consume smaller quantities of cereals because, as income increase, they consume more meat to such an extent that it replaces cereals, whose price decrease. Prest, however, who recalls this, also quotes statistical surveys that, from his debatable point of view, exclude the admissibility of a demand curve positively inclined for a *section* of the community. In his reply, Stigler documents how Giffen had refused to confirm his paradox (in 1894) that should be ascribed, therefore, to Marshall. [However, it is a completely different reason which means that Marshall, as I observe later, can be considered to be not only in the logical order of Giffen’s view, but also in that of Pareto–Slutzky.]

The spirit of this empirical uniformity, believed not to be adequately supported by statistics, nevertheless preserves a strong similarity to reality, which is to be kept in mind in this type of argument.

Slutzky’s terminology is different, in the Italian version – not very well chosen – in terms of *indispensable goods*, which would be Pareto’s “superior” goods (*Manuel [Manual]*, p. 573) and *dispensable goods*, which can be made to correspond to the “inferior” ones in Pareto’s terms. In Pareto’s wake, the Russian economist²³⁸ expresses the known empirical uniformity (after having correlated an increase in consumption of indispensable goods with the *increase of income* and a relative decrease in that of dispensable goods, on the other, in the following sense: “As income increases, a poor family will consume more meat, more sugar and more tea; less bread and fewer potatoes.”

This helps in the realisation of the juxtaposition between “superior” or “inferior” goods. However, more will be said later about the correlation between variations of monetary income.

C) In the meantime, to interpret the range of real cases and the hypothetical or abstract one of interest, consisting of the *exemption* granted to “inferior” goods or to the reduction of rates in the hypothesis of specific taxes in the context of the general tax on consumption (of all goods and services), it is necessary to return to Slutzky (who has reworked Pareto’s idea) to take into account the relationship between the *price variation* of goods and the consumed or demanded *quantity*.

grows, so superior quality takes the place of inferior lower quality, therefore for this the demand first goes up as income grows and then wanes, up to becoming insignificant and even zero”. See *Appendice [Appendix]*, paragraph 52 of the *Manuel [Manual]*, for the analytical expressions.

²³⁴ *Capital and value*, 1939 Edition, p. 28.

²³⁵ (*Principii generali di logica economica [General principles of economic logic]*, pp. 272-73.

²³⁶ “The Journal of political economy”, April 1947. In this sense there is a confirmation of this in the Italian experience (*Curva di domanda di consumi alimentari [Demand curve for food consumption]*) by Francesco Brambilla, in an investigation promoted by the Institute of Economic Studies [Istituto Studi Economici (I.S.E.)], 1948. Resulting from this is: *a*) the increase in the price of flour ... causes an increase in consumption, rather than a decrease; *b*) the consumption of flour decreases when economic conditions improve. This second empirical uniformity could be interpreted in the *second* meaning of the paradox (note Stigler’s thinking and that of others in the text).

²³⁷ “The Journal of political economy”, February 1948, with a note by Prest and a response by Stigler.

²³⁸ In “Economist Journal”, July 1915, under the title of: *Sulla teoria del bilancio del consumatore [About the consumer equilibrium theory]*.

a) The demand of a relatively *indispensable* item is necessarily always “normal”: that is to say, it decreases if the price increases and increases if the price decreases.

b) The demand for a relatively “dispensable” item can in some cases be “abnormal”: that is to say, it increases when the price increases and decreases when its prices decreases.

Because both the exemption from the tax, at the time in which it is conceded, and the differentiation in favour of inferior goods (such as some staple foods in the budget of more numerous classes of people with lower incomes), can be considered *equivalent to price decreases* in the policy of taxation of consumption, the values of the derivative can be expressed as follows:

$$\frac{\partial x_i}{\partial p_i} < 0 \text{ ----- } \frac{\partial x_j}{\partial p_j} > 0$$

(i = “indispensable” goods)- - (j = “dispensable” goods)

To focus – as Boulding says – on the “vivid geometrical method that gives shape to the form of relationships between quantities”, of which, in the specific case, Slutsky has defined the above property, I will use Hicks’ representation²³⁹ transferring in a single adapted or, here, more complicated graph the trends (curves) that he had represented separately. The curves he used to highlight the “effect of income” and that of “substitution” due to a variation (in the hypothesis: price reduction) are not indifference curves²⁴⁰ but curves of marginal valuation of goods in terms of money, such as Marshallian ones, as *marginal valuation* is the price that separates the higher prices, at which the subject does not purchase, from the low ones, at which he decides to make the purchase. Hicks intended to highlight the “effects of income” by eliminating every reference to measurable units, but presuming that, for small price variations, curves of marginal valuation share the same properties of indifference curves, and are in fact preferable to them for partial analyses.

Let’s consider a hedonist with a given income, and let’s presume the prices of $N - I$ (consumption) goods be known. Let’s indicate the prices on the y-axis and the quantities on the x-axis, for the n th item. Let AV be the “curve of marginal valuation”.

Case a): let’s presume a decrease in price from OH to Oh . If the “income effect” did not apply, and only that of substitution did, known traditionally on the basis of the law of univocal demand, the subject would purchase the quantity $hQ > HP$. However, in the logical model of Pareto–Slutsky–Hicks *et al.*, the decrease in price influences the demand in two ways: 1) by improving the condition of the hedonist, increasing real income “as if” the monetary income had increased; 2) by suggesting a substitution of goods whose price has remained constant with with other goods whose price has decreased. This is the “substitution effect”, which is dominant and positive in the case in which the goods whose price has decreased are not “inferior”. In the hypothetical case it acts in the same way as the “income effect”, in function of which the curve of marginal valuation is raised, becoming Av .

The quantity purchased will be equal to $hp > hQ$, the quantity Qp being due to the “income effect” and the quantity $Q'Q$ being related to the “substitution effect” for the reduction in price from OH to Oh .

Case b), which is of interest to us in this first approach to the tributary problem (differentiation or personalisation of the tax on consumption to make it less “anti-social”), is the following, that is to say, the reverse.

Graphically, for inferior goods, given Slutsky’s relationship that (*case b*) is expressed by the positive inequality, in terms of value, of the derivative for “dispensable” goods, made equivalent to “inferior” goods, there will be a shift in the sense of Av' , that is to say, to the left of the initial curve AV (of marginal valuation). The demand curve will also pass through points P and p' , at first sight

²³⁹ *The four consumer’s surpluses*, in “The Review of economic studies”, n. I, 1943.

²⁴⁰ E. H. Knight considers as a “real” indifference curve the one traced under the condition that the subject actually purchases each successive small unit of goods (x) indicated on the x-axis at the maximum price he is prepared to pay, after having paid the preceding units in these terms. Hicks reasons essentially in this logical order and her curves can therefore be considered to be equivalent to those adopted by Knight.

contrasting the traditional theory of demand, essentially based on the “substitution effect” (or on its implicit *prevailing*).

However, it is the particular “effect of income” that needs to be noted and that is rich in meaning for financial theory (and for fiscal policy, in the limits in which a deductive argument is capable of being generalised and is confirmed by statistical verifications). In the geometrical example, the hedonist is induced to purchase a lesser quantity of the “inferior” item when its price is reduced from OH to Oh : the purchased quantity is reduced from hQ to hp' . The consumer who enjoys an increased purchasing power will direct his attention toward “superior” consumption that will replace in part that of the goods classified as “inferior”.



Figura 66.

Of course, the hypothesis of a contraction of demand of the “inferior” item, at $hQ' = HP$, that is to say, the quantity that would have been purchased at the initial price OH or even at hp'' if the curve of marginal valuation hypothetically becomes Av'' , is not implausible. In any case, it is supported not only by the affirmations of Giffen and of those who have shared his opinion, but by the vision, normally founded on facts, suggested by Marshall, of whom can be said, “in a nutshell”, to have independently expressed the law of “multi-directionality” of demand, even without the assistance of the conceptual expression of indifference curves but in the terms I have quoted here.

Indeed, in addition to confirming the effect of substitution, the following consideration, presented in terms of obvious uniformities, may have another meaning (“effect of income”). “Human desires and needs are innumerable and very varied, but they are generally limited and susceptible to being satisfied. It is true that the uncivilised man does not have many more than the brute animal, but each step in his rising progress increases the variety of his needs and at the same time the variety of his methods to satisfy them. He does not simply desire greater *quantities* of the things he is used to consuming, but better *quality* (Marshall’s italics); he desires better selected things, and things that will satisfy the new needs he will develop” (which is equivalent to saying, I believe, new goods) (*Principii di Economia [Economy principles]*, paragraph. 79, Volume III, chapter II).

So, as far as “rising progress” goes, in the field of material welfare, we must admit that to be due to an increase in income or in purchasing power. For this reason it is not necessary to proceed to an arbitrary interpretation of Marshall’s thinking, because after expanding the quoted concept in the

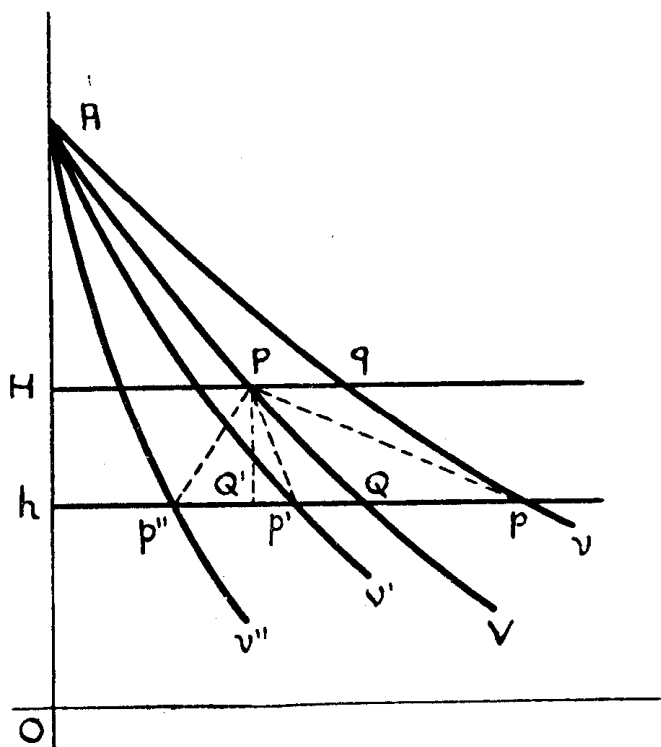
second paragraph, in the third one he explicitly states: “As someone’s wealth increase, his food and his drinks become more varied and more expensive”, etc. Therefore, can we not take this viewpoint that precedes the analysis of demand in the logical order of Pareto–Slutzky and others, even if Marshall did not use indifference curves? And are we entitled to believe the “income effect” expressed in the substance of the logical concept, over and above the secondary questions of terminology? This interpretation of Marshall’s thinking, which I believe to be “generous” for the conceptual equivalences that I have established, others might believe to be natural or logical. This is so even if Marshall limits himself to expressing, without further deductions, this mode of variation of demand of goods with variation of income, as he then continues to argue normally in the hypothesis of constancy of income.

D) This (income) “effect” is to be considered, with regard to the influence that its introduction exercises on the propositions derived in terms of incidence of indirect taxes, together with those that, in the same sense and in an “additional” manner, determine the introduction of hypothetical variations in the monetary income of some classes (for example, *P* and *M*) for the processes of redistributions to which we refer later.

However, it is opportune, for now, to isolate the influence of the “income effect”: 1) for the hypothetical exemption, decided upon at a given time, from particular taxes on consumption, or from general taxes, of goods considered to be “necessary” (for example, the French *impôt sur le chiffre d'affaires*, the Italian taxes on incomes, etc.); 2) in the hypothesis, generally indicated above, of differentiation “in favour” of such consumptions, with the simultaneous introduction of a differential rate “against” goods that we could consider here, in relative terms, as “superior goods”.

It is clear that we proceed by approximations, presuming, among other things, that there is a certain homogeneity and continuity in tastes in the typical categories of beneficiaries of income (poor, middle and rich classes, respectively indicated with the initials already indicated). We presume a certain homogeneity in the quantity of “inferior” or “superior goods” or in the classes of goods (services and products) on which income can be spent.

It is possible to conceive observations, in the sense that they result from the following paragraphs, for the fiscal reason considered here (exemptions, differentiation or personalisation of general taxes on consumptions). We intend the cause to be placed in a logical relationship with the action of the “income effect”, which is clearly to be presumed to be widespread, given the hierarchies of goods that exist, depending on the ideal markets or countries with different average incomes, and allow the identification of goods that are relatively “inferior goods”:

a) A tendential contraction, in a first approximation, of the demand of “inferior” or necessary goods or goods for “popular” consumption (to use a sociological expression), *contrary* to the *presumption* and the *expectation* of the legislator, who had intended consumptions – to use the current terms adopted by Neumark – having “social importance” or being “physiologically” more important to be *extended*.

The “income effect” (considering this category of rather homogeneous goods, “inferior” with respect to luxury goods, or even within certain limits considering the “inferior” quality of the same goods in contrast with the “superior” or refined quality normally required by beneficiaries of larger incomes) determines contradictions and illusions with regard to legislative provisions differentiating in favour of “inferior” goods in the typical forms hypothesised.

If it is intended to pursue “social” objectives (extension of *specific* types of consumption) correlated to given classes of beneficiaries of income, the implementation of such objectives through differentiation (reduction of some rates while maintaining others or increasing them on goods that are relatively more luxurious) or personalisation of the indirect imposition, must be carefully thought out. Indeed, in this first approximation, it is possible to perceive “income effects” that shift the demand of the classes to be advantaged towards taxed goods, thanks to the contraction of the demand for goods that, instead, the legislator would have liked to extend. This result is due to the artificial creation of differences between prices of categories of goods “hierarchically” in contrast to each other. Indeed, the “income effect” appears to be stimulated beyond the level it would have reached in the absence of the manipulation of the tributary constraint, in the free process of price setting.

For now, let's review Fanno's vision²⁴¹, who, as has been seen, dealing with succedaneous goods in relation to a luxury (main) item subject to tax, thought that the fiscal exemption granted to "general consumption" goods "did not impede their price being increased". I recall that he continued by saying: "From this derives a second consequence, that is to say, that the presumption to prevent the effects of a strong tributary pressure on the population of the lower classes by exempting general consumption goods to concentrate the overall fiscal burden on luxury goods is in part an illusion. The price increase in the former is certainly by and large lower than that of the latter, and it is as much lower as the mass of exempt general consumption goods is conspicuous in comparison to that of the taxed luxury goods. In this way, through the play of the relationships between the prices of succedaneous goods, the legislator's intentions remain in part frustrated.

What precedes entitles us to believe that the good intentions (to prevent the lower classes from suffering the effects of a strong tributary burden) are frustrated in the context of our imposition, for reasons that are different from the ones that Fanno takes into account, thinking in terms of univocity in the mode of variation of demand when prices decreased (due to fiscal exemption). Indeed, it is not only the transfer of demand (presumed to be non-rigid) of taxed luxury goods to those of general consumption (not taxed) that causes the increase in price in the latter, determining *indirect fiscal pressure* (on exempt "inferior" goods) of the imposition on luxury goods. However, precisely at the time it is conceded, as it is equivalent to a proportional increase in real income, fiscal exemption *drives* consumers from lower income classes towards the demand of superior goods (relatively luxurious) that the legislator has taxed, due to the illustrated "income effect". The contrast between the objectives and effects of the hypothetical *spirit of the law* consists in the fact that the legislator, by exempting general consumption goods (which we believe to be "inferior"), that is to say, in an attempt to compensate for the errors of the past (regressive taxation), believes that the substitution effect will increase the demand or the consumption of those goods that are normally purchased by the lower classes. Conversely, the "favourable" treatment can result in part in a *voluntary* submission of the classes favoured by the differentiating indirect imposition precisely because of the *preferences* that the improvement of their situation or the increase in their purchasing power (due to the tributary exemption) stimulates in consumers for "superior" goods, which the legislator had decided to tax exclusively or tax more extensively.

b) Furthermore, in this way, so-called consumer's "surpluses" are artificially created in classes *M* and *P*, the classes that are most likely intended to be protected from the differential tributary burden by those who, for example, Griziotti recently²⁴², suggested as rational (and not only in the sense of sociality) tributary *standard ways to perform*, in the sense of the *absorption* (by real taxes on consumption of luxury or on "less necessary" goods) precisely of the "surpluses" of the type normally presumed to be correlated to budgets of beneficiaries of income in class *R* and part of class *M*.

Neumark, to whom I refer in terms of updating the fiscal problem (synthesis of dominant ideas in 1948), *compares*: (I) primary necessity goods (such as sugar, meat, salt); (II) economically relatively "superior" consumption goods, and not in the physiological sense [such as alcoholic drinks, tobacco, wine (for people in Northern Europe), beer, shows (cinema, etc.), the use of petrol for travel, etc.] which are "nowadays of great importance to the masses". He argues by saying that the *elasticity* of demand of these goods and services (II) is inferior to that of goods physiologically more important (I), most likely and implicitly instigating a correlation between the variations of monetary income and approaches to consumption.

If, however, for the purpose of extending consumption of "socially more important goods", taxes on series (I) of consumptions of primary necessity and of *some* of those (II) that the "masses" appear to prefer (even if not objectively or physiologically "necessary") are abolished, as he suggests, interpreting wider opinion streams, the "income effect" (real increase of purchasing power) partially

²⁴¹ *Contributo alla teoria dei beni succedanei [Contribution to the theory of replacement goods]* (in the "Annali di economia" [Economy Annals] of Bocconi Università, 1927, pp. 398-99), introduced in Chapter XI, paragraph X-3.

²⁴² In volume V (*Finanza [Finance]*), *Appendix* to the Relazione della Commissione economica Ministero per la Costituente [Report of the Economic Commission for the Constituent Ministry].

stimulates demand towards relatively “superior” goods that are generally intended to be the subject of real taxation, by extending the *according to value* system. The creation of consumer “surpluses” would lead, at least in part, to their absorption according to the vision close to the likely real one typically identified in these observations. There is a confirmation, from this point of view, of the probability of *contradictions* caused by the disregard of the multi-directionality of demand, which is considered in a particular sense (*income effect* for “inferior” goods) to illustrate a tributary phenomenon.

E) If we introduce the concepts of complementarity and substitution of goods, always remaining within the hypothesis of “hail tax”, we have two cases, which are illustrated below in points I) and II).

I) a) In the case of *complementarity* (which I do not differentiate in term of “high” and “average” as Hicks does, as these are degrees of variation that do not modify the fundamental meaning), if we consider the differentiation “in favour” of relatively “inferior” goods because the “income effect” increases demand of complementary goods in the higher series, the link of dependence between two categories ends up modified by the incidence of the tax on superior goods, in part charged to categories *M* and *P*.

This would lead to the integration of propositions, important in the context of the hypotheses from which they are derived, such as those, for example, of Borgatta or Edgeworth, which have been discussed in Chapter X, paragraph X-A).

b) In fact, reasoning on perfectly complementary goods, Borgatta, as was seen, believes it possible that a tax on one of the complementary goods reduces the consumption of the taxed item, but simultaneously also that of the other product, as the subject chooses a combination with a lower index and with loss of utility (due to the reduction of the consumer’s surplus)²⁴³.

Let’s introduce now the hypothesis that at the same time we move from a regime of equal taxation of goods having a certain degree of complementarity (which in any case *is not to be intended as perfect and absolute*) to a reduction in rates or exemption for a product *B* and an increase for the other, *A*. If *B* is “inferior” and *A* is “superior”, there should *not* be, in a sensitive and tendential contraction of demand of the item differently taxed (completely superior “against which we discriminate”) to the extent anticipated in traditional theory. This is so because the *contraction* of demand of item *B* would become a *determinant* of the greater demand of item *A*, rather than being the *effect* of the reduction in demand of item *A* due to its differential or exclusive taxation (superior), as has been stated in the visions of authors who have not taken into account, even in the context of complementarity, the hierarchy of goods and its correlated “effect of income”. The new combination of consumptions would not be characterised by the loss of utility and in any case it would not be so to the extent anticipated by other authors for the contraction of consumption of one item *B* taxed more or less.

c) As was said at the time, Edgeworth starts from the relationship of complementarity to reach the conclusion: “the tax on one of the two complementary goods will increase the price of the one affected by the tax and will reduce the price of the other which is not”²⁴⁴. Later he continues: “It is possible to conceive that this latter effect is so much greater than the first (increase of price of the affected goods) that ultimately it results in a gain for consumers” (most likely in terms of increase of income of the same). Let’s presume that the diversity of fiscal treatment is the result of arguments and decisions on the part of the legislator on the type of differentiation or personalisation of taxes, hypothesised previously existing in a uniform manner. In this case the “consumer’s gain”, if the less-taxed or exempt item (*B*) is “inferior”, does not consist in the purchase of it at a lower price (or essentially in greater quantities), but in the possibility of shifting demand toward the superior item *A*, even if taxed in a differential way. In this way the typical subject reaches a new combination which includes a greater quantity of the item exclusively or differently taxed.

²⁴³ *La rendita del consumatore e le sue applicazioni finanziarie*, [Consumer’s surplus and its financial applications], in “Giornale degli Economisti” [Economist Journal], July 1921.

²⁴⁴ *Teoria pura dell’imposta* [Pure theory of taxation], in “Bibl. dell’Econ.” [Economist Bibliography], Vol. XVI, p. 292.

II) *a)* If we make the hypothesis of *replacement* or substitution generally, contrasting goods mainly in the sense of *quality* as well as by their different nature, reconciling tributary provisions “in favour” of “inferior” goods (less costly and more common or less valuable), the effect of substitution does not work in a strong way, such as would be expected from the unidirectionality of demand, presumed to be acting exclusively. However, there will be contraction of this consumption (“inferior” goods) to direct demand towards “finer” substitutions or towards the main item in greater measure. Relatively “poorer” consumers or those from the classes indicated with *P* and *M* (in part) would tend towards “finer and more expensive surrogates” or towards corresponding main goods, spontaneously and *without sacrifice*. Unlike what had been anticipated (logically *in the context of his hypotheses*) by Borgatta, in his subtle analysis (in consequence, precisely, of the taxation of the less expensive item), this would no longer be when – contrary to the normal supposition of legislators – a reduction in the tax or an exemption acted in favour of less expensive goods. Indeed, the consumers’ approach (normally for less expensive or “inferior goods”) would lead them to the consumption of “finer and more expensive surrogates”, compatibly with an increase in ophelimity or of subjective utility (in part, totally or physiologically objective), even when submitting to differentiating taxes “against” finer goods affected, that is to say, to proportionally superior taxes.

The uniformity formulated by Borgatta, therefore, that a tax (*introduced or increased*) on a “less expensive” item, which here I will consider to be “inferior” (most likely without any discretion), in the sense known by now, would lead to a reduction in its consumption, as the consumer would more or less move towards the finer and more expensive (“superior”) item, needs to be considered also in the *opposite hypothesis*. That is to say, the case of a *reduction* or *abolition* of the tax on “inferior” goods: this would be a fiscal provision which would be followed by the movement of consumption towards superior goods, including finer and more expensive surrogates, compatibly with an increase in satisfaction for the hedonist-consumers considered.

b) Generally, the transfer of demand on the part of beneficiaries of income (*R*), consumers of the main or luxury item taxed, towards “inferior” or succedaneous goods (downward flow) is set against a transfer in the inverse sense, due to the exemption (upward flow), at the time it is conceded, and the subsequent advantage for classes *M* and *P* that benefit from this, who, considering this as an increase in real income, aim to acquire “superior” goods, even if taxed. From this derive two differential consequences:

- 1) the decrease in grade of elasticity of demand of taxed goods;
- 2) the increase in the price of non-taxed succedaneous goods (or exempted) *inferior* to those hypothesised by Fanno. The illustrious academic, reasoning on the basis of only the effect of substitution, added to the demand, presumed constant, of goods here defined as “inferior” on the part of “humble” classes (that at least in part should correspond with the classes *M* and *P* hypothesised here), or increasing (in the mind of the legislator) due to the effect of the conceded exemption, the demand deriving from the migration of consumers from class *R* from the taxed luxury goods market towards that of the exempted inferior goods.

The extent of the addends, on the basis of what has been said, ends up therefore being *inferior* to that anticipated by Fanno with regard to the demand of exempted goods. The fiscal revenue could be relatively *greater* than that which could be anticipated on the basis of arguments, albeit shrewd and coherent of the quoted author, developed in the context of more limited hypotheses on consumer demand.

From this derives the possibility of non-taxation of general consumption goods at the same time as the taxation of main or luxury goods, *given* a prefixed fiscal revenue that a State might anticipate. This is so precisely because, even if there is a movement of demand towards inferior goods on the part of class *R* (that the legislator intended to be affected by taxation by law or formally, through programmatic or pre-judicial declarations), within the limits in which the effect of the fiscal exemption in favour of *M* and *P* is greater than the variation of price (and of the individual expenditure) of “inferior” goods due to the presumed greater demand of general consumption goods on the part of *R*, the differential “income effect” makes it possible for *M* and *P* to purchase taxed “superior” goods. From this derives the assurance of *given* fiscal revenue drawn *only* from the main

goods, without the necessary taxation of “inferior” ones, which Fanno suggested, from his point of view.

The exemption of general consumption goods could be the factor determining, in fact, “the greater taxable matter” of *A* (luxury item) whose creation Fanno suggested with the simultaneous taxation of succedaneous or relatively “inferior” goods. The disruption of the market, which would be inevitable on the basis of this presumed multi-directionality of demand (because of the “effect of income”), would give way to a redistribution of consumptions: this would, however, be implemented without any damaging effect, but compatibly with the budgets discussed by Giffen, Marshall and, specifically and according to the logical note, Pareto, Slutsky and the other quoted authors.

All this is stated in a first approximation, because the criticisms and the suggestions of “*the standard ways to perform*” in this matter can be put forward while observing reality, when the policy of expenditure and of the redistribution of income and tributes in the *residual* tributary system, from which of course we must draw to concede the exemption, is simultaneously considered, as a hypothesis that is introduced before that of the modification of the existing economic equilibrium, precisely by means of the exemption of class consumptions (*M* in part and *P*).

F) I recall at this point what had been put forward when identifying the possibility of proceeding to a *second approximation*, at point *A*) of this paragraph.

I have already underlined the logical need for this approximation which was, in the specific case of the consideration of the tendential incidence of indirect taxes on consumption, Borgatta’s intuition, for example, when he expressed the following statements, which are correlated, within certain limits: *a)* “The tax changes the distribution of income among the various groups of consumptions; therefore, to evaluate exactly its effects, it would be necessary to know the new system of equations in which this translates and the new system of demand curves”; *b)* “the revenue procured by the tax is spent by ways that in turn influence the economic equilibrium”.

That is to say, it is not a matter of observing the well-known *hiatus* that exists between the theoretical model and the complex historical reality, but in particular it is necessary to highlight the *inadequate formulation of hypotheses* when deductive processes reach conclusions which have the indirect objective or the effect of focusing on the *legislator’s behaviour*, or in any case the objective of shedding light on the rational content of positive laws for the distribution of indirect tributes on consumptions.

Indeed, the most probable, hypothetical trend of demand, even if considered by typical groups of consumers, of the rich (*R*), middle (*M*) or poor (*P*) classes, is not known if no account is taken of the logical necessity felt by others – *but not followed in the theoretical developments* – of the destination of the revenue of the same imposition on consumption.

This is not all. As this is a matter of comparison of direct and indirect, income and consumption taxes, because of their relationship with overall incomes (proportionality, regressivity or progressivity), or from the point of view of the obliteration of consumer surpluses or the reduction of the combination of goods in models including the hedonist’s equilibrium, represented through indifference curves, etc., it is also necessary to take into account the great trends in the redistribution of the revenue of all or of the representative types of tributes. The complex close examination must include the effects of De Viti De Marco’s²⁴⁵ “social benefits”, my “protection incomes”²⁴⁶, Pigou’s “transfer expenditure”, Hicks’ “distributional effects”, “the expenditure of the tax proceeds” systematically taken into account by Black, etc., to recall some cases of the rational introduction of this factor. It is possible to talk about “tax proceeds” in the tributary system by making reference to the *entire* system. I mentioned in my quoted essay²⁴⁷ (see paragraph V of this chapter) collections of taxes on more affluent incomes and on successions, to be destined in favour of those who are less affluent, in Pigou’s and Hotelling’s approach, and Pareto’s and De Finetti’s hypotheses for the reimbursement of “constant” expenditure to producers, for the benefit of the community, comprised

²⁴⁵ *Principii [Principles]*, *op. cit.*, paragraph 98.

²⁴⁶ See: E. D’ALBERGO, *Discriminazione delle spese pubbliche indivisibili ed elisione dalle “rendite di protezione” [Differentiation of indivisible public expenditure and its elision from “protection incomes”]*, *op. cit.*

²⁴⁷ E. D’ALBERGO - *Sviluppi di un teorema finanziario ecc. [Development of a financial theory, etc.]*, *op. cit.*

mainly of beneficiaries of lower incomes, *P* and *M*, by giving them the possibility of purchasing goods at costs equal to marginal costs and, therefore, of maximum welfare.

The effect of the demand of some of the goods analysed cannot be disregarded, when modifications in the monetary incomes in favour of classes *M* and *P* are determined. We talk of increments in pensions, wages, salaries, family benefits, premiums, or significant increases in real incomes, due to the substitution of public expenditure for individual ones in the field of medical assistance, and of political prices for goods and services which include costs charged to higher levels of class *M* and to class *R*. Generally speaking, Black takes into consideration not only the *quantitative* variations of consumptions (demand) determined by the differentiation in public expenditure, but also of *qualitative* variations, in the sense of the progress of degree (or quality) of food consumptions, homes, etc., that, for example, classes *P* and in part class *M* are allowed to consume, on the basis of the distribution of the revenue from tributes affecting primarily members of class *R* and in part of class *M*.

It is clear that monetary and equivalent variations of incomes, exemplified here, modify the conclusions of financial theory with regard to the subject of incidence of taxes on consumptions.

For them to be, at point A), in *second approximation*, we made reference to the introduction of the constraint represented by the policy on wages. We have reached, on the basis of the hypothesis of automatic increase of salaries as a function of cost of living (including the burden of tributes on goods), an optimistic expression, in the sense that the regressivity of individual indirect taxes on consumptions would not occur. These are “paid by employers” through the game of “wage indexation systems” (in Italy, contingency indemnity) or similar forms of adjustment of work remunerations to variations in the cost of living, also influenced by increments of taxes on goods (in particular those *according to value*).

It must be observed: *a*) that these adjustments do not take place immediately; *b*) that they do not take place in an equal way, that is to say, for “workers” of all categories as real examples can demonstrate, determining the regressivity of taxes and, generally speaking, a decrease in real incomes for classes *M* and *P*; *c*) that not all goods and services affected by tributes are included, or are included with equal weighting, in the empirical calculation of the cost of living; *d*) that the incidence of the tax on employers is not indefinite, because the total income from which it is possible to draw in order to increase work incomes with the variation of the cost of living (among other things, with the variation of taxes on consumptions) is not unlimited and does not vary for all entrepreneurs and employers generally, in proportion with the increase of the cost of living. It is for this reason that, even when restricting the quotes of compensation that in the context of distribution are apportioned to capital and to the entrepreneur, the adjustment of the wage–cost-of-living ratio takes place *uniformly*, reducing the portion of total income destined to compensate “workers” - beneficiaries of income, in a discriminate way according to returns (productivity). From this derives the levelling (or “flattening”) that is observed in some countries²⁴⁸. In the limits in which there is no wage “appreciation” (re-establishment of the relationship between remuneration and performance), the *indirect imposition* acts – as a factor of increase of the cost of living – in a *regressive* sense for numerous categories of people in receipt of work incomes, which account for a growing proportion of social income.

In addition to being regressive in the hypothesis of “hail taxation” for beneficiaries of work incomes, individual taxes on consumptions, for the part that automatically affects employers, become equivalent to a direct imposition: however, not on profits or revenues from industry, commerce, agriculture, etc., but on a portion of the cost of production (wages), which is not statistically in direct relation with the variation of the net income for employers. There is therefore an inequality in the taxation of enterprises, therefore, at parity of respective net incomes.

All this tells us that the *optimism* of those who believe that taxes on consumptions are devoid of objectionable effects, because collected from employers, is not logically admissible. However, it is necessary to take this into account, in this essay, especially if the “flattening” of wages benefits class

²⁴⁸ If all beneficiaries of income are compensated with quotes proportional to the variation of the cost of living and in the absence of adequate differentiation for productivity, we would reach a situation of actuation or expression of a modern “iron law” of gravitation towards the “minimum vital income”.

P and part of class M , whose modification of demand of goods subject to taxation needs to be considered, when monetary income varies simultaneously.

G) The influence of the variation of monetary income (or in equivalent real terms) in this second approximation *is not* examined in relation to the hypothesis of a *decrease of price* of an item or a typical group of goods. We have previously mentioned the *additional* effects of a variation of the nominal or monetary income when the reduction of this price takes place also because of a reduction in the tributary burden. I am referring to the exemption or differentiated taxation in favour of goods or assets that historically and abstractly represent classes or groups hierarchically “inferior” in the budget of typical consumers. Indeed, it is easy to associate in a *simultaneous* consideration the cases of increases respectively in monetary and real incomes: this latter, due to the decrease in the price of goods and, in our case, to fiscal exemption or differentiation of the rate of taxes on consumption. The conclusions expressed earlier are therefore modified, especially in terms of “degree”.

However, the developments of the theory of demand, in the hypothesis of an *increase in prices* of goods or items, placed in relationship with an *increase* of the monetary income (or equivalent in real terms) for the redistribution of flows of wealth of the type hypothesised, are now of interest to us.

In this *second approximation* it is possible to argue: 1) also about the hypothesis of the rates that affect goods uniformly or proportionally (and without the differentiations contemplated earlier); 2) and also the particular or special taxes on consumptions not coordinated in a rational system, and therefore normally regressive for many beneficiaries of income, if considered separately from the increasing *hypothetical* variation of the monetary income or equivalent and, generally, in the hypotheses of “*hail taxation*”.

Let's therefore isolate, for ease of theoretical illustration, the case of the relationship between variation of income and modification of demand, according to the Pareto–Slutzky vision. Adopting the symbolic expression of this latter author, we have:

$$\frac{\partial x_i}{\partial s} > 0 ; \dots \frac{\partial x_j}{\partial s} > 0$$

That is to say: *a*) for indispensable goods (symbol i) or “superior” goods, an increase in consumption corresponds to an increase in income (s); *b*) for “dispensable” “inferior” goods (symbol j), consumption decreases as income increases. In both cases consumption is made equal to demand, a concept that is more abstract and less corresponding to the actual phenomenon. Hicks denominates more exactly the *income-consumption curve* as that of demand linked to the *variation of income*.

To translate the sense of the variation indicated by the analytical symbols, in other words, the inequalities expressed here, into a geometrical expression using the indifference curves (to take account of the income variable that influences the demand and disregarding the Marshallian hypothesis of the constancy of the utility of money), we obtain the graph in Fig. 67.

The consumption curve S_{yy}' , which approaches the y -axis (on which we measure monetary income) as income increases, highlights the reduction in “inferior” goods (which must be read as quantities represented on the abscissa), therefore with a pre-eminence of income effect.

[The trend of $SS'S''$ relates to the demand of “superior” goods (in turn, in this hypothesis, represented on the x -axis): as income increases from OR to OR'' , their demand increases, with a prevalence of the “substitution effect” with regards to them.]

Even presuming that the price is increased by a tax on consumption that has as its object mainly “inferior” goods in a relative sense (or “dispensable” according to Slutzky), a simultaneous increase in monetary income can have the effect (also in this hypothesis with the prevalence of *income-effect*) of reducing the consumption of taxed goods belonging to the category of “inferior” goods, so reversing residual demand towards other goods (“superior”).

Of course we start from the case, which is the *limit*, in which there is an increase in income (ds) of exactly the same extent as $x_j dp_j$, which Slutzky calls “apparent deficit” in the consumer budget, due, in fact, to the increase dp in the price of goods x_j . In other words, the increase in income (ds) can correspond to that which this author defined as the “*price variation*”.



Figura 67.

Even though he has the possibility of conserving his equilibrium unchanged, the individual will not continue to consider it preferable to every other one. However, in the case of “compensated variation” (in relation to which Dominedò and Hicks in particular have analysed the influence on demand), taking the example of the increase in the price of bread, if wages increase only to an extent equal to that of the “apparent deficit”, the demand of wage earners will not remain at the original level: in fact it will decrease. Slutsky’s uniformity is justified by the previous expression of this author: given the compensated variation of price, there will be some residual variations of demand.

I) We can sense what might be the direction of demand when this increment dp_i is due to a variation of the tributary factor (tax on goods) and the variation ds is due to a destination of the revenue of the same tax in favour *mainly* of classes *M* and *P*. II) However, the real phenomenon legitimises, according to what precedes, the hypothesis in which at least for some (in all or in part of *M* and in all *P*) the modification of income is not only “compensating”, but leaves a surplus in the budget of the named groups, with an incidence (deficit) charged in part to group *M* and to group *R*. In this way for the first there is a net “benefit”, essentially expressed by $ds > x_i p_i$.

It is this second hypothesis in particular that authorises the *review of the prevailing conclusions of financial theory with regard to the incidence of indirect taxes on consumptions*.

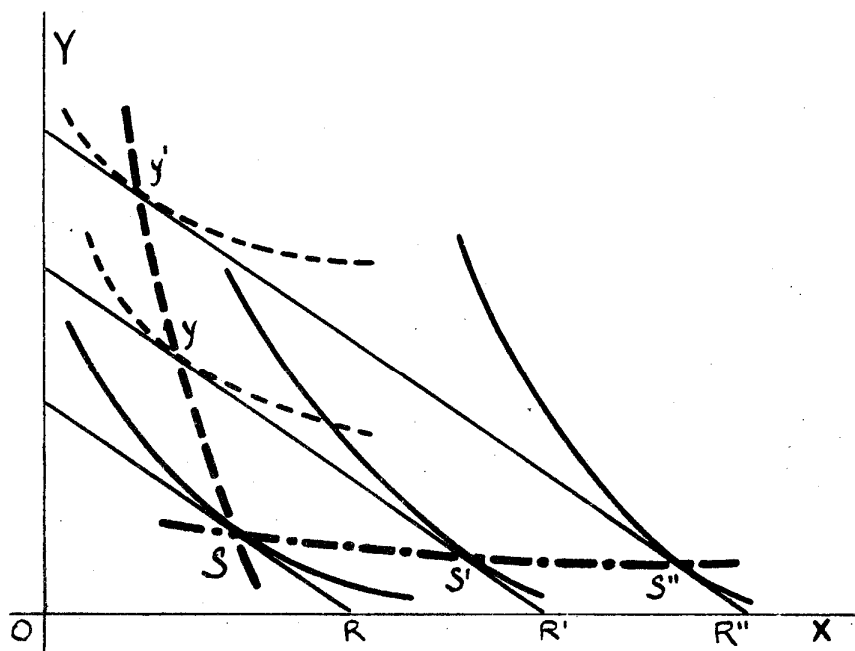
For now we observe that consumer demand of the typical class *P* and *M*, for relatively inferior goods, according to Pareto’s hierarchy (in the limits in which it does *not* affirm *the physiological imperative*), will tend to *accentuate* his distancing from the same goods. If we can put forward the hypothesis of homogeneity of these classes (and of class *R*), we should extend the conclusion to the *collective* demand curves. Furthermore, *for the sake of simplification*, the *repercussions* of the variation of demand on costs and, therefore, on prices, are *disregarded*: this is so because the *definitive* price variation, due to the tribute, is presumed to be *more than compensated* by the variation of income through the financial policy procedures hypothesised, correlated also with the contractual constraints that modify the income of classes of consumers considered here.

If we want to synthesise this order of arguments in a single graphical representation, in particular in the hypothesis of a variation in the price of the superior goods dp_x_i – with the warning that the quantities of “inferior goods” (x_j) are indicated on the x-axis and the quantities of “superior goods” (x_i) are indicated on the y-axis – it is possible to make reference to the following diagram (see Fig. 68). We can see that:

A) qq' = income consumption curve, in function of the same income, placed in a relationship of exchange between dispensable and indispensable goods $\frac{Oa}{Oa'} = \frac{Ob}{Ob'}$; aa' and bb' are lines of real incomes, as they represent the possible choices to two hypothetical but defined classes of beneficiaries of income;



Figura 68.

B) $pp' p'' p'''$ = income consumption curve, modified by the increase in the price of indispensable goods, in the hypothesis that the tastes of the consumer are *not* modified (substitution effect). The exchange relationship, consequent to the differential variation of prices due to the tax, becomes $\frac{Oa}{Oa''} = \frac{Ob}{Ob''}$; therefore the points of tangency through which $pp'p''p'''$ passes are determined by aa'' (and corresponding parallel lines) on the same family of indifference curves (marked with α);

C) $rr'r''i''$ = income consumption curve in the case of a *compensating variation* (or *more than compensating*) of income produces a prevailing *income-effect*. In this case, this effect will be represented by the movement of the indifference curves in the sense of indicating a greater attraction to quality goods. The new indifference curve family is β .

D) The arrows indicate the mode of variation of the choices of a beneficiary of income. From the primitive position q' , following the increase in price in quality goods, he would move to combination p' . When a *compensating variation* takes place, the optimum combination (abstracting from the *income-effect*) tends to p'' . On the other hand, when keeping account of this income effect, the choice of the hedonist beneficiary of income tends towards combination r'' .

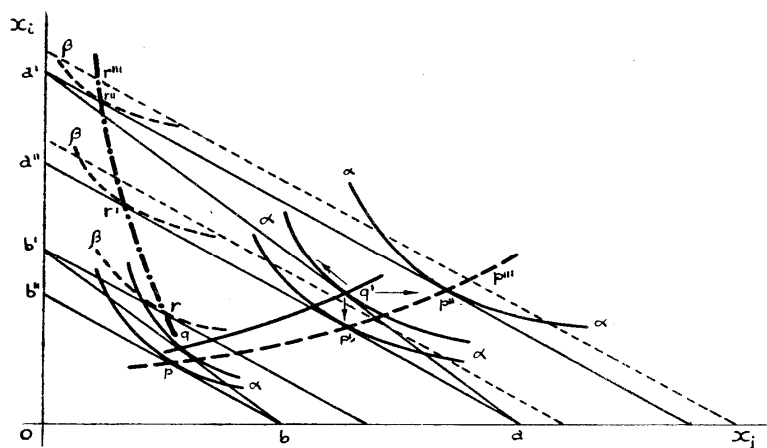
The sense of the variations of combinations becomes apparent:

I) *The price of indispensable goods increases*; their consumption decreases while the consumption of dispensable goods (second quality) increases. We move, for example, from q' to p' . Hypothetically, no account is taken of the income effect.

II) *Compensating or more than compensating variation (without income effect, again hypothetically)*: the decrease of goods whose price has increased is contained in lower limits; consumption of dispensable goods (inferior quality) increases. The consumer passes from q' to combinations found on curve $p'p''$, depending on the extent of compensation.

III) *Taking account of the preeminent income effect*, we see that consumption of dispensable goods (second quality) decreases, while that of indispensable goods increases (significantly, for graphical convention, suitable to highlight the sense of variations that are of interest to us). The combinations, depending on the amount of compensation, which might correspond to $dr \geq x_i dP_i$, are shown in the segment $r'r''$.

Having geometrically completed the representation of the various arguments based on the preceding hypothetical premises, generally speaking there will be the following repercussions, in the context of formal or juridical distribution and in the actual one of indirect taxes on consumptions:

a) progressive concentration of fiscal revenue on relatively “superior” categories of goods or assets and services: generally, modifications of the contribution of taxed “items” with regression to those of “inferior” items, as revenue for the body that collects separate or coordinated or general tributes (on all services and goods);

b) significant (and progressive) incidence with regard to class R and to part of class M , which results in a *profit* in the (monetary) budget of consumers P and M or the “compensating variation” of price (limit hypothesis), because of the hypothesised processes of redistribution;

c) significant transformation of regressive taxes (which are such regardless of the “income effect”), at least in terms of trend, into taxes proportional to the incomes of classes M and P , progressively as their budgets rise [in the spirit of Giffen’s empirical observations or the indications by Marshall, Pareto and Pantaleoni (in the theorem of identity of burden)], steering respectively towards the characters of budgets of classes M (higher levels) and R ;

d) transformation of the general or *proportional* tax on all services and all goods, into a tendentially progressive tax with significant incidence on classes M (higher levels) and R , even without differentiation or personalisation of this tribute²⁴⁹;

e) logically, *the accentuation* of this *progressivity* in the case in which differentiation coexists with the “income effect”) in favour of classes M and P , in the hypotheses suggested here.

These observations are useful in enlightening academics and politicians also on the limits of tributary *burden* and also explain how it is tolerable when the numerator of the well-known fraction that expresses in symbols is represented (t) essentially in the weighted composition by indirect taxes on consumption whose incidence, in *fact*, has taken place in the sense indicated here, because of procedures of redistribution of purchasing power.

H) In using this type of representation, valid for the case of two items (X and Y), it is presumed that the analogous argument (Hicks) has logical value when income is distributed among several goods. Here they have been typically indicated as “inferior” and “superior” or of higher quality. Alternatively it could be possible to compare, in the indifference curves, as Hicks intended to, a physical type of goods (which can be *typical* for the purpose of the argument) to all the others considered together.

If we take into consideration relationships of complementarity and substitution, while *simultaneously* taking into account one variation of monetary income (in the sense of the increase in favour of classes M and P) and one variation of prices, due to the tributary factor, it is useful to make reference [despite referring to Demaria’s criticisms, but to remain with the logical order of the (also graphically recalled) uniformities in the context of directions of demand] to Slutsky’s definition, which identifies respectively complementary, independent and substitution goods, depending on

$$\frac{\partial x_i}{\partial p_j} + x_j \frac{\partial x_i}{\partial r} = \frac{\partial x_j}{\partial p_i} + x_i \frac{\partial x_j}{\partial r} < 0$$

having hypothesised, *generally*, $r = \text{income}$, $x = f(p, r)$ and $r = \varphi(p)$ and in the *particular* case, having admitted the hypotheses

$$\begin{array}{lll} \text{I)} & \partial r = x_i \partial p_i & x_i = \frac{\partial r}{\partial p_i} \\ & & \text{therefore:} \\ \text{II)} & \partial r = x_j \partial p_j & x_j = \frac{\partial r}{\partial p_j} \end{array}$$

²⁴⁹ We can generally place in class M the employees and wage earners essentially affected, as has been explained, by “wage indexation scales”.

Having admitted the variations of income appropriate to compensate for the increase in the price of respective goods, the residual variability of goods x_i is expressed through these inequalities when the variation of price of goods x_j is compensated and vice versa, through a process of derivation. We insist on this formulation, admitting that the statistics help in understanding the correlations between variations of income of typical hedonistic subjects or representatives of classes such as the ones (R , P and M) empirically identified and variations of demand.

From the inequalities it is possible to derive a sense of the variation of demand of the compared (i and j) typical goods, depending on the variation of prices and of the income of individuals representing (on the basis of our assumption) classes presumed to be rather homogeneous of income.

Generally speaking, the *sense* of the considerations taken into account in the hypothetical case of the differentiation of taxation in favour of goods (and services) that are relatively “inferior”, applies in the case, which we can consider equivalent, of the particular or uniform taxation also of these goods, when simultaneously the hypothesis of a “compensation variation” of income is formulated and, in particular, of a *differential* monetary (or equivalent) *advantage* in favour of classes M and P ($dr > x_j dp_j$).

I) In addition, this second hypothetical proposition can be expressed for the relationship of *complementarity*. That is to say, a contraction of the price of “all the other goods” that are in a relationship of “sensitive” complementarity with “inferior” ones (Hicks) will not follow the increase of the price of goods comparatively “inferior” due to the introduction of the *value* tax for the classes of consumers-beneficiaries of income M and P . This is so for the reason that the demand of classes M and P , enhanced by the differential increase in income, will replace in total or in part (and in any case in a manner exceeding the contraction anticipated on the basis of the univocity of the law of demand that is here overcome) the probable contraction of demand for these goods (similarly taxed) on the part of class R (and of the upper layers of class M).

Furthermore, it is possible to generalise this conclusion: the *non-general* or uniform introduction of the tax or rates *discriminating* “against” “superior” goods that are in a relationship of complementarity with “inferior” goods will *not have* as a consequence a contraction of demand of such complementary goods (to the “inferior” ones) and a decrease (or in any case a significant decrease) in the price of the same. This is in the hypothesis of the variation of income of P and M in the measure: $dr > x_i dp_i$, essentially.

J) For the case of *substitution*, with a parallel argument to the previous one, it can be said that an increase (due to the tax) in the price of the main item does *not* determine a proportional *increase* in the price of the substituted products because this tendential variation will be neutralised in total or in part by the contraction in demand of succedaneous goods on the part of consumers of classes M and P with purchasing power fiscally enhanced by “distribution effects” or “transfer expenditure”, with a *net benefit* in favour of the same.

Differential taxes for succedaneous goods may be disregarded, also from this point of view, or at least introduced to a lesser extent than the one essentially envisaged by the authors (who have not complicated the problem in the present terms), without impairing the *progressivity* of taxation or the revenue for the taxing body.

In light of these considerations, it is not possible to hold the uniformity (Borgatta, quoted essay) that is valid in the hypothesis of “hail taxation”, according to which a differential tax on goods or on a group of goods having several replacements acts as a *protective duty* or as a *premium* to production for others. Indeed, the movement of demand towards relatively “superior” *qualities* acts in a sense which is in *contrast* with the content of this uniformity, that is to say, in function of the variations of direct or indirect, real and monetary incomes that are anticipated.

K) Generally speaking, leaving aside specific relationships intended in a wider sense of complementarity, it is possible to widen the overview of the notions considered obvious until now. Indeed, the variations of demand of goods subject to specific or *according to value* taxes on all goods are not a function only of the differentiation of prices for the indirect imposition but also of the mode of distribution of the taxes on assets or on transfers of wealth or particularly progressive taxes on

income, as well as De Viti's "specific benefits" (or policy of *expenditure*) and of administrative protectionism generally.

Furthermore, to neutralise unwanted (for fiscal or social objectives or reasons of other nature) *variations of demand* of goods (presumed to be *physiologically* necessary), it is not sufficient or necessary, in theory (and most likely in practice), to correlate variations of *burdens* or *tributes* on the goods when we leave aside "compensating variations" and those exceeding compensation and contributing to "net benefits" for classes *M* and *P*, which the legislator intends to "favour" *only* in terms of *indirect* taxation.

The significant easing of the tributary *burden* exercised by indirect taxes on consumptions, for the reasons explained here, means that they do not fall on classes *M* and *P* in relation to the juridical distribution of such tributes, even when taxing general consumption goods. In this way their existence in tributary systems can be coherently explained as being compatible with the "social" elevation of classes *M* and *P*, if indirect taxes are, on the other hand, required by consideration of psychological and administrative nature, as means for the deployment of purchasing power, that is to say, when it is simultaneously redistributed through other aspects of fiscal policy.

The *illusion* of the action of the "substitution effect" for the demand of *physiologically essential* goods to increase or not to contract had been dispelled by the preferences that consumers (when a fiscal regime favourable to such goods has been implemented) most likely express for "superior" taxed goods, on which they spend the increase in real income created by such tributary policy. The *illusion* that we have tried to dispel is also the other: that is to say, that enormous taxes on consumptions effectively affect the classes of beneficiaries of income that consume taxed goods, i.e. according to juridical distribution to which correspond the presumed direct relationships with consumer budgets. On the other hand, reality, here hypothetically made clear by the income effect, essentially leads to the identification of charges affecting: *a*) those who are subject to the real, non-general tax on consumptions (*R* and part of *M*) and who do not see the expenditure or distribution of this specific revenue as a discrimination in their favour; *b*) those who are taxpayers for other reasons (taxes on incomes, on assets), belonging to classes *R* and upper layers of class *M*, through fiscal policy and the manipulation of expenditure and of other protectionistic constraints and acts of social policy placed side by side with *contractual forces* in favour of classes *M* (in part) and *P* of the community, that the State leaves free to operate to the exclusive damage of classes *R* and upper layers of *M*.

CHAPTER XII

EFFECTS OF TAX “RELIEFS”

I.

THE IRREVERSIBILITY OF MODIFICATIONS CAUSED BY “FACTUM PRINCIPIS” ON THE CONDITIONS OF GENERAL ECONOMIC EQUILIBRIUM

There are numerous references, in many general works of financial theory, to my treatment of this subject, which had been neglected in the past, probably for the reasons that I will explain below.

Given the time when this short essay was published, that is to say, when mass problems were not yet considered from a Keynesian point of view by arguing in terms of overall quantities in the market, I prefer to make reference to the text in the schematic form it took in 1936. This is so as to leave in the context of “its time” the study which, in term of logical approach, prevent the need for the “revolution”, in a financial setting, that some attribute to the English economist, who has prompted much research in our current times. Probably *also* for this historical reason, I have the honour of having been attributed with priority of thought in this field in terms of the evolution of the theory, in spite of the terse expression which leaves many relationships and many more analytical and explicit quantitative developments to the intuition of the reader. Indeed, the very concise propositions should be developed in an institutional course. However, the new matter that precedes in this edition helps the easier understanding of the condensed thought, in the succinct form in which I reproduce it.

If we disregard the way the collected tributes are used, in other words, the phenomenon of public expenditure, as a favourable event, it is possible to consider the tax at the point of collection as one of the *unfavourable* elements that represent the “risk” in the meaning this word assumes in economic science²⁵⁰.

Among the events involved in the collection of taxes (introductions, collections, equal distributions, etc.), the tributary event is logically not considered by the theory as a favourable event (again disregarding expenditure)²⁵¹.

The confused idea of the “return to the pre-existing conditions of equilibrium”²⁵² is perhaps at the basis of the nearly general lack of consideration for the theoretical hypothesis of tax relief. Briefly, arising from other authors, there is the thought that the State’s refusal to collect the tax reproduces a preceding *virtual condition of economic equilibrium*: that is to say, the one, or one very similar to this, that would be determined without the collection and the expenditure of a part of social income on the part of the State, or without the “factum principis”, as someone concisely expressed it.

I believe that the effect of the abolition or reduction of existing taxes, to clarify some modifications of the economic equilibrium that prevent the realisation, at a time after “factum principis”, of the conditions that historically or virtually would have been determined without it, deserves specific treatment: this is so even if the new measure (decrease of the burden) occurs through legislative modification, which constitutes the reverse – in terms of quality and quantity – of what determined the tributary collection.

Some of the following considerations may have led us to consider as obvious, for the most part, the succession of some of the effects of tax reliefs:

1) being able to consider smaller collections of tax following general tribute-reform as proportional, equivalent to: *a)* an *increase* of *income* of the “pre-existing” categories of taxpayers, whose tributes, “subsequently” abolished or reduced, are collected at a prior time; *b)* an *increase* in *savings* for the same categories of taxpayers; *c)* a *reduction* proportional to “general expenditure”; *d)* an increase of average *productivity* of capitals;

²⁵⁰ M FASIANI, *Imposta e rischio [Levy and risk]*, extract from: “Studi in onore del prof. S. Ortu-Carboni” [Studies in honour of Prof. S. Ortu-Carboni], Rome, Tipogr. del Senato, 1935.

²⁵¹ I reproduce here the elements considered in the quoted essay by the title of: *Politica tributaria Hitleriana e teoria degli sgravi fiscali [Hitlerian tributary policy and the theory of tax reliefs]*.

²⁵² Before the collection of the levy.

2) to be, in effect, an abolition or reduction of particular (non-general) taxes, equivalent to the case of the effects of the *partial* (on some incomes, exchanges, consumptions, etc.) tax continuing to be applied in the market. Such effects would indeed be examined by the theory in the study of the effect of the introduction of a partial or special tax in a wider sense.

The following arguments will highlight some of the reasons why the theoretical case of (general or partial) tax relief cannot be compared, by analogy, to those of other effects of taxes, already examined by financial theory, precisely because of the variation of the determining circumstances.

Having said this, I will put forward the hypothesis of tax relief respectively through the abolition or reduction of *general and proportional taxes* or of *particular or special taxes*.

II.

EFFECTS OF THE “RELIEF” FROM GENERAL AND PROPORTIONAL TAXES ON INCOME

Let's consider the case of the *abolition or reduction of general and proportional taxes on income*.

Let's presume that at a time T there was a flow of annual (monetary) income of 100 available to the community, and that at a later time T' a quota (five) of the annual flow of monetary income²⁵³ of the community has become available to the State to satisfy public needs. At the time T'' it is decided to leave the same quota of income “*at the disposal*” of the community, considered overall, through *reductions* of the *general, proportional tax on income*. In consequence of this, new *conditions* of economic equilibrium will be determined, which will be necessarily *different* from those that were applicable not only at time T' but also at time T , already admitted: the quota of income (5%) that is returned to the community is the same, and so are the circumstances, different from the ones I will consider below. The “old equilibrium” at time T was disrupted by *unfavourable* (collection) and *favourable* (expenditure) events which occurred at time T' ; because of this it is not possible to reproduce at time T'' the state of equilibrium of T or the *virtual* one that would have therefore been determined at T' if the “*factum principis*” (collection and expenditure of 5% of income) had not taken place, and “all” income²⁵⁴ had remained available to the community.

Among the main causes of modification of the economic equilibrium with respect to the two previous periods, following the abolition or reduction of the general and proportional tax, the following circumstances may occur:

1) In substituting the demand of private individuals to that of the State, admitting that the totality of the 5% of income no longer collected is used or consumed, there will be individual supply - demand *curves* not only different from the pre-existing overall State curve (T') but also from the virtual individual ones that would have been applicable at time T' without the “*factum principis*”. This is so because, even when considering individuals to be identical (before the collection and after the abolition of the tax), and the individuals' (taxpayers') tastes to be identical, the phenomenon of interdependence of needs applies. The satisfaction of public needs at time T' is precisely the *premise* for the arising of *other private needs* (new with respect to time T). These can exhibit a “greater” intensity, because of the satisfaction of public needs, or can be “weakened” for the same reason, depending on whether the public supply, intervening at time T' , has put at the disposal of taxpayers durable (instrumental) goods, respectively complementary or “competing” ones with respect to the goods targeted by private demand when using consumption of income which has become available due to the effect of the abolition or reduction of the general and proportional tax.

2) The matter is complicated if, adhering to the real phenomenon, we consider the *individuals* making up the community and their tastes as being diverse, at the different times considered, so

²⁵³ Presumed to be constant.

²⁵⁴ It is intended to refer to all income remaining after the collection of other pre-existing quotas of tributes; in fact the collection of 5% is here considered as an increase of the imposition at time T' with respect to time T .

accentuating the divergence between the different directions of the private demand and supply curves after the abolition of the tax. Depending on case 1) or 2), the *distribution* of income can vary, between *consumption* and *savings*, both on the part of the same individuals and on the part of different individuals with respect to time T and, as for the premise, with respect to time T' , when all income collected gave rise to a public demand or to a consequent and prevailing supply of instrumental goods.

3) If a greater proportion of the quote of income corresponding to the tax relief is *consumed*, after this event, through the purchase of direct goods, both at time T (before the collection) or at time T' , it is possible to obtain the effect of limiting further the existing supply, supposed to be surplus²⁵⁵ to instrumental goods. The substitution of public demand with the new private one can therefore *accelerate* the utilisation of the “optimum” dimensions of enterprises producing direct goods and only indirectly, at a later stage, stimulate the use of “new” private instrumental goods necessary for the production of the first or the production coefficients of the first (direct).

4) By replacing the public demand of instrumental goods (roads, bridges, forests, parks, reclamation, public places, etc.) with the demand of (direct) consumer goods at time T' , a *shorter cycle* of reconstitution of direct goods or private instrumental goods replaces the one, presumed to be longer, of State use of public instrumental goods. The effects of the faster *rhythm* of reconstitution of newly employed capitals are added to the effects of the increase of immediately available capitals (following the abolition of taxes): the sum of the effects is therefore long lasting with regard to *interest rates*.

5) If, following the abolition of taxes, the consequent available capital is saved in total or nearly in total or not immediately reused, or (even worse) it is hoarded by private individuals, there can be a *divergence* at time T'' between the supply and demand of instrumental and consumption goods, greater than at time T (before the collection), as the new supply of mainly instrumental goods (on the part of the State) has been added to it at time T' .

6) The abolition of general and proportional taxes on income increases the *availability* of *savings* and increases the available capital of both producers (industrialists) and workers (consumers): their economic *behaviour* with regard to the public supply of instrumental goods at time T is different from that which, respectively, they would have followed without the prior collection. Some producers will be able to *increase the supply* of new private instrumental goods in function of the greater utility of these, depending on the probable use of public instrumental goods offered at time T' by the State. Other producers will be able to abstain from producing those goods that result in being “in competition” with those offered by the State at time T' . In the case of workers-consumers, a condition of “indifference” can be determined in the limits in which the quota of the abolished or reduced tax increases the availability of their income or savings in the same measure in which an additional demand of work on the part of the State (time T') would have increased it or had made it grow, through an increase in the average rate of wages. Furthermore, the level of consequent prices, of salaries and of real incomes, *different* in the *three cases*, will influence the distribution of greater beneficiaries of income between consumption and savings.

7) The average *productivity* of private use of capitals increases or decreases, if the abolition of taxes modifies private and public curves (demand- supply) so as to stimulate or impede the optimum combination among the instrumentality of public expenditure and the production of private economic goods.

8) The effects of replacing State supply -demand curves with private ones will be different depending on whether the economic cycle focuses on the *ascendant*, *descendant* or *stationary phase*. Generally, in the *descendant* phase, the effects in the sense of an increase in production (of instrumental goods or indirectly for immediate consumption) are to be found when the State demand is “supplementary” and uses capitals and assets not used or consumed by private individuals²⁵⁶. The effects can be considered to be analogous, in terms of trend, but not the same when the abolition of taxes takes place at the *limit*, that is to say, when the supplementary State demand has been exhausted

²⁵⁵ Unemployment, reduced industrial production, etc., can be indices of this situation.

²⁵⁶ See paragraph 6 of the quoted article on *La funzione della banca* [*The function of the bank*], etc.

and private demand replaces it in the prevision of the ascendant phase of the cycle. (This is also so because of the reason given for n. 4).

9) The effects following the abolition or reduction of the proportional general tax mean that the favourable event, considered in itself (restitution or lack of collection), spreads over *uniformly*, as a premise, in the proportions corresponding to the bands of income existing at time T ; however, the second-degree benefits and disadvantages, which derive from the repercussions indicated above, are differently felt by individuals belonging to the aforementioned bands of income, after the abolition of the tax.

On average, therefore, the modifications of the causes of the private and public supply - demand, at times T' and T'' , and the consequent effects prevent the *condition* of economic equilibrium, determined by the reduction or abolition of the (general and proportional taxes), from being considered in principle equal to those at times T and T' , respectively characterised by: *a*) the existence of a sum of savings or income at the disposal of the communities of private individuals as such, greater than at time T ; *b*) virtual causes of private demand- supply, at time T' mistakenly presumed equal (same direction) to those at time T'' .

III.

EFFECTS OF THE "RELIEF" OF NON-GENERAL TAXES

Let's make the case of a *reduction or abolition* of a *particular* (non-general) tax. This can be considered analogous to the case of the *exemption* of incomes or uses, in the hypothesis of the introduction of the partial tax. Classic theory would have seen in this case a movement of capitals from the uses still affected by other taxes towards the one that benefits from the abolition of the corresponding tribute. Conversely, I observe:

1) because when the overall State demand is reduced, demand of a part of the goods offered by producers now exempt by tax will also be reduced; the advantage of the abolition of the partial tax is subordinate (neutralised in total or in part by its amount) to the repercussions that the *State's ceased demand* exercises on the conditions which apply to the new *supply* (time T'') of goods produced by enterprises that benefit from the abolition or reduction of the *tribute*.

2) However, if the pre-existing enterprises "may" consider the relief as a *reduction of general expenditure*, the decrease in prices could stimulate new demands (with respect to time T') on the part of private individuals, and therefore accentuate the advantage of the relief, overtaking the monetary amount of the (abolished) lack of tax, especially if the enterprises are produced in a regime of decreasing costs. In the opposite regime (increasing costs) or that with constant costs, the conditions of free competition or of monopoly and other circumstances can modify the process indicated here.

3) If the abolition of the partial tax does *not* make possible the further use of the sum available in this way in the *same uses* from which it was collected before; or if it is not something that affects producers but *wage earners-consumers*, the benefit can spread in various ways in the market (if they save the amount of the abolished tax) through the increment in the offer of savings, for use in shorter periods than those required by the State and, therefore, through a reduction of the rate of interest. It can also be so through an increase in the demand of other goods, products also from enterprises that do not benefit from the juridical provision of favour, that is to say, of the abolition or the reduction of the partial tax. As we can consider the relative extent of individual incomes to have been modified, and therefore also the type of goods demanded after the abolition of the partial tax, the substitution of private demand to the public one will have as an effect the *greater production of direct goods* in place of instrumental goods; of direct goods of *higher* qualities (with a relatively rigid demand).

4) If the amount of capital corresponding to the reduced or abolished tax is hoarded by those who benefit from the relief, there will be general repercussions attributable to a *contraction of the offer* of savings or in the demand of direct and instrumental goods. As hoarding is characteristic of times when provisions of utility are unfavourable to producers, and because governments often proceed to reductions of taxes (perhaps making use of borrowing) during the descendant phase of the cycle, characterised also by monetary disruption, disturbance of prices, etc., it should not be

considered as an exceptional hypothesis that, contrary to the government's expectations, the amount of the reduced or abolished tax is hoarded. In this hypothesis, the demand- supply of the State or of private individuals would not be replaced by any demand in the market. In this case the absence of a reduction in the fiscal burden would be desirable and equivalent to a supplementary demand on the part of the State that uses available capitals that, otherwise (that is to say, with the abolition of the tax) would be hoarded, in other words, removed from the market. This is a condition that, for the productivistic objectives indicated above, can *induce a preference for the collection and expenditure of a tribute to the total or partial tax relief of the same.*

The circumstances relative to the abolition of the partial tax can be considered as having been made more complicated by instituting the comparison with those existing before the introduction of the abolished or reduced partial tax and recalling some of the cases examined in the previous paragraph II, in which I considered the hypothesis of the abolition of a general and uniform tax on income. Lastly, I do not consider the hypothesis of the abolition of the progressive tax that can be resolved in the case of the partial tax.

CHAPTER XIII

DEDUCTIVE THINKING AND QUANTITATIVE MEASUREMENT OF ECONOMIC EFFECTS OF TAXES

I.

LOGICAL UNRELIABILITY OF THE STATISTICAL DETERMINATION OF THE EXTENT OF VARIATIONS DUE TO TAX

The debates that have taken place with regard to economic effects of taxes have been conducted on a logical basis and with a *deductive* methodology.

There have been those who have considered it desirable that future studies on the shifting of taxes should be addressed to the *statistical* determination of the supply and demand of goods (charged with the tax) and to the statistical determination of the effect on prices of real specific taxes collected in the past on real goods, in real markets. So thought, for example, Prof. E. D. Fagan of the American University of Stanford who, in championing the useful aid of economic statistics for the purpose of studies relating to the shifting of taxes, made reference to Pigou. This author stated that if we are seeking *quantitative* results for the purpose of ascertaining by how much the price of an item has increased after the imposition, it is necessary to know the numerical values of the elasticity of demand and of the supply of goods produced in given time intervals.

However, as I have observed in the relative essay²⁵⁷, simple common sense refuses to accept the following proposition: without the result of statistical studies it is not possible to respond to those who (like the academic Row-Fog) state that the (deductive) theory of shifting represents, at least for specific taxes, a convoluted way to say “God knows”.

Fagan’s and Row-Fog’s positions are not isolated. In the quoted essay, I mentioned the opinion expressed by W. F. Ferger (of the US Agricultural Department), who has become a spokesman for the most commonly-held opinions regarding this. In spite of the fact that this academic feels supported by the opinion enshrined in the “Social sciences encyclopaedia” by Prof. Haig, who underlined the absence of reliable information, based on objective and independent observations, in the area of the concrete measurement of the effects of taxes, I do not, however, believe that the following inference is justified by this logical presumption: that “armchair” economists have preferred the deductive method rather than to “toil to obtain the data and carry out a laborious analysis of the same. If economy aims to be useful and to have the right to be considered a science in the area of shifting, then it must consider the issue of the measurement of the effects”²⁵⁸.

This author also reflects the sense of dissatisfaction that the US Supreme Court had expressed (when dealing with the difficulty of resolving a real case, to which I will refer later) regarding the “inability” of economists to determine quantitatively within what limits the shifting of a given tax had taken place.

I believe these quotes are sufficient to help to understand how the glorification of the values of statistics, even when directed by the most up-to-date economic theory, is becoming widespread even in econometry studies, to the detriment of the established deductive science that has given substance to the shrewd investigations that, among other things, have focused on the study of the effects of the imposition in those countries that have more greatly contributed to the development of financial theory.

Of course, there has been a reaction on the part of public finance experts. However, positions such as those taken, for example, by Dalton, when he states too categorically that nearly all

²⁵⁷ E. D’ALBERGO – *Sulla misurazione degli effetti economici delle imposte* [About the measurement of economic effects of levies], “Giornale degli Economisti e Annali di Economia” [Economist Journal and Economy Annals], Nov–Dec. 1941, Jan–Feb 1942. I will quote from this essay, referring the reader to the source for an in-depth analysis of the issue.

²⁵⁸ *The measurement of tax shifting: economics and law* in “Quarterly Journal of economics”, May 1940.

argumentations of statistical character on the incidence of taxes are worthless, only supporting this with the easy intuition that “a tax is only one of the multiple factors that determine the price of a taxed item”, do not help. Nor is this author any more convincing when he contrasts the argument with a more subtle but obvious reason, by writing that “the effects of the variation of a tax on the price of taxed goods can be, and often are, small compared to the effect of the variations of other factors”²⁵⁹.

With these objections Dalton has essentially repeated what F. Shirras, one of the most recent authors of treatises in English, had also advanced, suggesting that the tax represents one of the “minor” factors that influence the price of goods.

The statement is not totally aprioristic. It is based, however, on the furthermore partial realisation deriving from the Indian experience²⁶⁰. This author advanced obvious warnings on the caution needed in drawing theoretical inferences on the incidence of taxes from the use of price statistics, comparing prices at two different times (before and after the introduction of the tax) in the same or in different markets or countries.

I will not pause on the logical sort of generic objections to those who advocate the use of the statistical instrument for the purposes of study, on a deductive basis, of the significant financial theory issue. Indeed, these authors highlight, in this regard, the difficulty that is generally experienced in the field of economy where the task of the academic is essentially, according to Marshall’s well-known words, to dissolve the intertwined effects of complex causes”.

I believe, however, that specific and in-depth analyses, aimed at finding the reasons that can limit the function of deductive investigations, need to steer us in a different way when they want to verify or integrate the known conclusions reached by those who have made extremely valuable contributions to the study of the economic effects of the imposition. When there have been significant applications, with the help of statistics, and the real phenomenon has been studied, it is required that laws that are empirical and necessarily of limited import in time and in space laws are *related to general principles*, the realm of pure theory.

Sometimes this procedure increases scepticism in respect of those applications that claim to verify deductive propositions. The numerical exemplifications adopted by Coates to support his own theory of the transferability of the general tax on income or on the influence of this tax on the general level of prices has notoriously given rise to various criticisms, to which I will return later.

However, the inference that an illustrious expert such as Duncan Black, M. A. draws from this seems excessive²⁶¹. He generalises the dangers that affect economists when they deal with a complicated part of the theory that involves a certain number of variables, and must rely on the demonstration based on dependable statistics.

However, leaving subjective personal positions and individual propensions aside, I believe that it is objectively possible to test the uniformities drawn by statistical procedures applied to the study of the effects of taxes, combining empirical with rational laws. I believe that the study of the *reasons of the divergences* between the two orders of laws is appropriate in shedding light on the methodology followed by the experts of economic and econometric statistics: *a)* in the attempt to carry out a logico-experimental verification of the theories acquired through a deductive procedure; *b)* in the attempt to discover autonomously new relationships between the quantities changed by the tributary phenomenon. Indirectly the principles acquired through the best-known studies on shifting and the incidence of tributes, through hypothetical or “a priori” arguments, on the one hand are part of the milestones of theoretical thinking in this field. On the other, almost through a process of logical symbiosis (or, as Vinci wrote, “compenetration” of the two kind of studies), they can benefit from a new angle from the approximations to reality that characterise the studies that belong to economic dynamics as a way of conceiving econometrics and economic statistics.

²⁵⁹ *Public Finance*, 1936 edition.

²⁶⁰ Referring, in the 1925 edition of his treatise, to the doubling of the sale levy implemented in March 1923, the author found that the sale price had, in the August of the same year, increased by *more than the amount of the levy* in various locations, while in others it was at a level *inferior* to that which it had been at in other areas in the August of the previous year. This contrast encouraged his scepticism on the utility of the help of statistics in terms of experimentally proving the deductive theory.

²⁶¹ *The incidence of income taxes*, Macmillan, London, 1939, p. 29.

II.

LIMITATIONS OF THE MEANING OF EMPIRICAL-STATISTICAL STUDIES FOR THE MEASUREMENT OF THE EFFECTS OF TAXES

Statistical methods for the measurement of the effects of taxes can be classified as empirical-statistical, in the sense that (without determining the statistical law of demand and supply in light of price theory) they have managed, through a *direct comparison of real prices*, to measure the variations of prices pre-emptively determined by the fiscal factor.

In the investigations of Laspeyres (Germany), Jannaccone (Italy) and Coates (England), the variation of *prices* of goods has been observed, comparing the price of goods, services or incomes affected by tax, at *given time*, with the price of the same goods or service (or income), without the tax, mainly *at a different time and place*.

Basic procedures (especially in the case of the tax on incomes) have proved to have limited reliability. They have also needed the help of pure deductive theory for their interpretation, which has often *not been univocal*, as in the case of the inferences drawn regarding *income tax*, whose influence on prices it was sought to explore, through the close examination of variations of incomes due to the effect of the tax. (See the quoted essay for further details.)

I will now consider more sophisticated procedures of economic statistics, such as the *multiple correlation* or the *price margin* or *price spread*.

As the critics of deductive theory of shifting have mainly taken into account the price-spread system, I will specify that this method, considered more realistic and useful in terms of practical results, consists of what follows. Given *two* (historical) series of prices, it is necessary to examine their *behaviour*, starting from the premise that they present a high degree of interdependence. It is possible that one of the two series corresponds exactly *to the same factors* that influence the second, *in addition to a special* group of factors (causes). Even if the reaction to the *common* factors is not identical in the two series, nevertheless the *differences in prices* do lend themselves to being studied so as to determine the law that regulates their variations. What is essential is that the *differential* behaviour is determined by factors that, in the series individually considered, are obscured by more powerful causal effects. Of course, as I have more explicitly demonstrated in the quoted essay, the discretion lies in the selection of causal factors not common to the two series considered²⁶². Furthermore, little is known about what would have been the *spread* of the series of prices *without* the tax, in the period in which it is applied.

This method was applied in the United States for the measurement of the effects of the *specific tax* on goods, in the context of financial policy of the time.

In 1933 a tax (*processing tax*) was introduced by the government in the United States, charged to intermediaries working in the transformation of agricultural products; its *shifting* was expected to be *charged to consumers*. The revenue from the tax would be distributed to farmers on condition that they reduced production to cooperate with the price policy. The tax was declared unconstitutional in 1936 and should have been *reimbursed* to the taxpayers who had paid (*de jure*).

However, the latter might have transferred the tax to consumers, other producers or intermediaries. And, in the hypothesis of partial or total shifting, there would have been unlawful enrichment (for the part of the tax transferred on other parties) if the State had reimbursed the tax (for example, in the case of VAT on instrumental goods).

To remedy this situation it was directed by law that *processing tax* would be reimbursed on condition that there was *proof* of the “*de jure*” *incidence* of the tax on taxpayers. The procedure that would have given the proof of shifting or the lack of shifting process was that of the price spread.

²⁶² Discretion, as I have observed in the quoted study, not dissimilar to that needed in the separation of the determining elements in multiple correlation.

In one of the cases I considered for examination, that is to say, the one of the taxation of wheat, the *spread* was represented by the *difference* between the wholesale price of milled products and the price of wheat increased by the tax (Fig. 69).

After having described such price spread, I examined its function and its logical meaning with the objective of finding a solution to the problem of the measurement of the effects of the tax.



Figura 69.

If we consider the case of *monopoly*, it is probable that the introduction of a tax gives rise to a small price variation in the product as it will appear from the variation of the differential spread.

However, the spread variation or the difference between prices alone *is not appropriate for the measurement* of the consequence of the tax on the *net profit* of the taxpayer affected. This is an incidence that it is of interest in cases such as the one we have considered for the United States. The costs behaviour and the repercussion of this variation on net profit does not transpire from the statistical method.

It is well known that, as *price* (in the specific case, the “spread”) of the affected goods varies, as illustrated by Edgeworth in considering Cournot’s reasoning, *the monopolist’s loss and profit do not vary in the same measure*. According to Edgeworth’s hypothetical generalisation relative to the type of tax equivalent to what has been considered here, the *loss* of net profit (deriving from the increase of price beyond the relative point of maximum profit) is proportional to the *square* of the increase in price. Leaving aside the case studied by Cournot, who presumed the tax to be “small”, and moving away from the rigid mathematical relationship between variation of price and repercussion on profit that Edgeworth derived from it, we can generally say that the more the price increases (beyond the point of maximum net profit) the *relatively greater* is the loss of net profit. This is inferred, arguing by counter evidence, if the student remembers one of the premises taken into account when considering the properties of the net profit curve, with regard to the study of shifting of a tax on the quantities produced in a monopoly system. Among these properties figured the one relative to the *decreasing rate of increment of net profit* left of the maximum point, that is to say, in a system of decreasing prices. It is easy to realise how the *rate of the loss* is *increasing*, in the inverse case of price increases, while *profit* is simply *proportional* to the increase in prices. We mean here the profit deriving from the decrease in the tax, proportional to the quantity produced and offered, which directly decreases as price increases.

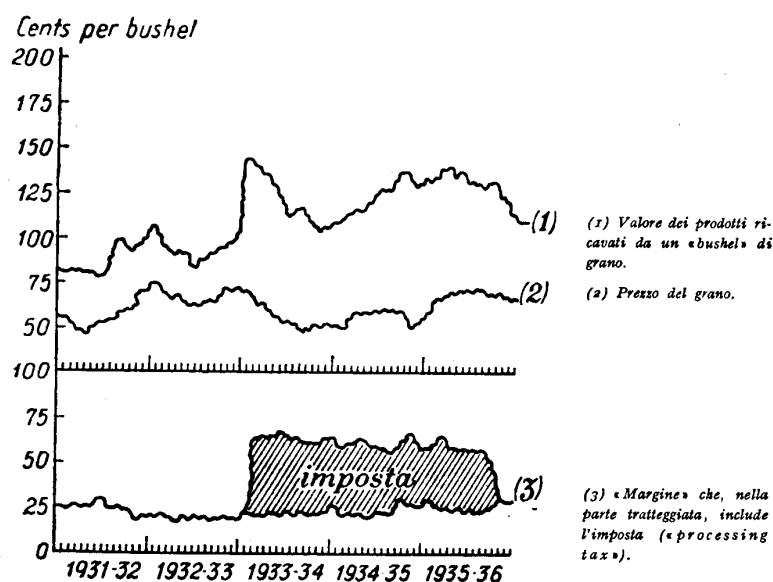
Finally, let’s take into account that we have dealt here with the *direct* or immediate effects of the imposition, without considering indirect effects or the definitive effects *of the incidence*. Indeed,

what is ultimately necessary to ascertain is the *variation of the "relative" economic condition of the individual subjects* whose exchange relationships are affected by the tax.

The spread method does not overcome, other than by wide approximation, the great difficulty of the isolation of the causal fiscal factor. The same difficulty (perhaps to a greater extent) exists in the case where it is not the differential variation of prices that needs to be assessed but the modification of the relative economic condition represented by the *income* that subjects of the affected production activity achieve from relationships of exchange particularly affected by the tax.

However, where there is parity of difficulty, and even admitting the greater difficulty of this second statistical verification, the criterion that aims to compare not a series of prices but *the distribution of incomes over time is more rational*²⁶³.

²⁶³ For further details I refer the reader to the articles published in the November–December 1941 and January–February 1942 issues of “Giornale degli Economisti” [Economist Journal].

CHAPTER XIV

EFFECTS OF ECONOMIC FLUCTUATIONS ON REVENUE FROM TAXES

I.

THE "PASSIVE ELASTICITY OR SENSITIVITY" OF REVENUE FROM TAXES TO THE VARIATIONS OF THE GENERAL ECONOMIC SITUATION

Continuing with the treatment of the relationships between financial phenomenon and market economic equilibrium, I will briefly make reference to the problem of the "sensitivity of taxes" in respect of economic fluctuations.

Faced with the plethora of rich, even if not always excellent, foreign literature on the subject of the relationship between economic fluctuations and the variations of revenue from taxes of different types, given the inexistence of studies of this type in Italy, I did at one time review two essays²⁶⁴ about this issue.

I considered these investigations as belonging to the field of financial issues as they concern the variations, over time, of economic and of political-financial quantities in relation to each other. The general conclusions I reached – in contrast with the foreign dominant theories, that is to say, excluding the possibility of devising a "scale with constant and absolute degrees of economic sensitivity" – could perhaps appear to be characterised by scientific scepticism. However, if account is taken of the conditions that limit the conclusions, it can be agreed that they are more rational, on the basis of the current status of economic-statistical analysis.

What I had defined as "*economic sensitivity*" of taxes (that is to say, the susceptibility of revenues varying with the variation of "circumstances", which I called "economic fluctuations" for brevity and with due caution) was equivalent to "passive elasticity", the term used by foreign authors. Someone, in fact, by establishing a relationship of functional dependence between the sensitivity of taxes and economic fluctuations, had called "passive elasticity" the effects of the variation of the economic situation on the revenue from tributes.

The limitation of the study to economic sensitivity in the case of the following taxes seems very representative for this purpose:

a) taxes on *commercial exchanges*²⁶⁵ proportional to the value of goods, objects of subsequent transactions, in any market;

b) direct taxes on personal or real *income* (considering the main representative ones among these, that is to say, those that affect incomes of moveable nature, without cadastral or administrative restrictions). These are theoretical categories that can be made to coincide with the characteristics respectively of the English *surtax* and of the Italian "complementary" tax, or with those of the moveable wealth tax or *income tax*, with the aforementioned limitation;

c) taxes on *consumptions*, easily identifiable in current positive systems in various countries, leaving aside the formal regulations regarding assessment, collection, etc.

The conclusions drawn by deductive methods, without identifying any contrast with those highlighted by statistical quasi-uniformities deriving from inductive studies, have led some experts to establish the following scale of sensitivity, with the warning that this gradual scale, in a first approximation, also applies to the process of the "*speed of sensitivity*".

²⁶⁴ The first with the title: *Della sensibilità delle imposte in rapporto alle fluttuazioni economiche [About the sensitivity of levies to economic fluctuations]*, appeared in "Riforma sociale" [Social reform], October 1934. The second, which considered the methods and devices to neutralise the "economic sensitivity" of levies, is entitled: *Sulla neutralizzazione della sensibilità congiunturale delle imposte [About the neutralisation of economic sensitivity of levies]* and was published in "Rivista intern. di Scienze Soc." [Social Sciences International Review], Milan, 1935 (July).

²⁶⁵ In the meaning generally given to the expression and which appears, among other things, in my article: 1) *La natura e il fondamento delle imposte sugli scambi [The nature and foundation of levies on exchanges]*, published in "Giornale degli economisti" [Economists Journal], October 1931.

- 1) among the categories of taxes, the one on *exchanges* is more sensitive;
- 2) *direct* taxes present a lesser sensitivity, in other words, a greater “resistance”, with personal taxes relatively more sensitive and real taxes comparatively less so;
- 3) taxes charged on *consumptions* present a comparatively lesser degree of economic sensitivity. This is so generally speaking, and in comparing this category with those in the previous sections, save the further graduation relative to the type of goods affected and the nature of needs they meet;
- 4) on the occasion of the 1939 fiscal reform, among other things, *assets* were adopted as the taxable source (rather than income) as this would allow, from the point of view of tax revenue, a *greater stability* for the State. It is, also in the case of the problem in question, a matter of the sensitivity (of the revenue) of taxes in relation to economic fluctuations.

Comparable to the tax on assets, in a way, is the *registration duty*, included in the category of *business taxes*. Furthermore, on the limited and debatable basis of available statistics, the category of business taxes appears to reflect economic fluctuations in a relatively *more immediate* way.

In the Ministerial “foreword” to the 1939 reform, to which the speaker to the Senate makes reference, it can be read that “the tax on assets has the benefit of a greater stability of achievable tax revenue” (compared to the tax on income). This is so because at times of crisis the level of incomes decreases but so does the relative capitalisation rate.

I do not believe that the relationship considered here can be defined in terms so absolute²⁶⁶. First of all it has not been univocally proven that in the depression phase, disregarding any influence of the public factor, the rate of capitalisation of incomes always decreases. However, above all, when there is a depression phase, that is to say, when there is a *trend* for incomes to decline, it is not the current level that is capitalised for the determination of the value of assets but the future one, which the assessor can *subjectively* forecast to be lower, for a given time, than the current one. In this case the value of assets can fluctuate more than income, in a negative sense, without the difference being able to be neutralised by the variation of the capitalisation rate.

Statistics do not always lend themselves to the verification of this logical deduction. Nevertheless, having warned extensively on the probative capacity of statistics in the previous chapter, I believe that what I state can be identified in the table included in the issue of December 1939 of the “*Rivista di storia economica*” [Economic history review], which reproduces L. N. Bloomberg’s tables. Historical-statistical research has other objectives. However, from the point of view of the economic sensitivity of taxes, the fact that a group of moveable assets, representative of investments in real assets, has seen its own *capital value* (index) *contract* between 1929 and 1932 (bottom of the crisis) in the United States relatively *more* than the decrease in their *actual net income* is certainly remarkable.

Generally speaking, it can be said that capital value, at times of crisis, decreases to under the level at which it should be determined on the basis of the capitalisation of actual income, even though it is admitted that the current rate of capitalisation might decrease to some extent.

In 1934, with new analytical, critical and reconstructive studies, returning to consider the approximate and yet significant financial dynamics conclusions relating to the preceding categories of taxes, I was persuaded by: *a*) the fact that the current sensitivity scale, already mentioned, refers mainly to the economic repercussions of the *characteristics* of the respective tributes, from the point of view of the legislative system and of fiscal technique, without considering in depth the action of the economic fluctuations; *b*) the circumstance that, with very wide approximation, the relative degrees of economic sensitivity, so differentiated, might be valid, with the warning reported in point (*a*), for *long periods of time*; *c*) the insufficiency of economic semiotics, in other words, by the explanation of the relationships of causality or of functional interdependency found in the few treatises on the subject. Other authors have attempted an *experimental* verification of the economic sensitivity of taxes in countries such as France, England and Germany, without concerning themselves too much about

²⁶⁶ So I stated in the article: *Aspetti della recente riforma fiscale* [Aspects of the recent fiscal reform], in “*Giornale degli Economisti e Annali di Economia*” [Economist Journal and Economy Annals], January-February, 1940.

expressing caution regarding the great difficulty of *isolating* the already very complex cause (economic fluctuation) from other concurring events. Among these are variations of tax rates, duration of the taxable asset considered, exemptions, evasions, fiscal policy directives, etc., which act in the fiscal field, independently of the action of the economic situation or *simultaneously* with it.

It is possible to note what the use of statistics for the purposes of experimental confirmation of theoretical conclusions might be by considering the numerous exceptions, limitations and circumstances that do not make them appear to be representative of the relationships of causality or of functional dependence between economic fluctuations and the variations of tax revenue.

However, even if it were to be admitted that there are no elements, which act as concurrent causes not easily identifiable in the effects (variations of tax rates, exemptions, restrictive or expanding interpretations of the object of the tax, etc.), that might disturb this relationship, statistical investigation leads to some results that can *coincide* with those grasped through deduction. However, it does so *without explaining* through which routes (modifications of the volume of production of goods, in the income produced, in consumptions, in prices, in the extent of cycles or phases of the economic situation, etc.) they have been reached²⁶⁷.

This perhaps explains the aversion, of nearly all authors who have dealt with this issue, towards statistical investigation in this field. However, it is something else to notice that real data can be valid within certain limits, through theoretical investigation of relationships of dependence or of functional interdependence. An error, and not only in the methodology, that makes the current approach to this type of problem inappropriate consists in normally considering *absolute and constant* degrees of economic sensitivity of individual taxes, such that the difference between each one and the next remains constant with the variation of the same cause²⁶⁸. The compared sensitivity scale suggested in the previous paragraphs may apply in *first approximation*, to indicate some factors more or less relative to the technical structure of tributes (according to value, proportional, on quantities, on exchanges, on income, on consumptions, etc.) that, *all other things being equal*, may confer upon taxes a different capacity of revenue within given time limits. The procedure could be correct, if the degree of elasticity of the revenue when the legislative order varies (tax rates, exemptions, etc.) is examined, with the conditions of private economy remaining or presumed to be the same.

However, when the economic fluctuation is introduced as primary common synthetic cause, which in turn breaks down in a complexity of symptoms that act as concurrent or secondary causes, it is necessary to consider the variable effects in a chronological order and in relation to their relative pressure that the same complex cause applies on the production-exchange-consumption relationship. In other words, a trend towards an *increase in overall private income* (as an example of economic movement), distributed in *given* proportions between the social categories, gives rise to a *relative* variability of the revenue from taxes on the income produced, on exchanges and consumptions, different from that which can be determined in periods of stagnation (stable income) or depression (decreasing income), both where there is parity of distribution and admitting concurrent variations in the distribution of private income. It is clear that it is not conceivable to have a scale of economic sensitivity whose degrees, referring to individual taxes, have absolute extent and that present a constant differential variance, compared with each other.

On the other hand, in the same way in which an economic variation causes movements that are usually asynchronous and of different intensity from the phases from production to exchange and to consumption, so the capacity of revenue of taxes, referring to the corresponding expressions of

²⁶⁷ In the quoted 1934 essay I had indeed compared an index of the economic situation with the variations of the revenue from some tributes, the most significant for this purpose, individually considered, over a long period of time starting in 1885.

The results reached by means of inductive study fully agree with those already obtained through logic and deduction.

The same thing can be said of the recent work of Dr. C. Costantino (*Imposte e Congiuntura [Levies and economy]*, Giappichelli Editor, 1951, Turin), who has calculated the coefficient of correlation, the index of rank and the coefficient of dependence for each levy of the Italian fiscal system in relation to variations of an economic index for the period 1920–1941.

²⁶⁸ Economic fluctuation, as complex cause.

contributive capacity, in the alternating economic phases, varies in extent and speed mainly in direct relation, *all other things being equal*, to the variation of the above mentioned contributive capacity.

In this sense the technical structure of the tribute [amount of income, of the value and quantities of exchanged quantities, of assets (quantity or value) consumed] is not an independent variable that affects the degree of sensitivity. However, this needs to be linked to the relationship between the economic fluctuation and the consequent variation of the entity which is the subject of taxation, and the effects of different taxes.

The variability of such relationships can be grasped when we consider that the economic fluctuation can be characterised, for example: 1) by an increase in overall private income²⁶⁹, where there is parity of prices, changing the quantities produced; 2) by constant income, varying the prices and keeping the quantities produced the same; 3) by decrease in income, keeping the other two circumstances alternatively the same. To these numerous other circumstances can be added (production of instrumental and direct goods, relationships between consumption and savings, etc.) to complicate the issue. It is also sufficient for this purpose to refer to the “succession” and the “combination” of symptoms identified in alternate or subsequent phases of the economy.

It is therefore possible to state, unlike what is commonly believed, that the comparative degree of economic sensitivity of the three categories of taxes examined is *relative* to the respective relationship between the economic fluctuation and modification of the taxable object of the same taxes due to this. The legislative order of remains unchanged and we consider, simultaneously or subsequently, the factors represented by quantity, prices, time, production, consumption, distribution, etc. This is an example so analytical and linked to the time factor that it escapes complex statistical comparisons, generally speaking, over long periods of time.

A correct theoretical investigation, which could be confirmed by the real phenomenon, were it possible to really isolate the causes and if statistics could be used, must take account in an abstract way of the methodological and substantial approach to the problem I have highlighted in my study, to assess circumstances that, to different extents, with the unfolding of economic fluctuations over time, influence the relative degree of economic sensitivity of the categories of taxes examined. Leaving aside these points of view, it is not clear how the subsequent problem of the adaptation of public economy to the modifications of private economy can be rationally solved, furthermore with the expectation that it might suggest financial policy normatives.

In light of these considerations, let's move on to consider the examples relating to the taxes in question.

A) The tax on *exchanges*, which has a *high* degree of passive elasticity, because of its own structure or due to its formal expression (*according to value*, is collected at several stages in the circulation of goods, etc.), shows a trend to present greater or lesser economic sensitivity the more (or the less): 1) the economic fluctuation is characterised by variation of prices (for example, increase), which is due also to an automatic forward shifting of the same tax; 2) the value of goods exchanged varies to a greater extent than the volume of the same (this is a factor with a high degree of speed of sensitivity); 3) the relationship between the volume and the value of the exchange and its relative industrial or commercial income; 4) by varying the overall private income, the demand of goods whose exchange is subject to the tax remains high (rigid); 5) while private income remains unchanged, the production and exchange of goods in some phases of the economy are fed by monetary capitals destined to immediate consumption (public or public expenditure for use in loans, in other words, through the policy of credit, which creates the so-called *compulsory savings*); 6) the tax, in the alternate or subsequent phases, affects the exchange of instrumental or consumption goods to varying degree and the relationship between the corresponding prices vary in an analogous or opposite sense; 7) in the alternate or subsequent phases of expansion or depression, in chronological order, there is an influence on branches of production whose goods are affected to a varying degree by

²⁶⁹ Papi has considered this problem, and introduced the logical category of *real* income. Essentially, I have implicitly taken account of this in the quoted essays by referring to *quantities* produced. Nevertheless Papi drew other deductions for the purpose of the study of the relationships between levies and the economy in which, furthermore, nominal and monetary variations prevail. (See the article by this author, published in “*Giornale degli Economisti*” [*Economist Journal*], November–December 1940.)

the tax, both in terms of quantity and value; 8) the forced consumption (through compulsory consumption of public services, in particular in the depression phases) has as its object goods more or less affected by the tax, compared to those purchased and consumed with individual disposable income; 9) the asynchronism between the variations in the movement of prices and in the qualities produced is more or less marked; 10) the sale rates are greater or lesser than the duration of the operation of transformation; 11) industrial and commercial enterprises are organised vertically or horizontally; 12) where there is parity of overall quantities produced and level of prices, large, medium or smaller enterprises prevail, when these conditions vary.

These and other circumstances, disregarding the modifications in the legislative system: *a)* can influence in different ways the economic sensitivity of the tax on exchanges, for shorter or longer periods respectively; *b)* can influence the speed of sensitivity.

From the examples that precede and that can be further complicated, in particular considering the differentiation of the tax rates existing in reality, it is possible to note that, admitting a structural trend of the tax on exchanges to quickly reflect economic fluctuations, the relative degree of economic sensitivity is influenced by various circumstances, only some of which are listed here. These circumstances, simultaneously or subsequently, influence the extension (quantity) and the value of the object of this tax to a different extent than that of other tributes with different objectives.

B) Current theory places in second place on the scale of sensitivity, in the context of the taxes that have been considered, the one that affects produced income, in turn differentiated in: I) personal, progressive tax, relatively more sensitive; II) real proportional direct tax, with a comparatively lesser degree of sensitivity.

I) Current theory is induced to make these sub-distinctions mainly for the following reasons: *a)* a high degree of progressivity of tax rates leads to decreasing (rather than proportional) revenues in phases of depression because the crisis leads to a degrading of incomes (on the other hand, a high degree of progressivity in tax rates leads to increasing - rather than proportional - revenues in phases of business expansion); *b)* the trend towards the "personalisation" of the tributary relationship confers greater sensitivity on the tax in an essentially increasing sense, compared to the real imposition; *c)* the abandonment of statistical observations, as the basis for verification (in the context of real taxes) accentuates this degree of sensitivity.

Furthermore, these conditions need to be reviewed and further tuned and expanded, also because, as I have warned earlier, the authors who have reached the above mentioned conclusions consider almost exclusively the structural or intrinsic differences (fiscal technique) without taking into account.

II) The current indication of the degree of sensitivity of the real direct tax on income is established by saying that this type of tribute "stands up very well" to economic fluctuations, to the point that its revenue, even for more sensitive categories of taxable incomes, remains unchanged or decreases "a little" in times of depression. In terms of this aspect, the lack of consideration for the time factor, even in the rough diversification of "short" or "long" periods of time, is clear. Indeed many authors mention the resistance or limited sensitivity of the real tax on income, based on the "duration" of the verification of the taxable income as such, that is to say, over the period of time that runs between the determination of the taxable income and the subsequent verification, in other words, between the determination and the revision, according to the fiscal system of the various countries. There is only a vague mention of the composition of the taxable income corresponding to the different categories of the complex taxes (*income tax* and equivalents) as discriminating causal factor.

However, it is clear that, *over long periods of time*, the effect of the so-called initial resistance is cancelled out, if it takes place in a depression characterised by a decrease in overall private income. In fact, it is necessary to place "resistance", or the variability of the degree of economic sensitivity, in relation to: 1) previous statements; 2) the extent of the fluctuation; 3) the specific effects caused in relation to the production of individual categories of incomes (industrial, commercial, agricultural), from pure work and moveable or land capitals (case of the *income tax*); 4) the variation of the percentages of total income, produced respectively by collective entities, mainly taxed annually on the basis of their balance sheet (which causes them to reflect the economy more closely) and of the amount produced by entrepreneurs for which, in practice, the verification lasts for several years; 5) the

changing of the control regime or corporate system or free trade unions, in particular with regard to work incomes, which can variably influence the relative amount of income that is distributed among the taxed categories, for which different tax rates apply; 6) the formation of new incomes due to the effect of extraordinary state expenditure in periods of depression; sometimes work incomes prevail over industrial profits, as has already been demonstrated with regard to the relationships between the increase of labour occupation and of production on the one hand, and the relative increase of salaries, wages and profits on the other; 7) with the (static) economic constitution of various countries or with the variation of the same, according to the synthetic differentiation by Wagemann into non-capitalistic, neo-capitalistic, semi-capitalistic, high-capitalistic and with the effects that this factor causes in the entities of the different categories of taxable incomes; 8) the different effects that, including public expenditure, it exercises on the formation of new private incomes, when there is State intervention in periods of depression in the form of, respectively, subsidiaries to the unemployed, public works, or the continuation of production of instrumental or direct goods, with the different effects caused by the specific course of action; if necessary, to loans or taxes; 9) the effects that the burden relating to tax rates on the one hand, and the variations of the demand of produced goods or services on the other, exercises on the distribution of capital and labour among the various branches of production; 10) the chronological order, as well as the duration and the extent to which in the subsequent or alternate phases of economic expansion, or of depression, by which various categories of incomes (industrial, agricultural, commercial) are affected, variably sensitive because of their structure, or because of the intrinsic characteristics of the taxable incomes;

For brevity, I will go no further with the observation of the conditions and circumstances that can, subsequently or simultaneously, affect the comparative degree of sensitivity of the real direct tax on income, assuming the fiscal technical factor remains unchanged. It is clear that these conditions and their inverse must be considered in the alternate phases of depression and prosperity. Furthermore, disregarding fiscal technique factors (the duration of verifications, frequency of revisions, variable interpretation of the taxable income, etc.), it is necessary to consider: the extent and frequency of economic fluctuations, the extent of the taxes, the duration and intensity of processes of shifting, collection and distribution of tributes, processes that modify the respective taxable object of the taxes considered including in function of the fluctuations of the economy; this element (economic effects in the classic and limited sense) has a real weight, mainly over short periods of time.

C) Finally, there is the case of taxes on consumptions, which the theory places at the bottom of the economic sensitivity scale, compared with the other tributes indicated. The various authors limit themselves to observe its "rigidity" and to differentiate between the taxes that affect luxury and secondary goods and the relative degrees of the elasticity of demand.

In terms of what relates to *according to value* taxes on consumptions, the considerations expressed in relation to the tax on exchanges largely apply, presuming these to be automatically transferred forward, without multiple passages for the goods involved. In terms of what relates to the part represented by the taxation of produced quantities (the typical case of production taxes), it is not possible to talk correctly of generic rigidity, in other words, of extending economic sensitivity to entire groups of taxes, according to the rough diversification of the object taxed (luxury goods, secondary), because in the context of the same group there are taxed goods that follow different trends of individual demand, in relation to various, direct and indirect, effects of the economic fluctuation. Therefore, generalising, it is possible to place the comparative sensitivity of taxes on consumptions in a functional relationship with the following economic dynamics facts and relationships: 1) the variations of the absolute amount of overall private income and with the modification of its distribution among members of the community; 2) the variation of the relationship between: a) income destined for free individual consumption and b) free savings; 3) the effects that the circumstances at numbers 2, 4, 5 and 8 exercise on the distribution of income among various consumptions; 4) the modification of the type of goods consumed, due to changing tastes, in relation to the prevalence, at different times, of agricultural, industrial or pure work incomes, in the context of the overall volume of private income and with the modification of the composition of social classes and of tastes (due to this) following significant economic fluctuations; 5) the different rhythm according to which the production of instrumental or of direct- consumption goods follow or replace

each other; 6) the accentuation of the “downgrading” of incomes, or with the confirmation of their concentration; 7) the trend of consumption due to State expenditure (collective consumption); 8) the effect that cancelling out taxpayers’ incomes, due to fiscal or economic causes, exercises on the extent and on the nature of individual expenditure, as well as with the repercussions of the modifications of the consumer’s surplus and the variations of purchasing power of the various categories of income, in relation to economic variations (money, extent of salaries, prices, etc.). 9) the different contributions of new and pre-existing incomes influenced by the economy on the formation of classes of income; 10) the changing relationship between production of overall new income and types and nature of direct goods caused by the influence that: *a*) production centralised in (syndicate) enterprises (production or commerce), or *b*) the action of variable costs on prices (in particular in a regime of competition) exercises on the trend of individual and collective expenditure; 11) the fiscal regime of main and succedaneous-consumption goods, and with the shifting of consumption towards goods not yet or relatively less taxed (in other words, with the opposite effect, as I have demonstrated in the context of the financial application of the Pareto–Slutzky analysis of demand, in the quoted essay and largely reproduced in paragraph VII of Chapter XI); 12) the different proportions and with the different moments in which expenditure, both collective and individual, is influenced by (*a*) monetary capitals in relation to (*b*) income, with case (*a*) determining more intense exchanges, variations of prices and diversity of expenditure; 13) the fluctuation of the surplus of goods, taxed or otherwise, whether they are constituted by foodstuffs or instrumental goods; 14) the variation of the number of taxpayers where there is parity of income and having admitted economic variations of this factor; 15) the shifting, in periods of depression or prosperity, of “workers”, with different tastes, from farming to industry and to commerce and vice versa, in particular through public expenditure; 16) where there is parity of tastes, the variation of “modes” (goods, instrument) of the satisfaction of needs; 17) the speed of the increase or decrease of incomes, in particular from work, and of their respective subsistence means; 18) the comparative variations in the level of prices of goods of different types and quality, in relation to the variation of the elasticity of demand and the simultaneous modification of purchasing power.

Also in terms of these taxes, in addition to their “combinations” at different times and for different “classes”, in the mathematical meaning of the term, of the example quoted, the hypotheses can become more complex especially if other factors are considered: variation of customs due to the influence of political education, stability of the political constitution, because of the influences on consumption and on individual savings, modification of laws on sale licences of taxed goods. These are factors that influence economic relationships indirectly and over time. However, above all, the sensitivity of taxes on consumption is dependent, essentially, on the reactions that economic fluctuations determine on the production and distribution of incomes, according to the detailed and variable set of examples presented above.

After having developed this set of examples, it can be stated that the comparative economic sensitivity scale, such as it is scrutinised by current theory, is not absolute and constant, in the succession of the degrees of sensitivity, for the following brief reasons: *a*) because the authors, as has already been said, when studying the issue, even though they formally make reference to economic fluctuations, in practice give more weight to the intrinsic, technical and juridical characteristics of the respective tributes, disguising economic fluctuations behind implicit “*all other things being equal*” considerations; *b*) because statistics, even when they appear to formally confirm, with great approximation, the comparative degree of hypothetical sensitivity corresponding to the taxes considered, do not give correct and clear proof of the sense and the tendential extent of the functional dependence of the sensitivity relating to the cause (fluctuation), which it is not possible to isolate from the simultaneous action of other distinct factors. By saying that the sensitivity scale mentioned above can be verified in a first approximation, we also intend to observe that it can “roughly” correspond to the effects of the technical-juridical characteristics of the respective tributes; *c*) because if it is not possible to refute the correspondence, in reality, of the abstract examples developed by us over long periods of time, due to the methodology warnings already expressed, even more so nothing prevents the symptomatology, corresponding to the same set of examples, in the expression of indices of economic sensitivity, from being confirmed in practice by facts, when it is possible to isolate the

causes, composed of the effects of different economic symptoms, on the respective taxes' taxable income, in the sense or in the order indicated in the previous pages.

An absolute sensitivity scale, with degrees constant in time and in space, can be approximately established with respect to the technical-juridical characteristics of the taxes, largely accepting *all other things being equal* for the rest. However, establishing a relationship of functional dependence of the degrees of sensitivity to economic fluctuations, the comparative scale tends to distance itself from the one previously indicated, within the limits of time and to the extent to which the hypotheses put forward in the letters A), B) and C) tend to come true, subsequently, in chronological order, simultaneously, for combinations of various classes.

II.

THE PROBLEM OF NEUTRALIZATION OF THE ECONOMIC SENSITIVITY OF TAXES

Generally speaking, the authors who have considered the problem of the economic sensitivity of taxes had as their objective a set of financial policy issues extensively debated, and precisely that of the neutralisation of the above mentioned sensitivity, in relation to the stability of fiscal revenue over time. It is not necessary to recall how the assumption of deriving financial policy *guiding rules* from the rational investigations that are the subject of public finance economy is totally extraneous and logically rejected by the vision, which I have previously defined, that guides my approach in this *Course*.

However, I believe it is opportune to pause on the problem of this neutralisation by extensively using my quoted 1935 essay in part to demonstrate to students, once again, the shortcomings inherent in those conclusions that are suggested too quickly, and in any case in an irrational manner, that are suggested precisely under the guise of real *guiding rules* for the governing class of the community.

The question gives rise to the following types of problem: *a)* is it possible to believe a reform of the system of individual tributes or of the "composition" of fiscal systems, on the basis only of a hypothetical constant economic sensitivity of taxes to be logical and possible? *b)* can the adoption of financial policy provisions aiming to neutralise "a priori" the variations of fiscal revenues in their complexity, due presumably to economic fluctuations, be considered rational?

I state right away that the problem in point *a)* is not susceptible to a theoretical solution obtained by deduction, because it is undetermined and this is so because of the demonstrated inexistence of differential, constant degrees of economic sensitivity for different taxes.

From this derives: 1) that the forecast effects of reforms can result in them being different from and sometimes in contrast to those that it is intended to achieve, through the implementation of taxes aimed to resolve the two problems expressed; 2) the error in methodology of those who, from the debatable results of the examination of the above mentioned relationships of functional dependence, move to the suggestion, as "guiding rules", of legislative reforms informed by the logical conclusions deriving from a single point of view or reflecting a single objective or anticipated fiscal effect.

The hypothetical fiscal reforms can act in two distinct sectors: 1) in the context of the system of individual tributes separately considered; 2) in respect of fiscal systems considered overall, and therefore reviewing the variations in the composition of these same systems.

It will be necessary to make reference to the stabilisation of tax revenues, in the double meaning of: *a)* adopting taxes with constant annual revenues and independent of economic fluctuations; *b)* compensate, over a period of several years, for the effects that are presumed due to economic fluctuations, leaving unchanged the fiscal system, so as to make constant over time the average revenue of one or more tributes, by means of various expedients.

Let's presume that, either through the extension of the *all other things being equal* proposition or through the hypothetical admission of the pre-eminence of the objective of neutralising the influence of economic fluctuations on the revenue from taxes, compared to other objectives (of

political, juridical, economic or demographic nature), it is possible to believe, partially or totally, that reforms such as the ones we are considering, intended to modify the system of individual tributes, can be realised.

Among the main modifications of the tributes system, the following are suggested: *a)* the transformation of tax rates from progressive to proportional; *b)* alternate variations of the minimum level of exemption of direct taxes; *c)* the managing of tax rates in an inverse sense of the succession of alternate phases of economic expansion or depression; *d)* the concentration of tax rates (the tax on exchanges) and other reforms regarding the tributes system.

The reasons why it is not theoretically possible to establish a causal relationship between the events (as causes) and the objectives (as the effects) of neutralising the economic sensitivity of individual taxes can be derived by recalling the analysis developed in the previous paragraph. It is in fact sufficient to consider the observations contained in the examination of the hypothetical relationships of logical correlation between the technical-logical characteristics (real and personal ones) of the produced income, as well as those of consumption and on transfers of wealth, on the one hand, and economic fluctuations on the other.

If we move to consider some suggested variations of the “composition” of fiscal systems in their complexity, we find the following reforms among the main suggestions: *a)* increasing the number and relative “weight” of indirect taxes; *b)* the introduction of “neutral” or nearly neutral taxes (capitation or on assets).

Such reforms or other debatable ones do not allow one to rationally resolve the problem of the neutralisation of the economic sensitivity of taxes because, even absurdly admitting the absolute pre-eminence of the objective in question in all fiscal reforms, we would have a “variable entity” (sensitivity) with respect to individual taxes, in different times and circumstances, which would require continuous reforms, sometimes even in the opposite sense and over short periods of time. Furthermore, new problems of a different nature might arise.

In the meantime, in case *a)*, even admitting the convenience of these kinds of reforms (from the point of view of administration, of the economic, psychological, political cost, etc.), a constant difference of degree of economic sensitivity between the two categories of taxes (direct and indirect) needs to be presumed, and this is an arbitrary hypothesis, as I have demonstrated.

Furthermore, with a more analytical distinction in the context of the category of indirect taxes, we find among them those according to value (on exchanges, transfers, custom duties) that – even abiding by current opinion, which we have criticised, with regard to a gradual scale of sensitivity – would have a variability of revenue and a “speed” of sensitivity higher than that of direct taxes, which some experts would like to see reduced in number and relative weight, in fiscal systems.

However, absurdly admitting that indirect taxes, as a complex category, present on average a lesser relative degree of sensitivity with regard to economic fluctuations, there are limits in their replacing direct taxes, in terms of weighting, as to what concerns the revenue, from the static point of view of elasticity when tax rates change, with all other circumstances staying the same. These limits, in practice able to be assessed with approximation, cannot be arbitrarily overcome without causing effects opposed to the objective in question.

Finally, no account is taken of the “compensation” of reactions in the opposite sense that occur in the context of a complex system (direct and indirect taxes) with the variation of the circumstances indicated in the previous paragraph, in terms of distinct tributes, at a given time or because of the influence of the time factor. The process (compensation of reactions) excludes the expected legislative reforms that also might not have, in specific circumstances, a logical foundation with respect to the objective, also for these reasons.

In case *b)*, it is understood that “capitation” taxes are not “neutral” with respect to economic fluctuations because, if we exclude the economic situation of passive subjects, in terms of their revenue, they are furthermore linked to the demographic factor (birth rate, mortality). In relation to what concerns the tax on net assets, we have already made some observations on the causes that oppose its neutrality in terms of economic fluctuations. This applies above all to the *ordinary* tax on assets, of the type introduced in Italy in 1939 and repealed in 1947.

Let's now consider the tax on assets, as a tribute that is applied *extraordinarily*, that is to say, as an institution that allows the realisation of a principle of "insurance" in favour of the State, against variations of part of the fiscal provisions. Let's take a tax rate, presumed to be proportional. In this hypothesis the tax on assets, if it is collected, as has often happened, through planned instalments over a given period of time, could be considered as a series of constant annuities of fiscal credit in favour of the public body.

In a very first approximation, therefore, the problem of ensuring a fiscal revenue for the State, independently from economic fluctuations, could be considered to be resolved. In fact the assessment of the taxable object is presumed to have occurred at a given time with the exclusion of the "time" factor, to any extent, in which variations of value in the component elements can occur due to economic fluctuations.

However, achieving this objective clashes with the general reservation against the premise according to which the neutralisation of the economic sensitivity of taxes should not be resolved in practice by way of the stability of the annual revenue or flow of tributes, even facing the variation of the general economic conditions. Unless, in fact, in order of importance, the problems of fiscal revenue (State point of view) in specific historical periods are considered to have precedence over those of fiscal burden, it is impossible not to recognise that the finality of the relative and absolute independence from economic fluctuations of the revenue raised from taxes cannot be achieved in practice, in given circumstances, without a cost to the community or a to a part of it.

Generally speaking, the authors who have put this hypothesis forward have not moved away from this aspect of the issue.

Furthermore, the cost measured as an increase in fiscal burden could be considered to be nil in the case in which the payment in instalments took place during a period characterised by movements in prices that are equal and of opposite sign, both in terms of extent (quantity) and in terms of duration (time), in respect of the level applicable at the "moment" of the assessment of the value of the assets. It is clear that this perfection of symmetrical movements, admissible in theory, is not always historically proven, and it is not possible, therefore, to believe it to be normal, with regard to the periods in which in reality the payment of the tax on assets is divided into instalments.

Talking about cost to the community or parts of it, we implicitly consider the hypothesis of the phase of economic depression. However, admitting that the burden of taxes varies in inverse proportion to the movement of prices (here presumed provisionally also as indices of economic fluctuations), if in the phase of expansion, with the hypotheses here examined remaining the same, on the one hand a case of fiscal revenue in the De Viti sense replaces the cost to the community (or one of its sectors), and on the other hand it is not possible to reach the final objectives of the State, from the point of view of the problems examined. That is to say, the State achieves a constant revenue, where public expenditure relating to market prices, in the phase of expansion, would require, by likely hypothesis, variable incomes in the sense of prices or of other indices of economic fluctuations.

What has been presented here, with regard to the tax on assets considered in its static aspect (and not therefore in terms of transfers of wealth), applies to a great extent to the system of contingents, in other words, of the fixing "a priori" of the revenue that it is intended will be obtained from some or all of the taxes, when the "time" factor is introduced, maintaining relatively constant the amount of the contingent when economic conditions vary; in other words, without establishing an approximate trend correlation to the real event, between the two elements.

Finally, legislative reform, suggested by some, in the sense of the abolition of taxes with higher-than-average sensitivity, and their replacement with tributes of lesser degrees of economic sensitivity, does not have a logical meaning. Admitting that, in the "hierarchy" of the objectives of financial activity, the one considered here is prevalent, the problem of reform according to such constraints would be undetermined, because the comparison in terms of the tributes that correspond to the objective would be on the basis of a term of uncertain meaning (average) over time.

This average would be, in practice, the result of elements that, on the basis of the treatment in this and in the previous paragraph, represent as many unknown quantities (relative degrees of sensitivity of individual taxes), whose value in practice vary with the alternating of the causes and of the "aspects" of economic fluctuations.

APPENDIX

ABOUT THE PREVENTIVE “ACTIVE REACTION” AGAINST THE OVERALL FISCAL EFFECTS OF ECONOMIC FLUCTUATIONS, THROUGH: A) RESERVES; B) MULTIANNUAL FINANCIAL EVALUATIONS

Alongside the problem of the neutralisation of differential sensitivity with regard to individual tributes or categories of revenues, there is another analogous one with regard to the economic sensitivity of systems, considered overall. It is a matter of the expected compensation of the positive and negative variations that the data from public budgets experience, at parity of tributary systems and qualitative approach of expenditure, due to the alternate succession of economic cycles and fluctuations generally.

We will not take into consideration what the Germans called the policy of adaptation, in other words of passive attitude with regard to the fiscal effects of economic fluctuations. The theoretician can say nothing “a priori” with regard to the management of revenues and expenditure, in either positive or negative sense, simultaneously or in alternative. We find ourselves, in fact, *all other things being equal*, facing an “actual” unknown entity in terms of future expenditure and objectives.

Instead let's examine some examples of active reaction to fiscal effects of economic fluctuations, such as, for example: *a*) the formation of “reserves” for the stabilisation, over time, of the revenue from an (average) source, with regard to one or several more or less sensitive tributes; *b*) the introduction of multiannual plans for the neutralisation of overall fiscal effects on the entire tributary system of economic fluctuations.

I will point out that these are most likely unknown entities to which only the politician, i.e. the governing class for the community, can assign a real value at different historical times: 1) the “base” on which it is necessary to maintain tributary revenues stable; 2) the limits of public expenditure in the succession of circumstances of various type.

Having made this premise, let's presume that we have a “reserve”, from which we can draw in periods of decreasing revenue (or economic depression) from some tributes, and that this reserve is made up of: *a*) the difference between the real revenue of individual taxes and that given by the average over several years; in other words *b*) surplus revenue, overall, in respect of total budget expenditure at specific periods, presumed to be of economic expansion. This reserve will formally consist of public securities (State bonds).

On the basis of these premises, in my quoted essay from 1935, I pointed out that the formation of reserves with the means referred to in point *a*) cannot be considered independent from that in point *b*), but implicit in this, because a deficit budget and a simultaneous revenue surplus with regard to the revenue of some tributes cannot be considered to have real meaning. In this latter case, the surplus would only be a formal one, that is to say not “actually” considered to be so, but only with respect to the average of the revenue of an arbitrary series of preceding years. The two cases (*a* and *b*) need therefore to be logically considered together.

If State bonds, which make up the reserve, have been purchased on the market, most likely through public expenditure, this same reserve in terms of purchasing power *only formally exists for the State*, because it is made up of monetary capitals (in a first instance) and in the form of various investments, in private hands. These private resources could subsequently be activated by the State to neutralise lesser revenues due to economic causes, both by making use of extraordinary taxes and indifferently by recurring to previously purchased (read *amortised*) securities, or to newly issued ones. In fact (leaving aside psychological and political effects), whether the State sells its own previously issued bonds, presumably issued during a phase of expansion (high rate and low price), or it issues or sells for the first time “new” ones, the sum in monetary value that can be achieved at market price will be the same in both cases. This, as a source that feeds the reserves, is in function of the credit that the State enjoys at the time of the sale of old securities or of the issue of new ones, of the discount rate applicable in the market for bonds and similar long-term investments, etc. The claimed advantage of

accumulating reserves made up of amortised and not written off securities seems therefore deceptive or simply an accounting process.

On the other hand the purchase of securities on the market, as a procedure of *amortization of public debt*, presumed to be consolidated, cannot be considered as an act determined only by the policy of stabilisation of budget resources, but by a set of political and economic reasons, as we have warned elsewhere.

In any case, the formation of reserves represented by government bonds is founded on the consideration of the evolution of public budgets. In fact the surplus of revenue from some taxes or overall, referred to in points *a)* and *b)*, is unhistorical because it considers the final offset to be unchanged, in other words public expenditure to be “*untouched*”.

Furthermore, if the “reserve”, made up of government bonds is a negative reserve, it is necessary to abandon the analogy mistakenly drawn from individual economy and discard the deceptive criterion, which someone would like to see sanctified in laws, to search in such reserves the means to neutralise “a priori” the fluctuations of financial quantities, due to economic fluctuations. The surplus destined to the purchase of securities only formally continue to be dedicated to not written-off securities by the State. Their eventual sale, in a phase of economic depression (which should not be confused with the transfer of nominal capital [??]), is not very different from new debt that automatically, within limits not exactly predictable, covers the divergences occurring in practice, without constant rhythm or known in advance, between revenues and expenditure, due to a set of determining causes.

The extension of the concept of savings to public finance, as a process of distribution of fiscal revenues over time, alongside the concept of “reserves”, has led to the idea of a multiannual financial plan, sometimes over ten years, according to those who believe in such a period of recurrence of cyclical phases.

The methodological error that pervades this type of suggestion seems clear because: 1) the time factor, in variations from 1 to 5, to 10, etc., ends up postponing rather than solving the problem of the neutralisation of the complex variations of fiscal revenues. In fact, in the same way as in the course of a normal business over one year, fiscal effects are found that are not always the same or quantitatively determinable “a priori”, due to the influence of seasonal fluctuations (whose extent is unknown, if they are considered, as it happens in practice, to be in turn affected by cyclical or other influences with long-term aperiodic trends), so the same problem needs to be considered when lengthening the duration of the financial period.

Indeed, also in the case of the multiannual period, even when there is the attempt to make this coincide with a presumed cyclical recurrence, with symmetrical phases, this does not allow to determine more precisely the problem of the neutralisation of the fiscal effects of economic fluctuations.

There is in fact a decisive reason against multiannual budget “plans” for public bodies, presuming this reform to be feasible from other points of view. This is because, even when it might be possible “a priori” to determine the length of a financial period to include opposite phases (depression and expansion), with presumably exactly symmetrical trends, the problem would not be rationally resolved by taking into account real statistical frequencies.

The following relationships between variations in “space” and “time” in the general trends of “political-financial quantities” (public budgets) and of economic quantities (wholesale price indices, presumed indices for the variation of economic circumstances) have been statistically ascertained with sufficient approximation. To be more precise, for some countries and periods variations of financial quantities have been found to be mainly: *a)* more or less “rapid”; *b)* more (or less) forceful than economic ones; *c)* “similar” to these. Generally speaking, both for shorter and for longer periods of time, there have been occurrences of “concordance” of the variations of quantities compared here, and this is because of a set of constant and accidental circumstances, conflicts and resistances of easy intuition.

In conclusion, it should be clear that: 1) the degree (speed, amplitude) of economic sensitivity of taxes is a variable whose value is difficult to know, in function of which it would not appear to be logical to reform tributary systems while furthermore neglecting to consider the “hierarchical degree”

of reasons (juridical, administrative, economic, etc.) that, with varying weighting, over time, have contributed to the determination of the “actual” tributary system of the various countries.

[The same can be said about the relative importance of individual tributes, in the context of systems, for the cases in which it is desired to arbitrarily alter their composition, in the search for a solution for the problem in question]; 2) this variable, for the reasons explained in the preceding paragraph and in this one, is not only unpredictable but also difficult to determine analytically, by observing the past; 3) independently from provisions in this sense, on the part of government people, there are automatic compensations between economic reactions of individual tributes, in the context of revenues; 4) the presumed reforms could ultimately have effects in a certain way, considering some aspects or phases of the economic fluctuations (prices, quantities produced or exchanged, nature and limitations of public expenditure, expansion or depression phase, etc.) at the time in which transformations of tributary systems are introduced; 5) in practice, the ultimate and overall differences between revenues and expenditure, in the short or long term, are known to the governing class without exact differentiation of the determining causes, so that their compensation takes place historically through the empirical evaluation of current and complex circumstances.

In the depression phase, to which most of the authors implicitly refer when dealing about the problems of the neutralisation of the economic sensitivity of taxes, divergences between revenues and expenditure can be essentially compensated for by recurring to loans or to extraordinary taxes. The respective limits of the use of these two financial policy instrument, by adjustment from the original static Ricardian hypothesis, will be fixed in an empirical manner by the combination of variable contingent circumstances, hypothetically already suggested by critics, especially Italian ones, of the English economist. It would in fact appear that it is not beneficial to determine “a priori” in this system of problems the extension to public economy of the concepts of “reserve” or of “savings”, in the forms examined here, that have different meaning in the field of private economy.

CHAPTER XV

THEORY I) OF THE TRIBUTARY AND FISCAL BURDEN AND II) OF THE EFFECTS OF PUBLIC EXPENDITURE

I.

THE THEORY IN THE HYPOTHETICAL CONTEXT OF A STATE

D) ANALYSIS OF THE TERMS OF THE RELATIONSHIPS USED TO EXPRESS THE CONCEPTS OF “TRIBUTARY” AND “FISCAL” BURDEN.

It has been written that this notion, better than any other, synthesises and highlights the differences in the mode of studying and conceiving the financial phenomenon. In our case, it offers the opportunity to reconnect with the scientific vision that directs this treatise, coherently offering the possibility of thinking in terms of *synthesis*.

Indeed, priority has been given to *analysis*, referring to the types of constraints, each time taken into consideration, both considering the technique (modes of tributary distribution) of these constraints and the economic effects on the exchange relationships of goods and services. When the nature of the problem or the appropriate vision of the economic equilibrium has required it, we have also taken into consideration the aspect of public finance represented by the expenditure and distribution of the sums collected, using the aforementioned constraints.

In Chapters X and XI we identified limits in which it is possible to go forward in financial theoretical studies, taking into consideration mass phenomena and overall quantities (State income and expenditure), also from the point of view that the current theories consider, in dealing with the full use of productive resources, and in correlation to the increase or the stabilisation of collective income, including by using the management of public incomes and in particular of public expenditure.

What precedes, especially in terms of analysis, and with regard to the rational vision of the overall financial event that consists of the public collection and expenditure, allows us to deal with the essentially synthetic theory of fiscal burden with awareness of the facts. Not only does this lead to the more or less explicit application of analyses relating to the modes and effects of individual constraints, but also to the reconsideration and almost to the evidence of the logical position adopted here in the explanation of the tributary phenomenon. As we have seen, this is carried out from the point of view of the governing class that interprets, considers and compares, on behalf of the community and its components, the cost or burden of the collection and the utility of the distribution of wealth, making the terms of the comparison homogeneous, in its own judgment.

In other words, it would have been possible to say, with regard to the explanation of the actions of the governing class (which drives its own financial activity up to the point of making the cost to and the utility for the community reasonably equal) that it drives fiscal burden (a term, as we will see, more comprehensive than tributary burden) up to the point where it is, at least, neutralised by the utility of public services supported by the expenditure of the revenue.

This will necessarily become apparent from the consideration of the terms of the argument that are heterogeneous and do not focus only on the field of comparison of the variations of quantities objectively considered, as we will see in the following pages.

This short introduction will soon be clear, as we move to define the concept of fiscal burden, again from a synthetic point of view.

Indeed, from the analytical-atomistic point of view of the burden of *individual* tributary *constraints* that we have discussed, especially in the sense of pressure of the percussion, as a moment that can direct the taxpayer (who finalistically aims for the conservation of the conditions of maximum satisfaction pre-existing the tributary event) towards attempts to transfer, remove, etc., the same tributary burden.

From a synthetic point of view, the pressure or “burden” has been synthetically treated by English-speaking experts, taking into consideration the overall phenomenon or arguing in terms of

sets of events. However, we have not reached a univocal meaning of the concept and its corresponding phenomena.

We have mentioned, with this expression, the overall burden felt by the members of the community or the cost of the collection of a part of wealth, considered in itself or related to that available to communities and individuals, either disregarding or before the State intervention (compulsory or costly collection of revenues and public revenues and expenditure). The illusion or the sensation of the psychological burden brought about by the collection, especially if this is through conscious payments (and not hidden as in indirect taxes where they are confused with market prices), has been considered alongside the idea supplied by the objective extent of the quantity collected and spent. However, this has been done in relation to the benefits of public expenditure, which individuals often do not appreciate, by finding the suitable context, for the mass problem, for the calculation on the part of the governing class. When faced with the subjective and objective elements of the pressure exercised by the modes and the *quantum* of the achievement of revenues different from those over which elements of the community exercise a free choice, and those similarly subjective and objective aspects relating to the effects, more or less advantageous and useful for the community, of the distribution of the revenue so obtained, this is ultimately useful in comparing the elements of the calculation of the fiscal burden, which do not focus, as we will see shortly, only on the field of monetary quantities and their variation.

We reach this solution of the problem of the interpretation of the fiscal burden, in fact, also when we start from what we call the objective conception of the synthetic concept.

For example, Pantaleoni, author of a well-known essay on tributary burden (a term which is less comprehensive than “fiscal”) calls it “the realisation of the relationship between public revenues (because they are collected from the taxpayers), the wealth of citizens and the importance of the return of the same received from the activity of the State”. In other words, it refers to signals that express the “variations” of that relationship.

However, the subjective element also plays a part in this objective vision of the relationship between monetary quantities, as it is necessary to take into account the *importance*, including in terms of subjective utility, *of returns from the State*, in other words, of public expenditure, especially for the so-called immaterial goods and services offered by the State.

Other experts (for example, Borgatta, who dealt with the issue several times, and also with statistical studies) identify fiscal burden as a relative concept, interpreted and calculated in the following most common forms:

a) the relationship between the net sum of public contributions paid by a community in a given period of time (calendar or financial year) to the State and to other coercive bodies and the amount of the private income in the same period;

b) the relationship between the net sum mentioned above and the population of taxpayers (average fiscal burden per inhabitant, per productive individual, per family group), etc.;

c) the relationship – which takes account simultaneously the “private wealth” and “population” elements – between the average tributary burden per inhabitant and the average income per inhabitant.

Other methods to add complexity to or perfect the expression of the concept relate to the reference to the distribution of incomes, to the exclusion of an individual minimum amount, necessary for life or a collective given minimum standard of life, especially in order to proceed to international comparisons; furthermore, both for these mentioned comparisons in space and for those of concern to the State itself, at different moments, over time, the differentiating element between tributary and fiscal burden is the different composition of tributary revenues, depending on whether they are constituted of the revenue of indirect taxes on transferred and consumed wealth or by direct and progressive tributes on incomes and assets, etc.

Also remaining in the context of relationships between quantities expressed in currency, there is no agreement with regard to the composition of the terms of the relationship, both as to what relates to the numerator and as to what relates to the denominator of the relationship.

A) In a strict sense, that is to say, referring to the concept of *tributary burden*, it would be necessary to include in the term amounts collected through tributes according to the meaning in which

the classification of these lessons has been carried out, both if they are collected by the State, and if they are considered in the balance sheets of lesser, territorial and institutional public bodies, having the power to enforce collection (including, therefore, contributions to unions, social security and insurance institutes, etc.) and costs of collections [premiums]. The additional obligations imposed on taxpayers in the modalities of application of tributary constraints need to be added to these.

As we have considered the revenues of fiscal monopolies to be an *alternative* with respect to taxation of consumptions (with taxes on quantities produced and sold), it is necessary to also include under tributary revenues the revenues from monopolies, less the proportion needed to meet the industrial cost of production and the commercial cost of distribution of fiscal monopoly goods.

B) *α*) By expanding the concept of pressure with the qualification of “*fiscal*”, it is possible also to include in the numerator of the relationship the greater cost to the community of the management of enterprises for which quasi-private and public prices apply (public cost higher than the cost would be if a similar enterprise were to be managed by private entities with free employment of productive factors).

β) The same can be said of the cost to the community for the servicing of loans; this is not so because of the higher or lower interest (either compulsorily imposed or varied), an interest to which a tributary imposition for the service of the loan applies, but for the reason I highlighted in 1933, in the quoted essays on the amortization of public debt. I am referring to the fact that *available capital*, from which the public body draws when issuing loans on the market, is a quantity that *depends* on the interest rate that it adopts. This rate can be restricted or increased so as to give rise to a redistribution of capitals among various uses, which may negatively modify the other term of the relationship, represented by the income- or private wealth-dependent variable.

In this sense I put forward the concept of the pressure of public loans in *Rivista Bancaria* [Banking Review] (1946).

γ) Furthermore, it is necessary to make reference to the pressure or to the cost of the recourse to emission of currency in anticipation of this pressure on the part of the issuing bank in favour of the State, when an offset is not created through State activity to neutralise the inflationary effects.

This is not the burden or sacrifice constituted only by the “forced savings” that, for short periods, are imposed by the additional issue of currency because this normally reduces purchasing powers for some categories and increases it for others. It is rather the *ultimate* long term effect, which is translated in a real tributary collection in terms of reduction of real incomes and capital values, due to the devaluation of private incomes and credit, following the increase of the currency in circulation. At least for State securities (bonds), whose value is crashed by inflation, it would be necessary to show the burden affecting the bond holders in terms of fiscal burden.

The issue is relevant, when considering different groups in the community. Someone, who, however, fears being classified among the heretics of economy (following the famous Gesell), even suggested (BRIEN, *Vers la suppression des impôts par l'inflation dirigée* [Towards the suppression of taxes by managed inflation], Brussels, E. Bruylant, 1949) the alternative of taxes and managed inflation.

Here we allude to the recourse, inevitably spent or implemented with planned *deficit spending*, to the emission of currency to pay in particular for expenditure, mainly extraordinary and sometimes ordinary expenditure, when it is a matter of implementing the intervention suitable to tendentially increasing the income of all the community, through the increase of occupation of productive resources, in given phases of the economic cycle, in the spirit of Keynes’ “full employment”, to which reference has been made before and which will be mentioned again later.

In these clarifications, the intention was to implicitly keep in mind a more or less constrained economy to identify terms of the relationship that expresses the fiscal burden, as we will see, in a rough and approximate way.

δ) However, even in a *totally constrained* economy, there may be *in part* the recurrence of elements of the relationship that, with good reason, F. Vinci, like other academics, believes to be “perfidious” in terms of a definition of the “tributary” burden (in the quoted *Istituzioni* [Institutions], p. 71). I say “in part” because it is necessary to take account of the revenues that “public entities” acting in the field of production procure to pay for costs, as I will explain, revenues that are distinct

from tributes in the traditional sense of diverse systems. In a collectivistic economic system, for example according to Vinci (*Gli ordinamenti economici [Economic systems]*, Vol. II, Giuffrè, 1945, p. 26), the “calculation of *fiscal burden* would be interesting if limited to the relationship between the revenue from taxes during the year and the corresponding value of direct or overall family incomes, that is to say, total family expenditure”. He adds: “The relationship between gross revenues of State enterprises and the value of the income for the community would certainly still have meaning, however, but it is clear that such a relationship would not provide a measure of the degree of the intervention by the State in productive activity, which would already be at its maximum; it would, however, feel the influence of the nature of the products in relation to productive technology”. By saying that “this places the complexity of such a relationship in a better light, even in the liberistic economic system, and warns against its simplistic interpretation”, it would appear that Vinci intends to also make reference to the *differences in productivity* of the productive State combinations (compared to private ones) to which we have referred above, as elements of costly financial activity.

To highlight how, even in the view of other authors, even in a completely constrained economy, in which the State takes on total production, fiscal burden, *in the sense in which we have discussed in these pages* (defining it as “tributary” in terms of the part that concerns the collection of entries with this nature), prevails, I quote an extract from U. Ricci (*La pressione fiscale [Fiscal burden]*, “Rev. d'Ec. Pol.” [Political economy review], N. 2, 1937).

He defines the coefficient of nationalisation as *financial pressure*, conventionally to differentiate it from the fiscal pressure (for example, of production). “We observe that financial events are public expenditure and public revenues, and that, if production is nationalised, expenditure and expenses must increase. However, *a public revenue is not a fiscal revenue*: we consider as *fiscal* only the revenues that are required for *indivisible* public services, that is to say, the tax is the fiscal revenue (at the most, taxes may be added).” So it should be said, continues Ricci’s argument, in the case of an integral economic collectivism, with nationalisation of all the enterprises that provide revenues, that financial pressure (coefficient of nationalisation) is 100/100: however, if in different ways, a fiscal revenue (let’s presume it to be 30% of the national revenue) is obtained with formally collected (direct and indirect) tributes or with a price policy, then fiscal pressure is limited to this amount. This demonstrates that also in this, which is the maximum of constraints, among the conceivable hypotheses in theory and in reality, the fact represented by a relationship that indicates fiscal pressure (tributary pressure, in the strict sense) is valid.

If we take into account the differentiation I made earlier between “tributary” pressure (to which Ricci refers with his “fiscal” term) and “fiscal” pressure, it can be said that both concepts are compatible with the hypotheses of a totally nationalised economy.

Having generally identified, in other words, because of their nature, the monetary elements of the numerator in the relationship that would roughly express fiscal pressure (compulsory collections and costs for the community determined by financial activity), the denominator can be found in the overall private income “gross of the tax”, in other words, such as it is *before* payment of taxes. This has been expressed with $R = \Sigma r$ to indicate that the national income is the sum of individual incomes, private and public ones, without any deductions for taxes. (The portion of income made up of wages from public bodies, pensions and interest on debts, on which taxes and tributary revenues collected by public bodies are spent, are excluded.) Griziotti also highlighted assets as a term of the relationship. However, we are debating here in terms of “flow” and not of “funds” of wealth, essentially. In a first approximation, adopting the respective symbols, T to indicate the quantity in the numerator as qualified above (point A), and R for that of the denominator, it can be said that

$$P_{it} = \frac{T}{R} \quad \dots [I]$$

expresses the concept of *gross tributary* pressure (which, as has been seen, can refer to an entire community or to individual components having in this second case “the average tributary burden”).

If we express, not the restricted concept of *tributary* pressure, but the wider one referred to in point B), that is to say, *fiscal* pressure, it is necessary to modify the symbols, adding S (burdens referred to in points $\alpha, \beta, \gamma, \delta$), in the nominator (and then adopting s for the increase):

$$P_{\beta} = \frac{T + S}{R} \quad \text{---- [III]}$$

Let's use [I] for the introduction of other factors, for the purpose of simplification.

The term *net* tributary pressure has been expressed by the modification of the relationship, taking from the numerator the monetary value of “advantages”, “profits”, “restitutions”, etc., which, with public expenditure, determines financial activity for the community or groups and individual members of it. Therefore:

$$P_m = \frac{T - V}{R} \quad \text{---- [III]}$$

Static or photographic expression that, as Pantaleoni stated, has little practical importance if it means “tolerable or non-tolerable” pressure.

“To appreciate the financial situation of a State, it is essential to be able to say if the cost of the State for the taxpayers of a specific country, at a specific time, is an *increasing* or decreasing *burden*”. “Now the question of movement of tributary pressure,” – Pantaleoni continues – “is clearly broken down into two coordinated questions, that is to know, on the one hand: 1) if the wealth of the people (which the State absorbs, at a given time and for its objectives) is equal, greater or less than it was before; and 2) if, on the other hand, the employment of means that are available to the State at the time taken into consideration is such as to make, where there is parity in the portion of wealth absorbed, the burden for the taxpayers more or less onerous than before”.

Therefore the *time* factor is essential and determines when we want to interpret the concept summarily and roughly expressed by the symbols in the relationship.

For example, in suggesting the effects of public expenditure, Borgatta recognises *two phases*:

a) the first, which he defines as *monetary*, that relates to phenomena relative to the purchasing power that the State temporarily takes away from private individuals with the tax (or the loan). It corrects the erroneous notion that a certain amount of purchasing power is “subtracted” from the community with the tax, in this first phase. “All the purchasing power that private individuals momentarily transfer to the State in the form of a tax is rapidly re-issued in the private market through State expenditure”: the author highlights this, with the exception of “petty cash”, and presuming that there are no additional emission of payment means.

b) The second phase, which he denominates the *economic* phase, is “that which regards the definitive and substantial effects of the same expenditure on the amount of (real) income and of national assets.” “In practice it is inseparably connected to the monetary phase, because it starts at the point of the purchase of real goods and services with money paid by the State and continues with the changes of the productive structure deriving from State demand replacing private demand. It is not, however, exhausted in these repercussions. Changes of directions of investment of savings, of the productive structure, of the distribution of national income, are indeed significant economic effects but strictly linked to the redistribution of the State's purchasing power: they do not yet answer the question: does State expenditure increase or decrease the real income of the nation and real assets existing before the fiscal collection?”

“The essential point is to establish which consequences will derive, in relation to the nation's real income and real capital, from the goods and services on which the State uses the tax, in the particular use and destination that the State directs them to; ultimately, to ascertain if the use made of them by the State increases the current and future flow of assets enjoyable by the community to a greater or lesser extent than if it had been used by private individuals”. (Paragraph 37 of *La finanza della guerra [War finance]*, Gazzotti, Alessandria, 1945.)

Borgatta criticises the *univocal* response that the so-called economic theory of finance expects to provide, for which, “a priori” the destination of a part of the national wealth to be used by the State, through financial activity, increases income, as the “more useful” employment might do, which therefore contributes to maximum satisfaction or the maximum of ophelimity. (We will see shortly which vision should be given, as we have already mentioned, by the problem when we introduce the subjective utility variable.)

In any case, if we wanted to give some idea of this with the not yet completely adequate symbolic expression that follows, it can be said that tributary pressure can increase, stay the same or decrease, in comparison with another given moment, depending on the sign that, “a posteriori”, it is possible to insert between the following relationships:

$$\frac{(T + t) - (V + v)}{R + r} \begin{matrix} < \\ > \end{matrix} \frac{T - V}{R}$$

(presuming that r is an increase of income over time).

If we imagine the difficulty of giving monetary value to useful services V and v , in other words, if it is possible to translate in objective quantities “the importance of restitution”, to use one of Pantaleoni’s expressions, we can not only conclude that the tributary pressure has remained unchanged or even that it *does not exist*, if the value of the effects of State expenditure neutralises the distraction of incomes from the destination they would have arrived at in the hands of private individuals, so cancelling the same tributary pressure.

However, interpreting adequately the inadequate symbolic relationships, it is possible to reach a value of $(V + v)$ higher than $(T + t)$, that is to say, to the subtrahend being greater than the minuend. *Arithmetically*, this means that the relationship becomes negative, in other words, that fiscal pressure decreases to the point of being cancelled and making the State intervention the cause of the increase of private productive combinations, after an adequate period of time and by assessing the terms of the relationship including increments of collections, effects of public services and incomes for this reasons.

Economically, therefore, the decrease up to this point of fiscal pressure can mean a *positive* contribution by the complex State function, in the sense of the expression by the American Hansen (*leverage*), that is to say, of the development of the activity by private individuals.

Again through the interpretation of the symbols, it can be said – generalising to understand the economic meaning of [II] – that overall private income becomes a dependent variable,

$$r = f(t, s, v)$$

that is to say, a function of: 1) tributary collections and other forms of financial activity that give rise to fiscal pressure in a wider sense, with all the facts of the redistribution of purchasing power; 2) the diverse productivity of public expenditure over time.

II) THE FUNCTIONAL DEPENDENCE OF THE NATIONAL REVENUE FROM THE MANAGEMENT OF MONETARY QUANTITIES COLLECTED AND SPENT BY THE GOVERNING CLASS FOR THE STATE.

An appropriate combination helps to see in these arguments, as in the Keynesian concept, revenue as a dependent variable, in its overall quantity, that is to say, a function of the management over time of quantities of purchasing power on the part of the State (collection and expenditure) through what in section X of the *Introduction* we called *fiscal policy*, placed at the service of a policy, for example, of full employment of productive resources. (In this sense I wrote in the essay: E. D’ALBERGO, *Les problèmes de l’économie financière traditionnelle et la théorie keynesienne [The problems of traditional financial economy and Keynesian theory]*, which summarises in the “*Revue de science et de législation financières*” [Financial science and legislation review], a lecture given at the University of Paris.) That is to say, fiscal pressure is seen as a traditional notion and phenomenon,

in the context of the mass problems that polarise towards the “national revenue” variable, to which modern economic theory makes systematic reference, through the study of the effects of public expenditure collected in the forms expressed above: collection of tributes, issuing of loans, issuing of currency on behalf of the State, etc.

In 1933 I considered the effects of the financial management, including on the approaches (inclinations) of members and groups of the community from which purchasing power is subtracted and conferred each time, over time, with regard to the recourse to taxes and loans, already then with the meaning that they later took in Keynes, in the current sense. That is to say (as mentioned in section X, already quoted, of the *Introduction*), in terms of inclinations to consumption and to savings, to bring about the repercussions on income as dependent a variable, whose increments directed the solutions to employ taxes to cancel loans.

A complex set of effects, appropriately analysed, as pure financial theory allows in reference to the mass problem that is approached when discussing fiscal pressure, *may lead*, over time, to an increase or a decrease or to the stability of national income. The first possibility (increase) can occur when fiscal pressure changes its sign, in the sense that the numerical value of $(T + t + S + s)$ is more than compensated for by $(V + v)$, or when the stimulation to production overcomes the obstacle caused by tributary collections and other fiscal procedures. These, considered in isolation, can probably reduce production, in the same way as public expenditure can increase it, especially if it uses resources previously *hoarded* by private individuals.

However, it is not possible to draw conclusions in a necessarily *univocal* way, in discussions in monetary or objective terms, in the way that is required by the theories that apply the so-called multiplier, famously introduced in economic science by Kahn, used by Keynes and others in later literature, as I believe the readers of this course of finance are aware.

Indeed, it is necessary to proceed, in an *adequate period of time*, to the possibly separate analysis of the special effects imposed on the overall income variable, through the complex procedures of production and distribution, with corresponding variations of quantities consumed and saved, influenced by the different instrumentality of the State function, etc.: effects that in this chapter cannot be analysed but that have been and will be further illustrated in this course, in terms of the choice of fiscal instruments. Adequate conclusions are not necessarily those univocally and aprioristically drawn from the mechanical application of the so-called multiplier, which in itself does not shed any light with its automatic arithmetic action, which disregards the diverse sense of the repercussions that the financial event can cause on the entire market, in an adequate period of time.

Not only, therefore, as Borgatta points out, has the so-called theory of the multiplier or the theory of the utility of the increase of State expenditure confused the problems of the two phases (monetary and economic) of the effects of public expenditure, pausing on the first in particular, but also, in my view, it has too mechanically drawn conclusions in a *univocal* way, because of the increase in overall income, even when there is a *neutral* redistribution of purchasing power without the desired effect on income (increase), and without demonstrating in which circumstances and conditions the “national income” dependent variable is a function of the financial activity considered in terms of the effects of procedures of collection and of the redistribution of purchasing power even through public expenditure.

From this point of view, an appropriate vision of the problem such as has been offered, above too simplistic formulae and symbols, by the theory that derives from classical approaches (in contrast to Keynesian ones) of financial problems, would not have had to try so hard to exclude economic logic from the claimed statement, which is an unfounded “a priori” theory, according to which public expenditure, financed also with tributary collections, would lead to an increase in income (inclusive of State services) to an extent exactly equal to the amount of public expenditure!

Between the mechanical utilisation of formulae and the reasoned vision of alternate possibilities there is a logical chasm that persuades us not to take into consideration theories such as the one mentioned above, which has been discussed and refuted in various ways²⁷⁰.

²⁷⁰ Among other things, see what has been published in “Rivista Bancaria” [Banking Review], in Italy in 1950 and 1951, by Villani, Federici, Parravicini, Gola and Selan.

Returning to consider from this point of view – of Keynesian-type thinking – arrived at by making use of the propensity to consumption and to savings, in the technique or mechanics of the “multiplier”, it has *not been demonstrated that the expenditure of a given amount of tributes* collected from the market has necessarily as an effect *an increase* in the overall income. *a)* So as it can be demonstrated that tributary pressure *can* remain unchanged, formulating *one* of the possibilities indicated above, *b)* similarly it is possible to *highlight* (with the warning – which is not something Keynesian thinkers do – that this is *one of the possible solutions* to the problem of the effects of public expenditure, also in current models) that income, when collecting and spending tributes, can remain unchanged in monetary terms, even when introducing in the procedure the “mechanics of the multiplier”, which I will make brief reference to shortly, presuming this vision in the explanation of the effects of public expenditure to be known, following a theoretical Keynesian-type approach.

I will limit myself to recalling the meaning of (*PMC*) marginal propensity to consumption, as a relationship between the increase in consumption and the increase in the income to which the first is correlated; the marginal propensity to save (*PMS*), by a known logical complement is in fact $PMC + PMS = 1$.

Let's presume $PMC = 2/3$ (and that, therefore, $PMS = 1/3$). Let's formulate the hypothesis of an investment of 1,000 monetary units; according to the “multiplier theory”, there will be a corresponding increase in monetary income for workers employed in a given activity, which we presume to be a “public” one. If their marginal propensity to consumption is $2/3$, as presumed, they will spend 666.66 units on new consumption goods, so determining a corresponding additional revenue for producers of these goods. If they, in turn, have a *PMS* of $2/3$, this will give rise to an expenditure amounting to $2/3$ of 666.66, or 444.44, and so on, according to temporal succession of “production periods”. These periods, for example one year, can in practice be two, three or four, depending on the production area stimulated by the destination of the purchasing power created by the primary investment or expenditure.

(At the same time, alongside this series of mechanical repercussions of consumption, which give substance to the “multiplier” principle or technique, there will be, as is known, a series of investments in instrumental goods necessary to the new production of consumption goods, according to the “acceleration” principle, as it is called in current theory.)

Pausing on the action of the “multiplier”, we can define this as the numerical coefficient that demonstrates the extent of the increase in income, due to an increase in investment (in the case of public expenditure).

Given the series above, some numerical values have been highlighted; it results in successive terms also in a temporal sense: $1 + 2/3 + (2/3)^2 + (2/3)^3 + \dots$, whose *sum* is equal to the ratio between the first term of the series (that is, 1) and the surplus of 1 out of $2/3$ that indicates the *PMC* (in our case, therefore, $PMS = 1/3$).

We will therefore symbolically define as the multiplier the ratio:

$$\frac{1}{1 - PMC} \quad \text{and numerically, in the example, } \frac{1}{1 - 2/3} = 3$$

That is to say, the secondary consumption of 2,000 units is added to the initial investment of 1,000 units. The higher the numerical value of *PMC* is, the greater the corresponding variation of income that derives from it is.

In the geometrical expression, if we indicate the investment (and the savings) on the y-axis and income on the x-axis, tracing a straight line that represents the propensity to (marginal) savings (*PMS*), taking into account that it is $1/3$ in the example, that is to say, the increase mechanically corresponding to the increase.

From this we deduce that, when increasing the investment by 10 units, in other words, moving the straight line II to the ordinate of the straight line I'I', which indicates the change in investment from 10 to 20, we obtain an increase of 30 as income measured on the x-axis, while savings result, in correspondence, equal to the investment = 20.

This is the “multiplier” mechanism, disregarding the origin of the sum initially spent or invested, which is the same thing, and disregarding the consideration as to what might be the effect of a tributary collection equal to the increase in income from OR to OR' .



Figura 70.

An alternative representation has been used for this, showing consumption, investment equal to savings, and income. The straight line with a 45° angle indicates the inclination of I . Therefore, let the line that represents consumption have an inclination less than I , and from the difference we obtain the inclination of the line that represents savings.

Let's follow, for example, Samuelson who adds public expenditure in measure SP (P being on the line gg that indicates public expenditure), in Fig. 71, where income OR , consumption RC (C is a point on the line cc of consumption) and private investment CS (S is on the line ss of investment = savings). Let the effect be that of raising income from OR to OR' , on the x-axis (referring to Fig. 70, income increases from 170 to 200).

Let's presume the intervention of a tributary collection, in the measure of 30 units (of the 200 that correspond to OR' in the alternative Figure, as represented), that is to say, to the same extent in which public expenditure, acting as private investment would, had increased it (from $OR = 170$ to $OR' = 200$). What is the effect of the imposition on public expenditure? According to those who use, like Samuelson does, the “multiplier” technique, this effect would translate into a lowering of the consumption line. That is to say, the simultaneous consideration of the tributary collection and State expenditure neutralises the effects of the “multiplier” on income and, in this example, leaves the income level unchanged. Indeed, the “multiplier effects” that *could, in some circumstances* of the cycle, be found in the case of the State drawing from other sources (for example, collection of hoarded resources, additional increase in monetary means, etc.), in the sense of the increase from OR to OR' , *cancel each other out* in the case in which expenditure is preceded by a tax that reduces purchasing power and pushes the equilibrium point, which determines income, to the left and downwards.

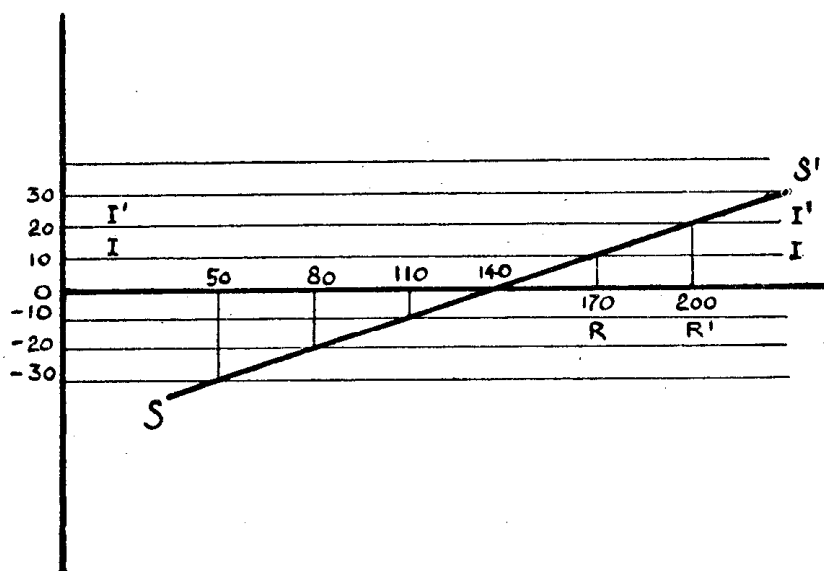
This lowering of the consumption curve, due to the tax, would lower the level of the overall equilibrium income by the same extent as that to which public expenditure had caused it to increase, because of the mechanical repercussion of the “multiplier”.

Let's turn the argument upside down: let's consider what the effect might be on collective income of a collection of taxes and of an equivalent expenditure, while still introducing the multiplier technique or mechanism. This is mechanically concluded in the sense that income remains unchanged

at OR , as it could be logically concluded through routes other than Keynesian theory, presuming tributary pressure to remain unchanged.



Figura 71.

However, after what precedes in this chapter, this is *not an economically necessary and univocal* conclusion; it is not so either in the sense of the solution, nor for the *quantum* of the variation, as there are, when they apply, very numerous “multipliers”, with different complex effects from income as well as from expenditure, in relation also to the numerous hypotheses that can be formulated on the numerical values corresponding to “propensities” [(PMS) and (PMC)].

Of course, in the same way as a reduction in tributary pressure can be translated in an increase in income, considering the effects of the collection on production *over time*²⁷¹ and on the distribution, as indicated above, it is possible to make a similar admission, when conditions favourable to the “stimulating action” of public expenditure occur, depending on whether it is supported by the collection of taxes, by taxation of hoarded resources or with a recourse to loans, in the distinct phases of the *economic cycle*. This analytical examination has not been carried out here, for brevity.

In the introductory pages, with regard to the function assigned to the financial instrument to increase employment and national revenue, among other things, I highlighted the possibility that the management of financial quantities could contribute to overcoming the “dead points” in the economic system dynamics, as a “auxiliary economy engine” – as considered by Taylor, who follows Hansen – in considering the State intervention together with *deficit spending* or even the transitory introduction of purchasing power into the market (*pump-priming*)²⁷². Among favourable circumstances, which Bresciani Turrone admitted (in his criticism of the multiplier mechanism, with paradoxical effects: in

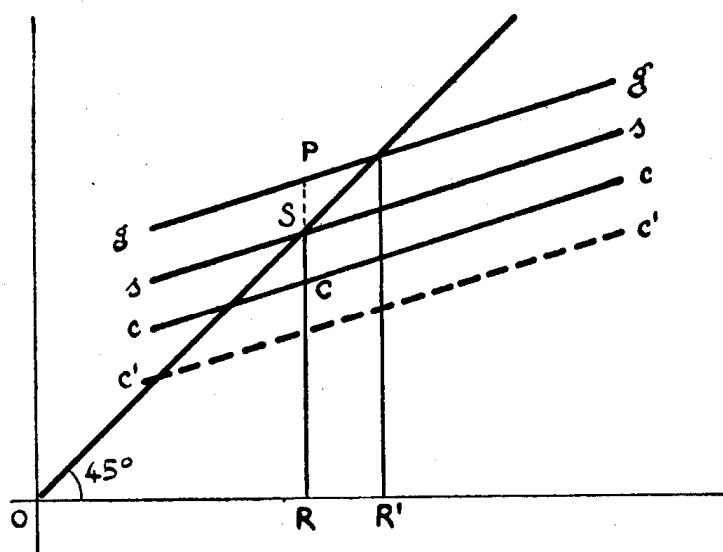
²⁷¹ The mode of expressing them was indicated in Chapter VIII of the *Introduction*, which deals also with the instrumentality of the State function, in the chapter on contributive capacity and, in several places, in the chapter on the economic effects of the imposition. I also refer the student dealing with this issue to the quoted essays entitled: E. D'ALBERGO, *Reddito e imposte - Saggio critico sul produttivismo nella attività finanziaria* [Revenues and levies – Critical essay on the productivism of financial activity], and *Discriminazione delle spese pubbliche indivisibili* [Differentiation of indivisible public expenditure], quoted. For the effects of collection and expenditure of compulsory social security contributions, see one of my essays, which might have importance from a general fiscal point of view, in “Rivista Bancaria” [Banking Review], 1940.

²⁷² These methods and relative effects on the entire equilibrium of an economic system, when they occur, will be considered analytically in another edition of these lessons: in part they can be gleaned from references in points β) and γ) of this chapter, and in the indications in Chapter X of the *Introduction*, which deals with fiscal policy, with Keynesian-type instrumentality, in relation to given quantitative characteristics of the economic equilibrium, as well as in what will be said about extraordinary finance.

“Rivista Bancaria” [Banking Review], 1939, to which I refer the reader), were the unemployed resources that are included in productive combinations and the action of the psychological factor (or psychological “multiplier”), when “the awakening of demand, due to the drive given by the State through public works, the decrease in stocks and a slight increase in prices, starts to filter through the entrepreneurs’ class the conviction that the depression is now over”.

This is not the place to continue to discuss a theme which must be considered to have been exhausted or at least adequately covered by the economic theory that I presume to be already known to the reader or student.

It was intended here to avoid an aprioristic criticism and at the same time all enthusiasm for the mechanical action of the “multiplier” expressed through formulae deceptive in their meaning, in contrast to the interpretation of the overall phenomenon, considered *over time*.

The time factor, to evaluate definitive or real or “economic” (in the meaning in which Borgatta uses the term) effects is so determining that Papi, in addressing the dynamics of tributary pressure (*Equilibrio fra attività economica e finanziaria [Equilibrium between economic and financial activity]*, Giuffrè Editor, 1942), adopts a rather long parameter, giving a concrete idea of it by using examples of five or ten years.

From this point of view even the conclusion simplistically inferred by Samuelson’s graphical demonstration could be a different solution, in comparing (a) the cost of the activity of the State as “producer of goods and services, promoter of works of social interest”, as Papi defines it, in the context of the hypothesis of closed market (cost that is translated in possible losses), with (b) the return of the same State action, as can be concluded observing an increase in income greater or lesser than the losses or the costs determined by the State action (income and expenditure) and their respective effects.

III) FISCAL PRESSURE IN SUBJECTIVE TERMS OF HEDONISTIC UTILITIES AND SACRIFICES.

Up to this point we have argued as if the consequences of the State financial activity are always and only translated into variations of objective quantities (monetary income), as advantages, against the burdens or costs of the same activity, expressed only in money. On the other hand, there are consistent advantages, for example, in terms of “patriotic pride”, of a sense of “protection”, of “new satisfaction”, as if, in the case of military defence, a new “consumer product” had been created and national income had increased. However, Ricci, who puts forward the example, abandons it (*La pressione fiscale [Fiscal pressure]*, etc.) because there is no practical way (intended objectively) to measure these increments.

However, in my quoted 1932 essay (*Sul concetto di costo della attività finanziaria [About the concept of the cost of financial activity]*, quoted), I highlighted how sacrifices, disturbances, etc., in subjective terms, should be added to the burdens of collection. Similarly, the disadvantages and the returns that take place through State expenditure are not always hypothetically, nor historically, translated always and only in monetary terms. There are services (order, security, military defence, education, health service, etc.) that are translated into ophelimities or utilities.

Hence, if we wanted to make the terms of the simple relationship that indicates tributary or fiscal pressure in a wider sense more homogeneous, it would be necessary to proceed, as incidentally noted Sensini (in writing in honour of Martello, 1917), by expressing it with the individual functions of (total) ophelimity or subjective utility:

$$\text{(gross fiscal pressure)} \quad \mu = \frac{\Phi m}{\Phi n} \quad \text{--- [IV]}$$

$$\text{(net fiscal pressure)} \quad \mu = \frac{\Phi m - \Phi' m}{\Phi n} \quad \text{--- [V]}$$

In his view, it would not be possible to extend relationships of the type in [IV] and [V] to the community, given the heterogeneous appreciation of individuals with regard to utility.

However, my vision of the explanation of the mass phenomenon that is expressed in public finance is also useful for the adequate explanation of each formula of fiscal pressure. I will not return to this vision because it has been widely illustrated and applied in previous chapters of this course and that necessarily dominates in the explanation of financial events, in which choices are interpreted by the governing class that homogeneously considers and compares, from its point of view, overall burdens and advantages of the financial activity, for the community. From this point of view, the objective or monetary quantity variations (formulae [I], [II] and [III]) and hedonistic-subjective quantities (formulae [IV] and [V]), can be simultaneously taken into consideration, homogeneously assessed also for the functional relationships that we have seen exist between the terms of the above mentioned relationships.

In other words, the insufficiency of the representation and of the explanation of tributary and fiscal pressure, *only* on objective data or *only* on subjective data, stops when they are subjected to the judgment that homogeneously fuses and harmonises the same data, completing their meaning. This judgment by the government can be tolerated, welcomed or approved by members and groups of the community for which it is formulated and historically translated in quantitative financial terms.

However, the logical process, in other words, the genesis of the judgment, allows us to take into account, in the mass phenomenon, in addition to objective data and immediately expressed in monetary terms, subjective or utilitarian data that *exist*, that are collectively determined, and that give content to the relationships that formally express tributary and fiscal pressure, as a result of the effects of achieving revenues of their distribution, in this field of State action.

It is a vision that claims to be new and to bring the discussion into the field of rationality appropriate to the study of the financial phenomenon, and was expressed by Prof. Lhomme (*La notion de justice fiscale [The notion of fiscal justice]*, in "Mélanges économiques" [Economic mixtures], dedicated to Prof. Gonnard, 1946).

I) From the collective point of view, given that the State distributes the sum collected in goods and services, nothing changes with respect to national income: what is subtracted with the imposition is added as amount spent.

II) This is true – he writes – for the overall national income and not for individual incomes, because the sums subtracted from taxpayers are not returned exactly to the same, as "citizens", beneficiaries of services.

He expresses himself thus, in short. Making the case for collection from the rich and distribution exclusively in favour of the poor, he finds that before the tributary collection (with RR as the income from the rich and RP as the income from the poor) we have:

$$RR + RP = R \text{ (national income);}$$

collecting taxes and using them in the mode indicated, we have

$$(RR - I) + (RP + I) = R$$

He concludes that what is of interest in assessing the fiscal burden or pressure (*charge*) is not the absolute amount of the collection, which according to him would leave R unchanged, but its distribution.

A) What has been expressed up to now allows us to correct this author's first proposition, stating the constancy of R , considering the phenomenon overall or from the collective point of view can be admitted in instantaneous and monetary terms. Over time, and considering the diverse productivity of the employment of basic necessities (in other words, excluding that there is an identity between the instrumentality of public services and the destination that, in the absence of the collection, private individuals would have directed the sums collected to), this can be generalised by saying that R could increase or decrease also for the community, considering the economic problem (productivity) that is hidden behind the monetary transfers of purchasing power.

B) If we consider individual cases, and we discuss the rich and the poor in terms of sacrifices and of enjoyments in a hedonistic sense, we return, as *equilibrium* of sacrifices and enjoyments brought about by the collection and distribution of them, to the concept of (gross and net) fiscal pressure expressed through utilitarian or ophelimity appreciations, as Sensini did.

Lhomme's vision, extensively also interpreted by me here, is not new. The approach to these problems in the present course of lessons allows us to overcome the criticisms that the same Sensini addressed to the shifting of the concept of fiscal pressure in utilitarian terms: indeed the hypothesis has been formulated that the governing class can have an idea of the sacrifices and enjoyments that State activity, as collection and expenditure, brings to individuals. This means that Sensini's objections gravitate around the field of the verification of the variations of quantities, not that of the theoretical concept of the variations of hedonistic quantities.

III) If, then, as Lhomme appears to want to express, through symbols that are indicative of variations of quantities objectively measurable, we want to refer to the *equilibrium* between collections and advantages for groups or individuals, the vision, which is both Sensini's and even better expressed (dynamic) in Borgatta), lends itself to absorbing the observations of the French academic. Indeed, what he says about the burden (charge) can be referred to as the pressure in objective terms as in the models that precede. These do not refer only to the community, but also to individuals. Furthermore, they overcome the strictly monetary and instantaneous (constancy of income) vision and rationally introduce the variability of *R*.

Of course, with this we criticise, necessarily following his argument, Prof. Lhomme of the University of Paris and those who have doubts and thoughts of this atomistic type, the financial problem being above all a mass problem.

However, because he contrasts the rich and the poor, just as has been done in the context of the distribution of tributes in the solution, precisely, of the mass problem, within the limits of the collection of tributes (theory of the proportional or progressive imposition), it has to be stated that the logical thought that guides this problem does not fail if the model is expanded until it includes simultaneously the sacrifices and the enjoyments of the taxpayers and of their typical groups, as they are seen by those who set this calculation for the community, in the hedonistic calculation carried out by the governing class.

The concept of equality to which arguments have been referring could, in this context (pressure), be said to be the *equal distribution of pressure* in terms of sacrifices and enjoyments, in the subjective field evaluated by the governing class, which considers collections and expenditure.

The same could be said of *equal distribution of pressure*, in objective terms, considering these arguments referring to groups and individuals (collections and advantages of expenditure and services), in the logical context of the theory of the relative contributive capacity, to which we refer the reader and in which collections in function of differential advantages, appropriate to modify the quantities included under the symbols *RR* and *RP* expressed by Lhomme, whose equilibrium in the mass problem is entrusted to the governing class, can be found.

It is presumed that in this context (fiscal pressure) and in the context of distribution of the cost of public services only, according to the meaning of the concept of equal distribution of pressure, the subjective and objective elements of the calculation carried out by the governing class result in being simultaneously coordinated, without contradiction, according to the theories expressed in this course.

II.

TRIBUTARY PRESSURE IN INTERNATIONAL COMPARISONS

The definitions of tributary pressure through the relationships where [point *b*) and *c*) of paragraph I of this chapter] the population factor is taken into account for the calculation of the same pressure, somewhat lend themselves, as has been said, to being used in those cases where it is necessary to compare different States from this point of view.

Until now we have argued, recalling the quoted authors, about hypotheses of a closed market, excluding foreign loans (that some authors take into account in the dynamics of tributary pressure)

and presuming that the incidence of tributes and other costly methods of obtaining incomes has taken place.

I) We often talk of comparative “fiscal” burdens, with reference to the pressure that tributary collections exercise in different measure in different States. Seligman, dealing with this by profession (*Oneri fiscali comparativi [Comparative fiscal burdens]*, etc., in Vol. IX of the Nuova Collana di Economist [New economists series]), warned that it is not enough to know the tributary charge per inhabitant, because “in a poor country and in a modest class of society, it can represent a much heavier burden than a higher average imposition per inhabitant in a rich country or in a richer class of the community”. It is therefore necessary to assess the *average income* per inhabitant. When the averages per inhabitant for both income and tributes are known, a greater approximation in the evaluation of charges (or of fiscal pressure) relative to the different countries can be reached, by comparing the *taxation per inhabitant* with the *income per inhabitant*.

However, this approximation does not yet correctly solve the problem of the comparability of the tributary burden in international relationships. It is necessary to consider other factors, such as, for example: *a)* the *composition of tributary incomes* depending on whether they are constituted by the revenue of indirect taxes, especially on individuals or on limited consumptions of the less affluent or general ones, in other words, by revenues of direct and progressive tributes on incomes and also indirect ones on assets, especially of the more affluent people; *b)* the *amount of income* that in the various countries must be used (as minimum for subsistence or for normal life requirements) for the *maintenance of the population*, an amount that would not have a contributive capacity; *c)* also the amount of income that must be destined for the *maintenance of production* without affecting or destroying national capital. These are elements that are difficult to calculate but whose importance has been considered critical, in particular by Borgatta, recalling statistical attempts²⁷³.

Factor *a)*, “composition” of tributary incomes, is intended in the sense that, at the parity of relationship between collection and income, indirect taxes that are not proportional to incomes but inversely proportional to them can determine a greater *sacrifice* of utility. This is the known shortcoming of taxes on individual consumptions, that is to say, those in which a percentage of income is spent that is greater for people with lower incomes and smaller for people with higher incomes.

I have lingered on this issue in paragraph VII of Chapter XI of this course, with conclusions that also take into account, among other things, the “effects of income” deriving from the differentiation of tax rates on consumptions (contrast of inferior or dispensable goods with superior or indispensable goods), as well as from the differentiating effect of public expenditure (to the advantage of poorer rather than richer classes).

It is clear that, at the parity of relationship indicating tributary pressure (for example, gross), tributes are mainly direct and progressive, that is to say, drawn with a collection from higher beneficiaries of income or owners of large estates, the sacrifice expressing the tributary pressure will be less.

II) However, from another point of view, the pressure of different tributary systems needs to be considered in terms of international comparisons.

It is known that historical examples have led to the consideration, including in theory, of the effects of the unification of markets, as a complement and sometimes a premise for political unification, in other words, in terms of common international politics directives, with constitutional repercussions for the orders offered by the Unions (such as the European one) that politicians talk about.

With regard only to the economic aspect of interest here, constituted by the influence or pressure of different tributary systems when markets move from separation to unification, both Italian and foreign theoreticians have advanced various propositions, even suggesting to “unify” taxation systems, to adopt the “same base” tax rate, or the same composition in terms of direct and indirect taxes, to “make uniform” or “align” tributary systems.

²⁷³ In *Appunti di science of finance [Notes on the science of finance]*, Giuffrè, 1933.

It has been considered, above all, that the unification of markets would cause the burden of *different pressure*, to the detriment of countries *A, B, ...*, with mainly indirect taxes bearing on production and on costs with repercussions on prices, which are increased by taxes, as this would prevent the sale of products from such markets or countries of origin, to the advantage of the other countries *M, N, ...*, that is to say, of those that have their own fiscal system, in terms of juridical and above all in terms of relative tributary revenue, based mainly on direct taxes on income.

I do not want to resurrect here the old question of the incidence on prices of direct and indirect taxes. However, provisionally accepting the proposition of the different pressure exercised on prices by systems constituted mainly by indirect taxes, I intend to restate the *indifference* of the factor represented by the different composition of tributary burdens in respect of the sale of products or goods that are influenced by them, when we move from various separate markets to a single unified market.

This is so where it is not forgotten that unification of markets does not mean the unification of currency or parity in terms of *monetary exchange*, so that it must be considered that price levels have *already* been influenced by various factors that determine them, including the fiscal factor.

It is necessary to demonstrate how it is indifferent for the consumer of identical goods, produced by a market in which the solution to the financial problem (tributary incomes) mainly involves the collection of indirect taxes (country *A*, which we can name as the national market) and by a foreign market, in which the solution mainly involves direct taxes (*M*): the indifference, in the context of the hypotheses that follow, is of interest mainly from the point of view of enterprises of country (*A*) that, according to the current assumption, would appear to be “damaged”. Fiscal pressure would translate into damage for the enterprises of country (*A*) because of the composition of the fiscal *system*, based mainly on indirect taxes: this assumption has been denied in one of my essays, from which I will quote²⁷⁴.

To give a sense of the solution, I have used a simplified model and, therefore, admissible only for ease of argument, with regard to the effects or the comparative pressure of different fiscal regimes (mainly: 1) indirect taxes on goods, and 2) direct taxes on income). I have considered the problem from the point of view of the capacity, *all other things being equal*, of enterprises from country (*A*) to resist the competition of similar enterprises from country (*M*), having admitted the solutions of the their fiscal problem to be in contrast to each other (according to the meaning of points 1) and 2) indicated here).

Where there is parity in the amount of tributes collected with the two contrasting fiscal systems, I have demonstrated the *limit case of indifference* for the enterprises that are presumed (by the theory opposite to mine) to be disadvantaged (country *A*) when we move from the “closed market” hypothesis to the “uniform market” one.

Let's presume, to simplify the issue further – after having excluded the destination of the tributary revenue in the compared countries and circumstances regarding the consumer's subjective equilibrium – that the law of variation of costs in function of the quantities produced by enterprises of the compared countries does not apply, *for the time being*.

Let's consider the consumer's income to be constant, with income *R*, with regard to the instantaneous hypotheses of prices along the demand curve *DD'*. (And *R - t* in relation to the curve *dd'*, *t* being the amount of the direct imposition).

Let's formulate the hypothesis of a flat tax, specifically *CT*, proportional to the quantity *OQ* produced and sold.

The enterprise becomes a collector on behalf of the State for the amount *TPpC*, which it adds to the intake *OCpQ* that supplies it with its normal income compatible with market conditions, which we presume to be those of (perfect) competition. Consumers, for example, national ones, belong to the State that has resolved the problem, pro-rata, choosing indirect taxes to a relatively greater extent, in a first hypothesis.

²⁷⁴ See the entire issue that arises for the historical case of the European Union, in the context of which the Italian-French union has been considered, and for the understanding of the dominant opinions that are refuted here, in a theoretical context, E. D'ALBERGO - *Il fattore fiscale e le unioni economiche* [The fiscal factor and economic unions], “Rivista di Politica economica” [Political economy review], January 1950.

Let's now formulate the hypothesis of a consumer in a national market and also the other hypothesis, that the State has resolved the tributary problem by resorting mainly to the application of direct taxes on income.

Economic theories, in particular in a dynamic context, recognise the functional correlation between the extent of the available income and the trend of the demand curve. The theory has also dealt with static curves but refers to *different time periods*. In our case, assuming the psychological approach of hedonists to be unchanged, we have different demand curves, in function of the different incomes.



Figura 72.

If we had

$$OQ = f(R) \text{ and } OQ = j(PQ)$$

we now hypothesise

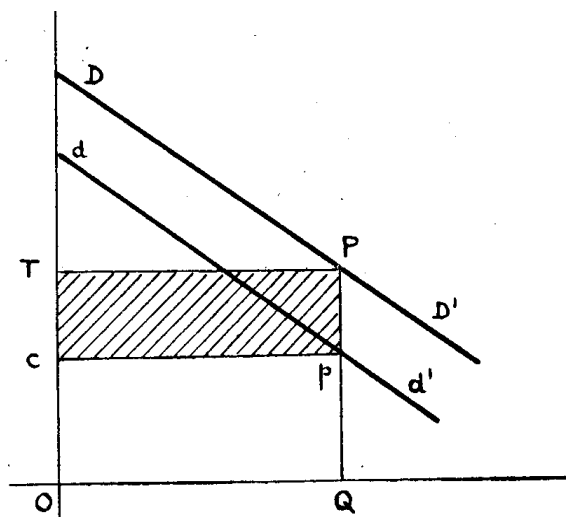
$$OQ = f(R - t) \text{ and } OQ = f(pQ)$$

with t as the sum of direct tax (equivalent to the indirect one) that has decreased the income to the point of lowering the demand curve, in the limit case, so as to be able to purchase the same quantity OQ with an expenditure equal to $OCpQ$. That is to say, such as that it allows the enterprises making the supply on the market the same *net of income* profit (with tax equal to $CTPq$, which in the first hypothesis the enterprise had collected on behalf of the State and transferred onto consumers) which allows it to remain on the market by obtaining a normal income.

In other words, and if it is legitimate to return from this rather limited model to the explanation of very complex events, it is *indifferent* to the enterprises operating on a national market to sell to the taxpayer-consumer that belongs politically to the State that has a fiscal system based mainly on indirect taxes or to the one who belongs to the same State that has resolved the problem by using mainly direct taxes. In both cases the *purchasing power* removed by the State leads to the same *net* economic result in terms of returns for the enterprise operating in a national market (after excluding the sum that is destined for the State).

Let's now presume that the *international unification* of markets takes place. Let's follow the hypothetical behaviour of the consumer-taxpayer that has been subjected to, as a foreigner, the mentioned solution (M) to the fiscal problem, contributing in percentage terms to the same extent in which, in national currency, the national taxpayer, whose purchasing power has been reduced to $R - t$, had paid the direct tax. If the income were to be expressed as though there were parity in the amount in the *national currency* of the market (presuming it to be A) that adheres to a regime of unification, the quantity OQ would be demanded [as $OQ = f(R - t)$] for the price pQ . And the national enterprise (A), also offering on the unified market, would not be able to pass on the indirect tax (which, by

hypotheses, affects the production in A relatively more), that is to say, the price PQ to the foreigner consumer belonging to country M . A similar conclusion would be reached if the income of the foreigner were, as it is normally, expressed in foreign currency and *exchange was equal*.

However, if we formulate the hypothesis of an exchange ratio tending to 1:2, the *foreigner* taxpayer-consumer, who has been subjected to a fiscal system mainly based on direct imposition in his own country (M) because of the juridico-political system in force there, is nevertheless left, after having paid this tax, with an income in national currency whose purchasing power given in the hypothesised exchange ratio *is equivalent* to that of the *national* taxpayer-consumer having income R . Therefore, the foreign consumer-taxpayer can, once the market has been unified, bear the price PQ and purchase the quantity OQ , without putting the enterprise in the country, in which the system of indirect imposition on production and consumption applies, at a disadvantage.

In respect of the enterprise of the country with a fiscal system of type (A), which, after unification, must continue to collect the sum $CTPp$ on behalf of the State to which it politically belongs, it is *indifferent* selling to the *national* consumer-taxpayer with an income practically untouched by direct imposition or to the *foreign* taxpayer-consumer with income already decreased by the main direct imposition. Because of the levelling of purchasing powers due to the hypothesised exchange rate, the enterprise offering the same goods on the unified market find itself dealing with a demand curve DD' in the *geometrical representation drawn for the hypothesis*.

The argument that has been simplified to the extreme here, as if it were legitimate to introduce the *all other things being equal* concept, just when a wider breadth of vision of the general equilibrium must be assumed, intends to give a rough idea of the sense of the solution of the problem of the indifference of the position of taxpayers-consumers, an indifference that is in practice probable when dealing with foreign consumers (country M) with a higher *average* income.

With this restriction, however, this argument may be useful to clarify ideas in the case in which there is a rather *uniform* average influence of the fiscal factor (indirect imposition) that, added to economic prices, determines the general level that, in turn, influences the international exchange, proportionally.

It is clear that for manufacturing taxes on products taxed in a highly differential way and for cases of differentiation against co-called luxury goods, a differentiation that is noticeable in common consumption taxes or in the tax on incomes from assets that give substance to "superior" consumption, it is possible to determine movements from the conditions, here simplified, of *indifference* for the buyer and the seller, when we consider the hypothesis of the unified market. Let's consider that the foreign consumer (within the limit of his budget) does not acquire *all* the products that by turning to national producers (country A). He buys some from time to time, according to his own preference.

Therefore, it is not possible either to disregard the case of foreigner consumers (country M) who, in spite of the exchange rate in their favour or with monetary purchasing power that greatly levels out the difference in average prices, have found themselves facing *variances* from the average of the prices of country A , due also and in particular to the differential fiscal burden, which has made some purchases prohibitive at the corresponding prices.

The situation is different when we are dealing with people with higher incomes for whom the parity of the percentage incidence for the fiscal collection which is used in this hypothesis does not apply.

CHAPTER XVI

SOME PROBLEMS OF EXTRAORDINARY FINANCE

I.

*RATIONALITY OF THE LOGICAL AND METHODOLOGY APPROACH TO PROBLEMS OF
 EXTRAORDINARY FINANCE, DIFFERENTIATED IN TERMS OF DEGREE, ACCORDING TO
 THE QUANTITATIVE ASPECT, FROM THOSE OF ORDINARY FINANCE*

1) Following a widespread tradition, I dedicate also in this edition of these lessons a chapter to so-called extraordinary finance, which will not stand as group of problems in contrast, in a rational manner, to those which give substance to this discipline, when it has as its object mainly the financial activity of aiming to satisfy public needs that are ordinary or that recur with greater frequency.

Mainly from an historical point of view, the extraordinary event represented by war is worthy of particular notice, as an example of circumstances that imply the exceptional and relevant, in a given sense, of the financial activity of the State that satisfies the public need that, in the specific case, consists of the military defence of national interests. Other events can give rise to an exceptional extension or increase of public expenditure, in specific periods of time. However, when dealing with war, which mobilises all willpower and energies and, in the material sector, induces the search for means of economic and financial policy appropriate to limit the satisfaction of civil needs in order to provide more effectively for military ones, it is necessary to legitimise (also in the notes that give guidance for the preparation of students) a part of the study of the transformations that financial activity undergoes in relation to the event here hypothesised. It is a subject that also finds space in treatises with chapters on “extraordinary finance” that, above all, in the past have had as their subject the problems of public debt in its various technical forms and in the alternative with the extraordinary tax.

In the case of the last war some observers of economic events, who were influenced by the historical event, believed to have found new elements both in the ideas that directed the management of economic forces (for the purpose of supporting military forces), and in the technical means employed by the management of the factors that play a part in war. From this derives the claimed “novelty” (in the sense of the “logical autonomy”) of the theoretical problems of extraordinary finance.

In the field of ideas, if a comparison is made with those that directed the events of the First World War, we find that not only the experience of that conflict but also the social upheavals that have taken place in some countries have led to the development of the concept of general mobilisation of the forces that fed the war. A programme of adaptation of the energies available to a country in all fields to the military event, through the current expression of “total war economy”.

I would not say, as some zealous authors would, that there has not previously been the idea of the need to adapt all economic forces to the exceptional case in the life of people represented by war on the part of politicians and academics. The experts of the theory of economic and sociological equilibrium could certainly have set the war event, in their models, as a cause or determining factor that transforms the approach and the operation of acting and efficient forces, with respect to the objective of increasing the supply of instrumental goods and services for war, so as to adapt it to the extraordinary demand made of them by the State.

If anything, the idea of solidarity between the forces operating in the context of the State has given rise to new *organisational* forms and psychological attitudes particularly adapted to the mobilisation of national forces, with regard to the historical case of war. *Technology* has also achieved, in rival parties at war, an approach informed by this point of view. In fact, in the field of production of instrumental goods, procedures have been adopted that have allowed almost no interruption of the continuity of production plans, in the passage from peace to war economy.

In directing economic forces towards the exceptional requirements of war, with a unitarian vision, the means used by the State are merged by taking into account the relationships of causal

interdependence and of aggravating causes with respect to the effect (which is the objective) to replace peace consumptions with the consumption of typically instrumental means for war. The means and instruments used to implement war “economic” policy end up including also those of war “financial” policy.

In the context of total war economy, according to some, the *antithesis* between economy and finance and between private and public economy becomes blurred. That is to say, the attenuation of the “dualism” between private and public economy, between national and State economy, between war economy and war finance, is a consequence of the progress that has been achieved in the conception of total war economy.

In the light of theory and of history, in truth it would not be possible to speak of an “antithesis” previously existing in these sectors, and it would not be possible to speak of dualism either. Considering the position of those who have systematically studied financial economy, we find that even those who could be viewed as “liberalists” have put forward logical models, in which the passage from economy of the nation to that of the State, which can be said to be equivalent to the passage from the satisfaction of private needs to that of public needs, took place under the drive of the relative intensity of needs, according to natural choices of the beneficiaries of income. The model that is normally called sociologic – but which, as I have demonstrated since 1932, represents a mode of necessarily approaching a theoretical mass problem such as that of financial economy – has later become more representative of reality: it has done so by keeping in mind the existence of a governing class that implements the calculations of maximum utility *for* the community, but without giving rise to the *logical* juxtaposition that can justify a corresponding theoretical “dualism” for the sole comparison between destination of income or wealth and satisfaction of private and public needs, respectively.

Neither does the existence of a dualism between war economy and war finance, that has been identified in the past, appear to be sustainable. However, even then there was *adaptation* both of the economic organisation and of the financial institutes to the war event. It is something else to say that this adaptation, from a *technical* point of view, or from the point of view of its actual realisation, can be implemented more rapidly and with fewer frictions in countries where the idea of national solidarity has had an influence, in time of peace, on the organisation of the forces acting on the market.

The same considerations apply to what relates to the modes and degrees of the “merger” between economic policy and war finance.

2) It is of importance to me, in this context, to state that there is not even a *logical* separation between “ordinary” finance (conceived as a science and as a set of facts relating to the activity of the State when it satisfies ordinary and normal needs in peacetime) and extraordinary or war finance, to mention the main, not normally recurring, event.

It is also in this case a matter of transformation or substitution or adaptation of the objectives of the financial activity when having to consider the variation of needs in terms of their *degree* or above all in terms of their *intensity* (quantitative element), also at the *time* when they occur.

To the *quantitative* fact (extraordinary income) then corresponds a *technical* specification of means, in the context of economic and financial policy. However, logic, which presides over the events of transformation and substitution of objectives and of needs, does not require a change in methodology and scientific vision, even in the case of the so-called total war economy, which mobilises all useful resources for the purpose of war.

Reading through previous treatises and, in particular, the one Einaudi (*La finanza della guerra [War finance]*, 1914) wrote on this specific subject, we see that war finance represents an *aspect* of public finance. When the author believed that it required a “different” treatment from that of ordinary finance, he was probably making reference to the theoretical conception in terms of novelty or logical autonomy of scientific problems, rather than the diversity of the real institutions (technical aspect) that are implemented because of the exceptional need represented by military defence in wartime.

However, in revising this particular approach in *Principii di scienza e della finanza* [*Principles of the science of finance*]²⁷⁵, the same author, who refuted the above mentioned proposition which might lead to the rise of a logical doubt, makes it a question of *degree*; in the sense that (some) public needs become *very intense*, require *greater* means (revenue) than those that are sufficient to meet ordinary or peacetime expenditure (if we formulate the contrary hypothesis, that of war, as a typical example of an extraordinary or non-recurrent need).

Similarly, De Viti De Marco compares ordinary expenditure, or ordinary requirements, with extraordinary requirements (quantitative element). He generalises to the point of disregarding the cause or the objective of the extraordinary expenditure, stating that the problem of extraordinary finance arises out of the different *quantity* of expenditure (an issue of degree).

It is recognised, also by those that present a new conception of total war economy in the theoretical field, that essentially there is no new *logical* problem when we move from the consideration of ordinary to extraordinary finance; where innovation is implied, it is of organisational and technical character.

For the rest, even in the context of war economic policy, there is space for the financial *aspect*. And there is a contribution to the realisation of the premises of war economy through *traditional instruments*, that is: the *issuing of banknotes, loans and taxes*. This is stated precisely by those who suggest the existence of a “dualism” in the preceding conceptions of relationships between economy and finance.

Therefore, it can be said that the organisational or technical vision that, more effectively than in the past, lends itself to the realisation of the solidarity of economic forces for the service of satisfying an extraordinary need of the community organised by a State does not change the *scientific* position of those who study the logical relationships of the means with respect to the objectives. Given that it is above all a matter of degree or of quantitative limits in which – at the instant or over gradually measured time – the means through which revenue is obtained for the State are removed from normal private needs to provide for exceptional public needs, I don't believe it is necessary to greatly modify the disposition of the subject in the teaching of the science of finance.

Therefore, after having discussed, in the first part, the financial activity such as it is used (expenditure and revenues) to satisfy *ordinary*, or normally recurring, public needs, I will follow with a section subordinate to the hypothesis of an intensification of some public need and, in the specific case, I will make the hypothesis of the exceptional need represented by the defence of the nation at war, to illustrate the modifications that the hypothesis involves in the sector of the search for means suitable to provide for the extraordinary requirements of the State. Of course this will be done keeping in mind the entire transformation that takes place in the economic movement in relation to war, above all in the sense of the temporal adaptation, such as it is considered by those who have dealt with the subject of total war economy.

The sequence included in the course of examination, therefore, corresponds to a logical order, in the sense that the part having as its subject the study of the *extraordinary* financial activity follows that which has as its subject the study of *ordinary* financial activity.

3) This type of warning, which appeared in the 1942 and 1944 editions of these lessons was reconfirmed in 1945 (in the essay by the title of: E. D'ALBERGO: *Prestiti e imposte nelle nuove teorie e nell'esperienza bellica* [*Loans and taxes in new theories and in the war experience*], “Studi dell'Istituto di scienze economiche e statistiche dell'Università degli Studi di Milano” [Studies of the Institute of economic and statistical sciences of the University of Milan]), that is to say, in the sense that “extraordinary” finance is differentiated from the “ordinary” one mainly in terms of *degree* (*extension* of public needs, *increase* of expenditure and of revenues, etc.). Indeed, if the problems of concern to academics of the last generation, who had been observers of the events of the First World War, led to a “given” theoretical solution, this was rationally linked to the hypotheses that those academics took explicitly or implicitly into account. In the more recent case of 1939–1945, the fundamental problem of the “modes” of financing the war and of the “limitations” within which it is opportune to make recourse to them has been viewed above all in light of the *point of view of the*

²⁷⁵ 1940 edition.

State, acting in an *economy* totally (for example, the German case) *regulated* or largely *controlled* since the time “ordinary” finance applied, that is to say, before the war. The passage from peacetime economy to the wartime economy was either not felt or it did not display the *jump* that nearly everywhere else characterised the events of the 1914–1918 war.

In fact, we read: “There was no need for a fundamental transformation for the passage from the German peacetime economy to the one in wartime, but only a further development; there was no need to open new routes, but to follow the one already known”²⁷⁶. This statement, which followed the one about the construction, in the last few years before the war, of a production apparatus “nowhere near that of the past”, under the “guidance of State direction, which knows what it wants”, which subordinated civil consumptions to war ones, was in contrast with the “should be” of Possony’s idea. (It is known that this author “recommended”, at the time he was writing, free economy as the prerequisite of any rational military economy.) However, in an historical context, an economy, not just the German one, was inclined to follow a controlled or regulated approach.

In this hypothesis, the differentiation between ordinary and extraordinary finance cannot but be in terms of “degree”. Financing procedures acted in an economic environment that had already changed in times of peace or times when, generally speaking, recurring or predictably continuous public needs, and with minimal intervention of probabilistic factors, occurred. If we compare the approach to the problem of war financing implicitly presuming the hypothesis of a more or less regulated economy with the traditional one of individual or Ricardian type, clearly the procedures that derive from this can be technically different from those illustrated by our predecessors.

However, the differentiation is already apparent in the problems of ordinary finance. Having admitted this, the differentiation between ordinary and extraordinary finance does not matter, in respect of the extension of needs, expenditure and revenues other than from a quantitative point of view. The procedures of mobilisation of that portion of income and capital removed from ordinary and private needs can technically be the traditional ones (loans, taxes, monetary credit and equivalent forms). Hence Fasiani’s statement, for example, makes sense: “while the differences between economic laws of ordinary finances are profound and numerous, the differences in the respective extraordinary finances are much less marked”.

When this author – introducing a qualification for which we have not recognised the rational necessity – in considering the means to provide for abnormal needs to be limited (in terms of possibility of choice), essentially recognises them as those that characterise the economic-political life of the “modern state”, a converging statement can be identified in the study of the German author quoted earlier, who glorified the current controlled economy structure. Indeed, Muhs wrote that “in the course of centuries, if we disregard the elimination of financing through the devaluation of war money and bonds, nothing has changed in the fundamental structure of war financing, so that also for present-day wars there are three methods available: financing through taxes, loans and an increase in the supply of money”.

He continues by stating that “the formulation of the problem on the basis of the science of finance concludes with the search for which *degree* of these three methods appears to be suitable to meet the costs of war in the most opportune manner, and this from the points of view of both the State and the economy.

4) The importance I give to my point of view derives not only from having interpreted traditional views in this sense (for example, those of the quoted Einaudi and De Viti De Marco), but also from the belief that what I have reconfirmed applies also in the context of *current visions of* more or less *regulated or constrained economies*, especially for the methodology that requires the mobilisation of the quantities with financial instruments in the economy called “of total war”.

Borgatta’s words below (in the preface to *Finanza della guerra e del dopoguerra [Finance in war and post-war time]*, October 1945) are in contrast to my conviction: “I do not agree with the concept expressed by one of our most valiant young academics, Prof. d’Albergo, that it is more a matter of *differentiation of degree in the procedures* of normal finance of the regulated economies (an

²⁷⁶ So wrote Prof. K. MUHS, whose article was published in translation in the issue of 31 March 1941 of the “Notiziario Economico” [Economy news], of the Milan Savings? Bank.

hypothesis which is on the other hand extraneous to the conditions of many belligerents) rather than a *diversity* of financial problems; neither do I believe that it can logically be built in the limits in which finance observes and respects the principle of *balancing budgets*".

First of all, I do not believe that it is possible to assign the value of a theoretical principle to the balancing of budgets, which corresponds more to the obvious vision of the tendential correlation or to the *equivalence* over time, *over a long span*, of expenditure and revenues, which is of hypothetical interest, regardless of the practical limits of its realisation. Furthermore, I had expressed another *degree* question also with regard to market conditions (more or less regulated economies). This does not allow for the consideration of my hypothesis, in real conditions, as "extraneous", as Borgatta wrote, because my term ("more or less constrained") covers them all.

I refer the reader to Wagner, for example, the "supreme principle" of the "balancing of incomes and outgoings" where he will find (Economy Bibliography, Series III, Vol. 10, Book I, Chapter I, Section III) norms of financial or administrative art, without rational meaning, such as are required in an investigation of qualitative character. This already highlights the problem of *degree* that is for me that of the differentiation between ordinary and extraordinary finance.

At first sight the "new orientations" in the study of extraordinary finance, illustrated by Borgatta in the remarkable specific treatise, appear to go beyond the quantitative aspect that above all differentiates the approach to problems. In fact he intends to "consider the tributary and financial procedures not only in relation to the maintenance of the formal equilibrium between revenues and payments of the public budget, but also in relation to the significant unity of the objectives of the State action in a period of war or of critical economic situation". In fact it is true that "financial provisions have essentially an *instrumental* function, they are not an end in themselves, but *means* to achieve specific public objectives" and that "during the war the objectives of the State lead to a general regulation of *all* economic life". Having said this, I will make two observations:

a) with these statements, that in part characterise ordinary finance of modern States with a regulated economy, we extend the field of investigation that an instinctive as well as rational specialisation of the science has put in place. We move to economic and financial policy²⁷⁷, which is one of the ways to consider and to *apply* the conclusions of the studies of the science of finance to the examples of the extra-fiscal objectives seen in relation to financial events, as we have seen in Chapter X of the *Introduction*. However, in this way the problem – which I resolved in the sense of the homogeneity of theoretical problems of ordinary and extraordinary finance – is *annulled* or it is *ignored*, without confronting it.

β) However, remaining in the field of the economy of public finance, I believe that my point of view should be restated also in respect of modern theoretical visions. I have already displayed in the "preface" my scepticism with respect to the excess of theoretical ambition of the models that intend to explain mass phenomena, with exemplification of the actual phenomenon, going back to overall quantities. Deductive analyses, also referring to individual subjects and to atomistic-type hypotheses, are preliminarily necessary in the logical order for the approach and understanding of quantitative relationships such as those in the models and systems of equations that claim to encompass complex sectors of the market. We have seen in Samuelson's models, for example, in addition to loans, also the reduced, unchanged and increased taxes that appear in the hypothesis of markets influenced by the fiscal factor. The increase in fiscal pressure, the effects of tax reliefs, the effects of increases in taxes, these are facts and phenomena that we have generally considered, in the theory, in a logical context that is appropriate in the explanation of phenomena, whatever quantitative

²⁷⁷ This could not escape Borgatta who, recalling the "links and subordination of financial procedures in a strict sense to the economic and political objectives of the state of war", as they transpire from foreign literature, highlights the concept that dominates these approaches, in the sense of the weakening or the disappearance of the differentiation between public and private economy, "for which there is no longer reason for a separation of the science of finance from that of economy". The author, who sees the transformation of the science of finance, in this way, into a war economic policy, does not follow the trend, which therefore seems no longer appropriate to act as the differentiating element of extraordinary finance from ordinary one. See G. BORGATTA, *La finanza della guerra [War finance]* (Alessandria, Gazzotti Editor, 1945).

extension has been assigned to the hypothesised fact. The hypothesis of deficit budgets is implicit within the limit of tributary pressure or in tax rebates.

The contempt for those “models” that ambitiously claim to establish links between overall quantities is justified by their limitedgnoseologic and logical value when they claim to surpass atomistic-type analyses.

In any case, the logical strength of my ideas is such that the same Borgatta, systematically contradicting himself, sees facts and problems of war finance as being characterised by *degree* differences, at each step of his extensive treatise.

I will give an example, in his terms.

- (During the war) “the use of wealth for the purposes of war invests *a larger part* of the citizens’ income and *part* of their assets” (p. 21.)

- “A peculiarity of war finance is the *tighter* link between economic and fiscal action and each procedure that leads to continuously following economic alterations in their reciprocal relationship with fiscal results” (p. 22).

- “War finance should represent the *most* rigorous application of the law of maximum results with minimal costs” (p. 37).

- “At times of war, the State does not increase *all* taxes to the same extent: it generally limits the increase to certain tributes and it applies them in unequal proportions” (p. 44), most likely on the basis of the criterion of relative contributive capacity that I have illustrated in Chapter IV.

- “The problem of the choice between various methods and their convenient combination occurs in conditions of *urgency* and *necessity*, such as they are not found at any other period in the life of a nation” (p. 125).

- “The academic has the possibility to follow various procedures that come forward *with great significance* and in *exceptional dimensions*, to study their different effectiveness in relation to time, to compare the methods followed in different countries and their results ...”. Precisely for this reason war finance offers a model which is more than any other exhaustive and fruitful of analytical investigations of the phenomena of extraordinary finance (p.125).

- “The war determines (therefore) an *expansion* of the *current needs* of the community, to which corresponds a *variation* of the mass of goods actually consumed by the community” (p.131).

- “It is necessary to differentiate the *overall increase* of the needs of the national community from the variations in income consumed by the nation” (p.129).

- “The requirements of war goods may or may not exceed the income produced annually” (p. 182).

- “The principle that must be applied during war is *simpler* than that of the minimum sacrifice, and it is expressed in the sense that the tax must be regulated so that as to collect *all income surplus*” to the sum necessary for the maintenance of the population, to production activity, etc. (p. 184).

- “When war requires, in addition to the consumption of income *surplus* to the minimum necessary, *also* the consumption of real *capital*, the recourse to loans and inflation is inevitable” (p. 189).

- “In a first theoretical approximation it appears possible to provide for war expenditure only with taxes both if the war cost is within the *limits* of national income and if it requires the consumption of a *portion* of capital” (p. 193).

- “The trend for fiscal pressure to *weaken* rather than to *worsen* is an established phenomenon in wars” (p. 234).

- “A characteristic of the dynamics of incomes during the war is the *rapidity* as well as the *measure* of the variations of incomes and revenues. The *brevity* of time prevents the fiscal organism from following *immediately* or *rapidly* changes in incomes and values” (p. 239); with regard to the grade phenomenon for taxes on consumptions, see p. 249.

- “Among the financial problems that arise for taxes on consumptions during the war, are: I) that of the *limits* of collections of income surplus to the needs of the population; II) the attitude to achieving a *reduction* of consumed quantities, compatibly with war needs; III) the effects of these taxes on the amount and on the reduction of national capital” (p. 265). - “Pressure of taxes on consumption during the war *increases* to a *lesser* extent than that on direct taxes” (p. 269).

- “The *increase* of the tax rates of proportional taxes (in addition to the progressive one, p. 282) (or continuous on assets) is one of the procedures the State at war uses *most frequently* to collect a *greater* portion of private income and its surplus to subsistence” (p. 286).

- “There is the need to integrate and strengthen the *normal* proportional tax, with an additional *strongly progressive* tax for the *portion* of income not collected by the first” (p. 311).

- “During *normal* times the progressive tax is linked to the decrease in of the marginal utility of income. However, in the war tax system this principle takes a *secondary* place; it takes on the economic role of *limiting* consumption of income by absorbing the *forecasted surplus*” (pp. 312-13). It would have been better to say that it is a matter, in this case, not of the problem of how to rationally distribute tributes but of the application of these instruments, in any case rationally explained, to the objective of war economic policy.

- “In the historical examples progressive taxes play a *very limited* part because only in some countries these existed as a *normal* institution of the tributary system, which was made worse by the war” (p. 320).

- “In contrast with traditional theory (which, in my warning, is *static*), taxes on surplus profits can be transferred to consumers, with the prevision of subsequent *movements* in (dynamic) demand” (p. 353).

- “Taxes on surplus profits have a progressiveness based on the *objective* fact of the *surplus* of these incomes with respect to the *normal ones*”. (p. 383).

- “They represent an attempt by the State to re-establish generality and equality” (p. 390). The reader will remember that this example is alongside others in ordinary finance to give account of the concept of relative contributive capacity, in these lessons.

- “The *tax on capitals* has the purpose to provide *one-off* collections for war expenditure and consumptions that *exceed* the national product” (p. 433).

- “A characteristic of the tribute is the *concentration* of payments of the tax due in the course of one or few financial years, in a period when private income has already been *entirely* or *to a great extent* absorbed”. (p. 437).

- “In normal times, with public debt, the State remains *below* the *limit* set by subsistence or productive activity requirements which must be reconciled with the servicing of loans. The special conditions of war economy “allow an *exceptional* expansion of the debt with the need to “redistribute a *greater* portion of income” with the servicing of loans” (p. 578).

- “The monetary circuit can be defined as an *economic policy* that, given the initial expansion of means of payment, has the purpose of limiting its excessive increase by reabsorbing purchasing power to provide for further extraordinary expenditure (p. 606).

- He summarises that the conclusions of his theoretical analysis leads to the vision of a financial judgment based on criteria and purposes different from the truly financial ones applicable for the *ordinary* activity directed at producing continuous and permanent public services. The theory must identify these purposes and evaluate the attitude or lack thereof of the procedures practically adopted to obtain them, keeping in mind the *hierarchy* of needs (p. 641).

As can be seen from the conceptual exemplification, Borgatta *either confirms the differences of degree in financial phenomena or moves from economic and financial policy, totally agreeing with my logical and methodological point of view for all the problems of extraordinary finance in comparison with ordinary finance.*

For brevity, I will limit the number of quotations – whose significant number is justified with the warning that Borgatta’s is the most *exhaustive* theoretical treatment of extraordinary finance I know – from which we infer a differentiating element of extraordinary finance in the quantitative variation of the facts studied. I will not quote the extracts in which the “novelty” of problems in the *stricter* coordination between economic and financial procedures, with the *expansion* of the control of the economy, is more frequently identified. As has been seen, often it is a matter of modifying an hypothesis that *already* characterises the study of ordinary finance, in contrast with that of free economy and of the others that I have mentioned at the same time in this paragraph, to explain the sense in which one theoretical approach can be considered “novel” without it claiming to surpass previous, but nevertheless still valid and current, approaches in the science.

In the context of this statement of principle, the problems of the *techniques* relative to procedures through which are collected the means to pay for extraordinary public needs are highlighted. Also in this more limited field, it is clear that the “choices” of governments are not arbitrary but enlightened by economic logic. However, these are particular problems compared to the general one mentioned above: that is to say, of the greater intensity of the needs to be met and of the financial effort that this requires, compared to the case of the satisfaction of current and ordinary needs. The general problem is resolved in light of the theory that has been discussed in the previous chapters.

General theories, which we have used to shed light on the logic or the genesis of the entire financial phenomenon, keeping in mind the relative intensity of public and private needs, in relation to income or wealth generally available for their satisfaction, in particular find application in the explanation of extraordinary financial activity.

II.

THE INSTRUMENTS OF EXTRAORDINARY FINANCE – THE HISTORICAL RELATIVITY OF THEIR USE AS A SOLUTION TO THE CORRESPONDING REAL FINANCIAL PROBLEM AND SPATIAL-TEMPORAL EMPIRICAL UNIFORMITIES

1) The exceptional periodical need that most disturbs the normal progression of financial activity is represented by military defence on the occasion of an international conflict. For this reason extraordinary finance is often identified with *war finance*, as we have just seen.

The question that above all and first of all needs to be answered is this: given the manifestation of an event (for example, a war) that requires a significant increase in public expenditure in comparison with the norm or the continuous needs of the community, which *provisions* can be used to meet this extraordinary expenditure compatibly with maximum welfare or least cost?

From an historical point of view, beyond the use of current budget surpluses (resources that are too limited), there has been a recourse to the following means or the following sources of income to achieve the means necessary to meet the exceptional or extraordinary increase in public expenditure:

- A) *War treasury*;
- B) *Extraordinary taxes*;
- C) *Public loans*;
- D) *Issue of money*.

A) War treasury

The first method can be said to have been superseded by experience because, in those cases where it has been used in the past, it has proved inadequate for real needs, given that the expenditure in the specific case, for example, of a war, has become so extensive and such as to make the accumulation in peacetime of gold or securities for use in case of war completely inadequate. Or at least of very limited use if not at the *initial stage* of an event that, like war, requires extensive financial means.

Furthermore, because these may be portions of wealth removed from the economy, this method of “hoarding” sums for this purpose has been condemned as antisocial. If this reserve is made up of debt bonds, which would need to be sold at the time of exceptional need (public bonds, private securities), this would involve an operation with economic effects on the market not unlike – as we have seen before (Chapter XIV) – those of the issue of new loans, to gather up available funds for the exceptional and extraordinary public need.

Nevertheless, I have said that it is a method outdated *to a great extent*, because both theory and practice have led to the belief that the incidental and possible use of *gold reserves* of the issuing

institutions or of the “funds” for monetary exchanges is convenient and possible, these days, *without* earmarking them for this purpose.²⁷⁸

B) and C) Extraordinary tax and public loans

Extraordinary taxes, considered as an *exacerbation* of the existing taxes, have more relevant importance. These are, for example, the 50% increase of the Einkommensteuer tax in Germany, or the additional supplementary tax in Italy, or an adjustment of the tax rates of categories A) B) C¹) of the moveable wealth tax, the increase of the tax on “income”, etc., on the occasion of the last war, to name but a few of the more apparent increases; or the introduction of *new taxes* both on incomes or assets that are formulated in relation to the war event, if this is the most important event from an historical point of view. (These are not intended in the sense of “additional” new production events, but in terms of a redistribution of the wealth and incomes that war in particular generates, considering the community overall.)

The historical experience *did not* give rise to *constant uniformities* with regard to the recourse to extraordinary taxes to provide for exceptional requirements, for example war ones, considering the different States and the same States over time. In fact not all States gave significant weighting to the source represented by the taxes of the First World War, and in the case of the last war not all made recourse to it in the same proportions compared with the other sources of extraordinary income.

Of course, if in the first war the alternative of an extraordinary tax had a double effect, as it was an alternative not only to loans but also to the issue of banknotes, in the historical case of 1939–1945 the recourse to mainly *public loans* was in contrast with the extraordinary tax, as indicated in the traditional theoretical treatises, precisely to exclude “*a priori*” the recourse to banknotes.

Indeed, with respect to extraordinary public expenditure, there has not always been a correlated noticeable increase in the monetary circulation in countries at war. However, before making reference to spatial-temporal uniformities in the solution to these problems, let’s consider the theoretical explanation of the genesis of debt.

Generally speaking, public debt *arises* as the procedure that is *more economic* for the entire community than the recourse to the extraordinary tax, also taking into account the fact that the extraordinary tax is not enough to provide the necessary means to meet the extraordinary expenditure if it exceeds tolerable limits or limits that are socially prejudicial in terms of fiscal pressure.

Let’s presume that the extraordinary tax is conceived as a tax on *existing assets*. It is known that these are not homogeneous assets but are made up of land, houses, industrial enterprises, etc., in other words, wealth in liquid or mobile form. This is not all. If all those who own assets were to sell a part of them to meet the cost of the extraordinary asset tax, there would be many sellers without as many buyers.

Each owner, who has invested his wealth in accordance with his own “taste” (subjective value) might not have any intention of liquidating a part of it, which could, furthermore, in many

²⁷⁸ In the Italian case, since the time the war in Ethiopia broke out and a law removed from the Banca d’Italia the obligation to convert banknotes issued in gold (according to the stabilisation law of 1927), it has been believed that the reserves that were deducted from the monetary function could be used as a war treasury, that is to say, employed for the purchase of prime materials and other instrumental goods, on other markets, to strengthen the possibility of military action.

In fact, the policy that for some time was followed in Italy of crystallisation of gold reserves and their defence from the point of view of the monetary amount they represented was criticised, as it would have been convenient to transform them in prime materials or other instrumental goods that could be set aside for military action.

Abroad (in the United Kingdom and the United States), even though this totalitarian approach has not been adopted, to a large extent an *international* debt has been established, to provide for the large-scale purchase of *prime materials* essential for a possible war. These were purchases on the international market (cotton, rubber, metals, wool, etc.), which were defined as “strategic purchases” because they were directed mainly to the typical objective of a war treasury.

Of course it is the incidental and non-systematic methods (like the treasury) that can be deployed only within restricted limits to meet the exceptional requirements or the extraordinary needs that are typical in the case of military defence.

cases end up damaging the residual asset value in terms of its being a productive unit; and if the State were to ask for an extraordinary tax, it would be from those who De Viti De Marco calls “capitalists” (rather than “owners”): to ask them for the sum that the State requires in terms of extraordinary tax. That is to say, this would give rise to *a series of private loans* in the relationship between owners and capitalists, on the basis of many interest rates that might give rise to an overall amount, let's say one billion and 200 million, on a total of 20 billion in sums loaned (at the rate of 6%). Formally everybody remains the owner of the assets they owned before the introduction of the extraordinary tax of the relevant amount, but these assets are devalued in the measure of the annuity that the individual proprietors owe the capitalists who have lent them the sum to give to the State for the extraordinary tax, requiring an interest of 6%. That is to say, many pro-rata annuities that give rise to the sum of interest of 1,200 million on the entire market.

If, instead of doing this, the *State* were to renounce the extraordinary tax collected from proprietors and addressed the capitalists *directly*, drawing a *public loan*, it is very probable that the interest at which the sum is loaned would be lower than the average one that would have applied in the case of the series of loan relationships between private individuals. It is likely, therefore, that capitalists might be prepared to loan sums to the State at an interest rate of 5%, with a saving of 1%, which is a benefit to the community, in terms of a lower financial cost of the State activity to satisfy an exceptional need.

Public debt arises in this way. Of this, for example, De Viti De Marco in particular has illustrated the genesis with simple, clear arguments of the type I have reproduced here, with the purpose of interpreting events.

2) Given the two standard instruments of extraordinary finance (extraordinary taxes and loans), with respect to which the issue of banknotes is considered, in theory and in practice, to be a means of mobilisation of purchasing power and of capital assets, I highlight the theoretical *relativity* of the solutions of the financial problem, in relation to the hypotheses linked directly to history.

As I have incidentally mentioned, uniformities able to explain the events with a limitation of the validity of the theory (made up of empirical laws) over *time* and *space* can be based on the immediate observation of facts or on experience in the field of extraordinary finance.

With regard to the recourse to loans and taxes, theoretical laws have also taken rule-making form in terms of their expression as *normae agendi*, or as trend-provisional laws or laws limited over time in terms of the modes of financing war or an extraordinary expenditure generally.

It is easy to observe that an empiric uniformity, experienced in wartime, may not have value in a different case, because it is in contradiction and in any case not in harmony with new events. The same observation will be able to be made against financing systems believed to be of the “best possible” compatibility with the complex (economical and sociological) circumstances each time considered to be “current”.

The ones that follow are precisely empirical uniformities of limited spatial and temporal validity, which I introduce here as examples.

To limit myself to a few authors, I will recall the following positions with regard to the problem, quoting first of all those propositions that derive from the observation of past economic events:

A) The following aphorism could be read, for example, in Flora's writings, and keeping in mind at the same time both the temporal succession of the instruments for the financing of war and quantitative proportions, “good treasury practice prepares it, loans sustain it and taxes pay it off”;

B) Thinking in terms, most likely, of the prevailing of logical economic actions and a minimum of frictions and resistances that I will define as sociological for brevity, Einaudi so concluded an awe-inspiring chapter of financial history: “Italians would have, therefore, been able to fight a war without dragging loans, without monetary inflation, without increases or decreases in prices different from those that are inevitable in any passage from one productive direction to another and without serious disturbance to established positions if they ... had chosen to live for 10 years with an average standard of living only 86% better than that observed on the eve of the war for a farmer in the same country.” To give an indication of the financial instrument, he stated that the objective could have been reached if the burden of the conflict had been distributed through taxes arranged so as to

collect the necessary means according to the principles of progressive taxation having the objective of achieving the minimum collective sacrifice;

C) In perhaps too generalising a manner, in referring to the opinion in his view obvious or prevailing with academics, Gini²⁷⁹ thought he was expressing a preceptive uniformity, essentially empiric or drawn from the observation of the events of the past war more than from cases of ordinary finance when he wrote: “Everybody knows how economists ... have claimed that public expenditure must be met primarily with tributes, exceptionally with loans and never with the issue of banknotes.”;

D) To limit myself to the quote of the author of a relatively recent organic essay on war finance from abroad, I recall how the following appears in the pages of H. Jecht²⁸⁰: 1) the collection of tributes, as the “ideal” method, also in the view of other authors, for the financing of war; 2) the possibility in the past (1870) of only using loans.

To unfold a series of examples of norms or empiric regularities, in the recent case, I recall how the same German author indicated:

E) That the *limits* in which it is necessary to make recourse to loans, taxes and advances of monetary means (indispensable, in his view and in that of others, for meeting the “first costs of the war”) will depend – without being able to proceed to a determination “a priori” – on the actual circumstances, on the economic situation of the countries involved, respectively, in the war and on the character of the same war.

And the rather significant anthology for the particular approach to this short essay can be continued by recalling also the following extracts, which contain the so-called historico-statistical trend laws and inductions from observations reflecting given circumstances in terms of time and space;

F) The same Prof. Flora²⁸¹, in illustrating the trends in action in the last war, stated among other things with regard to the worldwide case: “loans in all their forms financed the conflict in the initial year (1940–1941). The function of notes and of tributes was simply complementary.” After remembering the Italian case, referring to official declarations and indicating that in the first fifteen months of war expenditure was met “five-sixths with loans, in other words, with national savings and for the most part with direct investments, and the remainder with the issue of banknotes and by ordinary and extraordinary taxes, in practically equal parts”, expressed the following uniformity: “Only public loans, by ensuring the general devolution of savings to war needs, can finance the war, rake in banknotes printed because of it in the initial stage and contain the exacerbation of tributes, at a minimum cost for the national economy. Taxes, which after a certain limit feed onto themselves, or the emission of banknotes for the treasury, which disturbs costs, prices and credits, cannot replace them. This is now the financial policy of all States at war, determined to avoid the inflation of the world war ...”;

G) The views of Keynes with regard to the financing of war are known, as are his social concerns, which induced him to suggest the type of “forced savings”, implemented through the taxation of incomes of the working classes, who could then be reimbursed at the end of the war for the greater fiscal contributions in wartime. (A system in part accepted by the legislator.) Irrespective of the restriction with which the recourse to taxation was suggested, Keynes insisted on the elementary function of short- and long-term loans, and he stated that, when there is no further absorption of available funds through this route, the equilibrium (between private and public consumption) can be obtained, as a last resort, by a higher fiscal pressure, which can achieve more than a high interest rate and which does not compromise future finances, by placing obstacles in the way of how the public buy what they want.

A “modus agendi” that in part should have directed the procedure of the “circuit of capital”, according to Keynes, should have been the following, as a norm for the emission of State loans: in the first place it is opportune that they should be issued after and not before the expenditure they are

²⁷⁹ *Patologia economica [Economic pathology]*, p. 3 of the 1935 edition (Milan, Giuffrè Editors)

²⁸⁰ *Kriegsfinanzen [War Finance]*, p. 56].

²⁸¹ Report to the Senate, No. 2214/A of 1943.

needed to cover, because it is the same expenditure that creates the saving used by the loans; it is then necessary to adopt the form of issue that is best appreciated by the public;

H) Making reference to the American case, characterised by a growing national income, Prof. A. Hansen, in examining the extent to which it would be opportune to make recourse to bank credit, to private savings and to taxes for the financing of budgets, excluded bank credit (typically useful in periods of deflation), expressing the following precept, correlated to the previously mentioned financial conditions. That is to say, financing should be made mainly through loans in which the savings made out of current income are invested, and with fiscal revenues. Tributary pressure should increase in relation to the absorption of the productive cycle of the national labour forces, for the purpose of exercising a limiting action on consumption through taxes.

This theory was opposed by Prof. Galbreith who, stating that inflation is possible even with a balancing budget, suggested caution in making recourse to taxes to fight inflation, given that their deflationary effects in the post-war period could lead to a burdensome system of taxes on consumption. The same Hansen's thesis was welcome by Prof. A. G. Hart who suggested a recourse to taxes and compulsory loans to absorb the purchasing power in excess of the increase in production;

I) Eccles and Prof. Sprague in the United States, discarding the recourse to bank credit, gave priority to the recourse to taxes both to absorb "excessive" purchasing power and to take account of the increase in the public debt forecast to be in very high absolute figures. Eccles' empiric norm extended to the specification that taxes (on incomes and surplus profits) "should" have assured the coverage of no less than *two-thirds* of war expenditure;

L) The relativity (in typical circumstances that will be generally listed later) of analogous precepts is noted also in German writers. Let's think of propositions such as the following ones, of the quoted Prof. Muhs: a) "The meeting of expenditure through taxes is recognised as the best way, perhaps ideal way, of financing war"; b) "if the State pursues the objective of meeting expenditure exclusively or primarily through taxes, the fiscal burden can easily go beyond the measure of what can be tolerated"; c) "therefore, generally speaking, there are limits to financing through taxes that are not, however, fixed but elastic and that, according to the State's political conditions, the wellbeing of the population and the requirements of war, can be more or less expanded but that must be respected in some way, if the State intends to comply with the hypothesis of maximum opportunity in the financing of war"; d) "when the maximum limit of taxation is reached, it is necessary to make recourse to loans to finance the rest";

M) Another expression of the historico-statistical trend law, emerging from the German press in the discussion of Benning's and Donner's ideas, is that which regards the classification in terms of the effectiveness with which the possible procedures contribute to the absorption of purchasing power from the market: the use of the tax and of similar provisions is in first place. However, this system has many limits and therefore making recourse to other instruments is inevitable. Again in terms of their effectiveness in achieving the objectives quoted above, for Germany their classification (after taxation) was: I) the forms of war (iron) savings for employees and entrepreneurs, restricted since the end of the war; II) long-term State loans; III) short-term loans in treasury bonds; IV) savings and bank deposit accounts;

N) For the purpose of the identification in this field of the divergence between the immanent concepts of the abstract being of the social structure (which the deductive science takes into account) and the entwining of the relationships of the abstract structure with the reality of things that dominates the type of treatises with an empiric background, the discussion between German economists with regard to State debt is no less enlightened.

It has been necessary in this regard to read uniformities of this type: a) "As far as State credit is concerned, it is also possible to demonstrate theoretically that there is no fixed limit to the increase in debt. In practice, however, the quantity would gradually degrade quality, giving rise to tensions in the social structure ...". "The amount of increase in State debt must be contained to the extent which is absolutely necessary to avoid later tensions in the social structure"; b) (on the part of Prof. Donner): from the point of view of credit technique, and the point of view of paying interest and reimbursing capital, there are no limits to State debt. A limit is marked by the quantity of goods produced that are destined for the State, after the satisfaction of the needs of the civil population; c) the thesis that might

seem paradoxical to the layman was explained by Siek, from a theoretical point of view, from which it is possible to understand how the possibility of paying interest is theoretically infinite. He contrasted this theoretical possibility with real limits within which the overall burden of taxes and the collection of specific tributes can increase, making reference to various and social economic influences. From this derives an indirect limitation of debt. Whatever this is, we will not be able to obtain this for a given country from the quoted German academics and generally from financial theory, as this is a synthetic or sociological analysis that goes beyond the scope of this discipline; *d*) Terhalle, making reference to psychological and constitutional criteria, believes the limits of State debt to be non-existent. He differentiates these from the limits of tolerability of the service of loans, stating that “for a State that controls the economy” (an hypothesis that incorporates all the constraints of the hypothesised system) there is practically “no immediate limit” to the possibility of taking out loans; this limit would depend, in the long term, on the effects of the redistribution of the income or of the wealth that would derive from the collection of taxes for servicing the same loans.

So as not to add to the series of opinions expressed by academics as “value judgments” or as precepts into which, in particular in the quoted extracts, empiric laws or uniformities can be translated, I quote analogous statements from figures in government:

A) An historicistic position quite appropriate to the solution to the problem was taken by Thaon of Revel, in Italy, by saying that war finance “cannot be founded on academic texts, but it arises and is developed with the needs that come from war life and it is suggested day by day by circumstances”. However, he distances himself from this, in part contradicting himself, by saying that the *parallelism* encountered in the financial provisions implemented by various governments with respect to objectives and means used, and their *contemporaneity and succession of use*, would have revealed an “absolute determinism to which finance war is subject, outside and sometimes in spite of classic economy”. This last statement, whose credibility from various points of view can be measured by those who have followed this *course*, ends up by assuming mainly the character of the recriminations of “practical” exponents against theoretical uniformities (not otherwise specified) to which they would like to ascribe the power to dominate facts. The sense of contradiction as well as the undetermined genericity of the solution to the real problem, which restates itself in all its historicity, can be found in the words: “war finance must, among other things, pursue a *harmonic distribution*²⁸² of the financial effort between taxes and loans”. However, no adequate ideas are offered about the elements each time or generally appropriate in the realisation of the sought-after harmony.

B) An absolute statement, at the beginning of the war, was that of the German Finance State Secretary, F. Reinhardt, who declared: 1) unlike what happened in the past war, the current need would have been met essentially through taxes; 2) there was no intention to make recourse to war loans until economic considerations led to finding them necessary; 3) no measures likely to lead to the devaluation of money would have been adopted.

In (February) 1940, Minister Funk confirmed that free purchasing power should be systematically absorbed through taxes and loans, avoiding monetary devaluation and the widening of credit without a corresponding increase in production. The same year Prof. Wagemann specified that it was intended to meet an expenditure of 50 billion marks through fiscal revenues for one half, and for the other half by making recourse to loans. It was hoped that it would essentially maintain that proportion, also judging by the intention manifested by Funk in 1943.

C) In the United Kingdom, the increase in fiscal pressure had the objective of ensuring that around 50% of expenditure would be met through fiscal revenues, which (according to declarations of the ministers in the first years of war) stood then at around 40% on average.

D) In the case of the United States, there was the declaration of the programme by the Finance Secretary, Morgenthau, in 1941, in the sense that he intended to meet, through tributes, 75% of the expenditure in wartime.

²⁸² Totally undetermined concept, in quantitative terms.

I will terminate here my illustrative anthology. The finance war historian in the future will provide treatises in which fragments of ideas, such as those expressed by theoreticians and government men, will be set in the fabric of events. However, what can be seen to be common in the uniformities inferred from the events of the First World War and linked to the Second is the attempt, not always appropriate and rationally conceived, to use the conclusions of theories abstractly based on hypotheses well delimited by the quoted authors, who have studied the problem of the financing of war or of an extraordinary expenditure generally.

The need for brevity, already quoted, induces me to neglect the quotation of the “*normae agendi*” derived from the analysis of the operation of the “circuit of capital”, an expression whose scientific meaning has been exaggerated and under which the programme of mobilisation of monetary availabilities and of the corresponding real assets are encoded, by making recourse to loans and taxes and limiting, to the maximum empirically possible (without any claim to mathematical precision), the recourse to the *additional issue of means of payment*. Similarly, I will not refer to the precepts that derive from the close examination of the limits within which, even though the quantity of circulating goods does not increase, it is possible to have an increase in the means of payment (associated with unused productive resources) without giving rise to inflation.

3) Observing the contrast between the preceding statements, compared with each other, and the lack of coincidence of the preceptive norms that they share with events, and even more so, observing the contrast between the pragmatic ideas expressed, for example, at the beginning of the financing of war and the behaviour implemented practically, we will not repeat the now forbidden criticism formulated by the laymen, according to which the war economic situation – as well as the economic crises – would have legitimised the “failure of economic science”, in other words, that political economy “laws” would have “led to bankruptcy”. Leaving statistical laws aside, however, it will instead be a case of perceiving, as has been systematically done in the preceding pages, that the preceptive norms that are necessarily revealed to be inadequate to explain all the facts in their changeable flow, are precisely those that are derived from the observation of *given events* and of *limited* experiences.

How can failure of the uniformities that were expressed with explicit reserve with regard to their limited validity, i.e. as empirical laws, be claimed? That is to say, when the constructors of such “laws” or uniformities of a spatial-temporal nature admit that a wider and more diverse experience can ultimately deny the law itself, whose validity depends on the conformity of the possible experiences to the experience already acquired ?

It is known that various authors have attempted to clarify the reasons that had led the laymen to solemnly declare the failure of economic laws and that an entire volume (in the case of Gini) has been written on the basis of the contrasts between the conclusions of theoretical economy on the one hand and the actual behaviour of governments and individuals in economic matters on the other. However, I do not believe that it helps to state that by economic laws the economist often means “the precepts that derive from the presumptions from which his theories start”, adding that they mean that “if the world had observed these economic precepts, things would have worked out better”. Indeed, the presumptions from which theoretical economists start are not precisely or not all or only those that determine real problems, in various historical periods and in various countries.

The preceptive norms that I have recalled at points *A)–M)* and *A')–D')* are definitely not the type of universal laws formulaated on the hypothetical basis of statistics. The first, as mainly empirical, are characterised by a relative validity, as I have specified.

In the specific case of observed lack of uniformities in the conclusions of academics and government men in respect of the solution to the problem of succession and of proportions, respectively, of the use of taxes and loans for the financing of an extraordinary expenditure, in the attempt to explain the divergence, the mind oscillates between old and new ideas; it is possible, for example, to trace, in V. Fuoco, the argument that economy resolves problems according to general principles and administration science (as the application of the same principles to the functions of a government) according to the same principles “modified” by the special positions in which a

government finds itself²⁸³. It is a rudimentary vision but appropriate to the time in which it was conceived. On the opposite side, however, are the more recent visions (of the dynamics) on which some authors have taken extreme positions, to the extent that it is possible to read contradictions in terms of expression and not in terms of concepts, such as that of uniformities, that are “*unique in themselves*”. When they appear to have been modified by the development of circumstances, it is indeed not a uniformity (a certain uniformity) that is modified but rather there is a “continuous construction of uniformity of nature” (Demaria).

In the particular problem of the financing of an extraordinary expenditure, such as that to be met to wage a war, the solution is not equal or uniform because the determining and causal factors act in different combinations and present neither qualitative nor quantitative uniformity even in apparently similar institutional structures, given the deducible diversity of those that have been defined (by Demaria) as “spatial-temporal coordinates”: I will limit myself to a list of causal factors. The relativity of historical series and empiric laws, which prevents the determination of a general classification according to the importance of the respective influence of predetermined factors, will be compensated by the length of the list and by the attempt to avoid gaps and repetitions.

4) Arguing about the *types* of circumstances, drawn from the examples of the last and the previous war, or identified in investigations by other authors, it is possible to compile the following meaningful list, with the objective of identifying the presumable reasons for the different recourse to loans and to taxes and to confirm the relativity or the limited validity of the empiric laws that have been articulated regarding this.

In particular from the point of view of the State and, respectively, of the community (the individual point of view being less conspicuous if not indirect and, in some hypotheses, negligible), it is possible to indicate the following circumstances variably identifiable in time and space as factors constraining empirical trend laws or the choices of government men: 1) The race to armaments, already in the pre-war period, was supported by increasing public debt, so that a war economy was forged in peacetime. 2) The extraordinary financial (or especially tributary) effort started before the war (in the Italian case about five years earlier). 3) During peacetime the economy was dominated by the war spirit (Germany), for this purpose modifying the legislation on the issuing banks and regulating prices, salaries, interest, etc. 4) The diverse degree of control of the economy influences the formation of surpluses of monetary availability, with respect to reduced private consumption. 5) There is a limit to the absorption of these surpluses through tributes, which is in relation to the economic and physical conditions of the components of the community and to the profitability of enterprises. This is a limit, therefore, that is not the same in all countries. 6) In so-called authoritarian States, the recourse to new taxes does not experience the constraint or the resistance of parliaments and the relative discussions that necessarily delay the adoption of drastic fiscal measures. 7) The moral sensitivity of governing classes and the ability to interpret the limit of tolerability of fiscal pressure as well as the reaction and the quiescence of taxpayers are objective and variable. 8) The limits to the recourse to loans are in relation to the credit that the State enjoys and with the stability of the purchasing power of money. 9) The proportions in which the increase in means of payment can be combined with capital (instrumental goods) and the work of those “unemployed” or not working before the war, and of the extraordinary expenditure without giving rise to inflation, are relative to individual national market situations. 10) The feeling of social solidarity and the willingness to collaborate are different in the various countries, in which political education applies to a different degree or where there is intimidation or suggestion of elements of the governing class. 11) The cost of public debt is dependent on the possibility of implementing a policy of money at good price and of control of private investments. 12) The different liquidity of markets influences the adoption of securities in the short or long term and the quality of the security determines the different successes of the issues through time and in different countries. 13) The stability of governments and of political systems is in a different relationship with the type of securities that can be issued and, indirectly, with the limits of

²⁸³ On p. 137 of the issue edited by FASIANI (in Volume V of the *Annali di statistica e di economia [Statistics and political economy annals]* of the University of Genoa) of the *Applicazione dell'algebra all'economia politica [Application of algebra to political economy]* (Introduction).

indebtedness. 14) The proportions of the increase in monetary income and of prices variably influence the formation of monetary surpluses that can be absorbed through voluntary loans or with tributary coercion when real income is reduced. 15) The different efficacy of rationing influences the sum of private assets and of corresponding monetary capital to be deducted from the satisfaction of current needs. 16) The delay in the implementation of restrictive norms and respectively the anticipation of rationing conditions the type of initial financing of war. 17) The limited elasticity of taxes (economic sensitivity) and its differing degree influences the limit and the temporal order of tributary exacerbation. 18) Bureaucratic efficiency allows fiscal innovation (new taxes) to a different degree, and the different degree of credit efficiency, in relation to the liquidity of the bank system and of the market, influences the release of taxes or the mobilisation of portions of national assets. 19) Enterprise self-financing, variable within limits according to the spatial-temporal examples, influences the forms of public payments; these can provoke private debt relationships towards bank institutions, based on the guarantee of securities or other treasury documents that are not classified as public debt. 20) The direct investments in industrial equipment on the part of States, carried out in part in time periods before the war and during the conflict, influence the policy of prices and of payments as well as that of financing forms that can be similar to those of private enterprises to a different extent in the various countries. 21) Hoarding, as a form of preserving purchasing power so withdrawn from the market, variably influences the limit applicable to the collection from loans and from taxes. 22) The writing off, to a different degree, of private assets correspondingly modifies ordinary and extraordinary taxation of incomes and assets. 23) The different state of conservation and of maintenance of public and private assets, on the eve of the time of extraordinary expenditure, influences the limits of its exceptional use²⁸⁴, as a substitution to the pro-rata recourse to loans and taxes. 24) The economic and psychological choice and effectiveness of fiscal procedures used to prevent private investment in wartime are determined by the formation of available funds directed towards public investments. 25) The orientation of the banking and insurance systems with or without State control towards the use of monetary available funds in public securities, variously influences “silent financing”, without direct relationships between the State and *individual* savers. 26) The limits within which it is possible to make recourse to foreign or mixed loans or systems (of the current American type) or to issue national currency on foreign markets, directly modify the proportions of the recourse to loans and to internal tributes. 27) The various forms of enticement of savers (premiums) or of persuasion (iron savings) or ultimately the temporary taxation with restitution at the end of the war of the sums coercively collected (English case), modify the limits to the recourse to loans and taxes. 28) The diverse composition of parliamentary majorities conditions the recourse to taxes respectively on consumption and on incomes, both those of progressive and regressive character, even if they appear to be suitable to the most rapid absorption of purchasing power surplus to private needs, limited by the authority. 29) The degree of equal distribution of tributes and of evaluation of taxable sums, on the eve of the event that provokes an extraordinary expense, influences the limits within which it is possible to make recourse to an increase in the applicable tax rates and the rapidity with which the choice can be made by governments without implementing additional reforms. 30) The variety of subjective judgments on the different psychological pressures (sacrifice of ophelimity) and the illusions that accompany them, with regard to the comparison from this point of view of an increase in the current tributary pressure (extraordinary tax) with the diffusion of the burden during an indefinite or long period (tributes for the servicing of loans or only paying for the interest), represent causal elements of the orientation of individuals, as taxpayers and as owners of capital assets of various natures, and of corresponding attitudes of the governing class.

The unsurpassable limitations of space led to the suspension, in my quoted and partly reproduced essay, of the list of factors determining concrete solutions, factors that “individually and in totality” and in various combinations, simultaneously or in temporal succession, confer *relativity* to the alternative (loans or taxes) considered within quantitative limits. The problem arises due to the marginal variations of the instrumentality of two fundamental institutions of war financing, which are normally used simultaneously in various degrees; however, the limit case of the use of a single

²⁸⁴ Wear and tear in plant and machinery and the depletion of stockpiles.

institution, to the exclusion of the other, is not only conceivable but it is even historically verified (in the example of the German war of 1870).

The preceding list, which has deliberately been extended and made rather comprehensive, cannot – nor does it intend to – be that which in a deductive approach to arguments represents “the complete list” that appears as the fourth rule of the Cartesian method. However, the thirty determining circumstances that I have listed and other imaginable ones, their combinations and their reciprocal internal influences want to lead to the understanding that it is extremely improbable that all of them would take place and would result in determining to the same degree, in different times and places, the solution to the *same* problem of the recourse to loans and taxes for the financing of an extraordinary expenditure.

The tendency of the human mind to generalise and, even more, the expression used in articulating considerations induced by the observation of events, of *given* events, can lead those who encounter in their study statements of the type of those referred to in letters *A)–N*) and *A')–D')*, listed above, to think they are in front of the so-called abstract universal uniformities, or uniformities valid without limits of time and of space, such as those based on the hypotheses that disregard the immediate relationships with the concrete phenomenon. These are hypotheses more appropriate to pure theory, devoid of historical-inductive links. However, it is often quite clear that this is a contradiction in terms due more to those who interpret the thinking of economists, which is not inherent in the so-called observation laws, conceived in this branch of social sciences with validity implicitly linked to the probability of the repeating over time and space of determining circumstances and their succession and approximately similar combinations (species and degree) or even, in this sense, identical.

III.

THE PROBLEM OF COMPARATIVE PRESSURE OF LOANS AND OF THE EXTRAORDINARY TAX IN PURE (DEDUCTIVE) THEORY

A) From the previous arguments derives, as a logical necessity, the methodological “anti-empiristic” or rationalistic orientation of those who set problems of economic theory, typically deductive ones. In their view experience induces the consideration of particular and determined problems from which scientific research takes inspiration, through the formulation of hypotheses. Those who believe that constructors of theories and formulators of static uniformities abstracted from experience in the selection of hypothetical premises are incorrect. What was expressed by Cartesio, who prepared for rational research by, as he actually reported, “gathering a good number of experiences to then make from them the matter of my arguments”, applies to all of them.

Those experts, from Ricardo to our time, who have deduced the effects of the alternative (loans or taxes), arguing hypothetically and reaching the known essentially statistical conclusions, worked in the same Aristotelian-Cartesian spirit.

From this derives a whole series of studies that, taking inspiration from Ricardo’s approach and with contributions by Loria, Pantaleoni, De Viti De Marco, Einaudi, Borgatta and Griziotti in particular, have “conditioned” the so-called problem of the *different tributary pressure of loans and of the extraordinary tax*, in the Italian literature.

There was a reference in the Ricardian model to an *identity* of pressure between loans and the extraordinary tax, considering the community as a *unit*, in other words, by keeping a single person in mind, as he used to do.

However, the great thinker did not limit himself to state the identity of the pressure of the two procedures, in an *objective* sense or with regard to the amount of wealth that, in both cases, passes from the private to the public sector. He also approached and resolved the *subjective* problem of incidence. Contrary to the opinion prevailing at his time (and to the ideas that other economists have supported later with limited success, such as Umpfembach, Messedaglia, Leroy Beaulieu, Ricca Salerno – this latter with limited conviction – and disregarding contemporary thinkers, in particular

the German ones), Ricardo suggested the thesis that the pressure of a tax and of a loan, in addition to being *equal*, in any case affects the *present generation*.

When considering this problem we refer to the vision of Pareto, who took the opportunity, when encouraged to express himself with regard to this, to articulate the usual polemical arguments against the “science of finance” as it was practised in his time, believing himself to be a “heretic” among those believers.

(I refer the reader to the vision that rigorously derives from the task that he assigns to pure and applied economy for the interpretation of the rational, objective and coherent thought that this illustrious thinker could not avoid conceiving. See the introductory part of this course of lessons, Chapter VIII.)

However, the objections he put against the argument put forward by Griziotti, who was soliciting his opinion on this type of problem, even though polemical, do not always appear to correspond to scientific methodology. Writing that “he had never come across any taxpayer who carried out Ricardo’s calculations, or similar ones” (in a letter to Griziotti in 1917, published by this latter in the 1943 edition of the “Rivista di dir. fin. e scienza delle finanze” [Financial law and science of finance review]), apart from the limited personal experience in the case in which the expression was taken literally, he could be considered to be against science. As has been seen, this is essentially hypothetical when it needs to comply with theoretical abstraction and not a description of events, as they are in fact found in reality. With regard to methodology, Pareto is a master.

In any case I had recalled (see: E. D’ALBERGO, *Sull’utilità di un “rapido” ammortamento del debito pubblico* [On the utility of a “rapid” amortization of public debt], “Giornale degli Economisti” [Economist Journal], April 1933) that the same Ricardo, having demonstrated the equivalence between payment of the capital value (extraordinary tax) and an annuity (presumed to be perpetual) for interest, concluded that “the public does not understand and in consequence does not regulate its own affairs” (on p. 539 of the *Essay on the Sinking-fund System*, published in *Works*, edited by McCulloch).

Ricardo was onto something when he differentiated between the rational behaviour presumed to be operating in *homo oeconomicus* and the unsophisticated behaviour of real subjects.

It is something else to recall the difficulty of the problem of the knowledge of *all* the variations of the economic equilibrium due to the interference of loans and taxes. Of course also in this case it is necessary to differentiate between simplified hypotheses and practical complex events, between overall variations of quantity as a function of the financial intervention and redistributions of them at the time and over time.

The same objection by Pareto regarding the effects of the use of revenues from loans or taxes was not welcome by Borgatta, who had derived from the Lausanne’s master his own visions, including sociological ones, of the financial problems, having observed that in the case of war, *at parity of destination*, it is necessary to set the problem of the mode of extraordinary collection.

Finally, the extra-economic variations that still determine the *real* problem (as has been seen in the previous pages) to which Pareto makes reference by recalling feelings, illusions, etc., of the people being governed and the particular interest of the governing classes, do not need to be taken into account: this is a matter for financial sociology, which I leave to those who have scientific faith in it or in political science, disciplines that I believe are appropriate in which to express empiric uniformities such as those seen in the preceding paragraph.

Having made this premise, let’s return to Ricardo who, from a methodological point of view, was dealing with pure theory when he approached the above mentioned problem.

His theory, from the point of view of the incidence of the burden on the *present* generation that had led him to a universal uniformity:

1) clashed against the “appearances” of the *technical procedure* by which, through the recourse to a loan and the payment of an annuity, presumed to be perpetual, for interest, it “would appear” that the next generation (or subsequent ones) also contributes to the payment of tributes with regard to the annuity for interest on the loan contracted by the current generation. Indeed, instead of the payment of an *actually high sum* (extraordinary tax), there are payments through a *long period of years*, which often includes more than one generation, of a *small* tribute corresponding to the service

of the payment of interest on the part of the State, on the *loan* contracted instead of the recourse to the extraordinary tax.

2) contradicts the historico-moral reasons, that would be represented by the justifications of the transfers in *pari passu* onto future generations.

In fact, the effort of the present generation (eg., for the defense of the national heritage from foreign invasion) produces a utility (economic, power politics, rise moral) that future generations will enjoy.

The argument by David Ricardo dislodged the prerequisite for the two orders of arguments. Ricardo had precisely stated²⁸⁵: “It would be difficult to persuade a man who owns 20,000 pounds or any other sum that a perpetual tax of 50 pounds is as burdensome as a single tax of 1,000 pounds. He would think that the 50 pounds will be paid by future generations, and, in fact, his heirs would have to bear that burden. However, I would then ask: what difference is there for them between receiving an inheritance of 20,000 pounds charged with an annual debt of 50 pounds and an inheritance of 19,000 pounds net of taxes? These comforting views regarding the future have become current arguments with very clever people, but we suggest that they appear to be inadmissible.”

Pantaleoni, who in a short and incisive essay – which however proves the indeterminacy of the term “generation” in describing collective production and distribution events, over time²⁸⁶ – claimed Ricardo’s solution and its illustration in Italy by Loria, and “grounded” the statement by the English master by adding a condition that may appear, as many other truths, obvious but that it is necessary to keep in mind. That is to say, for there to be *identity of pressure* between loan and tax and for the burden in any case to be carried by the current generation (from the moment the extraordinary expenditure is met), it is necessary that the respective *capital* is passed to the subsequent generation together with the burden of the annual payments (to allow the payment of the interest on the loan).

I will make the premise that, as will be seen, Ricardo’s vision, which considers the problem for the typical *individual*, presents more univocal developments. I refer to the relationship of “burdens” between “generations” in terms of information or of history of the theory, as the definitions of both the concept (“generation”) and of the relative production and distribution events over time are not univocal.

Returning to Ricardo’s example, for an heir it is indifferent whether they inherit 20,000 pounds charged with an annual burden of 50 pounds, or 19,000 pounds net of any burden; from this, however, it *does not always derive* that it is true that the heir, together with the annual sum of 50 pounds as perpetual debt, in any case *acknowledges* the *sum* of 1,000 pounds of *capital*, which is the capital that the sum is the relative interest of, as per the hypothesis.

This example relates to the frequent historical cases where the debts taken on by the fathers are paid by the sons, not with the assets that they have inherited – and which, if they existed, would of course be burdened by the amount of the debt as by a mortgage – but with the fruit of their labour.

“If the generation that contracted the debt had *assets greater* than the *contracted debt*, these assets will be passed to the following generation diminished of the capital value of the debt (even if it is only the burden of perpetual interest, and the payment of the interest, for the redemption of the burden it represents, at whatever time it happens, *cannot* represent a *burden* for the *subsequent generation*).

“However, if the generation that contracted the debt had *assets lower than the debt* taken out, or *no assets at all*, it would be a source of surprise that it has obtained the credit but there would be no doubt that the perpetual *interest*, which will burden *future generations*, will be paid *in part or in total* with the labour of *these same generations*, and that the redemption of the burden of perpetual interest, when it is implemented at a future time, would also consist in the delivery of a capital accumulated, in part or totally, by the new generations.”

I have expressed Pantaleoni’s view – which deserves to be developed in relation to the hypothesis of foreign loans, to which this argument applies in particular, and other specifications in part along the lines of those from Borgatta, which follow – because financial history has presented or

²⁸⁵ Essai sur le système des dettes cotasolidées, in “Oeuvres complètes” [All works]

²⁸⁶ Published in “Giornale degli Economisti” [Economist Journal], July 1891.

can present situations in which, at least in part and in a *marginal* manner, the situation might arise in the sense that the burden of a loan contracted by a generation is carried by the generations that follow.

Rather than a criticism, this comment by Pantaleoni is a complement of the theory formulated by Ricardo, who *implicitly*, perhaps, had in mind specifications similar to those of our own economist. However, other “specifications”, if not criticisms, have been put forward by other authors, especially Italian ones, when *examples* drawn from real events, keeping in mind the existence of proprietors and beneficiaries of income acting in the context of the same community, have replaced the hypothesis of *one person* or of the *community* as a *unit*.

The vision opposed to that of Ricardo, which Borgatta defined as that of the “practical ones” and characteristic of some academics, on the other hand suggests that: *a*) with the extraordinary tax, the burden of the extraordinary expenditure (for example, for war) affects only the generation that pays the same tax; *b*) with the public loan, part of the burden (or cost of war) is transferred onto incomes produced by later generations.

Solidarity between generations in terms of economic interest and continuity has been denied by Griziotti, for example, for whom, in the case of debt, the necessary taxes should be paid by the living only in their time until death.

Those who have differentiated (like Borgatta did) between the events of production and distribution, have observed that the payment of the relative interest on the part of the taxpayers of future generations represents simply a change in the distribution of the burden among elements of the community. For as long as the owner of the war loans is alive, he will receive interest and depreciation charges thanks to the taxes paid by other elements of the current generation. When the current generation has expired, the wealth of the following generation (which is represented by the wealth transmitted by the previous generation plus the *ex novo* one formed by the second generation), *does not diminish*²⁸⁷ because of the payment of interest and amortization of previous loans (for example, for war). “There is no renunciation of the enjoyment of new wealth in order to reduce the sacrifice of the war generation”, states Borgatta. “This is impossible and even unthinkable. The servicing of old loans simply implies the movement of the current wealth from some elements of the second generation to some others of the same generation. Therefore this gives rise to a *redistribution* of the overall income of the second generation among members of the same, not to a movement of wealth from one generation to another.”

The analogy that has been carried out between the events relative to individual (taxpayer-owner and his heirs) and collective (relationships between “generations”, a term not better specified) relationships is not always appropriate in clarifying the problem. This is even more so because, next to or in parallel with the relationship between the taxpayer and the owner's heir, there is a unique relationship between them and the state. As we are dealing with “generations”, the relationships are multiplied in a triangular way, as it is necessary to take account of the context of a generation including the relationships of distribution or transfer of incomes between creditors (for interest) and debtors for taxes. Furthermore, there is reference to “onerosity” of solutions, of “taxation”, of “cost”, of “sacrifice”, without adequate explanation of the sense in which the “generations” experience them.

In these arguments the stability of the purchasing power of money has been considered to be implicit, as in Ricardo's treatises. However, even when introducing an element of devaluation of this factor, it can be found that, always in the field of the distribution of burdens, those charged to the bond subscriber increase and those affecting the taxpayers required to service the interest and amortization are reduced.

Also in the relationship between generations, the overall wealth of the second generation is not reduced *for the time being* by events of distribution of purchasing power, among which are to be considered the owners of bonds (heirs of the first generation) and the taxpayers for the reduced burden that implies the payment of tributes *ti* pay interest on the bonds.

These arguments apply at the parity of the attitude of the owners of wealth, before and after the distribution events accentuated by the monetary factor (inflation and devaluation), for them to avail themselves of the capital for the production of new wealth, which *can vary*.

²⁸⁷ I would add “necessarily”.

However, this circumstance *may* be, as it often is, independent from the events of the redistribution implemented by the solution given to the financial problem: loan or extraordinary tax.

Furthermore, we have argued in terms of closed market, without considering interferences of imports and exports of capital from the country in which the problem is supposed to occur.

B) Leaving aside the perfidious, unstable and unclear ground of the relationships between “generations” or of the current taxpayers with their “posterity”, we now return to the problem of the identity of pressure between loans and extraordinary taxes, considering the problem in the context of the current generation.

I have reversed the normal order of the exposition because I will continue with the same problem, which Ricardo had set in objective terms or in terms of monetary quantities absorbed with the two procedures, treated in hedonistic terms. It is one of Borgatta’s visions that I have contrasted, as I will explain later, with my demonstrations of different solutions to the problem.

a) It has therefore been said that for “a man” who owns 20,000 pounds it is indifferent whether he pays the State 50 pounds in perpetuity (as a tax for the service of interest on a mortgage or a loan taken out by the public body) or 1,000 pounds only once, as an extraordinary tax, when we think in terms of a capitalisation rate of 5%.

It has been said that this Ricardian position is valid either for the community considered overall or for an economic subject (“a man”) who owns the sum in its monetary or liquid form and who considers this financial problem. If the subject is prepared to invest his capital at the same interest rate offered by the State, the adoption of the extraordinary tax or of a loan to meet the exceptional or non-normal public expenditure is *indifferent* to him. This comparison of solutions referred to as the pure capitalist who has available usable monetary means has been considered to be *implicit* in Ricardo’s argument.

If subjects can obtain greater returns (dividends or interest) from their available capital, because it is monetarily available, they will prefer the State to obtain a loan from someone else. In the case in which they achieve lower returns, they will prefer the recourse to the extraordinary tax.

b) The same variable (interest rate) influences the choice (presuming it to be possible) between the loan and the tax with regard to *proprietors* of moveable or immovable wealth. If in the *loan* relationship between private individuals (to pay the extraordinary tax) the *average* interest rate is lower in the market, the *extraordinary tax* is preferred. However, it is to be considered that in a great number of historical cases the State is able to obtain funds (loan) at an interest rate lower than the average one that would be available to private individuals in the sense recalled above (genesis of public debt in the De Viti sense).

c) For the *worker*, who does not have any capital, there is a dual reason to prefer the loan: 1) without any real guarantees, he is certain to have to pay an average interest rate, if he had to make recourse to a loan to pay an extraordinary tax, higher than that at which the State is able to obtain the loan of capital; 2) it is in his interest that he is obliged to pay the tax necessary to service the interest of public debt because (Griziotti) his fiscal debt is limited, in time, to the length of his life (even better, if it is linked to his condition of worker and receiver of an income).

d) Considering the relationship between loan and tax in a “dynamic economy”, Cabiati (*Il finanziamento di una grande guerra [Financing of a great war]*, Einaudi Editor, 1941, pp. 160-162), after having verified the identity of pressure in light of the *immediate* effects of systems (loan or tax), examines the *indirect* effects.

With regard to these he suggests the hypothesis, among other things, on the “mode” in which the State *will distribute* the subsequent tax, necessary to pay the private individual (from whom he has borrowed the sum to pay for extraordinary expenditure) in terms of *interest*.

If out of 5,000 units of interest, for example, the tax that this interest is paid with affects the saver-lender in the sum of only 1,000 units and affects other taxpayers in the sum of 4,000 units, he will *prefer* the loan to the extraordinary tax.

Elsewhere (p. 165) Cabiati continues: “The tax that takes 100,000 units away from the individual affects him immediately. The loan he underwrites for the same amount represents on the other hand a real *evasion* of the burdens of war at that very instant, because the individual had already intended to find a use for those savings. If therefore the loan brings less disturbance to the private

economy, on the other hand it creates dangers from the point of view of *distribution*. Let's presume that the State, having an immediate need for 200 million, obtains half of this amount through a voluntary loan and the other half through a tax. The effect of the system on the distribution of wealth will be different depending on the nature of the tribute and of other circumstances. If the tribute affected those classes that have not contributed to the loan, this would immediately mean a different type of treatment for two categories of citizens, favourable towards those underwriting the loan and unfavourable towards the others."

The student can find further considerations by consulting the quoted authors.

C) To follow Ricardo and those who have expanded his vision, rather than criticised it, with a range of examples that diverge from the simplest case of indifference in the adoption of different and contrasting procedures, we have remained in the context of an atomistic vision, in the sense in which we have discussed it in other parts of these lessons.

However, the problem of the extraordinary expenditure, in particular in the hypothesis of military defence in the case of war, is characterised by "mass" dimensions. It is not possible to solve a problem such as that of the collection of a relevant portion of the assets of a country without making recourse to new means of payment that allow us to translate capital or equivalent assets into money. And what many authors have written complicates the problem that until now we have considered from the point of view of individuals or typical subjects.

The phenomenon of inflation and of monetary devaluation, with the complicated and additional burdens and benefits that it brings, is added to the financial phenomenon as a fact of redistribution of wealth. This is the reason for which the programmatic approach of the financing of war without incurring inflation was conceived.

This will be discussed in the vision of the mass and non-atomistic problem, in the paragraph on the "circuit of capital", as a procedure tending, in theory, to eliminate the pathological fact of monetary inflation.

D) For now, remaining in the field of atomistic visions, I will pause on a fundamental aspect under which the problem of the alternative between loan and tax has been presented, and about which I wrote in the dedicated essay I have already made reference to in this chapter²⁸⁸.

It is a matter of introducing the *time* factor in arguments in which not only objective quantities (monetary incomes, taxes, interest, etc.) but above all *hedonistic* quantities (opphelimity or subjective utility) are considered.

Limiting myself to taking into consideration the *point of view of the individual*, I intend to contribute to the formulation of some hypotheses, different from those taken into account by Borgatta in his original contribution in which he in fact approached the Ricardian-type problem considered here on a hedonistic basis, that is to say, he considered the "pressure" of the loan and of the tax in terms of subjective "sacrifice of utility". We have seen that in the past the problem of the different or identical pressures of the loan or tax were perceptively approached, with subtle analyses due also to some of our illustrious academics expressing the concept (pressure) in terms of capital or income, respectively collected by making recourse to one-off taxes or to loans for the solution to a problem of extraordinary finance.

In his interesting investigation Borgatta demonstrates the convenience for the individual of the system of loans (preferable to the extraordinary tax) because this solution gives rise to a lesser sacrifice of utility. Briefly, the author demonstrates the inequality between (*A*) the utility destroyed by the extraordinary tax (presumed to be on income) and (*B*) the actual value of the perpetual annual amount of utility destroyed by the perpetual tax collected annually for the payment of the interest to those (different from the individual considered) who have underwritten the loan. In the context of the hypotheses considered $A > B$.

(It is first of all presumed that the State, in adopting the system of loans and in leaving to individuals the formal availability of the income net of normal pre-war taxes, allows them to satisfy

²⁸⁸ E. D'ALBERGO: *Prestiti e Imposte nelle nuove teorie e nella esperienza bellica [Loans and levies in new theories and in the war experience]* ("Studi dell'Istituto di scienze economiche e statistiche" [Studies of the Institute of economic and statistical sciences] of Milan University, 1945).

needs that they used to satisfy in the past without the need to restrict consumption as well as avoiding the need to impose blocks or bans on incomes that are distributable or available for expenditure, or obstacles to investments of the income saved.)

Presuming that the taxes necessary for the payment of the interest on loans are charged to individual incomes in the *same proportion* as the extraordinary tax, to consider a model that I will develop over the next few pages, I will compare the hedonistic calculations of *a single individual* who considers the issue over time. In this way I will disregard the unnecessary hypothesis (and according to the same Borgatta, of secondary importance) that the income utility curve is the same for all taxpayers, as physical persons.

To briefly recall the argument of the author, I will keep in mind, again for the single individual, the diagram on which the sums of income are represented on the x-axis and the marginal utility of income is represented on the y-axis.



Figura 73.

Let Rm be the income that the actual extraordinary tax takes away from the subject, whose minimum income, declared as not taxable by sociological premises, results in being equal to OM . Let the area mRN measure the utility destroyed by the tributary collection (in the hypothesis of the “hail tax”), because of the renunciation on the part of the subject of the satisfaction of private needs, determined by this taxation.

If the State conformed to the other alternative of the issue of a loan presumed to be perpetual and not underwritten by the hypothesised subject, a perpetual direct tax would have to be charged to him on the income that is presumed to be derived from a similarly lasting source, for the purpose of allowing the State the means to correspond the interest to the other subject who had loaned it a sum equal to the extraordinary sum not collected. Imagining that the subject calculates the current value of the perpetual sum of utility $RNnr$ corresponding to the series of payments necessary for the mentioned corresponding payment of interest represented, pro-rata, by rR , Borgatta wrote the following inequality:

$$\frac{RrnN \cdot 100}{5} < MrnS$$

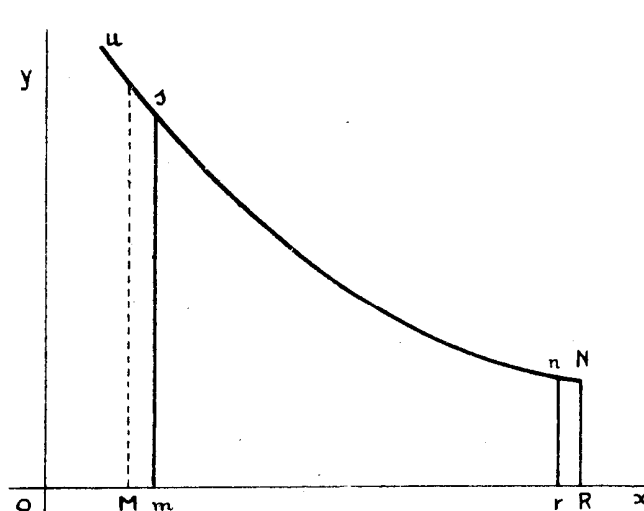
From this argument the convenience, from the point of view of the subject taken into consideration, of the solution to the problem of the financing of an extraordinary expenditure by making recourse to a loan rather than a tax is undoubted.

Among the premises that I believe to be logical in considering implicit in the argument that leads to such a significant general conclusion, it is necessary in my view to consider the following ones, on the variation of which it is possible to obtain a contrasting and in any case a different

solution from that found by the author in the approach to the problem of the alternative between loan and tax:

α) The revenue, in money, is maintained at an unchanged level (during the period of time considered for the comparative calculation above) for the subject and for the community.

β) During the period of time considered for this argument, the subject remains unchanged with regard to his physical and psychological characteristics. That is to say, “the man is at the start as he is at the end of the period” (according to Marshall’s expression); in other words the individual “remains the same as himself”, to use Pareto’s terms, when he was considering comparisons between ophelimities over time, *alias* between the current feelings and the feelings caused by a distant event. Ultimately, in brief, it can be said with U. Ricci that the “constancy” of the individual or subject is presumed, from this point of view.

γ) As a consequence deriving from this hypothesis, it is presumed that the subject does not anticipate: 1) the arising of new needs in the future, in himself or in persons already existing or in “new” persons “connected” to him; 2) the intensification of pre-existing needs.

δ) There is no intervention of the subjective rate of discount of pleasures or utility, and if this has already caused its effect (on the curve of the current utility of future income), this is maintained constant over time.

ϵ) The general level of prices (in the sense of all prices) remains stable. This hypothesis is formulated because I consider the hedonistic calculations of *one* subject, whose individual monetary income can vary, independently of the trend of prices in the market.

If we let variations *in a certain sense* of the hypothetical presumptions suggested here as most likely implicit in the approach to the problem on the part of Borgatta, we will reach a solution that may be different from the general and the most important one found by the author.

I) Let’s presume the “constancy” of the subject from the physical and psychological point of view and from the point of view of his needs or the needs represented by him, and let’s consider the intervention of hypothetical circumstances, at parity of psychological rate of discount, represented by the prediction of a decrease in future income. (The hypothesis is not anti-historic and can be found among the ones admitted by the author – on p. 217 of the quoted work – in the discussion of the effects of the tax on capital, when Borgatta wrote that the events of future incomes are ignored and that there are reasons to fear reductions because of the probable fall of prices in the post-war period. In this case the probable variation of *collective* monetary income is taken into account while, for the moment, I will consider the variation in income *only* of the single individual, in the sense of a decrease.)

This forecast by the subject can be presumed to refer to the moment in which the problem of the alternative between loan and tax is raised (t_0) or at the end of the first period of time (t_1) after which the hypothesised decrease in income takes place.

Let’s make the hypothesis of proportional, extraordinary taxation, which is “more frequent”, according to Borgatta, in the financing of war.

Let the decrease in future income be forecast also by calculating as available income the portion of possible income from *savings* that the subject is able to make because of the non-collection of the extraordinary tax, when the State makes recourse to the issue of a loan.

Let’s presume that the subject has at his disposal an *unlimited* “economic period”; in other words, “let’s think of a period of time indefinite but long enough to be considered equal to eternity” for the distribution of wealth over time²⁸⁹.

Having made these premises, if in addition to the presumption in particular of the “constancy” of the subject, of his own needs and those of persons “connected” to him and of the non-variation of the psychological rate of discount, the hypothesis of future prices equal to current prices is formulated, it can be presumed without any arbitrariness that the current curve of utility (of current

²⁸⁹ This hypothetical pretence was taken into account by Fasiani in examining some of the presumptions of the discrimination of tax rates and taxable incomes, in *Annali di statistica e di economia [Statistics and political economy annals]* (Genoa 1936).

$$\int_m^R f(x)dx \begin{matrix} < \\ > \end{matrix} \int_r^R f(x)dx + z \int_i^V f(x)dx \dots [1]$$

The coefficient that multiplies the integral, in the preceding expression, is $z < k$, because k would have been, in Borgatta's example, the constant (100/5) by which the area $RNrm$ would be multiplied, disregarding the variation of the income of the subject over time. Instead, presuming that the collection of the tax on income takes place against the lower taxable income MV indefinitely, starting from the second period t_2 , the perpetual taxation in effect is *deferred by a period*. It is added to the taxation of the first period t_1 , until the end of which the taxable income is unchanged at quantity MR , from which rR was collected, according to the hypothesis.

Arbitrarily the case of a contraction of taxable income starting from the end of the first period, equal to 50% of MR , or equal to MV , is shown in Figure 74. Having admitted this, also using the "trapezoidal rule" for the measurement of the areas represented above and disregarding the defect error (due to the trend of the curve with convexity toward the positive γ -axis), it is possible to geometrically deduce the inequality, in the sense that the amount of utility sacrificed by the recourse to the loan is *greater* than the sum of utilities that the extraordinary proportional tax on taxable income MR would have destroyed, in the opposite case. The aforementioned solution also depends on the *shape* of the income utility curve traced on the diagram.

If we wanted to generalise, it must be said that the solution to the problem depends on the way the marginal utility of income decreases when it varies or, in brief, on the *elasticity* in the subsequent sectors of the marginal utility curve and on the proportions of the hypothesised contraction forecast in the future taxable income.

II) According to the hypothesis suggested at point a alongside what has been taken into account so far, we make the case in which the subject considered forecasts not only of the reduction of *his* own future monetary income but also the contraction of the monetary income of the *entire* community. Having said this, let's presume that the State needs (*all other things being equal*) to meet a fixed burden with regard to interest, having *excluded* the hypothesis of a conversion of the income (for example 5%) in the sense of a reduction. In this case the State will have to distribute, *pro-rata*, the constant burden of the service of the interest on the loan, increasing the collection of taxes on individual incomes, so as to obtain the necessary revenue to meet the fixed, overall expenditure for the payment of the same interest.

Because, in the given example, taxation will have to go over the 5% hypothesised so far, against the income of the subject, the tax will be $tV > iV$ and, generally speaking, it will be represented by a segment greater than iV . It is therefore conceivable that, in the symbolic expression indicated above, the following sign of inequality will figure with greater probability:

$$\int_m^R f(x)dx < \int_r^R f(x)dx + z \int_i^V f(x)dx \dots [2]$$

That is to say, it is more probable that, *all other things being equal*, the *convenience* from his point of view of the *recourse to the extraordinary tax* (rather than the loan) for the financing of the exceptional or war public expenditure, in the most frequent case, is taken into account in the hedonistic calculations of the subject.

In the Figure, the expansion of the area from $iVV'i'$ to $tVV't'$, induces *a fortiori*, with respect to the arguments at the preceding point I), the realisation of the solution that it is presumed the same subject can opt for. However, also in this example, changing the percentage of reduction of future income and the rate of decrease of the marginal utility of monetary income, in other words, the elasticity of the relative curve, it is possible to return to the case of the indifference of the subject with regard to the compared solutions or to the preferability of the loan over the tax. In other words, it is possible to return to the symbolic expression generalised above [1].

III) I will now introduce the hypothesis opposed to that of the “constancy” of the subject presumed so far, and I will admit not a modification of *shape* (which is quite probable also in the real examples) but to a variation of the *height* of the curve of marginal utility of monetary income. This is so because of the desire for simplicity in the demonstrations that follow.

That is to say, the subject anticipates starting from the end of the first period of time, at parity of future income: 1) the arising of new needs for himself; 2) the arising of people “connected” to the subject, for which he interprets ophelimities and makes choices; 3) the intensification of pre-existing needs at time t_1 . Let’s presume that this complex forecast, from the start of the second period t_2 for an indefinite time, has the effect of increasing in a parallel mode to itself the future utility of the future income curve, at parity of amount.

In Fig. 74 the curve extends to a height of uN' . From this derives the increase of the marginal utility of taxable income MR , such as the taxation at $N'R > NR$; in consequence the utility destroyed by the tax of $5\% = rR$ for the service of the perpetual loan becomes, starting from the end of period t_1 (for which the “constancy” of the subject had been presumed), $RN'n'r > NRnr$. Instead of the inequality expressed by Borgatta, in terms of the hypothesis that applies here, it is possible *generally* to have the limit case of *indifference* of the subject for the loan or the tax, or even an *inequality* that expresses, as is very likely, *the preferability of the extraordinary tax to the loan*, as it is expressed below, also to take into account the evidence of the *specific* case of extent uN' , shaded in Fig. 74:

$$\int_m^R f(x)dx < \int_r^R f(x)dx + z \int_r^R f_1(x)dx \text{ --- [3]}$$

where $f_1 = \alpha f(x)$, being $\alpha > 1$.

The extent of α or the consequent distance of the new future utility of the future income curve, which is uN' in the diagram, from UN , hypothesised until the end of the first period, will be a factor determining the solution to the problem, if the other circumstances already mentioned remain the same, including the elasticity of the marginal utility curve, from the point of view of the individual who, if he is a typical subject, can take account of the governing class in his calculation of convenience for the community.

IV) I will now consider the intervention of the factor until now imagined to be neither influential nor unchanged: that is to say, the psychological rate or subjective utility or future pleasures *discount*.

Let the subject be typical of a category of rather provident people, for whom this rate is relatively low. To ensure that the hypothesis corresponds to the graphical representation (Fig. 74), let’s admit a rate of 10%, such that it influences the hedonistic calculations of the same subject for whom the “future” starts from the second period t_2 . Also in this case (with a pretence similar to that relating to the variations of future income) let’s presume that the discount rate adopted by interpreting the attitude of the subject remains indefinitely constant.

Let’s return to the initial hypothesis of a *contraction* of the future taxable income (anticipated starting from the second period), from quantity MR to quantity MV , to which the subjective discount rate indicated above is applied from a hedonistic point of view. Let’s therefore presume that the section of curve UN corresponding to the income MV , under the influence of the psychological discount rate of 10%, results in the transformation of the (shaded) U' , and represents the marginal and *present* utility of future income, forecasted to be OV .

The marginal utility of income MV will be $pV < VV'$ before the collection, and $p'i < i'i$ after the collection of the same tax (5%) which is charged to the subject both at time t_1 , when the income is OR , and at the start of the second period t_2 when the monetary income is anticipated to be indefinitely reduced to OV .

Having made these premises, and taking account of the elasticity of the marginal utility curve and of the proportions of the contraction of future income, we can deduce: 1) the confirmation of the inequality suggested by Borgatta; 2) the limit case of the indifference of the subject for the two

financial alternatives contrasted here; 3) the inequality contrary to that expressed by the illustrious author, from which derives the convenience for the subject of the recourse to loans rather than the extraordinary tax.

The argument can be repeated, making the hypothesis of case II), of a contraction in the income of the entire community and of the increase of the collection of the tax (above the 5% level) to meet a global fixed burden for the interest on the perpetual loan to the State. In Figure 74 the increase in the tax from iV to tV has been hypothesised.

After the preceding points, it is possible still to write, logically:

$$\int_m^R f(x)dx \underset{>}{\leq} \int_r^R f(x)dx + z \int_t^V f_1(x)dx \dots [4]$$

Where $f_1 = \lambda f(x)$, this being the coefficient of proportionality $\lambda < 1$. At parity of other circumstances, the *variation* in time of the psychological rate of future utility discount modifies the solution to the problem considered by the same subject. Generally speaking, the trend towards the increase in the same rate makes Borgatta's inequality more probable, *all other things being equal*.

Generalising again, at parity of psychological discount rate, it is *probable* that the contrary inequality (that is to say, that the subject prefers the extraordinary tax to the loan) or the limit case of the indifference for the solution to the problem are realised, in function of the anticipation and of the proportions of the increase in future taxation, in the hypothesis that the overall burden for the loan remains nominally constant in terms of interest rate and that the forecast monetary income of the community decreases in future.

V) Lastly, I consider the case in which, even though the current and future income of the individual are the same in monetary terms (even more so in the case in which this equality has not been anticipated and future monetary income decreases) the future prices of goods and services that our subject must pay for in the market display an increasing trend. This could be the case of a prospective devaluation of money, in periods of time subsequent to the first one, when the problem we are considering has been set. It would be possible to deduce a proportional increase of all prices, on a purely abstract basis.

In a first approximation it is possible to believe that the increased future prices are "an indirect mode of decreasing future income", as for example Ricci had presumed in setting a rather similar problem to the one considered here (that is to say, in the determination of the amount of savings of the rational individual). If it is admitted that, in the judgment of our typical subject, the forecast of a proportional increase in prices of goods and services appears to be equivalent to a contraction of future income (starting from period t_2), we return to hypothesis I), which was examined at the start of the series of examples above.

VI) The inequality exposed in Borgatta's general presentation, reasoning on the basis of the factor of "utility" sacrificed by the subject (in relation to contrasting procedures for the financing of an extraordinary expense in the sense that would make the loan preferable to the tax) is very likely to be valid, making the opposite hypotheses to those expressed in cases I, II, III, IV and V above or maintaining the *all other things being equal* status, implicit in the author's argument.

Similarly, from a logical and a historico-statistical point of view, circumstances such as the ones below reinforce his conclusion from a first approximation: *a*) the uncertainty of the enjoyment of the utility of future income for reasons relating to the subject, pertinent to the duration of life, physical conditions, etc.; *b*) the fact that the subject has an "economic period" that is *limited and of "uncertain" duration* or limited to a determined number of periods of time among which, once he has drawn his budget plan, to distribute income or enjoyable wealth; *c*) the extension of the uncertainty of the source of monetary income (objective risk), etc. With the arguments in points *a-c* and with conceivable similar others, some of the factors already examined or similar to those that will be taken into account by academics, especially Italian ones, to complicate, with a subtle set of cases, the Ricardian expression of the identity of pressure (in an objective sense or in terms of monetary sums

collected) between loan and tax are recalled for *repercussions on hedonistic quantities* (ophelimity, subjective utility).

E) In closing this section of this short essay, I presume that the hedonistic calculations (on the basis of subjective utility) that are added to the objective ones (about monetary quantities) are not based on *illusions*. Those were in part those that, with the bitter pessimism for which history unfortunately suggests that there are grounds, were recalled by Pareto²⁹⁰ with regard to the substantial disappointment of those who trust the State with their savings by underwriting loans and then end up losing a significant part of the capital lent, mainly due to the occurrence of monetary devaluation. In any event, in the hypothetical cases that I have considered above in the development of Borgatta's approach, it has been presumed that the subject does not personally underwrite the loan bonds whose emission he prefers to the possibility of the collection of an extraordinary tax.

Similarly it is excluded that the hypothesised subject, whose rational arguments have been interpreted, is the victim of the illusion that affects the "normal taxpayer" who (as Fasiani specifies in explaining and generalising Puviani's arguments) is not aware of the equivalence between paying a certain amount once in a while and paying in perpetuity its corresponding annual yield²⁹¹. I presume that in our case the subject is perfectly rational and able to anticipate, evaluate and compare hedonistic quantities (ophelimities, pleasures, needs, subjective utility, etc.) in *time* without the intervention of this factor determining cases of psychological colour blindness.

It is clear that the constraints – especially in hypotheses of controlled economy, such as apply to the choices of subjects as hedonists, in particular in certain historical phases (wars, etc.) where the problem of the financing of an extraordinary expenditure arises – limit or neutralise the influence of the subjective factor (utility) considered in the previous paragraph. Nevertheless the close examination of the hypothetical model that introduces considerations of utilitarian-marginalistic character does not lose its own logical value. The abstract and tendential uniformities that appear in these pages maintain their theoretical importance, indirectly shedding light on alternate solutions to the real problem of the instrumentality of the loan and of the tax for the purpose of meeting an extraordinary expense.

F) Incidentally, Borgatta, after my criticism and appreciating my investigation, referred readers to it in an article published in the "Rivista Bancaria" [Banking Review] (March–April 1946). He intended to insist on the solution by modifying the terms of the problem he had set, that is to say, to take refuge in Ricardo's model in which, as has been seen, the extraordinary tax on assets or capital is compared with the tax on income relative to the service of the public loan for the payment of interest.

With regard to this, Borgatta stated that the conclusions he had reached were valid within the limits of the Ricardian hypothesis, according to which, implicitly and explicitly, the extraordinary tax must be considered as being *proportional to capital* even though it is *payable with income*.

Furthermore, he pointed out that to determine the most convenient choice for the taxpayer it is necessary that the variations of utility, prices, income from capital ("which Ricardo presumes to be a fixed income"), etc., should be *anticipated* at the time of the same choice. Indeed, "if the taxpayer (and the market) anticipate an increase in the income from capital in subsequent years, the actual value of the capital would be higher, and vice versa. If they were to anticipate a variation of the subjective interest rates (and therefore the market rate, because there is no reason that the anticipation should be limited to the taxpayer) then the value of capital and the amount of the tax would also change. Therefore," he continued, "the hypotheses by d'Albergo apply to those cases in which the extraordinary tax is proportional to income and within the limits in which the variations in the examples are anticipated at the time of choice."

In a footnote I drew Borgatta's attention to the fact that the case he had hypothesised, contrary to what he had stated, regarded precisely the *extraordinary tax proportional to income*, distributed on all incomes (by pure capital, work and a combination of capital and work, according to his

²⁹⁰ In the recalled previously unpublished letters to Prof. B. Griziotti, in issue 3-4 of the *Rivista di diritto finanziario e scienza delle finanze* [Journal of financial law and the science of finance] (1943).

²⁹¹ *Principii di scienza delle finanze* [Principles of the science of finance] (Turin, Giappichelli, 1941) pp. 116-117 of Volume I.

specifications) exceeding the minimum for subsistence and the maintenance of the productive capital. In other words, Borgatta had not only already carried out a comparison between *funds* (assets, capital occasionally affected by the tax) and the *flow* (income) that is affected by the collection of the tax to be destined for the payment of interest on the loan, as was the case in the Ricardian model, but had also made a comparison between *flow* and *flow*, as taxable income in the alternative to the extraordinary tax and of loan, as modes to resolve the problem of the financing of an extraordinary expenditure. Coherently with the assumption of my quoted essay, which was precisely to demonstrate the partiality of the conclusions expressed by Borgatta (reaching opposite or indifferent solutions, as was seen), in the same essay I conformed to the hypotheses from which Borgatta had started and that made me consider the “Ricardian-*type*” problem.

The conclusions – as those who have analysed Borgatta’s scientific work from a professional point of view must have argued – cannot be different from those I suggested in the quoted essay from which the demonstration above is an extract.

IV.

EXTRAORDINARY TAX ON PROFITS FROM SPECIAL ECONOMIC SITUATIONS

Extraordinary tax on profits from special economic situations (for war expenses, in the most frequent case).

An *extraordinary* tax whose logical and historic legitimacy *is not* be disputed from the *point of view of the loan alternative*, is that which regards the taxation of *profits* deriving from the same *economic situation* which gives rise to the extraordinary expenditure. These generally arise from financial policy acts of extraordinary character (modification of the monetary regime, of the customs regime, autarchic approach, concessions of monopolies to enterprises in production, export, shipping, etc.)²⁹².

The circumstance that, as was explained in presenting the concept of “relative contributive capacity”, leads most countries to find a logic in the introduction of an extraordinary tax on profits that are determined by public expenditure and all economic and social policies, is that of *war*. The event that compels the State to make an *exceptional demand*, in terms of amount because of the urgency required by war instrumental assets, is represented by the imposition of the extraordinary expenditure needed to meet the needs of military defence and action generally. There is a complex category of entrepreneurs and subjects, normally represented by industrialists, traders, intermediaries, agricultural entrepreneurs (tenants) who are presumed, essentially, to enjoy a *differential* advantage from the war event, because of the supplies that the State requires of the category of economic subjects identified here, and because of the increase in prices that takes place also because of the demand on the part of private individuals.

From the economic-rational point of view, it is admitted that the war represents the circumstance that, almost regardless of the “merit” or of the ability of entrepreneurs (in the sense in which Pareto considers *speculators* in sociology, as subjects particularly adept at deriving benefit from economic situations and combinations), determines in itself the *possibility* of *earnings* higher than those that *normal* times allow producers in the wider sense. There is, indeed, a particular and differential use of circumstances put in place by the same State for the satisfaction of some pressing needs, in certain phases of history. The extraordinary public expenditure, in light of the theory that I have referred to, in the dedicated chapter, of the “relative” contributive capacity (Stamp defines this as “special”), and other constraints (limitation of foreign competition due to closure of the market, presumed to be isolated at least from enemy countries), lead to the opportunity for *differential earnings*, both with respect to the historically and conventionally normal periods, and with respect to incomes achieved by those who do not benefit (or on the contrary they are damaged by) the extraordinary event which here, in the most significant example is represented by war.

²⁹² These events also justify extraordinary levies on assets or capital.

It will be remembered that the theory that identifies “relative or special” contributive capacity does not justify only the differential *progressive* imposition but also the *proportional* tax, in addition or complementary in relation to the limitation of the concept of a particular capacity to bear tributary burdens. In the case in which the circumstance to be taken advantage of is war, the *economic* character of the differential utility or profit is so apparent that the progressivity of taxation seems more apt to correspond to the differential benefits that war brings (even more so when there is contrast with the damage that other categories suffer from the same event).

This latter argument, in brackets, brings us closer to the social or political aspect of the extraordinary taxation of war profits. Indeed, from the point of view of mass “feelings”, it would appear that a certain “justice” in the distribution of burdens and benefits requires those who have benefited from the war to at least contribute to the expenditure of war and in particular to the post-war financial reconstruction. The argument, as I was saying, is compelling because of the contrast with the missing profits and accruing damages affecting other categories, sacrificed by the economic situation. Someone wrote that it would “impolitic” as well as “unjust” not to tax profits deriving from war in a differential manner.

The shifting at work of the concept of extraordinary taxation of incomes deriving from a specific economic situation is not as easy as the expression of the idea in the field of logic and in that of financial policy or social morality.

Indeed, it is a matter of *separating*, not only ideologically but also from an accounting point of view, “normal” income from *surplus income* or the income or profit from the specific economic situation. The terms of the relationship are represented: *a*) by the income achieved in the base period (for example in one year in the immediate post-war period) or in the medium term, achieved over several years; *b*) by the capital invested in that period. The part *exceeding* the percentage, presumed to be standard, for example determined to be a minimum of 8%, would represent an income above the norm or a greater profit or surplus war profit. Having defined in this way the concept of income from a specific economic situation [rather than as the difference between the absolute amount obtained before (*r*) and during the war (*R*)], to be subjected to extraordinary tax, it is clear – as has been observed by Barone in particular – that, indicating normal income with *r* and income during the period of differential economy with *R*, the *higher income* in absolute terms, represented by *R - r* is not the amount taxed, but rather the *percentage of excess* of income with respect to the capital, compared with the percentage of the base or “normal” period.

In other words, the following percentage becomes the object of the extraordinary and *progressive* tax:

$$\frac{R - r}{C}$$

where *R*, as has been seen, represents the income in wartime, *r* the income during normal times and *C* the capital invested in the enterprise (which can decrease or increase after the base period).

Barone criticised this system because it leads to progressive taxation and therefore to taxing to a greater extent the enterprises that have obtained *R* with a *lower capital*; in other words, the enterprises that are able to achieve a greater profit from a given capital because of their superior organisation are taxed relatively more than enterprises that are less efficient, given that the tax becomes progressive with the rising of surplus percentages.

Barone’s arguments²⁹³ are accentuated if we contemplate that, for example in the Italian legislation (of 1940), the *social capital* underwritten and paid, with the addition of the ordinary and extraordinary *reserves* in each year, resulting from the balance sheet (after deduction of losses), is considered to be the *invested capital* in the enterprises organised as anonymous societies (the *C* in the formula). There is no indication in the statistics that there is a uniform correlation between financial size (amount of social capital) resulting from official *documents* and *actually invested* capital;

²⁹³ See *Principii di economia finanziaria [Principles of financial economy]*, Appendix II.

furthermore, the uniformity of the relationship between the size of *social* capital and the rate of corresponding profits has not been proven. (Let's consider the case in Italy, whereby from 1936 to 1939, with the encouragement of the legislator, there were increases of relevant capital for some enterprises, and negligible or no increases in others which, did not think necessary to increase the social share capital because of subjective directives due to company policy).

In any case, Barone suggested that the "profit" element should be broken down into the *interest* on the capital (which should be taken away from R and from r) relating respectively to C and c (capital in the war period and in the normal period) and what is presumed to be the *profit* of the enterprise, to be verified in a differential way. The procedure does not seem to be easy to implement even though it is rational, given the difficulty of ascertaining what should be considered to be the current *rate* of interest, for the various types of *enterprises*. These are *heterogeneous* with respect to the "risk", the start-up, etc., and also in numerous and economically differentiated *local markets*, into which the national market is divided.

I think there is a more rational (and also more practical) way of making these relationships more *homogeneous* and to take into account with a degree of approximation, albeit *indirectly*, the real event of the relative importance of the factor represented by the capital "*actually*" invested in the enterprises, which is an entity to which normal and extraordinary income can be referred; furthermore, the variations of capital employed in the war period is *implicitly* taken into account. Moreover, account is taken of the capital of others, of supplementary credit, of additional work and, generally, of all the objective and subjective factors (variations in the composition of the direction as "mind" and ability of the entrepreneur, over time).

I refer to the *relationship* between "net" profit or normal *income* and *intake* or "gross" profit in the *normal* period compared with the relationship between income or net profit of the *war* period compared to the gross intake in that period. That is to say, a percentage or a general portion *corresponding* to the relationship between net income and profit and gross intake of the normal period should be deducted from the gross war intake. The difference "should" be considered attributable (as a greater gain or greater rate of profit) to the effects of the "war" economy, and as differential income subject to specific, special and in any case extraordinary imposition. The (extraordinary) concept is normally interpreted in the temporal sense, in addition to the sense of the increase of the burden, that is to say, in relation to the *duration* of the favourable *event* for entrepreneurs and, generally speaking, the passive subjects of this tribute.

Criticisms of the type that Barone put forward against the criterion presented above cannot be advanced against this mode of representing and ascertaining the income or profit surplus as normal.

Furthermore there is *homogeneity* of comparison terms which may be missing when the *absolute* amount of net income achieved due to the war situation and income, also in *absolute* terms, for the normal period are used as quantities to be compared. It is not a criterion without critics (see Borgatta, *op. cit.*).

However, neither does this author agree with my argument. In my view the normal and exceptional circumstances that, in the complexity of their combinations, can influence the income of enterprises are identified in a *relative* manner in the criteria highlighted in these pages. In essence, profits at parity of coefficients of productivity are compared over time, complying with the specific conditions that influence the ability of individual enterprises to achieve profits from the complex activity in which internal and external circumstances concur: a constant coefficient appropriate to the verification of differential profits also due to causes extraneous to the merit of entrepreneurs, such as is the case in a war economy in particular.

This relativity of economic positions might not be highlighted by the comparison between absolute levels of income or profit in two different times. If someone can achieve a profit or an income of 500 million from a turnover of 5 billion, when he did achieve a profit or an income of 100 million from a turnover of 1 billion, he could not be said to have achieved a higher or surplus income, as it would appear from the comparison of the absolute values of the difference between 500 and 100 million. For the 400 million difference he will pay the *normal* tax rate. The *extraordinary* tax we have talked about will be paid in relation to all amounts exceeding this. (It is superfluous to warn that the numerical example is presented in a very first approximation, that is to say, in the sense that the

constant proportionality of turnover and profits, such as can be inferred from the simplified figures, is admissible.)

Aside from generic presumptions, the *actual* divergence between what normal circumstances and what war circumstances are allowed to achieve is compared with the *real capacity* of each enterprise to behave as a “speculator”, in Pareto’s sense, in the period favourable to the achievement of exceptional profits. The relative position of each enterprise would be identified, without inequality, from the relationship between turnover and net income, in the two periods, which in turn identifies the profit rate.

In any case the manner of ascertaining taxable income as presented above allows us to integrally obviate the inconvenience represented by the different extent to which *capital* (as defined in the legislation, that is to say, social capital with the addition of reserves and subtraction of losses) diverges in a juridical sense from the capital actually invested in production processes.

All enterprises would be taken into consideration on the basis of economic elements or because of their actual and respective “dimensions” (with the exclusion of those that are not homogeneous, formal and juridical, which in particular dominate collective enterprises). These would be elements between which there exist certain relationships that, in the case of individual enterprises or categories of enterprises, present some objective and significant uniformity.

To give a flexible and *tendential* idea of the mode in which the concept of differential income or war profit should become apparent from facts, I explain it in the graphical representation in Fig. 75.

Let’s represent the quantities produced on the x-axis and prices on the y-axis. Let’s advance the hypothesis of the condition of free non-“ideal” competition, such that the enterprises whose behaviour is examined, in relation to the variations of the specific economic facts, is not at the vanishing point (*F*), where there is equality of price, average unit cost and marginal cost (coinciding with *FR* in the Figure). Let instead the equilibrium position of the enterprise hypothesised here be that determined at point *S* by the equality to the marginal cost of the price, which, in the case of an individual enterprise, as has been said before (Chapter X, paragraph II), is a factor that can be graphically represented with a parallel to the x-axis. Let therefore the enterprise produce quantity *OQ*, offered at price *SQ*, *S* being the meeting point of the marginal costs curve *C_m* with the price line *P_s*.

The profit for the enterprise is represented by the area *PSFH*, which is recognised as having the character of a Ricardian income (see AMOROSO, *Economia di mercato [Market economy]*, *op. cit.*) achieved on a turnover equal to *OQSP*.

Let’s now make the two following cases *A* and *B*, in the order of the appearance of the special economic event.

Case A) – Let’s presume that there is an *increase in demand* on the part of the State, in the sense of an increase of *quantities* required and of *price*, which goes from *OP* to *OM*. As a consequence, the new price line for the enterprise being considered is *Mt*.

The enterprise benefits from this favourable event because it supplies the State, which is engaged in satisfying the urgent need of military defence, in the example given here. In fact, producing quantity *ON* at price *TN*, the enterprise will achieve a gross intake of *ONTM*, with profit *MTFH*, which is higher than the preceding one for quantity *MTSP*. If examined closely, this greater profit cannot be entirely considered to have the character of a differential economic income. In fact, on the basis of what has been said before, it is necessary to take into account the greater use of production factors in comparison with the normal period: in Figure 75 it is possible to see the additional cost *QNTS*, to which corresponds profit *STZ*, which can be considered *normal* in a certain sense. Instead, the remaining part of the greater profit, represented by the rectangle *MZSP*, can present to a great extent elements of special economy profits, as it is represented by the greater price obtained on the same quantities of products offered before the war event occurred, and which is here configured as typically relating to the special economic situation.



Figura 75.

Case B) – The character of differential income from the specific economic situation emerges, for the given quantity $MZSP$, even more so when it is presumed that the cause of the greater profit is represented by the increase in the price of the goods produced by the enterprise being considered, at parity of quantity supplied. This applies, for example, in the short term, or when there are constraints to production that can be of various types, both juridical and non-juridical (amount of primary and subsidiary materials used, restrictions on the consumption of motor energy, ban over the use of workforce, even with regard to work timetables, and so on).

Indeed, in this case, the total turnover is represented by the rectangle $OQZM$, with a profit of $MZSFH$, of which the part corresponding to the rectangle $MZSP$ has the character of profit, as it is the difference between price and marginal cost, in order to still comply with the lessons of Amoroso (*Economia di Mercato [Market economy]*, *op. cit.*). Indeed it can be said that the entrepreneur has given no tenders to obtain this differential income, as the structure of costs represented by the curve C_m , whose arc has been intercepted at point S , is unchanged by the hypothesis²⁹⁴.

²⁹⁴ It can be deduced that these arguments of mine are not far from reality or in contradiction with it from the fact that, in the Italian example, with Art. 3 of the Legislative Decree no. 698 of 23 June 1942, the enterprises and bodies taxed on the basis of turnover that could demonstrate having performed *tender and supply* contracts to a greater extent than those performed in the two years before the war (1937–1938), could ask that the ordinary income be determined with *criteria and coefficients of profits* referred to as *prices in the supply in the pre-war base years*. There is, therefore, a reconstruction of the relationship between *net income* and *gross turnover* in the two periods to determine the differential income *exceeding the norm*, assumed as rate (*coefficient*) of *profit* with respect to the *gross income* (price or extent of supplies and tenders).

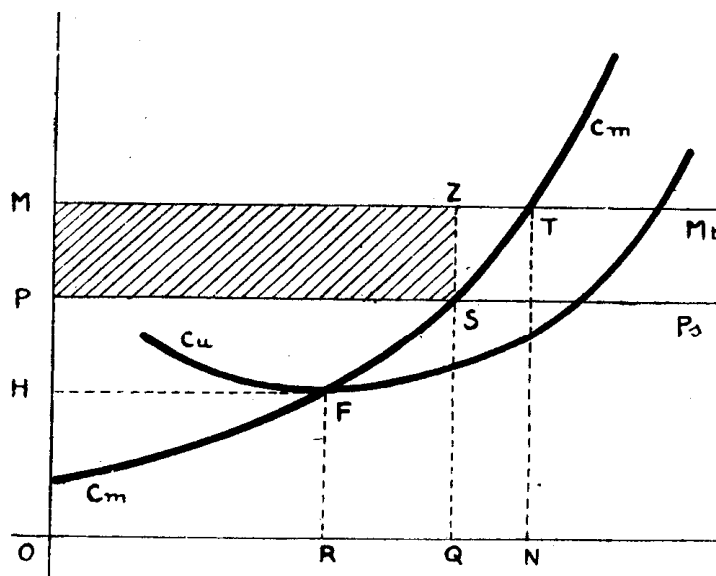
It would really appear that the legislator had wanted to *differentiate* clearly, with the dispositions that are put forward as examples (*case A* from *case B*), which typically are considered in this paragraph. That is to say, to avoid a higher profit being obtained by enterprises supplying the State (which in the normal situation are historically the characteristic subjects of the levy on war profits), or appearing to have been obtained, *all other things being equal*, at *parity of costs*, in other words, a *parity of quantities offered*. This would be *case B*) indicated above, for which only the increase in *prices* achievable for supplies, because of the higher demand on the part of the State, would represent the source of the greater profit.

The same legislative disposition makes reference to what would have been the *profit coefficient* for the *greater quantities supplied*, with respect to the *turnover* (or *total price* of supplies) and seems to represent *case A*, indicated above: that is to say, to take account of the organisational ability of enterprises, as the conditions of both demand and supply change.

In this way the reference of normal income compared to the invested *social capital* in the normal period is overshadowed, and ordinary *income* is referred to as the price (total or *gross turnover*) through “coefficients or criteria ... normally adopted in the base year or years”, taken as terms of reference for the calculation of the

Disregarding the criteria of determination of the object of the extraordinary tax, which we have insisted is given the importance of the subject in practice as well as in theory, in the historico-statistical experience, the special tribute that is typical of extraordinary finance normally represents a limited portion of the extraordinary revenues of war finance. For this *portion*, as in our premise, *the problem of the alternative with the emission of the loan does not arise*, in light of the arguments that give content to the preceding paragraph (on the identity of the pressure of the two sources of extraordinary revenues).

On the other hand, the *increase in tax rates, or the extension of the taxable income of already existing or ordinary tributes* represents a typical case of *extraordinary* taxation to *compare* to the recourse to the *loan* for the purpose of meeting extraordinary expenditure, in terms of its effects or of its pressure. For this second case, for the purpose of illustrating and explaining the real case, the rational references presented in the preceding pages apply.

Of course the governing class can, from its point of view, through “derivations” in the Paretian sense, underline the repercussions of the theoretical reasons, by objectively highlighting them, or obfuscate them by creating “financial illusions”.

V.

VARIOUS TYPES OF PUBLIC DEBT SECURITIES

The forms or types that State debt assumes are various, in particular in function of the factor of *time* in which the restitution of the loaned sums takes place, through the reimbursement or amortization of the same loan.

a) *Treasury bonds* represent the form of debt with the shortest duration. These are considered as true treasury promissory notes bearing the promise to pay the sum indicated on the bond at the expiry date. They can be spread out over twelve months of the year, giving rise to *multi-monthly* treasury bonds, of interest in particular to banks, which invest their cash funds in them.

Then there are *annual* treasury bonds, with advance interest or interest obtained at the start of the term.

Multi-monthly and annual treasury bonds were initially introduced with a temporary *function*, in the context of the annual financial period. That is to say, with the purpose of compensating for “timing” discrepancies or lack of coincidence between revenue and expenditure, during the month of the financial year, as a “fluctuating” or oscillating amount in the context of administration. Strictly speaking, with a balance sheet in equilibrium, at the end of the financial year there should not be any treasury bonds of this type, if they have been issued to provide for temporary treasury cash deficiencies, due precisely to the fact that revenues do not flow into the public offers exactly at the same times as expenditure is incurred.

Furthermore, the First World War and in particular the last one have seen multi-monthly and annual Treasury bonds take on an *exceptional* role, more as medium-term loans, in the sense that with the passing of financial years the absolute amount in bonds has increased. This can be explained by the fact that the balance sheet is not only in deficit but this deficit has also taken on ever growing proportions, with the increase in exceptional expenditure.

The problems of mainly monetary character linked, for example, to this aspect of extraordinary financial policy, relate in particular to the *definitive reimbursement* of the sums that flow towards multi-monthly and annual bonds, which are favoured by individual savers, banks, industrialists and traders over current bank accounts because of the higher interest and their theoretically high degree of liquidity.

Indeed, when the historical period in which it is thought to be convenient to invest in bonds the funds that are available and not used in the economic cycle that was interrupted by the exceptional

surplus or of the war profit or of the greater profits relating to a special economic situation. This order of considerations was overlooked by Steve who also, on a professional basis, analysed the “effects of levies on surplus profits” in the “Studi dell’Università di Pavia” [Studies of the University of Pavia], Garzanti, 1941.

event (for example, war) ends, and the necessity arises of having access to the sums temporarily loaned to the State, if the State has used annual bonds as a non-transitory means of financing extraordinary expenditure, the State will face the need to reimburse enormous amounts, which would significantly increase monetary circulation if the State were to proceed to an integral extinction of the credit of bond holders.

With regard to dangers of the sort that, with inflation, would compromise within certain limits the economic bases of the same production and would affect, through events of wealth distribution, the categories of beneficiaries of income who are traditionally sacrificed by the devaluation of money, governments tend to *convert* annual bonds into medium- and long-term loan notes, in other words, into consolidated irredeemable bonds.

In the Italian experience is included the case of 1926, when annual, five-year and seven-year (with close expiry dates) treasury bonds were compulsorily converted into a new consolidated 5% bond. An analogous criterion was applied in other issues of nine-year bonds such as that of 1952.

Another type of treasury bond that has met with favour of investors for some time, and not only in Italy, is that of *nine-year premium treasury bonds*. In fact they actually pay a nominal (5%) interest to which a small percentage of income (0.36%) is added, as they are issued at a lower issue price (for example 97.50) and are reimbursed after nine years at full face value. They give the right to access to a prize extraction, for each series, of a value that, compared to the nominal value of the series of bonds, represents an average additional return of 0.48%. However, over the consideration of the objective return thus calculated, the prizes confer on these bonds, instead of a subjective value, an "attractiveness" to individuals in the hope that each participant conceives of winning great sums of money that are extracted every six months during the "life" of the nine-year bonds.

b) There are two types of *long-term loans*:

1) those that will be *amortised* or *redeemed*, for which the State budgets an annual sum (usually including both capital and interest) so as to repay the debt according to an amortization plan in a certain given number of years.

It is said that this form of loan corresponds to the needs of insurance companies and in general the needs of financial enterprises that formulate plans and budgets for deadlines spread over time. Of course the State can reserve itself the right to shorten the period of time in which the amortization plan is implemented.

2) Then there is the form of *consolidated* loans in which the State commits itself to pay a given rate of interest in perpetuity, without the obligation to reimburse the capital.

When the State *does not have the obligation* to reimburse the capital and *not even the option* of reimbursement, there is the case of the income in perpetuity (or non-reportable); if instead the State reserves the *option* to reimburse the capital (*without* contracting any *obligation* in this sense), there is a "declarable" perpetual income.

Of course these two types of loan present positive and negative risks for individuals and for the State, depending on the variations of the interest rate that can occur in the market.

The long-term use of capital such as this has lost importance because of the period of monetary instability experienced worldwide, and preference has been given to short- and medium-term securities (bonds).

VI.

THE CONVERSION OF PUBLIC DEBT

Conversion is an operation that tends to reduce the burden for State finance represented by public debt.

1) We have dealt with conversions in the preceding pages from the point of view of the *time* factor. That is to say, in the sense of the substitution of *short-term securities* with *medium- and long-term securities*.

2) It is, however, interesting to consider conversion from the point of view of the *interest rate*, in the sense specified here. First of all, let's keep in mind that we are not referring to *compulsory*

conversions, with which the State imposes on his creditors a reduction in the interest rate, compared with the one agreed at the time of the issue of the public bonds. It is a matter of a partial repudiation of the loan. What we discuss here is referred to as *voluntary* or *optional conversions*.

Let's presume that the State has issued a series of long-term bonds, for example, with a nominal interest rate of 5%. Let's presume that, because of a *favourable set of circumstances* at play in the political economic and fiscal field at a given time and for a given period of time, we observe the trend of the interest rate towards a decrease, for example from 5% to 4% on average for all *homogeneous* employments²⁹⁵, in the market. In this case the State can offer to all 5% bond bearers the following *alternative*: a) the reimbursement of the sum underwritten in the securities; b) or the payment of an interest rate which is no longer 5% but 4% as suggested in the example.

To be able to carry forward this argument, it is necessary for the *market interest rate* to be essentially *lower* than the rate already paid on the bonds to be converted. In this case – as Flora states – the price of the bonds quickly reaches the “conversion point”, indicated *theoretically* by the price corresponding to the capitalisation of their income at the current rate of interest in the market. Therefore only incomes close to the “conversion point” can be converted, and this point (FLORA, *Manuale [Manual]*, 1917, p. 772) is theoretically expressed in the formula:

$$p = \frac{100i}{r}$$

where *i* represents the nominal interest rate of the bond to be converted and *r* the current interest rate in the market. The prices of Treasury bonds on the stock exchange is used to detect whether the “conversion point” (*p*) has been reached or exceeded.

Of course it is necessary that the trend of the interest rate is not temporary or exceptional, and in particular that it is a *spontaneous* trend, “resulting from and at the same time an index of all the variations which take place in the structure and in the economic situation of the country”. Indeed it is necessary that, when offered the reimbursement of the capital, the 5% bond holders cannot use the sum that the State has offered to reimburse at rates higher than 4%. *This is intended to be a parity of risk connected* with the investment in State bonds. There are no long-term controlled or managed reductions of the interest rate in the market, and even recent history (1934–1935) in Italy and other countries registers ephemeral phases of a policy of “cheap money”.

VII

THE AMORTIZATION OF PUBLIC DEBT

Finally we make a brief reference in these lessons to the *amortization* of public debt as one of the operations that relates to its extinction when an expiry date has not been set or when there is no reimbursement plan in place, planned at the time of its emission to meet extraordinary expenditure.

In this field, it is necessary to differentiate *automatic amortization* from *juridical amortization*, in the sense specified below.

I) De Viti De Marco assigned the term *automatic* amortization to the following process. Let's presume that the State, after having issued the loan, does not do anything (juridically) to reimburse it. That is to say, it does not in any way (as there are various procedures, as we will see later) budget for any sum for its *formal* amortization, with the withdrawal and destruction of bonds of its own debt. As the accumulation of savings progresses, this, among other things, is directed towards the investment in State bonds, especially if the priorities of investors who seek modest and safe investments for their savings are considered.

Starting from this premise, what happens is that each purchase of public debt bonds transforms the *burden* that remains charged to the balance sheet of the State as interest on public debt, as a *clearing entry*, and this process is more accentuated the more widely this is done by savers

²⁹⁵ From the point of view of risk.

(producers and workers in the wider sense),: indeed, the *debit of the tax* (for the service of interest) is *offset*, in the balance sheet of investors in these bonds, with the *credit for interest* on the same bonds. If we think of the process of progressive diffusion of State bonds in the portfolios of small and countless savers, this leads to the “democratisation” of public debt. As an effect of this, what the State collects in taxes and what the individual bond holders receive in terms of interest on the public debt bonds become clearing entries, giving rise, in this way, to a *real* extinction of public debt.

“This proposition,” De Viti states, “in its *abstract truth* and in its truth as a *real trend*, demolishes the current view according to which, modern States, because of the enormous amounts they pay in interest, will not be able to sustain this in the long term.”

“Instead, the burden of the loan on the economy of taxpayers is entirely sustained at the moment of subscription, where it has been provided for the payment of relative interest with recourse to ordinary balance sheets. Later, as we move away from the time of emission, the tributary pressure of the loan continuously decreases.”

“The frightening sums of the original public debts and of the interest remain, but the clearing entries gradually remove economic content from these.”

“This phenomenon can be considered as an automatic amortization of public debts.”

However, this vision does not explain the extinction of the debt but the distribution of the pressure, which becomes the same for the loan and taxes charged to the individuals, assuming that they are not able to invest at a higher interest rate.

In terms of overall burden, that of loans decreases as income and savings rise, if the amount of nominal interest remains constant.

II) In spite of the truth contained in De Viti De Marco’s intuition, there exists in the practice of many States a formal *act* of financial policy, different from the process of spontaneous diffusion of titles of public debt among investors of savings. That is to say, there is the destination of taxes (not collected or established for this purpose), to give rise to the *amortization of public debt bonds*. From the point of view of social economy, is the extent of the expenditure that, *all other things being equal*, the State undertakes for the *reduction* of public debt in a *formal* and *juridical* sense indifferent? This was the question I asked myself, considering the publication of the Colwyn Committee Report, whereby a “rapid” amortization of public debt was suggested in the study of the financial problems of the post-war period²⁹⁶.

After having put aside the “derivation” in the Paretian sense, in other words, feelings and moral judgments – drawn from the field of the relationships between private individuals and mistakenly extended to the field of public finance – on the behaviour the State should comply with in terms of amortization of public debt, I pointed out – having found no similar observation or demonstration in the past – *that it was again a matter of the classic problem of the identity or the different pressures of the loan or tax* (which we discussed in paragraph III).

[I was satisfied to notice that it was indeed Borgatta who claimed the same conclusion as I did, which takes us back to Ricardo’s theory. I wrote along these lines in 1933, before Keynes generalised the “income economy”, in other words, the solutions of mass problems based on the repercussions that the procedures hypothesised exercise, ultimately, on the variables represented by the income of a country or market, considered overall. When dealing with problems of traditional financial economy and of the Keynesian theory, the amortization of public debt can be placed alongside the examples I drew from (in the lesson I held at the faculty of law in Paris, published on the “Reveu de science et de législation financière” [Financial science and legislation review], 1951). In fact I have considered this as a mass problem since 1933, and not in an atomistic sense].

In fact, if in a given time (*t*) in theory and in practice, it was believed to be preferable to make recourse, within certain limits, to loans to meet an extraordinary expenditure (instead of an extraordinary tax), and if at a second point in time the immediate restitution or prompt reimbursement or amortization of the public loan is demanded, must it be presumed that there exist at that time (time *t'*) conditions such as to lead to the belief that the actual collection of the tax for the total or partial

²⁹⁶ E. D’ALBERGO: *On the utility of a “rapid” amortisation of public debt*, “Economist Journal”, April 1933.

reimbursement of “capital” is overall *less costly* for society than the payment, presumed to be perpetual, of interest?

In other words, let's presume the existence of a certain amount of internal public debt; this, *all other things being equal*, means that at a given time (t) it was thought convenient to *prefer*, within the limits of the amount of the debt considered, this form of extraordinary revenue, the extraordinary tax, to meet an extraordinary expenditure. If at a later time (t'), which in practice in the typical case coincides with the post-war years, it seems to be more convenient and less costly for the community: a) to collect an extraordinary tax to reimburse the debt in one go; b) to destine ordinary taxes to the gradual amortization of public debt; this means that at time (t') the collection of a certain determined amount of tax and the destination to the amortization of debt imply a lower economic cost for the community than that involved in the permanence of the debt and of the burden of interest that this imposes on the same community. This is generally taken for granted – I wrote at the time – (or at least it should be so considered) when the immediate or rapid amortization of public debt is required, when the circumstances that had determined the extraordinary expenditure have changed.

After various clarifications I reached the conclusion that, *from the point of view of the maximum utility for the community, as a unity, there is convenience in the amortization of the public debt, in the extent to which the transformation of capital and the uses that it determines give rise to the production of a social income higher than that which could be achieved when the effects of the permanence of a high level of public debt persist. Amortization could be as rapid as the cost that it implies for the community through the transformation of capital and of uses, and the increase in the tax interest is overtaken by the economic utility that the community achieves, in approximating the position of equilibrium in which the distribution of the uses is the most productive, not in an absolute sense but all other things being equal, in comparison with that which applies at the moment in which the existence of a certain amount of public debt that needs to be reimbursed is considered.*

It does not matter that it is difficult in practice, given the concurrence of circumstances here presumed to be unchanged, to use these conclusive arguments: however, in the limits in which a theoretical conclusion applies for practical purposes, it seems that the current hypothetical approach makes the problem *more determined* than it would have been without the “derivations” quoted in my essay with regard to the opportunity to proceed to a more or less “rapid” amortization of public debt, or under the conditions applied by Ricardo and reformulated by Keynes (destination of the subs reimbursed by the State, for *productive* purposes), or formulated by Seligman or by Pigou and other authors or, ultimately, the conditions listed with limited scientific rigour in the Colwyn Report.

In dealing with this subject, even when taking account of the existence of De Viti's concept, I explained with good reasons (E. D'ALBERGO: *Sull'utilità di un "rapido" ammortamento del debito pubblico [On the utility of a "rapid" amortization of public debt]*, in “Giornale degli Economisti” [Economist Journal], *op. cit.*) that the problem of the *spontaneous* diffusion of bonds on the market, through the independent “choice” of investors of savings or of capital freed by other uses, is different from the process, in contrast defined as “affected”, of the compulsive destination by the State of taxes when withdrawing public debt bonds.

Indeed, individual subjects, in whose balance sheets a *clearing entry* has taken place for the payment of interest and taxes, hypothetically, have freely or spontaneously disposed of their own investment, in such a way as to obtain the maximum utility or net income (also in terms of risks), considered from the atomistic private point of view.

Einaudi, who gives a clear exemplificative explanation of De Viti's automatic amortization, referring to historical examples²⁹⁷, rightly called *private* amortization what is performed, in fact, with

²⁹⁷ Einaudi's Note (*Principii [Principles]*, 1940 edition, p. 458):

“In older States, before 1789, legislators had realised the vanity of writing and passing cards, amounts, notices and vouchers, and had conceived an obvious solution. The treasury would give creditor One a sort of delegation to obtain payment of 4,000 units (for interest at 4% on 100,000 units) from creditor Two who had a debt for a similar land tax. When creditor Two was tired of paying, he would redeem, paying 100,000 units, the delegation and would pay 4,000 units to himself. That is to say, he stopped paying. The rate (the name of the land tax in Piedmont before 1789) had ceased with regard to himself and the public debt was cancelled, with respect to the portion he was responsible for.

the private purchase of public debt bonds on the part of debtors of the tax necessary to service the loan. Indeed this initiative takes place in the limits in which the taxpayers have the possibility and the *convenience* of providing the extinction. If creditor Two has saved²⁹⁸ or has cashed in previous savings, to purchase public debt bonds, assuming the “double role” of the State taxpayer and creditor, at the parity of the sum of income and tribute, this is presumed to have been done when the return from the public bond represents the *maximum* obtainable income from his private point of view.

“If, when saving, he *does not* purchase public debt bonds but industrial securities or land or houses, he has in his own judgment a greater income or benefit than that which he would have had by privately amortising his portion of public debt. Every day, at the beginning as well as later, the taxpayer makes and continuously renews his choice between two methods, according to the rule of his maximum convenience.”

So wrote Einaudi, identifying the individual point of view or by arguing in atomistic terms on the probable basis of the known presumption that, with everybody behaving freely in the same, most economic, manner, there should be proof of the overall maximum income (real and monetary) for the community.

However, the problem that I had, before the current Keynesian vision, set up as a mass problem, in function of the overall variable represented by social income – net of the collective cost determined by the redistribution of uses and by the increase in the interest rate – derives in reality from the fact that an external force, compulsory in respect of the choices made by individuals, is that which the governing classes put in place with the “fictitious” amortization of public debt. The redistribution of uses determined by the collection of taxes and the destination to the reimbursement of public debt is compulsory and may not coincide with that which would have spontaneously formed in the market. It is not the task of the academic to ask what are the complex reasons that can induce the governing class to plan the amortization of public debt within certain limits (for example, the mistaken analogy with the behaviour of private debtors, the purpose of increasing the State credit in view of future issues, etc.). However, admitting a certain decision, from the strictly economic point of view, which is the only one taken in these lessons, the theoretician suggests the variation of the national dividend or social income as a variable of the index of convenience of proceeding or otherwise, in terms of quantity and time, to the amortization.

This study relative to the solution (public amortization) *independent* from that which private individuals would spontaneously choose, as I have reconfirmed (in the article: E. D'ALBERGO *Sulla scelta e sul contenuto economico dei sistemi giuridici d'ammortamento del debito pubblico* [On the choice and content of juridical systems of amortization of public debt], in “Giornale degli Economisti” [Economist Journal], 1934), presents itself as a “problem founded on the effects of transfers of wealth among *different subjects*, implicit in the process of amortization and on the convenience or otherwise of determining them” from the point of view of the maximum economic utility for the community, as judged by the governing class, in the sense indicated earlier.

The logical legitimacy for this study has been established by the same De Viti De Marco when he writes that the loan gives rise to a State “clearing entry” when the balance sheet is charged with the sum for interest to which corresponds an entry for the same amount. This “is not so in the economic balance sheet of the community, as it has sometimes been stated,” warns the illustrious author. This is so because the community is not a homogeneous entity, which pays 50 million in taxes

What was a clear and simple fact in Piedmont in the 18th century, now is a theory carrying the name of Antonio De Viti De Marco.”

Let's now replace Einaudi's expression (“tired”) with that which is used in the context of the rest of the treatise, in which there is discussion about “convenience”, with the appropriate one (“had the convenience”), and we have the logical basis of the spontaneous solution to the problem from a private and atomistic point of view.

²⁹⁸ It is possible to agree with Borgatta, when he states that the *new* savings invested in bonds lead to the *lightening* of the debt, because the relationship between *a*) the levies necessary for the service of interest or the possible amortisation, and *b*) the total income of taxpayers, decreases – at the parity of the level of public debt or if this increases less than the national or social income. That is to say, we talk of *pressure* over time rather than of automatic amortisation of the debt.

and receives 50 million in interest; the State receives 50 million in taxes from some and pays 50 million in interest to others (*Principii [Principles]*, Chapter XXIX, on the theory of public loans. However, he writes this about the genesis of debt and *not* about its extinction).

It was for this reason that I believed De Viti's theory to be "not adequate to the solution of problems having correspondence in real examples" with regard to amortization.

The problem can be made more complicated (as was the case when I wrote in the "Giornale degli Economisti" [Economist Journal] about some financial effects of amortization) by taking into account the different inclinations towards savings and towards consumption of those from whom purchasing power is taken away with the imposition and those to whom it is returned by means of amortization by the State initiative. This and other complications are not within the scope of this course of lessons but of that of monographical, more in-depth analyses.

III) Another warning relates to the *procedures* for the amortization of public debt²⁹⁹. Regarding this, the systems adopted in more advanced countries can be summarised as follows:

1) Destination and amortization of public debt of:

a) a fixed or variable portion of the overall revenues in the balance sheet;

b) surpluses or excesses in revenues for public expenditure;

c) a combination of a) and b);

d) revenue from a particular source of income, in other words, from one or more specific tributes;

2) The alternatives indicated in the points a–d without distribution of bonds and with the use of their income at a compounded interest;

3) Allocation of a percentage of specific expenditure items (but not of total public expenditure);

4) Allocation in the budget of a sum corresponding to a percentage of the overall amount of the outstanding debt;

5) Issue of new loans to pay off previous ones.

If we wanted to answer the question about which is the best procedure for amortization, the answer cannot be univocal because, in addition to the specific effects of the different technical (qualitative) systems or procedures, there is the diversity of the economic and sociological environment conditions in which these systems operate, in various countries and times. Such typical conditions have been considered in a detailed way in my just quoted essay.

The procedures indicated are justified as *coexistent with automatic amortization* indicated by De Viti, as has been seen. Indeed, he admits that the State can contribute to the extinction of the debt by making recourse to the procedure suggested by Hamilton, of allocating *budget surpluses* to this purpose. "Proceeding in this way," De Viti writes, "the public loan would *in fact* be annulled and also *formally* reduced in quantitative terms." The two solutions can be integrated, even though they are independent (automatic and juridical amortization).

Making reference to the systems indicated above, it can be said that *juridical* amortization corresponds to *actual* amortization, not only when there are *surpluses* in the revenue for current expenditure but also when *revenues* exceed the budgeted expenditure for items other than those allocated for the purchase of public debt bonds. That is to say, there is a significant amortization even when the State balance sheet *breaks even* and there is an item on the debt side for the purchase of bonds with allocation of revenues according to systems 1) a and d, 3) and 4).

IV) A *significant* (not formal) reduction of public debt and of its burden from the point of view of the State is implemented through *monetary devaluation* when, among other things, the cause of the decrease in value is due to the circumstance whereby the State has made recourse to *the issue of currency* to meet part of the exceptional expenditure.

It is indicated in the monetary laws of various countries that the issuing institutes can make advances to the State treasury, within *statutory limits*, in normal times and according to the needs of

²⁹⁹ E. D'ALBERGO: *Sulla scelta e sul contenuto economico dei sistemi giuridici di ammortamento del debito pubblico [On the choice and economic content of judicial systems in amortisation of public debt]*, in "Giornale degli economisti [Economist Journal]", August 1934, *op. cit.*

the treasury. When, as happened in the First World War and in part also during the last conflict, the State asks for advances in excess of statutory ones and gives rise to the *additional issue* of notes on the market, this determines an increase in prices and the simultaneous reduction of the purchasing power of the same currency.

In this way the State obtains a *loan without interest*, and through the devaluation of money it collects a portion of assets from those who had invested them in fixed-income assets. Among these are holders of public debt bonds, who see the purchasing power of the nominal value of the bonds and the nominal return of the same bonds devalued. Generally speaking, if tributary revenues and the burden of the service of interest at times in which public debt was issued for a certain amount with the revenues and burden of a subsequent time, after the monetary devaluation and its relative increase in prices, it can be observed that - at parity of tributary or legislative system - revenues increase while the burden of interest either stays the same or increases by less. It follows from this that, almost *without further formal tributary burdens* (increase in rates or taxes), the State can service the interest for an even greater debt. As can be seen, monetary devaluation acts *by in practice annulling* a great part of public debt, even though it still formally exists on the market. It is necessary to reverse considerations in part when discussing hypotheses of monetary revaluation.

Academics - among which it is a surprise to find De Viti De Marco, as Cabiati observed (writing about this in the "Giornale degli Economisti" [Economist Journal] after the publication of my study on the amortization of public debt) - have suggested, as some humanitarians and politicians generally have done, the need to re-evaluate the currency to do justice to bond holders. (Generally to holders of fixed-income bonds or bonds inadequate for monetary devaluation.)

Clearly, over time, the conditions of equilibrium have changed (see the logic of my theory on *Sgravi fiscali [Tax rebates]*, which precedes this), so that, even though they might be willing, it is not possible to re-establish holders of bonds and taxpayers in terms of the initial conditions.

However, the processes of redistribution of wealth that are implicit in a revaluation (as in monetary devaluation), according to theory and general experience, end up damaging the producers of new wealth. In this way, to neutralise losses, as imbalances between the high or rigid costs and reduced revenues affecting the category of producers (and sometimes savers with bank rescue packages??), new tributes are introduced that also affect those who it is intended to favour with the monetary revaluation (bond holders).

Generally, the national income is reduced and can theoretically be reduced in a relative way, and this variable is a warning as to the advantage for the community of monetary revaluations or of the efforts, which it is attempted to impose on States to maintain the gold-clauses that characterise some old and new loans. Indeed, to maintain the promise towards the holders of "gold bonds", it would be necessary in the case of monetary devaluation to redistribute a great part of the wealth of individual countries. This explains why gold-clauses are abolished in public loans, specifically in the general interest, from the point of view of the advantage of the community and not only for the prevailing (political) forces of debtor and taxpayer groups.

VIII.

THE PROBLEM OF THE "LIMITS" OF PUBLIC DEBT.

It is a problem that recent theory should not have had to set, after the scientific criticism that has emptied of content what was defined as a mirage, an illusion or chimerical hope. That is to say, after the dreams of the inventors of cash funds for the amortization of public debt were reduced to the role of arithmetic calculations, devoid of realistic economic content.

Italians, as Flora recalls (in the *Manuale [Manual]*, in the chapter on public debt), assign the merit of the discovery to the Genoese Antonio Grimaldi, the French to the Paris brothers. As I have recalled in the quoted essays, Dr Price conceived a plan of public debt amortization of the utmost simplicity and without apparent heavy cost to the community or prohibitive difficulties in implementation in England.

The mathematical criterion, which could be called the game – in this case with irony – of the compounded interest is known. According to this it would be sufficient to supply an amortization fund with an annual amount, even if small, for example 1 million, of a certain amount of debt, for example 100 million, paying the interest on this amount (for example 5%) in order to, on the basis of the presumed numerical data, abolish the State debt in about three generations. It is sufficient to adapt the calculation of current public debt and other figures that are rapidly increasing and conceivably “high” (if not actually tending to infinity as in a paradoxical way some of the German economists quoted in this chapter have presumed) to find the easy and illusory solution of the amortization of very high and tremendous sums of public debt.

The paralysis of the English Sinking Fund and of similar funds in other countries should have led to the fall of illusory hopes, in light of the realistic variable that can allow the service (interest) and the reimbursement (extinction of the capital debt) of public loans: it is the income or the wealth of a country or market or State in which the problem arises.

If it is true that the “burden of the loan on the economy of taxpayers is entirely sustained at the moment of subscription, where it has been provided to the payment of relative interest with ordinary balance sheet recourses” (De Viti De Marco, who in this sense is the spokesperson for the general obvious theory), the limit of the public debt has already been identified in the quantity of income that can be detracted from the taxpayers making up the community for the service of the loan. Even when debtors for the taxes and creditors for the interest partially coincide, there exists a limit to the allocation of savings to bonds and of the corresponding tax for the service of interest; there is also a limit to the redistribution of the income for the service of interest by collecting taxes from some and allocating, in the State budget, expenditure to interest, to be paid to other members of the community.

The problem of the limit of public debt, referred to as the moment of its issue, arises in an apparent, immediate and implicit manner if we think about amortization, in other words, the extinction of the debt.

The question of *degree* that, as has been seen, is restated at every step, in the treatment of problems of extraordinary finance arising from the budget deficit against expenditure exceeding standard levels in financial economy, dominates the arguments, as in the case for example of tributary pressure. However, many authors have left the problem undetermined, when they have generally suggested the *standard way to perform* according to which it would be “useful” for the State not to contract “excessive” debts. There is often a lack of a term of reference in this field. And when considering the statements of undetermined value, observed in the quoted essay of 1933, that no quantitative measure can be “placed at the maximum limit of public debt”, there is no reference to the variable represented by social income. As I was also dealing with partial extinction, I was interested in studying the effects that a more or less “rapid”, or relevant over time, reimbursement of public debt can determine on the level of social income with respect to the level of given starting points, before the amortization.

It is necessary to say to those who, especially among German economists, have thought they were bringing new and paradoxical arguments into this field, that the limit of debt was already to be found in expressions that, even though they focused on the domain of the appropriate vision of the problem, appeared to be undetermined or vague to the academics and experts of the *Colwyn Committee* in 1927. I recall two to whom I made reference in my quoted essay: “The amount of wealth to be allocated to the amortization of debt should not be more than the amount of savings of the nation, which remain after having provided to State expenditure for the increase of capital for the increasing population, for the replacement of capital lost in war, to provide capital for new enterprises, to increase the standard of living.” Others thought that “the portion of national income that remains after ensuring the development of national production should be considered to be available for amortization”.

Reporting this economic category in this field, a *limit* to the import of public debt is implicitly found. Referring gradual reimbursements of loans to the extent of social income, another variable has been identified, which acts as a limit not only to the service of interest but also to partial reimbursement; similarly extraordinary taxes or “levers” on capital find a limit in social wealth also monetarily mobilisable.

By identifying the other expenditure that the State must simultaneously meet for the satisfaction of public needs over the time in which this financial problem is considered, we add to the argument another more immediate or lower limit than the one represented by the amount of income or assets of a country. That is to say, reference is made to the operation of the economic law that dominates, according to Pantaleoni, the distribution of public expenditure that requires the consideration of ultimate degrees of utility inherent in each combination that can be formed with possible expenditure, in the mind of the legislator, in order that the final degree of utility of every item of expenditure, at parity of amount, is equal to any other.

Finally, the maximum social income variable has implicit within itself not only the limiting need of the reconstitution of capital for production; however, as social income, that is to say, referred to as a given *societas* and population that makes it up, contains the abstract limit (that history each time translates into absolute value) such as Borgatta had placed as a limit to debt, that is to say, a minimum income for sustenance. As we are dealing with problems in which distributable income is of interest in addition to the maximum producible collective income, it is necessary to think about the limit represented by the minimum for subsistence, after the collection of taxes for the service of interest or the reimbursement of the loan has been charged to them.

This type of argument, even in terms of the part that could appear to be implicit, such as the one that appeared in my aforementioned essays, was highlighted by Villani³⁰⁰, who has recalled also the illusion of the pretension of German academics quoted above in the field of the inexistence of *technical* limits for debt. Even when the monetary event (inflation) modifies the limits of debt, as it is a matter of relationship between State debt with private individuals in terms of money, in practice this modification of *degree* (another confirmation of my logical approach to extraordinary finance) cannot hide under the *monetary veil* the reality that the theoretician and the historian identify in the long term. That is to say, that in the end it is always *real* income that acts as a limit (in terms of *flow*) to the service of interest and, ultimately to the extinction of the public debt, as a shifting (capitalisation) into a *fund*.

As the inventors of the Sinking Fund failed when they forgot that the amazing game of figures of compounded interest must logically correspond to the production of greater income or a corresponding wealth to be distributed, so the academics who did not see any limit to debt, in the bloom of the literature of the last world war, have neglected the same abstract variable that determines the theoretical problem, with the quantitative adjustments that each time the real event requires, in the individual countries. As I have recalled the German academics, with Jecht among them, it is necessary to note this theoretical example. Even though it was through brief references (in Chapter V of *Kriegsfinanzen [War Finance]*, G. Fischer, Jena, 1938), he saw the possibility of debt dependent on the amount of newly formed capital or capital that would become *available* on the market during the war; from the need to allocate a part of monetary capital to other economic purposes; from the inclination towards investment in bonds on the part of holders of monetary capital, from the compatibility of the allocation of fiscal revenues to interest, with other allocation of the national income to private investment and consumption.

IX.

“THE CIRCUIT OF CAPITAL” FOR THE FINANCING OF WAR WITHOUT INFLATION

While the position of these academics has been generally accepted and spread in their works in the field of theory and financial history, on the occasion of the last war the conviction was

³⁰⁰ In *Saggio sui limiti dell'indebitamento statale [Essay on the limits of State debt]*, Rome, Istituto Poligrafico, 1947.

mistakenly formed that some economists had changed their mind, suggesting the convenience of a *portion of inflation* in the context of the financing of the war.

There was a reaction against this opinion, for example, in Italy from economists who, especially in the case of Borgatta's work, have differentiated between the claim and the *unsustainable idea* of the *opportunity* of a partial widening of monetary circulation in the interest of the State treasury, and the technical *explanation* of a general *event* such as what *inevitably* happened in particular because of the lack of foresight on the part of governments or of political-psychological factors: that is to say, the nearly general recourse, in the experience of this war, in various proportions to the anticipation of payment means in favour of State treasuries, granted by the issuing institutions.

In light of the theory acquired, there has been an attempt to identify what might be the *benefits* of the recourse, at least in part, to the issue of *new* or additional *means of payment*, considering the question *from the point of view of the State*.

Among the presumable factors that might have made the partial recourse to the anticipation of means of payment on the part of central banks advisable and, sometimes, inevitable are the following ones³⁰¹:

a) From the *temporal* point of view, given the *sudden onset of the need* to be satisfied (the typical example can be not only war, but also flooding, epidemics, earthquakes, famines, economic crises, etc.), public expenditure can increase to such an extent that traditional means to fund it can become inadequate in the period of time in which it is necessary to meet the same expenditure. In this case the most *rapid* and prompt manner to obtain treasury income is that of the extraordinary advance of means of payment on the part of the issuing institutes. This also avoids the waiting for tributary revenues that, as they are proportionate to ordinary needs, are insufficient for the purpose of the satisfaction of new needs that require significant expenditure. Similarly, it would not be possible to wait for the analysis and application of extraordinary taxes nor, in some cases, the issue of loans in the traditional forms of the issue on the market of State bonds. Furthermore, the issue of banknotes avoids the burden of interest.

b) From the unilateral point of view considered (the point of view of the State), as has been previously seen (with regard to the amortization of public debts), monetary *inflation attenuates the burden* on the balance sheet of *interest* and *capital* of previous outstanding bonds for *loans*; the same can be said of the decrease in the pressure on the State budget with regard to deferred *yearly payments* and State *contributions* that continue into the future, and of *stipends* and *pensions* that do not vary in proportion with the level of prices.

c) With the instrument of inflation, the State reduces the *consumption* of private individuals by expanding its own: 1) first of all, by increasing the price of the goods that the State, provided with new purchasing power, can purchase in competition with private individuals on the market; 2) in second place because, in the case of those whose income does not increase in monetary terms in the same proportion in which prices increase, there is renunciation to savings in addition to renunciation of real consumption of some goods. Indeed consumed quantities are reduced when the rate of increase of monetary income is lower than the rate of increase in the level of prices of direct goods; 3) in third place, consumption can be compulsorily reduced through bans of sales, rationing and, generally, the limitation of the quantities produced and available for consumption by private individuals, who benefit from the increase in monetary incomes with a rate of increment higher than that of the level of prices or who see their own incomes increase in the same proportions, in nominal or monetary terms, as the level of prices.

If the reasons at points *a)*, *b)* and *c)* can, in the interest of the State, and from a unilateral point of view, lead to the belief that an expansion of means of payment is convenient, there are *unfavourable* influences both with respect to the same State finance and the wellbeing of the community and the efficiency of the productive economy, that may neutralise the benefits indicated above.

³⁰¹ See the quoted article by Borgatta, published in the December 1943 issue of the "Notiziario Economico" [Economy news] of the Milan Saving Bank.

Among the *unfavourable* circumstances of inflation, even if partial, it is necessary to consider, as indicated in the quoted article:

A) The delay or the slowness with which the revenue from tributes increases with respect to the increase of the level of prices and of the national monetary income. From the disproportion between revenues and expenditure, which are stimulated, with their increases in nominal terms by the increase in prices, arises the need for further issues of means of payment when the loans cannot meet immediately and in an adequate manner the needs of State expenditure.

B) The capacity to create new monetary savings becomes *affected* partly in those categories of beneficiaries of income who appeared to be advantaged by inflation at first, that is to say, before prices in rapid increase neutralise at a later date the differential margin or the advantage that derives in a first instance from the divergence between: 1) the rate of increase in prices; 2) the rate of increase in monetary terms in the initial period of inflation.

C) The excessive reduction in *consumption*, in the categories damaged by inflation, due to the recalled divergence between the rate of increase in prices and the (lower) rate of increase of monetary incomes of some categories of beneficiaries of income. This lowering of the standard of living can compromise the *capacity* to work of large categories of production workers.

D) Finally, this latter can be *disorganised* by the imbalances that occur because of the decrease in savings, the consumption of pre-existing capital (spare provisions, machinery without adequate amortization), and generally the disturbances that the inflationary crisis determines in production systems, as the German experience of the First World War indicated. The reduction in the values of securities that reflected the *productivity* of industrial enterprises was a significant index of this, a reduction which could be evaluated by comparing the price of gold in the period before the war and in 1923.

For these reasons, which can be identified in part in the synthetic article by Borgatta, and for other conceivable ones, even if recent experience has highlighted the recourse within non-indifferent limits (Germany, United States, England, Italy) to the exceptional issue of currency by the issuing bank, we must conclude by confirming the unchallenged current doctrine. That is to say, that the recourse, even in the *first phase* of the process of satisfying an extraordinary need, to *monetary* emission must be considered the *worst instrument* or the means to be used with caution and as a “last resort”, among those that have been considered for the financing of a war, as the most important example of extraordinary expenditure.

To *neutralise* and, even better, limit the effects of the inevitable issue of additional payment means, even if at the initial stage, and to contain monetary inflation, an attempt has been made to compile a set of measures suitable to reduce the same inflation. That is to say, the so-called technique of *circuit of capital* or “monetary circuit”, of which academics in various countries wrote on occasion of the last war, was devised.

Dealing with the Italian case in 1940³⁰² with the purpose of including it in the traditional theory, in other words, in the financial logic established in well-known essays of the past – having as its object mass phenomena and not atomistic analysis – I wrote that reference was made “under new definitions” (circuit of capital) to the results relating to the recent experience (the previous world war), adapting them to new historical events. With this I intended to remove the “*novelty*” halo in the field of *logic* from the notion that synthesises the policy of war financing without incurring the inconveniences of inflation: that is to say, to *deny* the status of “*new* monetary theories” to the essays that supported or explained the technique of the mentioned circuit.

Two years later I read with interest, in the quoted article by Borgatta, who had considered the various opinions expressed with regard to this both in Italy and abroad, that the technique of the circuit of capital is not far from the suggestions advanced by L. Einaudi in his well-known essays commenting on the events of the previous war. Indeed, Borgatta observed, in retrospect, that it was possible avoid the extensive recourse to the issue of banknotes on the part of the State, if governments could, during the war years, increase tributary pressure in addition to resorting to loans. So, there is *nothing new* in the concept of the circuit of capital with regard to the limitation or the

³⁰² See E. D'ALBERGO, “*Rivista Bancaria*” [*Banking Review*], November.

reduction of private consumption and the allocation of available funds, which the same extraordinary expenditure creates or whose growth it contributes to, to the financing of recurring flows of extraordinary expenditure.

Having said this, the “circuit” can be defined as a technical procedure aiming to ensure the *reflux* (returning circuit) to the State treasury of the money or monetary capital put in circulation through the relevant State expenditure, with the purpose of avoiding the renewal of the same expenditure making necessary further issues or *additional payment means* on the market.

In 1940 I listed the following among the premises necessary to realise the logical functioning of the circuit: *a)* the maintenance, as long as it is possible, of *stable* price levels; *b)* the *limitation of consumption* of direct goods; *c)* the *compulsory* collection, with direct and indirect taxes, of a part of the incomes as soon as they are produced or as soon as they are aimed at the consumption of taxed (or taxable) goods. The monetary savings so formed or aided in its formation, “could” therefore flow to the State through the underwriting of loans and of collection of greater tributes.

As there is *no certainty* of the flow or rather the *reflux* of available capital – which, through the measures indicated in points *a)*, *b)* and *c)* above, are formed in the market – *towards* the spontaneous *use* towards *State bonds*, it is necessary to *prevent* and *hinder* “free” monetary capital from being used towards instrumental goods and moveable and immovable assets *other than State bonds*.

(A sufficient guarantee that available capital is going to be largely invested in State bonds is when the same available capital flows to banks in the form of deposits; indeed the statistics of many countries, including Italy, indicate that new capital available to banks is used mainly towards State bonds of different types during war.)

To avoid the arising of doubt in the mind of students with regard to what precedes and, in particular, to eliminate contradictions, I will recall that the circuit of capital *is not* a process that is *subject to criticism* because it is in contrast with experience, in the sense that it – as has been said – has pointed out the recourse on the part of many governments also to the issue of additional payment means.

Even admitting that there might be an *initial additional issue* of payment means (a fact that can be empirically ascertained), can it be *logically* said that it is not possible to speak of the efficient and coherent functioning of the circuit of monetary capital?

The answer to this was that the “circuit”, as a logical problem, can be conceived in the sense of the *limitation* of the *margin* of new or greater expenditure to be met with the expansion of money and credit circulation rather than as an *absolute* problem of the *elimination* of the injection of capital already issued in the initial phase of the war. That is to say, while there may be *practical* reasons for the difficult *functioning* of the circuit, there are no *logical* reasons that totally oppose the functioning of the circuit.

Indeed, having made the hypothesis of an *initial* increase in means of payment, it is clear (Borgatta) that even if in the following *units of time* the circuit functions perfectly and manages to provide for the subsequent extraordinary expenditure, with taxes and loans, the *initial* supplement in the circulation is immediately issued to the market again and modifies in a lasting manner the relationships between money and goods (inflation). The hypothesis of initial *inflation* tends to *recur* in the course of the war every time that State expenditure experiences a sudden and significant increase that is not able to be met out of capital previously issued. Every time, the (return) circulation intervenes after a new expansion of payment means to avoid public expenditure causing new expansion of circulation in subsequent times; however, every time that the *initial portions* are *added* to the pre-existing circulation, they progressively increase the *overall* amount. That is to say, it is not enough that the circuit allows most of the money issued over time to be *returned* to the State treasury, so as to meet subsequent extraordinary expenditure without further increases in circulation. It would be necessary that, after the first increase in circulation, and at ever subsequent *increases* in the State expenditure, the treasury’s *intake would be greater than* the payments to the extent necessary to *meet* all the *additional* extraordinary expenditure and also to *withdraw* (or reduce) the *previous* excess in circulation.

The “normal” functioning *does not* avoid, therefore, a gradual *increment of the overall circulation* during the war; the rational functioning would require not only a progressive compression

of private consumption and an increase in the portion of income saved or used in the payment of tributes but also an exceptional and *additional restriction to consumption* and an *increase in savings* (invested in loans) in each period following an increase in the State expenditure, which in *practice* would seem to be *difficult* to obtain, due to the numerous real conflicts. The essential problem of the circuit after the initial phase is that of reducing to the minimum the recourse to *new* issues in the periods of increase in the war expenditure and withdrawing this in the periods of stability in the State expenditure.

I have extensively reported Borgatta's argument, who responded in this way to the criticisms that can be put forward against the logic of the circuit. These observations, put forward by other authors (such as Federici and Cinquini, who have put into symbols the arguments arising from the hypotheses of concrete divergence between the times in which the issue of money takes place and the times when this money is recovered through the circuit) *do not affect the rationality of the idea*, but relate to the *operation* of the circuit. If a *perfect* operation was required, it would be necessary to be able to *forecast* the future *variations* of public *expenditure* and plan for *means of payment* to avoid the *issue* of additional currency at the time of the *increase* in expenditure. It would in any case be necessary to *reduce the intervals* of time between the State payments and the recovery of the sums issued on the market.

Federici considered the recourse to taxes as more suitable than loans to avoid the additional issue of banknotes on the market by the State. However, he saw tributes as a mechanism working "in jerks", most likely because – I believe – reference has been made to *direct* taxes, which also confer on the State intakes a bimonthly regularity that cannot be properly said to be characterised by perceptible jumps even without the same continuity that characterises the flow of expenditure. However, direct taxes are only one aspect and a relatively minor one, in terms of State revenue, compared to *indirect* taxes on transfers and in particular on *consumption*, that is to say, compared to fiscal institutes that have the benefit of the *continuity* of flow, as they are proportional and are assessed and collected at the same time as events collectively continuous such as transfers of moveable and immovable assets and in particular consumption of direct goods.

What has been reported also presumes that the *premises* indicated above, which relate to the policy that is not only financial but also relates to *rationing* and *prices*, are perfectly realised for the purpose of the effective *limitation of consumption* and *investments*, because the formation of monetary reserves not absorbed by private consumption and uses can be put at the disposal of the State through tributes and loans.

With regard to impediments and hindrance to investments in moveable and immovable assets, an objection has been put forward with regard to the logic of the measures that (like the special Italian stamp duty on the surplus value of property assets and the extraordinary tax on securities, etc.) aim to be a hindrance to the use of capital in assets other than government bonds.

That is to say, that also those who *obtain money* for the *sale* of moveable or immovable assets have at their disposal a sum (revenue) that, directly or through bank deposits, can be allocated to be used in government bonds. However, all that is put forward as examples *following* the trade can indeed take place but *after* a certain period of *time*, during which time the treasury remains short of adequate available funds while in fact hoping that *ultimately* the revenue deriving from the sale of moveable and immovable assets will eventually find their way into the investment of *government bonds*. During the period of shortage, presuming that an exceptional public expenditure arises, the State must make recourse to the issuing bank for the *additional amounts*, if there are no other adequate treasury revenues. That is to say, the time factor (in which the hypothesised and definitive allocation of revenues from sales of moveable and immovable assets to be used in government bonds) gives rise to a quantitative *imbalance* (between public expenditure and the means available to the treasury), an imbalance in which lies the genesis of the additional issue of banknotes on behalf of the State on the part of the issuing institutes. It is furthermore to be noted that when the trend of uses indicates a propensity towards *private capital goods*, there is no "certainty" that the revenues from sales and purchases will be used to purchase government bonds or to be deposited in bank accounts. It is, however, to be presumed that a great part of the revenues will be *destined* for qualitatively different objectives from the initial one from which they are derived due to liquidation of investments (in

particular with regard to property assets: land or houses, old or new, urban or rural houses, etc.; that is to say, the type of actions owned before and new type desired, etc.); but quantitatively *still* represented by assets of a *private* character and not *public* debt bonds.

From these arguments derives the rationality of tributes that prevent investment in private assets in times of war, at the same time providing a revenue for the State, if these taxes are appropriately devised. In this way other non-fiscal provisions with the same objective can be explained.

In addition to this obstacle, which indirectly causes investments in government bonds, there are rules that *constrain*, in various countries, a part of the revenue or of the *income* both in relation to direct investment in public *bonds* and a payment to the treasury, or bank, with the commitment to repay the sums at the end of the war, as an event that gives rise to exceptional expenditure (these are the cases of the *forced* or “*iron*” *savings*).

As can be seen, the arguments that are widely presented relate to discussions regarding *technique* or the operation of the *circuit* of capital, not to the “logic of the system”, which derives its irreproachability or rationality from experience and obvious doctrines.

This view of mine, reconfirmed in the lessons of 1944, has found Borgatta’s support, in the most exhaustive work produced up to now on the finance of war (*op. cit.* of 1945).

He also differentiates between the negation of the impossibility of the *logic* of the complete closure of the “circuit”, from a theoretical point of view, and the “practical causes of the failure of the circuit” (pp. 606-612). Among these he also placed the cost of price policy, the distribution of new purchasing power among numerous and difficult to control classes, expenditure and indemnities in favour of foreign States, etc.

Borgatta found a single point of contention in the function that incidentally I assigned to *credit* in the financing of extraordinary expenditure. He did not consider it to be admissible among the procedures for finance thus qualified, because credit can have a temporary function, as it permits the anticipation of future earnings. “Either credit is reimbursed before the end of the war, and the means of the reimbursement must be drawn from an increase in the income produced or by a compression of private consumption, or it is reimbursed after the war, and then it is resolved in the anticipated consumption of future incomes” (*op. cit.*, p. 147).

Who has read my work will notice the similarity also in the expression of opinions: indeed I wrote, in the spirit of the Keynesian vision, that the ceased hoarding and the concession of bank credit do not represent an alternative to the formation of saving, but the necessary preparation to the increase in savings. “If I mention (the recourse to credit) it is to underline the *temporary* function that must be assigned to credit so as to avoid inflation, which is the negative aspect that it is intended to avoid in the procedures of war financing with the system of the circuit of capital.”

If the rate of increase of savings is equal to that of the needs of investments in relation to the growth and fulfilment of needs, respectively normal and extraordinary ones in private and public life, then the intermediary function temporarily assigned to credit would not be necessary. However, this must discount (anticipating the amount within certain limits) the flows of future savings, in the cases in which demand for capital is higher, even if it is so temporarily, than the supply that can be represented only by the savings already made. “Therefore, in practice, alongside the investment of current savings, that is to say, drawn from current income, and to the consumption of pre-existing capital of assets already accumulated (which are often not maintained and for which provisions for amortization are not made during wartime), there is a *third* means to provide for the discontinuous needs of investments: that is to say, the discount of the formation of future savings, as margins of future incomes.” (It is intended for periods of time that are within the context of the same cycle in which the problem is economically solved, even with the technique of credit.) There does not appear to be a divergence of points of view between the propositions of the illustrious academic and my previous ones, if the opposite propositions and others that I have rationally expressed in my quoted essay of 1940 are compared³⁰³.

³⁰³ In a reasoned expression of these problems by V. Marrama (*Di un’alternativa all’inflazione nella economia di guerra [About an alternative to inflation in the economy of war]*, Edizioni Italiane, 1947, pp. 53-

THE END.

54), after writing that “d’Albergo gave an excellent contribution to the study of the complex question of future savings”, that “justifiably observes that the recourse to credit must be temporary” and after having reported expressions of my argument on this subject, he adds to my opinion the comfort of similar ideas expressed later by Cabiati (*op. cit.* of 1947) and C. Arena (*L’economia di guerra [War economy]*, in *Quaderni di cultura politica [Notebooks of political culture]*, 1941).

ERNESTO D'ALBERGO, ECONOMY OF PUBLIC FINANCE
Digital Edition by Nino Luciani, Alm @ DL, Bologna 2014

Ernesto d'Albergo – Bibliography*

1929	1) <i>Il contributo di miglioria e le imposte speciali [The betterment tax and special taxes]</i> , in “Studio Editoriale Moderno” [Modern Editorial Study], s.l.
	2) <i>Le rivalutazioni patrimoniali e l'imposta di ricchezza mobile [Assets re-evaluation and the tax on mobile wealth]</i> , in “Rivista di Politica Economica” [Political economy journal], Rome.
	3) <i>L'imposta personale [Personal tax]</i> , Milan Locatelli & Sommaruga, s.l.
	4) <i>Le ultime vicende della politica monetaria degli Stati Uniti [Recent developments in monetary policy of the United States]</i> , in “Rivista di Politica Economica” [Political economy journal], Rome.
	5) <i>Aspetti e tendenze della nuova politica economica dell'Italia [Characteristics and trends of new Italian economic policy]</i> , in Studio Editoriale Moderno [Modern Editorial Study], Catania.
1930	6) <i>Considerazioni sulla riforma della finanza locale in Italia [Observations about local finance reform in Italy]</i> , in “Rivista Internazionale di Scienze Sociali e Discipline Ausiliarie” [International journal of social sciences and associated disciplines], Milan, s.l.
1931	7) <i>I limiti di convenienza dei prestiti esteri [Convenience limitations of foreign loans]</i> , in “Giornale degli economisti e annali di economia” [Economist journal and economy annals], Cedam, Padua.
	8) <i>La crisi dell'imposta personale sul reddito [The crisis of the personal tax on income]</i> , Cedam, Padua.
	19) <i>Nuovi orientamenti della finanza pubblica inglese (Verso il tramonto del self-government?) [New trends in English public finance (Towards the decline of self-government ?)]</i> , in “Rivista di Politica Economica” [Political economy journal], Rome.
	10) <i>Osservazioni critiche intorno alle “imposte sugli scambi” [Critical observations on “taxes on exchanges”]</i> , in “Giornale degli economisti e annali di economia” [Economist journal and economy annals], Cedam, Padua.
	11) <i>Del principio “produttivistico” nei sistemi di imposizione personale del reddito [The “productivistic” principle in personal income tax systems]</i> , in “Giornale degli economisti e annali di economia” [Economist journal and economy annals], Cedam, Padova.
1932	12) <i>Intorno al concetto di costo dell'attività finanziaria [About the concept of the cost of financial activity]</i> , in “Annali di Economia dell'Università Bocconi” [Bocconi University Economy Annals], Milan.
	13) <i>Reddito e imposte. Saggio critico sul produttivismo nell'attività finanziaria [Income and taxation. Critical essay on productivism in financial activity]</i> , in “Rivista Internazionale di Scienze sociali” [International journal of social sciences], July, Milan.
	14) <i>I limiti di convenienza nei prestiti esteri [Convenience limitations of foreign loans]</i> , in “Rivista di Statistica” [Statistics journal], s.l.
	15) <i>I presupposti dello Stato Corporativo e il fondamento dell'imposizione [Prerequisites of the Corporate State and the basis of taxation]</i> , in Atti del II Convegno di Studi Sindacali e Corporativi [Proceedings of the II Conference on Union and Corporate Studies], Ferrara.
1933 /34	16) <i>Nuovi studi sull'ammortamento del debito pubblico [New studies on the amortization of public debt]</i> , in “Giornale degli economisti e annali di economia” [Economist journal and economy annals], Cedam, Padua.
	17) <i>Della sensibilità delle imposte in rapporto alle fluttuazioni economiche [About the sensitivity of taxes to economic fluctuations]</i> , in “Riforma sociale” [Social Reform], Turin.
	18) <i>Sulla recente riforma dell'imposta complementare sul reddito [About the recent reform of the complementary income tax]</i> , in “Il Giornale Economico” [Economy journal], s.l.
	119) <i>Della bilancia dei pagamenti [About the Balance of international payments]</i> , in “Giornale degli economisti e annali di economia” [Economist journal and economy annals], Cedam, Padua.
1935	20) <i>Sulla neutralizzazione della sensibilità congiunturale delle imposte [About the neutralization of economic sensitivity of taxes]</i> , in “Rivista Internazionale di Scienze Sociali” [International journal of social sciences], Milan.
	21) <i>La condensazione delle aliquote dell'imposta sugli scambi in recenti riforme legislative [The condensation of rates of the tax on exchanges in recent legislative reforms]</i> , in “Giornale degli economisti e annali di economia” [Economist journal and economy annals], Cedam, Padova.
	22) <i>Aspetti statistici della finanza corporativa [Statistical aspects of corporate finance]</i> , in “Barometro Economico Italiano” [Italian Economic Barometer], Rome.
	23) <i>Politica tributaria hitleriana e teoria degli “sgravi fiscali” [Hitlerian tributary policy and the theory of tax</i>

ERNESTO D'ALBERGO, ECONOMY OF PUBLIC FINANCE
Digital Edition by Nino Luciani, Alm @ DL, Bologna 2014

1936	<i>reliefs</i> in “Rivista Internazionale di Scienze Sociali” [International journal of social sciences], Milan.
	24) <i>Sul metodo nello studio della finanza pubblica</i> [On methodology in the study of public finance], in “Rivista Internazionale di Scienze sociali” [International journal of social sciences], Milan.
	25) <i>La funzione della banca e gli effetti economici dell'imposizione</i> , [The bank function and the economic effects of imposition], in “Rivista Bancaria” [Banking Review], Minerva Bancaria, Milan.
	26) <i>Di alcuni rapporti fra Banca Privata e Stato</i> [About some of the relationships between Private Bank and State], in “Rivista italiana di Scienze Economiche” [Italian journal of economic sciences], Bologna.
	27) <i>Guerra e movimento produttivo</i> [War and productive cultural movement], in “Raccolta di Studi economici finanziari corporativi” [Collection of economic corporate studies], Rome.
1937	28) <i>La determinazione della risultante del Barone e i dati del problema finanziario</i> [The determination of Barone's resultant and data of the financial problem], Annali dell'Univ. di Ferrara [Annals of the University of Ferrara], Ferrara.
	219) <i>A proposito di “diffusione” dell'imposta</i> [About the “diffusion” of taxes], in Rivista di diritto finanziario e scienza delle finanze [Journal of financial law and the science of finance], Giuffrè, Milan.
	30) <i>Discriminazione delle spese pubbliche indivisibili ed elisione delle rendite di protezione</i> [Differentiation of indivisible public expenditure and elision of protection revenues], in “Rivista di studi senesi” [Siena studies review], 11936, and in “Studi in onore di F. Flora” [Studies in honour of F. Flora], Zanichelli, Bologna, p. 134.
	31) <i>L'economia italiana nel 11936 - VII – Finanza Statale</i> [Italian economy in 11936 - VII - State Finance] in “Rivista Internazionale di Scienze sociali [International Journal of Social Sciences]”, Milan.
	32) <i>Problemi della finanza italiana</i> [Italian finance problems], Cedam, Padua.
	33) <i>Politica del credito e congiuntura</i> [Credit and economy policy], in “Rassegna Monetaria” [Monetary review], s.l.
1938	34) <i>L'autarchia e il problema della valuta</i> [Autarchy and the problem of currency] in “Giornale degli economisti e annali di economia” [Economist journal and economy annals], Cedam, Padua.
	35) <i>Sul carattere di tributo reale dell'imposta straordinaria immobiliare</i> [On the character of real tribute of the extraordinary real estate tax], Cedam, Padua.
	36) <i>L'economia italiana nel 1937 - VII - Finanza Pubblica</i> [Italian economy in 11936 - VII - Public finance] in “Rivista Internazionale di Scienze sociali [International Journal of Social Sciences]”, Milan.
	37) <i>Il principio del reddito distribuito come imponibile nel nuovo sistema finanziario italiano</i> [The principle of distributed income as taxable income in the new Italian financial system], in “Rivista Bancaria” [Banking Review], Minerva Bancaria, Milan.
	38) <i>Sul carattere di tributo reale dell'imposta straordinaria immobiliare</i> [On the character of real tribute of the extraordinary real estate tax], Cedam, Padua.
	319) <i>Redditi (denuncia obbligatoria dei) - Redditi superiori a Lire 10.000 (Imposta sui)</i> [Income (compulsory declaration) – (Taxes on) Incomes over 10,000 liras], in “Nuovo Digesto Italiano” [New Italian Digest], Turin.
1939	40) <i>Il problema finanziario e le nuove teorie economiche</i> [The financial problem and new economic theories], in “Giornale degli economisti e annali di economia” [Economist journal and economy annals], Cedam, Padua.
	41) <i>La politica finanziaria dei grandi Stati dal dopoguerra ad oggi</i> [Financial policy in large States from the post-war period up to now], I.S.P.I., Milan.
	42) <i>Principi di scienza delle finanze</i> [Principles of science of finance], “Appunti per gli studenti” [Notes for students], Giuffrè, Milan, p. 364.
	43) <i>Il nuovo “piano” finanziario tedesco</i> [The new German “financial plan”], in “Rivista Bancaria” [Banking Review], Minerva Bancaria, Milan.
1940	44) <i>Les banques italiennes</i> [Italian banks], in “Enquêtes sur les changements de structure du crédit et de la banque” [Survey on the changes in structure of credit and of banks], 11918–11938, Paris, Recueil Sirey.
	45) <i>Aspetti della recente riforma fiscale</i> [Aspects of the recent fiscal reform], in “Giornale degli Economisti e Annali di Economia” [Economist Journal and Economy Annals], Cedam, Padua.
	46) <i>Tasse sulle società commerciali</i> [Taxes on commercial enterprises], in “Nuovo Digesto Italiano” [New Italian Digest], Turin.
	47) <i>Sovraimposte</i> [Surplus taxes], in “Nuovo Digesto Italiano” [New Italian Digest], Turin.
	48) <i>Finanza pubblica</i> [Public finance] in “Rivista Internazionale di Scienze sociali [International Journal of Social Sciences]”, Milan.
	419) <i>La situazione economica internazionale</i> [International economic situation], Cedam, Padua.

ERNESTO D'ALBERGO, ECONOMY OF PUBLIC FINANCE
Digital Edition by Nino Luciani, Alm @ DL, Bologna 2014

1941	50) <i>Politica finanziaria, reddito e risparmio nell'economia dal dopoguerra ad oggi [Financial policy, income and savings in the economy from the post-war period up to now]</i> , in "Notiziario Economico" [Economy news], Cariplo, Milan.
	51) <i>Politica finanziaria, reddito e risparmio nell'economia dal dopoguerra [Financial policy, income and savings in the economy of the post-war period]</i> , in "Notiziario Economico" [Economy news], Cariplo, Milan.
	52) <i>Il rischio dell'impresa e l'ordinamento corporativo [Enterprise risk and corporate organization]</i> , in "Rivista Bancaria delle Assicurazioni e dei Servizi Tributari" [Banking review of insurance and taxation services], Milan.
1942	53) <i>Problemi tributari e assicurativi. Alcune relazioni fra politica finanziaria, reddito e risparmio [Taxation and insurance issues. Some of the relationships between financial policy, income and savings]</i> A. Giuffrè, Milan, p. 262.
	54) <i>Sulla misurazione degli effetti economici delle imposte [About the measurement of economic effects of taxes]</i> , in "Giornale degli Economisti e Annali di Economia" [Economist Journal and Economy Annals], Cedam, Padua.
	55) <i>Il rischio dell'impresa e l'ordinamento corporativo [Enterprise risk and corporate organization]</i> , in "Rivista Bancaria delle Assicurazioni e dei Servizi Tributari" [Banking review of insurance and taxation services], Milan.
	56) <i>Il problema monetario nel dopoguerra [The monetary problem in the post-war period]</i> , Arti Grafiche Pacini Mariotti, Pisa.
	57) <i>Riforme e rilievi in tema di tassazione degli utili di guerra [Reforms and observations on the issue of taxation of war profits]</i> , in "Rivista Bancaria delle Assicurazioni e dei Servizi Tributari" [Banking review of insurance and taxation services], Milan.
	58) <i>L'agricoltura e gli utili di congiuntura bellica soggetti a tassazione [Agriculture and profits from the war economic situation subject to taxation]</i> , in "Rivista Bancaria delle Assicurazioni e dei Servizi Tributari" [Banking review of insurance and taxation services], Milan.
	519) <i>Il fattore finanziario e l'impiego del potenziale di lavoro [The financial factor and the employment of work potential]</i> , in "Rivista Bancaria delle Assicurazioni e dei Servizi Tributari" [Banking review of insurance and taxation services], Milan.
	60) <i>Alcune relazioni fra politica finanziaria, reddito e risparmio [Some of the relationships between financial policy, income and savings]</i> , in "Atti della VIII Riunione Scientifica" of della Società Italiana di Demografia e Statistica" [Proceedings of the 8th Scientific Meeting of the Italian Demography and Statistics Society] s.l.
	61) <i>Scienza delle Finanze. Cenni teorici sulla finanza ordinaria e straordinaria ad uso degli studenti [Science of finance. Theoretical notes on ordinary and extraordinary finance for students]</i> , Ed. Universitarie, Bologna, p. 448.
1943	62) <i>Sviluppi di un teorema finanziario e sue relazioni con il massimo benessere [Developments of a financial theory and its relationships with maximum welfare]</i> , in "Studi in memoria di Guglielmo Masci" [Studies in memory of Guglielmo Masci], Giuffrè, Milan, p. 382.
	63) <i>Il nuovo regime fiscale dei redditi fondiari [The new fiscal regime for land revenues]</i> , in "Rivista Bancaria delle Assicurazioni e dei Servizi Tributari" [Banking review of insurance and taxation services], Milan.
1944	64) <i>Scienza delle Finanze ad uso degli studenti [Science of finance for students]</i> , 2nd edition, UPEB, Bologna, p. 6319.
	65) <i>Moneta, Credito e Risparmio per il finanziamento della ricostruzione [Money, credit and savings for the financing of reconstruction]</i> , in "Rivista Bancaria" [Banking Review], Minerva Bancaria, Milan.
1945	66) <i>Prestiti e Imposte nelle nuove teorie e nella esperienza bellica [Loans and taxes in new theories and in the war experience]</i> , in "Studi dell'Istituto di scienze economiche e statistiche" [Studies of the Institute of economic and statistical sciences of Milan University], Milan, p. 256.
	67) <i>Esperimenti di stabilizzazione monetari [Experiments in monetary stabilisation]</i> , in "Il problema monetario italiano" [The Italian monetary problem] s.l.
1947	68) <i>Tutela del risparmio e controllo del credito nella costituzione italiana [Protection of savings and credit control in the Italian Constitution]</i> , in "Rivista del Commercio" [Commercial Review], Rome.
	619) <i>Manovra del credito e stabilizzazione monetaria [Credit management and monetary stabilization]</i> , in "Rivista del Commercio" [Commercial Review], Rome.
	70) <i>Misure urgenti e "riforme" tributarie [Urgent measures and taxation "reforms"]</i> , in "Rivista Bancaria" [Banking Review], Minerva Bancaria, Milan.
	71) <i>Problemi dell'emigrazione italiana [Problems of Italian emigration]</i> , Zuffi Editore, Bologna.
	72) <i>Effetti delle imposte e teorie del full employment [Effects of taxes and theories of full employment]</i> , in

ERNESTO D'ALBERGO, ECONOMY OF PUBLIC FINANCE
Digital Edition by Nino Luciani, Alm @ DL, Bologna 2014

1948	“Economia Internazionale” [International Economy], Genoa.
	73) <i>Restaurazione economica e “segreto bancario”</i> [Economic restoration and “banking secrecy”], in “Rivista Bancaria” [Banking Review], Minerva Bancaria, Milan.
1949	74) <i>L'analisi Pareto-Slutsky della domanda e la teoria delle imposte sui consumi</i> [The Pareto-Slutsky analysis of demand and the theory of taxes on consumptions], in “Vilfredo Pareto l'economista e il sociologo” [Vilfredo Pareto, economist and sociologist], Casa Editrice Rodolfo Malfassi, Milan, and in “Giornale degli Economisti e annali di economia” [Economist journal and economy annals], Cedam, Padua.
	75) <i>Proporzionalità e progressività dei tributi nelle carte costituzionali italiane</i> [Proportionality and progressivity of tributes in Italian constitutional charters], in “Annali dell'Università di Palermo” [Annals of the Faculty of economy and commerce of the University of Palermo], Faculty of Economy and Commerce, Palermo.
	76) <i>Benessere materiale e morale sociale</i> [Material and moral social welfare], in “Rivista Idea” [Ideas Review], s.l.
	77) <i>Orientamenti per una revisione del sistema tributario italiano</i> [Orientations for a revision of the Italian taxation system] STEB, Bologna.
	78) <i>L'opera e il pensiero di Renzo Fubini</i> [The work and thought of Renzo Fubini], in “Rivista di Diritto Finanziario e Scienza delle Finanze” [Journal of financial law and the science of finance], Giuffrè, Milan.
	719) <i>Aspectos de la politica fiscal de Italia después de la guerra</i> [Aspects of fiscal policy in Italy in the post-war period], in “Revista de la situación económica en Italia” [Review of the Economic Conditions in Italy], Rome.
1950	80) <i>Di una introduzione allo studio teorico della economia finanziaria</i> [About the introduction of a theoretical study in financial economy], in “Rivista di Diritto Finanziario e Scienza delle Finanze” [Review of financial law and the science of finance], Giuffrè, Milan.
	81) <i>Il fattore fiscale e le unioni economiche</i> [The fiscal factor and economic unions], in “Rivista di Politica Economic” [Political economy journal], Rome.
	82) <i>Gino Borgatta</i> , in “Rivista Bancaria” [Banking Review], Minerva Bancaria, Milan.
	83) <i>Beitrag zur finanzwissenschaft und zur geldtheorie - Festschrift für Rudolf Stucken</i> , Vandenhoeck & Ruprecht, Göttingen.
	84) <i>Le stanze di compensazione in Italia. I prorogati pagamenti</i> [Clearing houses in Italy. Deferred payments], in “Rivista Bancaria” [Banking Review], Minerva Bancaria, Milan.
	85) <i>Mauro Fasiani</i> , in “Rivista Bancaria” [Banking Review], Minerva Bancaria, Milan.
	86) <i>Rilievi sui progetti di “Riforma Tributaria” in discussione in Italia</i> [Observations on projects of “Tax reform debated in Italy”], in “Studi Economici” [Economy Studies], Naples.
1951	87) <i>Economia della finanza pubblica, (Corso di lezioni di scienza delle finanze)</i> [Public finance economy. (A course of lessons in the science of finance)], STEB, Bologna.
	88) <i>Les problèmes de l'économie financière traditionnelle et la théorie keynesienne</i> [The problems of traditional financial economy and Keynesian theory], Conference at the Faculty of Law of Paris, in “Revue de science et de législation financières” [Financial science and legislation review], Paris.
	819) <i>Theoretische darstellungsmethoden des problemes det unterschiedlichen erfabbarkeit der steuerobjekte bei direkter besteuierung</i> , in “Festschrift für Rudolf Stucken”, s.l.
	190) <i>Sur la double taxation de l'épargne</i> [About the double taxation of savings], in “Revue de Science et de Législation Financières” [Science and Financial Law Review], Paris.
	191) <i>L'hétérogénéité logique de la taxation du revenu consommé et du revenu produit</i> [Logical heterogeneity of taxation of revenue consumed and revenue produced], in “Revue de Science et de Législation Financières” [Science and Financial Law Review], Paris.
1952	192) <i>Di una proprietà dell'imposta progressiva alla luce della “matematica fiscale” e della economia finanziaria</i> [About a property of the progressive tax in light of “fiscal mathematics” and of financial economy], in “Giornale degli economisti e annali di economia” [Economist journal and economy annals], Cedam, Padua.
	193) <i>Economia della finanza pubblica, (Corso di lezioni di scienza delle finanze)</i> [Public finance economy. (A course of lessons in the science of finance)], STEB, Bologna.
	194) <i>Sul progetto di legge per la finanza locale</i> [About the project of local finance law], in “Camera di Commercio Industria e Agricoltura di Milano” [Milan Chamber of Commerce, Industry and Agriculture], Milan.
	195) <i>Genesi e tassazione di alcuni consumi voluttuari</i> [Genesis and taxation of some luxury goods], in the journal “Lo Spettacolo” [Show Business], s.l.
	196) <i>Legislazione tributaria e produttività</i> [Taxation law and productivity], in “Produttività” [Productivity], s.l.

ERNESTO D'ALBERGO, ECONOMY OF PUBLIC FINANCE
Digital Edition by Nino Luciani, Alm @ DL, Bologna 2014

1953	
	197) <i>Homogeneidad secular de las premisas de la cooperacion financiera internacional [Secular homogeneity of the premises of international financial cooperation]</i> , in “Revista de la situacion economica en Italia” [Review of the Economic Conditions in Italy], Rome.
	198) <i>Sameness of the premises of international financial cooperation throughout time</i> , in “Review of the Economic Conditions in Italy”, Rome.
	1919) <i>Il problema della regolarità dell'occupazione. La disoccupazione ciclica e la sua Prevenzione [The problem of regularity of employment. Cyclic unemployment and its prevention]</i> , in “Atti della Commissione Parlamentare d'inchiesta sulla disoccupazione” [Proceedings of the Parliamentary Committee of inquiry on unemployment], Rome.
	100) <i>Gino Borgatta</i> , in “Studi in onore di Gino Borgatta” [Studies in honour of Gino Borgatta], Vol. II, Istituto di cultura bancaria [Institute of banking culture], Milan, p. 363.
	101) <i>Contrapposizione razionale degli schemi per lo studio degli effetti economici delle imposte [Rational comparison of models for the study of the economic effects of taxes]</i> , in “Studi in onore di Gino Borgatta” [Studies in honour of Gino Borgatta], Vol. II, Istituto di cultura bancaria [Institute of banking culture], Milan, p. 338.
1954	102) <i>Di una proprietà dell'imposta progressiva alla luce della matematica finanziaria e dell'economia finanziaria [About a property of the progressive tax in the light of “fiscal mathematics” and of financial economy]</i> , Cedam, Padova, pp. 4819.
	103) <i>“Vecchia” teoria finanziaria e “nuove” incomprensioni [“Old” financial theory and “new” misunderstandings]</i> , in Rivista di diritto finanziario e scienza delle finanze [Journal of financial law and the science of finance], Giuffrè, Milan.
	<i>Un aspetto della differenziazione tra economia e diritto [An aspect of the differentiation between economy and law]</i> , in “Studi Senesi” [Siena Studies], in memoria di O. Vannini, 1954–1955, Siena.
	104) <i>Alcuni rilievi critici intorno all'imposta sulle società [Some observations on the tax on companies]</i> , in “Rivista Bancaria” [Banking Review], Minerva Bancaria, Milan.
	106) <i>Rettifiche di opinioni in tema di esenzioni e contributi [Adjustments in opinions with regard to exemptions and contributions]</i> , in “Rivista Bancaria” [Banking Review], Minerva Bancaria, Milan.
1955	107) <i>Brevi note sull'ammortamento e sui “limiti” del debito pubblico [Brief notes on the amortization and on the “limits” of public debt]</i> , in “Studi in onore di Luigi Nina” [Studies in honour of Luigi Nina], s.l.
	108) <i>Politica doganale e sviluppo economico [Customs policy and economic development]</i> , in “Rassegna di Diritto e Tecnica Doganale e delle Imposte di Fabbricazione” [Review of law, customs methodology and manufacturing taxes], Rome.
	1019) <i>L'applicazione al settore aziendale della legge per il risarcimento dei danni di guerra [The application of the law for the compensation of war damages to business]</i> , in “Rassegna Giuridica ed Economica sui danni di guerra” [Juridical and economic review on war damages], Rome.
	110) <i>Leggi “giuste” e nostra struttura economica [“Just” laws and our economic structure]</i> , in “La proprietà Edilizia Lombarda” [Real estate in Lombardy], s.l.
	111) <i>Appunti Economia Bancaria [Notes on banking economy]</i> , in C.I.D.A., Istituto Superiore per la Direzione Aziendale [Higher Institute for Business Management], s.l.
1956	112) <i>Sulla tutela dell'avviamento commerciale [About the protection of commercial start-ups]</i> , Industria Tipografica Imperia, Rome, p. 150.
	113) <i>Messaggio e visita alla Scuola di Losanna [Message and visit to the Lausanne School]</i> , in “Rivista Bancaria” [Banking Review], Minerva Bancaria, Milan.
	114) <i>Economia della finanza pubblica ed economia bancaria nell'ordinamento degli studi [Public finance economy and banking economy in the organisation of studies]</i> , in “Rivista Bancaria” [Banking Review], Minerva Bancaria, Milan.
1957	115) <i>Visioni teoriche e impressioni politiche nella “manovra” di una imposta di fabbricazione [Theoretical visions and political impressions of the “management” of a manufacturing tax]</i> , in “Rassegna di Diritto e Tecnica Doganale e delle Imposte di Fabbricazione” [Review of law, customs methodology and manufacturing taxes], Rome.
	116) <i>Sull'indirizzo scientifico di Benvenuto Griziotti [About Benvenuto Griziotti's scientific approach]</i> , in “Giornale degli economisti e annali di economia” [Economist journal and economy annals], Cedam, Padua.

ERNESTO D'ALBERGO, ECONOMY OF PUBLIC FINANCE
Digital Edition by Nino Luciani, Alm @ DL, Bologna 2014

	117) <i>L'economia italiana nel 11956 [Italian economy in 11956]</i> , in the journal "Economia e Storia" [Economy and history], s.l.
	118) <i>Una politica di libertà economica per il progresso sociale [A policy of economic freedom for social progress]</i> , Conference held in Florence by the Committee for International Harmony, s.l.
	1119) <i>Remarks on Italy's public debt policy</i> , in "Review of the Economic Conditions in Italy", Rome.
	120) <i>Observaciones sobre la politica italiana de deuda publica [Observations on Italian policy on public debt]</i> , in "Revista de la situacion economica en Italia" [Review of the Economic Conditions in Italy], Rome.
	121) <i>Il controllo ortodosso del credito nelle condizioni postbelliche [Orthodox credit control in post-war conditions]</i> , in "Rivista Bancaria" [Banking Review], Minerva Bancaria, Milan.
1958	122) <i>Una visione prekeynesiana della 'fiscal policy' [A pre-Keynesian view of fiscal policy]</i> , in "Studi Economici" [Economy Studies], Naples.
	123) <i>Schemi di Pantaleoni e visioni odierne in tema di effetti economici delle imposte [Pantaleoni's models and views on the economic effects of taxes]</i> , in "Giornale degli Economisti e Annali di Economia" [Economist Journal and Economy Annals], Cedam, Padua.
	124) <i>Teoria dello "scambio volontario" e dell'utilità collettiva [Theory of "voluntary exchange" and collective utility]</i> , in "Stato Sociale" [Social State], Turin.
	125) <i>Finanze e tributi: osservazioni sull'aspetto fiscale del mercato comune [Finance and tributes: observations on the fiscal aspects of the common market]</i> , in "Comunità Economica Europea" [European Economic Community], s.l.
	126) <i>Il regime fiscale delle operazioni di borsa [The fiscal regime of stock exchange operations]</i> , Giuffrè, Milan.
	127) <i>In tema di "neutralità" della scienza e di "idee-guida" [On "neutrality" of science and of "guiding ideas"]</i> , s.l.
1959	128) <i>Premesse scientifiche generali e teoria dell'illusione finanziaria [General scientific premises and the theory of financial illusion]</i> , in "Economia Internazionale" [International Economy], Genoa.
	1219) <i>Incontri sui problemi della legislazione [Meetings on the problems of legislation]</i> , in "Rassegna Parlamentare" [Parliamentary Review], Giuffrè, Milan.
	130) <i>Inattualità e fallacia delle imposizioni sulle aree e sull'incremento di valore degli immobili [Obsolescence and fallacy of impositions on the category of immoveable assets and on their increase in value]</i> , in "La proprietà edilizia lombarda" [Lombardy real estate], s.l.
	131) <i>Appunti sulla finanza pubblica produttivistica in rapporto allo sviluppo economico [Notes on productivistic public finance in relation to economic development]</i> , Scuola di Sviluppo Economico, Unione Italiana delle Camere di Commercio, Industria e Agricoltura [School of Economic Development, Italian Union of Chambers of Commerce, Industry and Agriculture], Rome.
1960	132) <i>Economia bancaria [Banking economy]</i> , "Centro di studi aziendali" [Centre for business studies], Naples.
	133) <i>Considerazioni finali sul sistema tributario nei sei Paesi del M.E.C. [Conclusive considerations on taxation systems in the six countries of the European Common Market]</i> , in "Atti del Convegno degli esperti fiscali dei Paesi del M.E.C." [Proceedings of the Conference of fiscal experts of the countries of the European Common Market], Giuffrè, Milan.
	134) <i>Sui limiti di discrezionalità del sistema bancario nella creazione di moneta creditizia [On the limits of discretion of the banking system in the creation of credit money]</i> , in "Rivista Bancaria" [Banking Review], Minerva Bancaria, Milan.
	135) <i>Sull'interpretazione delle norme fiscali del trattato istitutivo del Mercato Comune [About the interpretation of fiscal regulations in the EC Treaty]</i> , in "Rivista Bancaria" [Banking Review], Minerva Bancaria, Milan.
	136) <i>Il bilancio statale nella teoria e nella realtà [State budget in theory and in practice]</i> , in "Rivista Bancaria" [Banking Review], Minerva Bancaria, Milan.
1961	137) <i>Paradossi sul ruolo del fattore fiscale nella determinazione del "reddito d'impresa" [Paradoxes on the role of the fiscal factor in the determination of "enterprise income"]</i> , in "Saggi di economia aziendale e sociale, in onore di G. Zappa" [Essays of business and social economy, in honour of G. Zappa], Vol. I, Milan, p. 680.
	138) <i>Rilievi critici sull'ordinamento dell'imposta generale sull'entrata [Critical observations on the organization of the general tax on income]</i> , in "Convegno di Studi di Politica Economica e Finanziaria" [Conference of Economic and Financial Policy Studies], Turin.
	1319) <i>Per una nuova disciplina delle società per azioni e delle attività di borsa [For a new discipline for public</i>

ERNESTO D'ALBERGO, ECONOMY OF PUBLIC FINANCE
Digital Edition by Nino Luciani, Alm @ DL, Bologna 2014

	<i>limited companies and stock exchange activity</i>], in “Rassegna Parlamentare” [Parliamentary Review], Giuffrè, Milan.
1962	140) <i>Elementi volontaristici e coattivi nei rapporti finanziari con gli Enti pubblici [Voluntary and compulsive elements in financial relations with public bodies]</i> , in “Stato Sociale” [Social State], Turin.
	141) <i>I principi direttivi per la riforma della pubblica amministrazione [Directive principles for the reform of public administration]</i> , in “Rassegna Parlamentare” [Parliamentary Review], Giuffrè, Milan.
	142) <i>In tema di applicazione dell'imposta sulle anticipazioni e della surrogata imposta di registro [On the application of taxes on advances and on the surrogate registration tax]</i> , in “Diritto e pratica tributaria” [Fiscal law and practice], Cedam, Padua.
1963	143) <i>Per il progresso degli studi finanziari [For the progress of financial studies]</i> , in “Rivista Bancaria” [Banking Review], Minerva Bancaria, Milan.
	144) <i>Finanza pubblica e benessere [Public finance and welfare]</i> in “Giornale degli economisti e annali di economia” [Economist journal and economy annals], Cedam, Padua.
1964	145) <i>Problemi economici della legislazione urbanistica [Economic problems of town planning legislation]</i> , Giuffrè, Milan, p. 453.
1965	146) <i>In tema di “svolte” nella teoria della finanza pubblica [“Turning points” in the theory of public finance]</i> , in “Studi in onore di G. Zingali” [Studies in honour of G. Zingali], Economia Finanza e Statistica [Economy, Finance and Statistics], Vol. I, A. XX Giuffrè, Milan, p. 672, and in “Economia Internazionale” [International Economy], 11967, Geneva.
	147) <i>Psychologie sociale, finances publiques et économie du bien-etre [Social psychology, public finances and welfare economy]</i> , in “Finanzarchiv”, Mohr, Tubingen.
	148) <i>Pieno impiego, inflazione e fiscal policy [Full employment, inflation and fiscal policy]</i> in “Rivista Bancaria” [Banking Review], Minerva Bancaria, Milan.
	149) <i>Brevi note sull'ideale di giustizia nella scienza delle finanze [Brief notes on the ideal of justice in the science of finance]</i> , in “Studi in memoria di Carmelo Sgroi (18193-11952)” [Studies in memory of Carmelo Sgroi (18193-11952)], s.l.
1966	150) <i>Gli effetti di imposte e spese del bilancio in regime collettivistico [The effects of taxes and budget expenditure in a collectivistic system]</i> , in “Studi in onore di Marco Fanno” [Studies in honour of Marco Fanno], Vol. I, Cedam, Padua, p. 5196, e in “Giornale degli economisti e Annali di Economia” [Economist journal and economy annals], Cedam, Padua.
1967	151) <i>Considerazioni sulla riforma tributaria [Considerations on fiscal reform]</i> , in “Confedilizia” [Confederazione Italiana Proprietà Edilizia – Italian Real Estate Confederation], Rome.
	152) <i>La tassazione delle plusvalenze patrimoniali [The taxation of surplus values on assets]</i> , in “Associazione nazionale tributaristi italiani; Atti del IX congresso nazionale” [National Association of Italian Tax Consultants; Proceedings of the 19th National Conference], Cedam, Padua.
	153) <i>Sulla logica dei sistemi tributari vigenti o possibili [On the logic of current or possible tax systems]</i> , in “Nel corso di lezioni universitarie” [In the course of university lessons], Bulzoni, Rome, 11967-68.
	154) <i>Sommario di Economia Bancaria [Banking Economy Summary]</i> , in “C.I.D.A., Istituto Superiore per la Direzione Aziendale” [C.I.D.A. - Higher Institute for Business Management], s.l.
1968	155) <i>Il fondamento logico dell'imposta sugli introiti lordi [The logical basis of the tax on gross revenues]</i> , in “Studi sull'imposta sulle vendite” [Studies on the tax on sales], Facoltà di Giurisprudenza [Faculty of Jurisprudence], Giuffrè, and in “Saggi in onore del Centenario della Ragioneria Generale dello Stato” [Essays in honour of the Centenary of the State General Accounting Office], 119619.
	156) <i>Un'identificazione di schemi per l'economia finanziaria [Identification of models for financial economy]</i> , in “Giornale degli economisti e annali di economia” [Economist journal and economy annals], Cedam, Padua.
1969	157) <i>Necrologia [Necrology]</i> , in “Rivista Bancaria” [Banking Review], Minerva Bancaria, Milan.
	158) <i>Aspetti del regime tributario dei titoli obbligazionari pubblici [Aspects of fiscal treatment of public bonds]</i> , in “Rivista Bancaria” [Banking Review], Minerva Bancaria, Milan.
	1519) <i>Potere statale “e” regionale nella politica di piano? [State “and” regional power in planning policy?]</i> , in “La pianificazione regionale: problemi e teoria di metodo nelle esperienze italiana e straniera” [Regional planning: problems and method theory in the Italian experience and abroad], Atti del Convegno Internazionale di Sorrento 12–14 sett. [Proceedings of the International Conference in Sorrento 12–14 September] 11968, Marsilio,

ERNESTO D'ALBERGO, ECONOMY OF PUBLIC FINANCE
Digital Edition by Nino Luciani, Alm @ DL, Bologna 2014

	Padua, p. 275.
1970	160) <i>Sulle classificazioni tributarie nei rapporti internazionali [On fiscal classifications in international relations]</i> , in “Rivista Bancaria” [Banking Review], Minerva Bancaria, Milan.
	161) <i>Sulla riforma tributaria [On fiscal reform]</i> , in “Rassegna Parlamentare” [Parliamentary Review], Giuffrè, Milan.
	162) <i>Genesi convergenti del calcolo finanziario pubblico [Converging genesis of public finance calculations]</i> , in “Giornale degli economisti e annali di economia” [Economist journal and economy annals], Cedam, Padua.
	163) <i>Striking outlines of De Viti De Marco “First Principles”</i> , in “Rivista internazionale di scienze economiche e commerciali” [International review of economic and commercial sciences], s.l.
	164) <i>Economia della finanza pubblica [Economy of Public finance]</i> , Volume I and II (with Updates), Giuffrè, Milan.
1972	165) <i>Relativizzazione di un teorema [Relativisation of a theorem]</i> , in “Studi in onore di G. U. Papi” [Studies in honour of G.U. Papi], Cedam, Padua.
	166) <i>Nemesi della logica finanziaria (modi e limiti di una tassazione surrogatoria di operazioni bancarie) [Nemesis of financial logic (modes and limits of a surrogate taxation of banking operation)]</i> , in “Rivista Bancaria” [Banking Review], Minerva Bancaria, Milan.
	167) <i>Tendenze economiche in atto e programmi di rilancio dello sviluppo [Economic trends in action and development relaunch programmes]</i> , in “Rivista Bancaria” [Banking Review], Minerva Bancaria, Milan.
	168) <i>Finanza pubblica e benessere in unico modello [Public finance and welfare in a single model]</i> , in “Studi in memoria di Antonio De Viti De Marco” [Studies in memory of Antonio De Viti De Marco], Cacucci, Bari.
1973	1619) <i>Basi reali della cooperazione monetaria [Real bases of monetary cooperation]</i> , in “Giornale degli economisti e annali di economia” [Economist journal and economy annals], Cedam, Padua.
1974	170) <i>Divisione dei poteri e contenzioso tributario [Division of powers and tax litigation]</i> , in “Studi in onore di Giuseppe Chiarelli” [Studies in honour of Giuseppe Chiarelli], s.l.
	171) <i>Nota introduttiva [Introduction note]</i> to the essay of N. Luciani “Le condizioni per l'impiego 'specializzato' delle leve monetaria e fiscale per gli equilibri interno ed esterno” [The conditions for the “specialist” use of monetary and fiscal incentives for internal and external equilibriums], in “Rivista Bancaria” [Banking Review], Minerva Bancaria, Milan.

N.B. The abbreviation “s.l.” means “sine loco”, because of the impossibility of identifying the editor and the place of publication.

* By the nephew Ernesto.