

# 2.5 GHz Wide Band Linear Amplifier with Feedforward Lineariser on a Board

Hiroyuki Kayano, Satoru Iwata\*, Hiroaki Sato\*, and Yuji Iseki

Corporate Research & Development Center, \*Hino Works, Toshiba Corporation  
1, Komukai Toshiba-cho, Saiwai-ku, Kawasaki 212-8582, Japan  
kayano@csl.rdc.toshiba.co.jp

*A wide band feedforward lineariser amplifier we have developed is described. In particular, we report the IM3 improvement obtained without automatic adaptive control circuits, indicating the possibility of realizing small, low-cost products. We designed a lineariser amplifier for 2.5 GHz band to demonstrate the effectiveness of our approach and measurement revealed the wide band linearising capability of over 100 MHz.*

## INTRODUCTION

Mobile radio communication systems and wireless access systems are proliferating and demand for a linear power amplifier offering higher performance is increasing. There are two methods of realizing a linear power amplifier, namely, an amplifier with back-off operation from its 1 dB compression point and an amplifier with added linearised circuits. Linear power amplifiers are required to have high efficiency and low distortion simultaneously. In order to achieve both characteristics, several types of linearised amplifiers have been reported: pre-distortion linearised amplifiers [1-3], feedforward linearised amplifiers [4-6], and adaptive digital linearised amplifiers [7-8]. The feedforward linearised method was reported to offer the greatest improvement in terms of distortion, and can be expected lead to realization of a small, low-cost device. However, this method requires the addition of complicated automatic adaptive control circuits for low distortion characteristic in wide frequency band. A linear amplifier offering great improvement in terms of distortion and that does not require the addition of automatic adaptive control circuits can be expected to be low in cost.

We have developed a 2.5 GHz wide band linear power amplifier with feedforward lineariser on a substrate. Implementation of two delay lines with matching characteristic in wide-band makes it possible to reduce distortion without the addition of automatic adaptive control circuits. The delay lines, which are designed based on electromagnetic analysis, are implemented on the same substrate.

## STRUCTURE OF THE FEEDFORWARD LINEARISER

### Operation of Feedforward Lineariser

A block diagram of a wide-band linear amplifier with a feedforward lineariser is shown in Figure 1. This linearised amplifier has a very simple structure, since it does not require the addition of an automatic adaptive control circuit. The linear amplifier consists of a general amplifier part and a feedforward linearised part. The general amplifier part consists of the power amplifier and the driver amplifier. And the feedforward linearised part consists of circuits whose amplitude and phase are adjusted to reduce distortion.

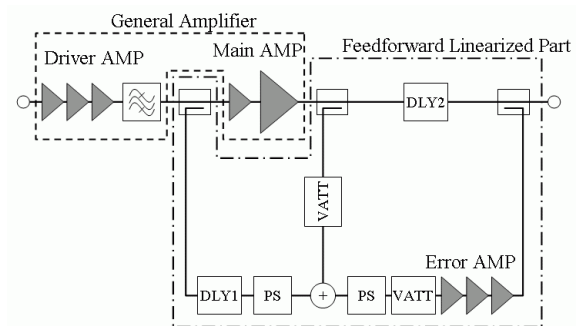

DLY : Delay Line, PS : Phase Shifter, VATT : Variable Attenuator

Figure 1: Block diagram of a linear amplifier with a feedforward lineariser

An operation of the feedforward lineariser, with two-tone spectrum used to illustrate the principle of operation, is shown in Figure 2. The feedforward lineariser consists of a carrier cancellation loop and a distortion cancellation loop. The carrier cancellation loop outputs the distortion signal (spectrum 5) because of the difference between the

power amplifier output signal (spectrum 4) and the original signal (spectrum 3). The distortion cancellation loop outputs the amplified signal (spectrum 6) without the distortion signal because of the difference between the power amplifier output signal (spectrum 2) and the distortion signal (spectrum 5), which is output from the carrier cancellation loop.

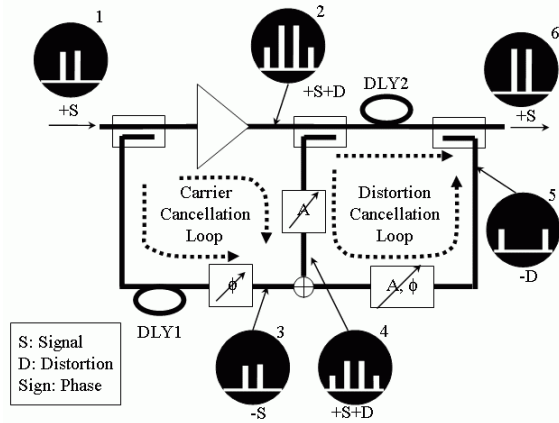

Figure 2: Operation of the feedforward lineariser

### Design of Feedforward Lineariser

A picture of a linear amplifier with feedforward lineariser is shown in Figure 3. A power amplifier, a driver amplifier, an error amplifier, two delay lines, and various adjustable parts for feedforward lineariser are put on a substrate, which is BT resin for low loss and low cost. The size of the substrate is 170x70 mm. The final stage amplifier of the power amplifier, Toshiba's GaAs FET S9G67A, is designed to realize the output back-off margin of 5 dB. A wide band characteristic of the feedforward lineariser depends on frequency characteristics, which are phase and amplitude, of carrier cancellation loop and distortion cancellation loop. Two delay lines (DLY1 and DLY2) with the wide band characteristic are designed based on electromagnetic analysis. The pattern of the delay line is meander microstrip line type. The frequency characteristic of phase depends on the gap of the delay line due to coupling between the microstrip lines. The frequency characteristic of amplitude depends on the return length of the delay line due to self-resonance frequency. In advance, the S parameters for each part of the two cancellation loops were measured. The return length and gap of the delay line were optimized to ensure the frequency characteristic of the delay line was in agreement with the measured S parameters. Also the improvement of IM3 for feedforward circuit greatly depended on an amplitude change due to the simulation. For the improvement of temperature characteristic the linear amplifier used three attenuators with temperature

dependence in the driver amplifier part and two cancellation loops. The developed parameters are shown in Table 1.

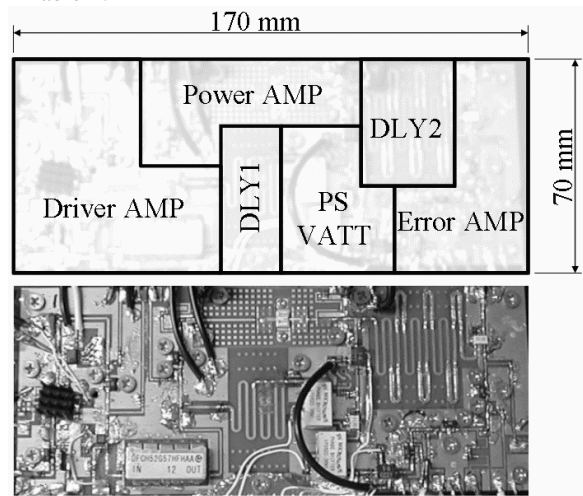

Figure 3: Picture of a linear amplifier with feedforward lineariser

Table 1: Design parameters

Center frequency	2.55 GHz
Bandwidth	>60 MHz
Gain	40 dB
IM3	<-52 dBc
Power consumption	<24 W
Operation voltage	12 V

### MEASUREMENT RESULTS

Measured spectra of this linear amplifier with no operation and operation of the feedforward linearised circuits are shown in Figures 4 and 5, respectively.

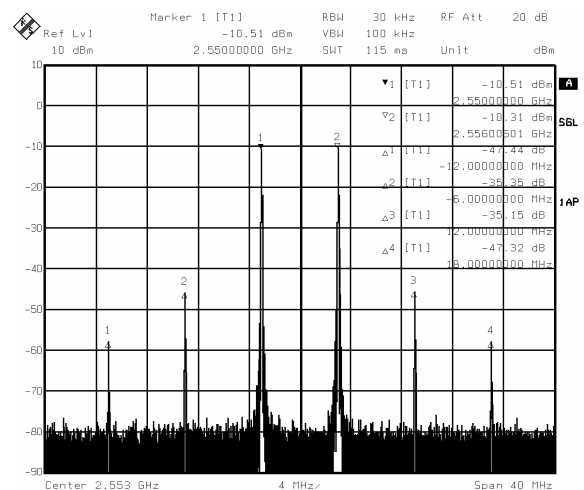

Figure 4: Measured spectrum of the output for the linear amplifier with no operation of the feedforward linearised circuits (spectrum 2)

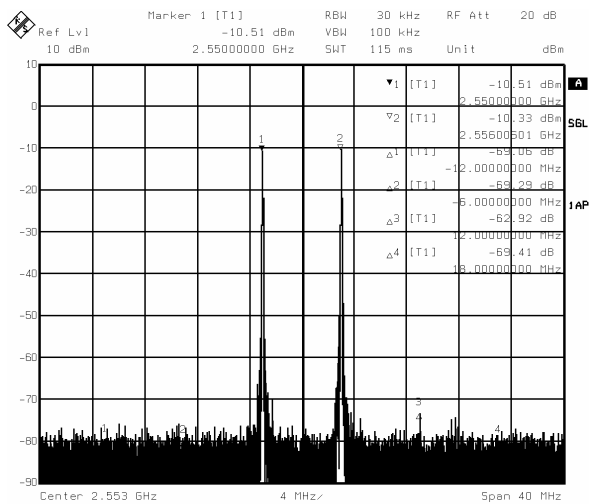

Figure 5: Measured spectrum of the output for the linear amplifier with operation of the feedforward linearised circuits (spectrum 6)

The measured two-tone signal was 2550 MHz and 2556 MHz. The third intermodulation (IM3) of this linear amplifier was improved by over 25 dB. And the fifth intermodulation (IM5) was improved by over 20 dB. Also, the result of QPSK modulated signal was as good as the result of two-tone signal. Measured output power characteristics of IM3 for this linear amplifier are shown in Figure 6 compared with those in the case of no operation of the feedforward linearised circuits. The IM3 characteristics of this linear amplifier were improved by over 25 dB at each output power. Also IM3 value below the output power of 28 dBm could not be measured by the spectrum analyzer.

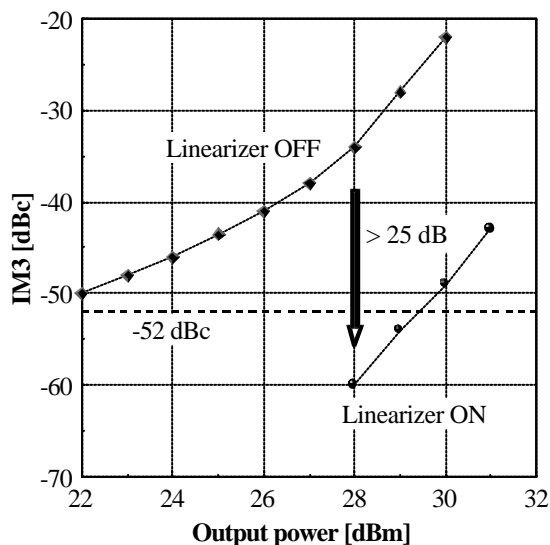

Figure 6: Improvement of IM3 characteristics by feedforward lineariser

Measured temperature characteristics of IM3 for this linear amplifier are shown in Figure 7 compared with the case without attenuator dependent on temperature. Improvement of IM3 between -30 degrees and 60 degrees was over 18 dB, whereas the worst improvement of IM3 without attenuator with temperature dependence was 8 dB. Change of output power between -30 degrees and 60 degrees was 1.0dB or less.

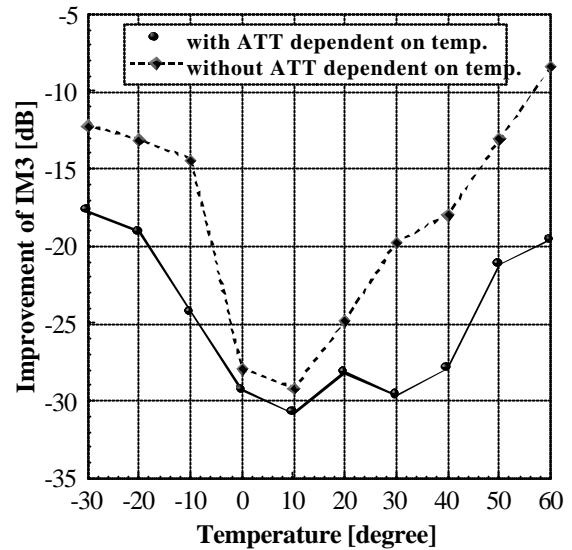

Figure 7: Temperature characteristics of IM3 for feedforward lineariser

Measured frequency characteristic of this linear amplifier is shown in Figure 8. The frequency bandwidth to satisfy the condition of the designed IM3 parameter was 100 MHz without any automatic adaptive control circuits.

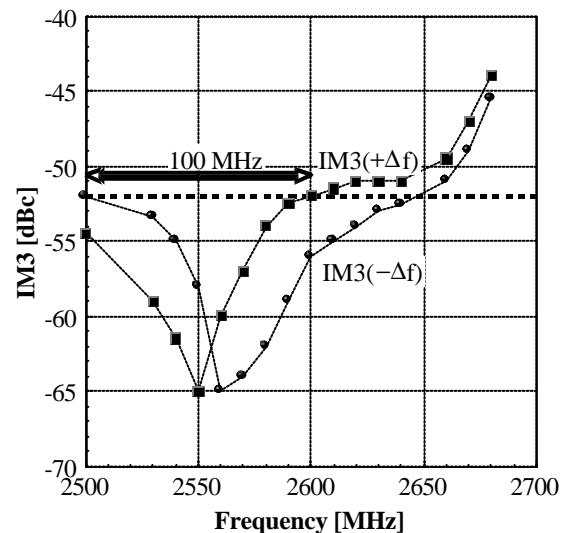

Figure 8: Frequency characteristics of IM3 for feedforward lineariser ( $\Delta f=6$  MHz)

Other measured results, which are center frequency of 2.55 GHz, bandwidth of 100 MHz, Gain of 46 dB, and power consumption of 23.8 W, were obtained. This total power consumption was the sum of consumption of the driver amplifier, the power amplifier, and the error amplifier. When the linearising technique was not applied power consumption of general amplifier with the back-off operation was 31.4 W. The power consumption of final stage amplifier for this linear amplifier was reduced to 38% compared with the back-off operation. Therefore, total power consumption of this linear amplifier was reduced to 75% by the feedforward lineariser technique.

## CONCLUSION

A wide band linear amplifier with feedforward lineariser was developed on a board. This was a linear amplifier without any automatic adaptive control circuits. This approach was adopted in order to realize a small, low-cost linear amplifier. We designed a linear amplifier for 2.5 GHz band to demonstrate the effectiveness of this approach and measurement revealed the wide band linearising capability with bandwidth of 100 MHz. In particular, the very large IM3 improvement of 18 dB at the design frequency of 2550 MHz between -30 degrees and 60 degrees is obtained.

## ACKNOWLEDGEMENT

The authors wish to thank Dr. Keiichi Yamaguchi and Ms. Naoko Ono for their technical contributions.

## REFERENCES

- (1) S. Ogura, K. Seino, T. Ono, A. Kamikokura, and H. Hirose, "Development of a compact, broadband FET linearizer for satellite use," 1997 IEEE MTT-S Int. Microwave Symp. Dig., TH1C-6, pp. 1195-1198, June 1997.
- (2) K. Yamauchi, K. Mori, M. Nakayama, Y. Mitsui, and T. Takagi, "A microwave miniaturized using a parallel diode," 1997 IEEE MTT-S Int. Microwave Symp. Dig., TH1C-7, pp. 1199-1202, June 1997.
- (3) K. Mori, K. Yamauchi, M. Nakayama, Y. Ito, T. Takagi, and H. Kurebayashi, "Improvement of adjacent channel leakage power and intermodulation distortion by using a GaAs FET linearizer with a large source inductance," IEICE Trans. Electron, VOL. E80-C, No. 6, June 1997.
- (4) T. Nojima and S. Narahashi, "Extremely low-distortion multi-carrier amplifier for mobile communication systems – self-adjusting feed-forward amplifier-," IEICE Technical Report, RCS90-4, 1990. (in Japanese)
- (5) E. E. Eid and F. M. Ghannouchi, "Adaptive nulling loop control for 1.7-GHz feedforward linearization systems," IEEE Trans. Microwave Theory and Tech., vol. 45, No. 1, pp. 83-86, Jan. 1997.
- (6) Q. Cheng, C. Yiyuan, and Z. Xiaowei, "1.9 GHz adaptive feedforward power amplifier," 1998 APMC Dig., WEOF01, pp. 745-748, Dec. 1998.
- (7) A. S. Wright and W. G. Durtler, "Experimental performance of an adaptive digital linearized power amplifier," IEEE Trans. On Vehicular Technology, vol. 41, No. 4, pp. 395-400, Nov. 1992.
- (8) P. B. Kenington, M. Cope, R. M. Bennett, and J. Bishop, "A GSM-EDGE high power amplifier utilizing digital linearisation" 2001 IEEE MTT-S Int. Microwave Symp. Dig., TH1D-5, pp. 1517-1520, May 2001.