

Harmonic Reduction Amplifier using $\lambda/4$ High Impedance Bias Line with Defected Ground Structure (DGS)

^o Si-Gyun Jeong^{*}, Do-Kyeong Hwang^{*}, Young-Pil Kwon^{*}, Yong-Chae Jeong^{*}, Chul-Dong Kim^{**}

^{*}Division of Electronics and Information Engineering, Chonbuk Nat'l Univ., Chonju-Si, Korea

^{**} Sewon Teletech, Anyang-Si, Kyounggi-Do, Korea

Email: ycjeong@moak.chonbuk.ac.kr

Abstract – In this paper, a new defected ground structure (DGS) $\lambda/4$ bias line that dumbbell-shaped ground pattern is etched on ground plane of microstrip line is proposed. This DGS $\lambda/4$ bias line maintains high impedance, but physical width is wider and length is shorter than that of the conventional bias line. If the proposed bias line is attached on signal transmission line, this bias line can reduce the 3rd harmonic signal as well as the 2nd harmonic signal. With harmonic reduction characteristics, efficiency and linearity of amplifier are improved. When the proposed bias line is adopted in power amplifier on IMT-2000 basestation transmitting band, the 3rd harmonic signal is reduced about 26.5dB and efficiency is improved about 9.1% and IMD₃ is improved 4.5dB than the conventional structure.

INTRODUCTION

Microwave amplifier is a device to amplify signal on microwave band. Which uses DC bias power as signal amplifying energy and isolation between bias circuit and signal path is very important. Small signal amplifier in UHF band usually uses chip inductor as RF choke in signal transmission line. And also $\lambda/4$ transmission line that is terminated with chip capacitor or radial stub is used as bias line (1). To minimize interference of bias line at signal transmission line, it is good choice that the difference of characteristic impedance between bias line and signal transmission line makes as high as possible. So high impedance $\lambda/4$ bias line is generally used. But in case of high power amplifier, transistor consumes much current, so the width of $\lambda/4$ -bias line must be much wider than that of small signal transistor to minimize voltage drop in bias line. That means to reduce characteristic impedance value. So isolation between bias circuit and signal path in high power amplifier is more difficult than small signal amplifier and there is much more possibility to oscillate. And when capacitive-terminated $\lambda/4$ bias line is connected at signal path, even harmonic frequency components of $1/\lambda$ in signal path are blocked but odd harmonic frequency components are passed away.

In this paper, a new defected ground structure (DGS) $\lambda/4$ bias line that dumbbell-shaped ground pattern is etched on ground plane of microstrip line is proposed. This bias line maintains high characteristic impedance value, but width is much wider and length is shorter slightly than the conventional $\lambda/4$ bias microstrip line. When the

proposed bias line is used in amplifier design, the 3rd harmonic signal as well as the 2nd harmonic signal on signal path can be reduced.

$\lambda/4$ High Impedance Bias Transmission Line Design Using Defected Ground Structure (DGS)

Etching of dumbbell-shaped ground pattern that located just below microstrip line is equivalent to increasing of serial inductance of transmission line impedance (2)~(3). For defected ground microstrip line maintains the specific characteristic impedance of the conventional microstrip line, width of microstrip line must be wider. That is equivalent to increasing of shunt capacitance of transmission line impedance. Increasing of the equivalent series inductance and shunt capacitance induces increasing of phase constant and slow-wave effect. So defected ground structure of transmission line can make circuit downsizing. Figure 1 show layout of DGS microstrip line that is connected 50 Ω microstrip line, simulation results of transfer characteristics and slow-wave factor. Where characteristic impedance of DGS microstrip line is also 50 Ω under 3.5GHz. This circuit is simulated with Ansoft HFSS V. 6.0. The used PCB is RT/duroid-5880 of Rogers with dielectric constant (ϵ_r) of 2.2, and height (h) of 31mil, and copper thickness (t) of 1Oz. And cell parameters of DGS pattern are a=6mm, b=1mm, and g=0.5mm. Width of DGS transmission line (c) is 4.76mm that is much wider than width of the conventional 50 Ω microstrip line (w=2.38 mm). The measurement result shows that there is no problem in signal transmission and slow-wave effect is perceptible as frequency increases.

Slow-wave effect of DGS microstrip line according to operating frequency can be applied to capacitive-terminated $\lambda/4$ bias line of power amplifier. If DGS $\lambda/4$ bias microstrip line can support high impedance value, wider width, and shorter length than conventional bias line and reject the 2nd and 3rd harmonic signals, power amplifier would be more stable and efficient. Figure 2 shows layout of DGS $\lambda/4$ bias microstrip line connected on 50 Ω signal line. Where cell parameters of DGS pattern are a=6mm, b=3mm, g=0.5mm, width of DGS line (c) is 1.23mm. The characteristic impedance of DGS $\lambda/4$ bias microstrip line is 120 Ω and $\lambda/4$ length at operating frequency 2.14GHz is 23.8mm. But in the case of the conventional $\lambda/4$ bias line, width is 0.41mm and length is 25.1mm. So width is enlarged 3 times and length is shorter slightly. Figure 3 shows the simulated and test results of the conventional $\lambda/4$ bias microstrip line that is connected signal line. Also Figure 4 shows the simulated and test results of DGS $\lambda/4$ bias microstrip line. The simulated and test results show similar characteristics on the dominant frequency and the 2nd harmonic frequency. But the 3rd harmonic frequency characteristic is much different. Whereas the 3rd harmonic frequency component of conventional $\lambda/4$ bias line is passed away, the 3rd harmonic frequency component of DGS $\lambda/4$ bias line can't be passed away.

AMPLIFIER DESIGN & TEST RESULTS

To show validation of DGS $\lambda/4$ bias transmission line, power amplifier that can be operated in IMT-2000 basestation transmitter is fabricated. Operating frequency is 2.11~2.17GHz and the used transistor is FLL357ME of Fujitsu. When the conventional $\lambda/4$ bias microstrip line is adopted, gain of fabricated amplifier is 12.8 \pm 0.1dB and return loss is less than -21.8dB and 1dB compression point (P_{1dB}) is 35.33dBm. Figure 5 shows transfer and reflective characteristics. And also shows frequency spectrum at 35dBm, that input signal is CW signal. Harmonic characteristics show that the signal difference between the dominant and the 2nd harmonic is 39.21dBc and between the dominant and the 3rd harmonic is 29.55dBc.

Figure 6 shows transfer and reflective characteristics of DGS $\lambda/4$ bias transmission line. And also shows frequency spectrum at 35dBm. The gain of fabricated amplifier is 13.35 \pm 0.07dB and return loss is less than -21.2dB and 1dB compression point (P_{1dB}) is 35.78dBm. The transfer and reflective characteristics are very similar those of the conventional bias line. Harmonic characteristics show that the signal difference between the dominant and the 2nd harmonic is 40.07dBc and between the dominant and the 3rd harmonic is 56.06dBc. By comparing the amplifier using the conventional $\lambda/4$ bias line with the amplifier using DGS $\lambda/4$ bias line, the

3rd harmonic signal level can be reduced about 26.51dB. Figure 7 shows photographs of the fabricated amplifier with DGS $\lambda/4$ bias line. Also figure 8 shows comparison results of the 3rd harmonic signal level between the fabricated amplifier and the conventional amplifier according to change of frequency. The 3rd harmonic signal reduction characteristics is very similar to harmonic signal reduction characteristics of DGS $\lambda/4$ bias microstrip line.

Figure 9 shows comparison results of amplifier efficiency according to change input power level. With DGS $\lambda/4$ bias transmission line, the measurement shows an increase of 0.5~9.14% in PAE. Figure 10 shows measured IMD3 and IMD5 results. When output power level is 29dBm/tone, IMD₃ and IMD₅ is improved 4.4dBc and 4.5dBc, respectively.

CONCLUSION

In this paper, a new defected ground structure (DGS) $\lambda/4$ bias line that dumbbell-shaped ground pattern is etched on ground plane of microstrip line is proposed. This DGS $\lambda/4$ bias microstrip line maintains high impedance and offers wider width and shorter length. Also offers signal rejection characteristic of the 3rd harmonic signal as well as 2nd harmonic signal. When this DGS $\lambda/4$ bias line is adopted in power amplifier that can be operated in IMT-2000 basestation transmitter, transfer characteristics are similar those of the conventional $\lambda/4$ bias line in operating band and the 2nd harmonic band. But the 3rd harmonics signal level of power amplifier using DGS bias line is reduced more than 15dB in overall band. Also P_{1dB} is increased about 0.45dB and PAE is improved about 0.5~9.1%. IMD₃ and IMD₅ are improved 4.5dB. We think that this bias line can be used other microwave circuit applications.

ACKNOWLEDGEMENT

This work was supported by grant No. 2000-1-30200-007-3 from the Basic Research Program of the Korea Science & Engineering Foundation.

REFERENCES

- (1) Guillermo Gonzalez, "Microwave Transistor Amplifiers (Prentice Hall, 1997), pp.273-283
- (2) C. S. Kim, J. S. Park, D. Ahn, J. B. Lim, "A Novel 1 D Periodic Defected Ground Structure for Planar Circuits," *IEEE Microwave and Guided Wave Letters*, Vol. 10, No. 4, pp.131-133, Apr. 2000.
- (3) C. S. Kim, J. S. Lim, J. S. Park, D. Ahn, S. W. Nam, "A 10dB Branch Line Coupler Using Defected Ground Structure," *European Microwave Conference Digest*, pp.68-71, 2000.

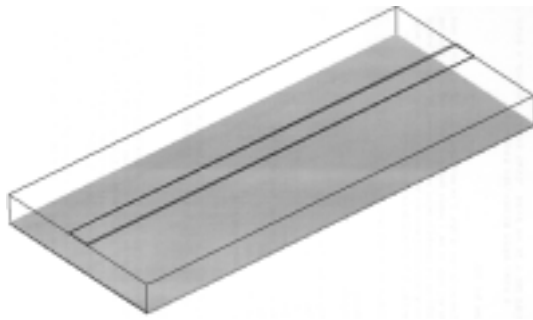

(a)

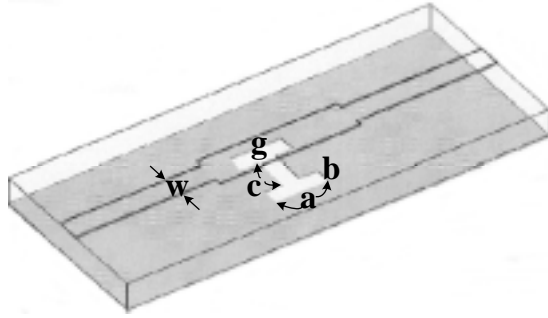

(b)

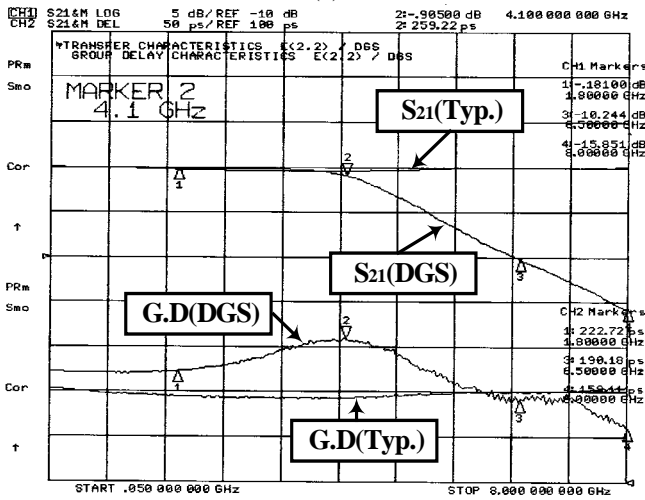

(c)

Fig. 1 (a) Schematic of microstrip line
 (b) Schematic of DGS microstrip line
 (c) Comparison of transfer and group delay characteristics

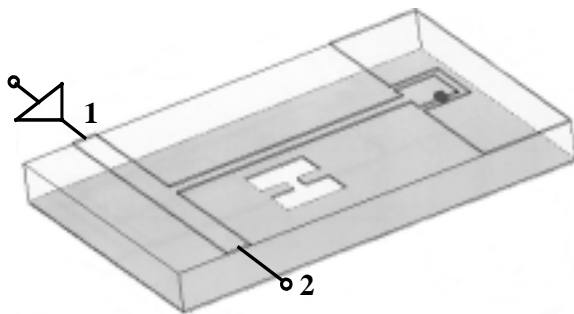
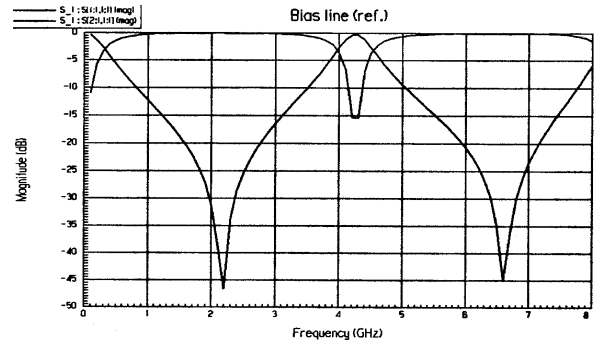
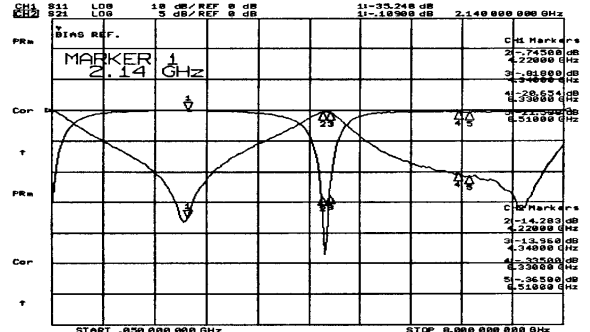

Fig. 2 Layout of DGS $\lambda/4$ bias transmission line



(a)



(b)

Fig. 3 (a) Simulation result of the conventional $\lambda/4$ bias transmission line
 (b) Test result of the conventional $\lambda/4$ bias transmission line

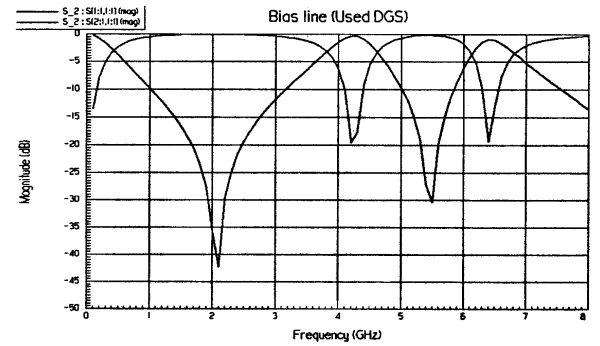

(a)

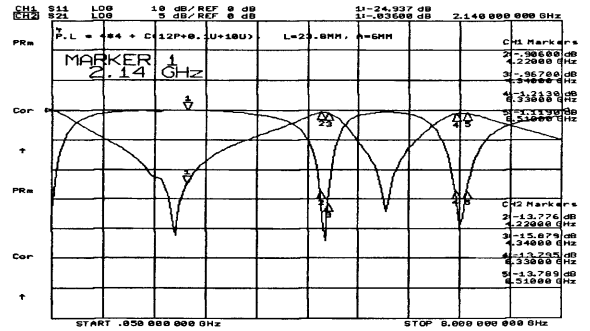

(b)

Fig. 4 (a) Simulation result of DGS $\lambda/4$ bias transmission line
 (b) Test result of DGS $\lambda/4$ bias transmission line

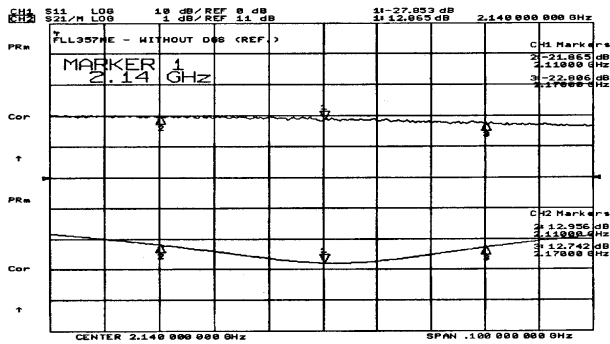

(a)

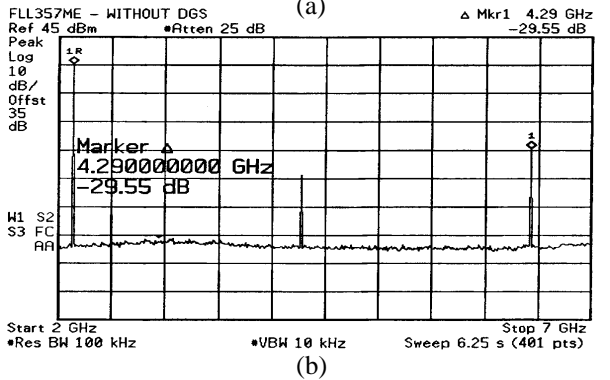

(b)

Fig. 5 The fabricated amplifier characteristics using the conventional $\lambda/4$ bias transmission line

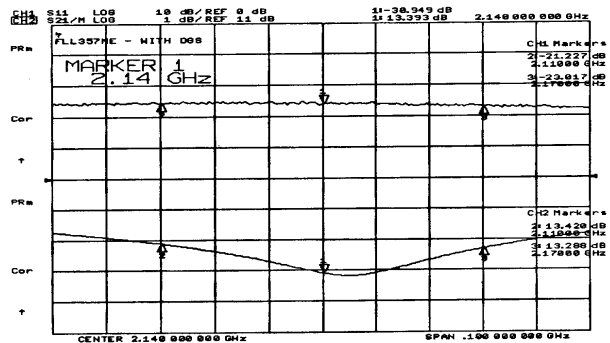
(a) S_{21} , S_{11} (b) Harmonic characteristics (@ $P_o=35$ dBm)

(a)

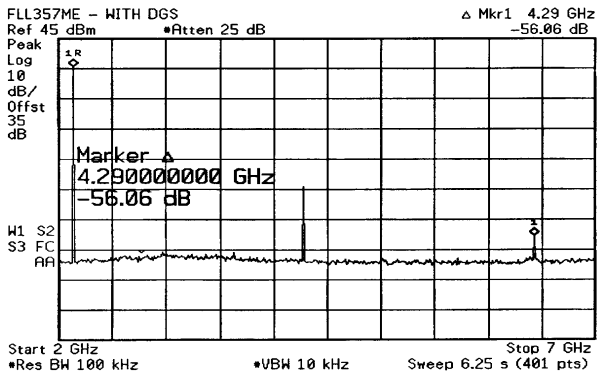

(b)

Fig. 6 The fabricated amplifier characteristics using the DGS $\lambda/4$ bias transmission line

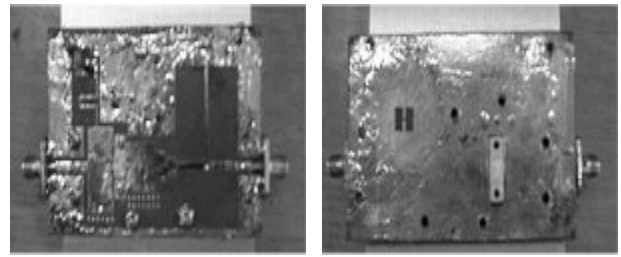
(a) S_{21} , S_{11} (b) Harmonic characteristics (@ $P_o=35$ dBm)

(a)

(b)

Fig. 7 Photographs of the fabricated amplifier with DGS $\lambda/4$ bias transmission line

(a) Top view

(b) Bottom view

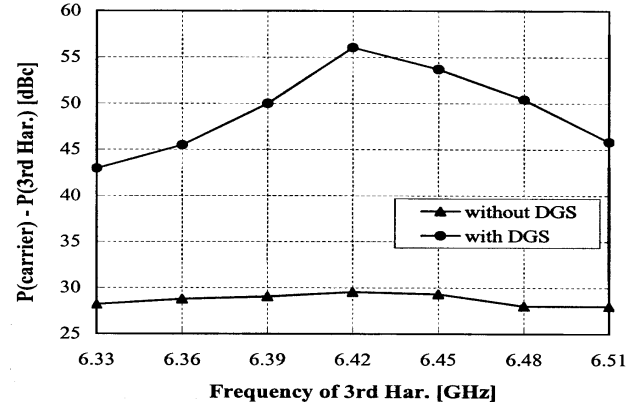

Fig. 8 The 3rd harmonic signal level comparison between the fabricated amplifier and the conventional amplifier

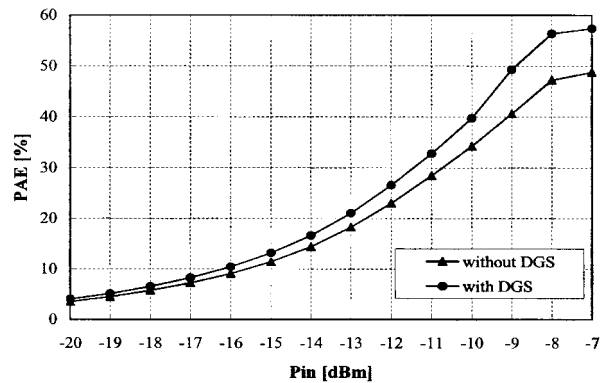

Fig. 9 PAE comparison due to input power level

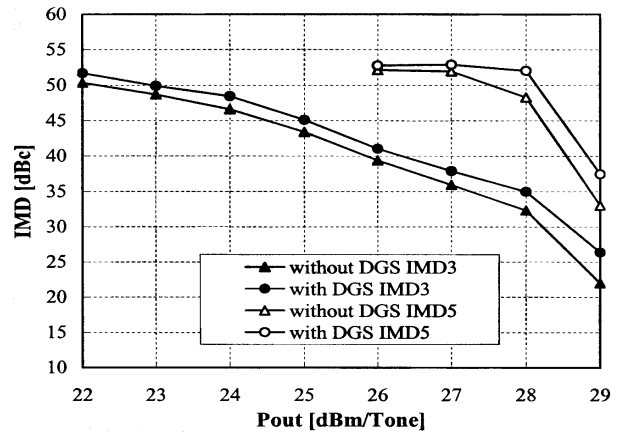

Fig. 10 Comparison of the 3rd and 5th intermodulation distortion characteristics